

## HOW TO USE THIS MANUAL

This service manual describes the service procedures for the VTX1800R.

Follow the Maintenance Schedule (Section 3) recommendations to ensure that the vehicle is in peak operating condition and the emission levels are within the standards set by the U.S. Environmental Protection Agency, California Air Resources Board (CARB) and Transport Canada.

Performing the first scheduled maintenance is very important. It compensates for the initial wear that occurs during the break-in period.

Sections 1 and 3 apply to the whole motorcycle. Section 2 illustrates procedures for removal/installation of components that may be required to perform service described in the following sections.

Sections 4 through 20 describe parts of the motorcycle, grouped according to location.

Find the section you want on this page, then turn to the table of contents on the first page of the section.

Most sections start with an assembly or system illustration, service information and troubleshooting for the section. The subsequent pages give detailed procedures.



If you don't know the source of the trouble, go to section 21 Troubleshooting.

Your safety, and the safety of others, is very important. To help you make informed decisions we have provided safety messages and other information throughout this manual. Of course, it is not practical or possible to warn you about all the hazards associated with servicing this vehicle. You must use your own good judgement.

You will find important safety information in a variety of forms including:

- Safety Labels – on the vehicle
- Safety Messages – preceded by a safety alert symbol  and one of three signal words, DANGER, WARNING, or CAUTION.

These signal words mean:

-  **DANGER** You WILL be KILLED or SERIOUSLY HURT if you don't follow instructions.
-  **WARNING** You CAN be KILLED or SERIOUSLY HURT if you don't follow instructions.
-  **CAUTION** You CAN be HURT if you don't follow instructions.

- Instructions – how to service this vehicle correctly and safely.

As you read this manual, you will find information that is preceded by a  symbol. The purpose of this message is to help prevent damage to your vehicle, other property, or the environment.

**ALL INFORMATION, ILLUSTRATIONS, DIRECTIONS AND SPECIFICATIONS INCLUDED IN THIS PUBLICATION ARE BASED ON THE LATEST PRODUCT INFORMATION AVAILABLE AT THE TIME OF APPROVAL FOR PRINTING. HONDA MOTOR CO., LTD. RESERVES THE RIGHT TO MAKE CHANGES AT ANY TIME WITHOUT NOTICE AND WITHOUT INCURRING ANY OBLIGATION WHATSOEVER. NO PART OF THIS PUBLICATION MAY BE REPRODUCED WITHOUT WRITTEN PERMISSION. THIS MANUAL IS WRITTEN FOR PERSONS WHO HAVE ACQUIRED BASIC KNOWLEDGE OF MAINTENANCE ON HONDA MOTORCYCLES, MOTOR SCOOTERS OR ATVS.**

HONDA MOTOR CO., LTD.  
SERVICE PUBLICATION OFFICE

## CONTENTS

	<b>GENERAL INFORMATION</b>	<b>1</b>
	<b>FRAME/BODY PANELS/EXHAUST SYSTEM</b>	<b>2</b>
	<b>MAINTENANCE</b>	<b>3</b>
<b>ENGINE AND DRIVE TRAIN</b>	<b>LUBRICATION SYSTEM</b>	<b>4</b>
	<b>FUEL SYSTEM (Programmed Fuel Injection)</b>	<b>5</b>
	<b>COOLING SYSTEM</b>	<b>6</b>
	<b>ENGINE REMOVAL/INSTALLATION</b>	<b>7</b>
	<b>CYLINDER HEAD/VALVES</b>	<b>8</b>
	<b>CYLINDER/PISTON</b>	<b>9</b>
	<b>CLUTCH/GEARSHIFT LINKAGE</b>	<b>10</b>
	<b>CRANKSHAFT/TRANSMISSION</b>	<b>11</b>
	<b>FINAL DRIVE</b>	<b>12</b>
	<b>CHASSIS</b>	<b>FRONT WHEEL/SUSPENSION/STEERING</b>
<b>REAR WHEEL/SUSPENSION</b>		<b>14</b>
<b>HYDRAULIC BRAKE</b>		<b>15</b>
<b>ELECTRICAL</b>	<b>CHARGING SYSTEM/ALTERNATOR</b>	<b>16</b>
	<b>IGNITION SYSTEM</b>	<b>17</b>
	<b>ELECTRIC STARTER/STARTER CLUTCH</b>	<b>18</b>
	<b>LIGHTS/METERS/SWITCHES</b>	<b>19</b>
	<b>WIRING DIAGRAM</b>	<b>20</b>
	<b>TROUBLESHOOTING</b>	<b>21</b>
	<b>INDEX</b>	<b>22</b>

# 1. GENERAL INFORMATION

1

<b>SERVICE RULES</b>	<b>1-1</b>	<b>LUBRICATION &amp; SEAL POINTS</b>	<b>1-19</b>
<b>MODEL IDENTIFICATION</b>	<b>1-1</b>	<b>CABLE &amp; HARNESS ROUTING</b>	<b>1-23</b>
<b>SPECIFICATIONS</b>	<b>1-3</b>	<b>EMISSION CONTROL SYSTEMS</b>	<b>1-33</b>
<b>TORQUE VALUES</b>	<b>1-12</b>	<b>EMISSION CONTROL INFORMATION LABELS (U.S.A. ONLY)</b>	<b>1-36</b>
<b>TOOLS</b>	<b>1-17</b>		

## SERVICE RULES

1. Use genuine HONDA or HONDA-recommended parts and lubricants or their equivalents. Parts that do not meet HONDA's design specifications may cause damage to the motorcycle.
2. Use the special tools designed for this product to avoid damage and incorrect assembly.
3. Use only metric tools when servicing the motorcycle. Metric bolts, nuts and screws are not interchangeable with English fasteners.
4. Install new gaskets, O-rings, cotter pins, and lock plates when reassembling.
5. When tightening bolts or nuts, begin with the larger diameter or inner bolt first. Then tighten to the specified torque diagonally in incremental steps unless a particular sequence is specified.
6. Clean parts in cleaning solvent upon disassembly. Lubricate any sliding surfaces before reassembly.
7. After reassembly, check all parts for proper installation and operation.
8. Route all electrical wires as shown on pages 1-23 through 1-32, Cable and Harness Routing.

## MODEL IDENTIFICATION

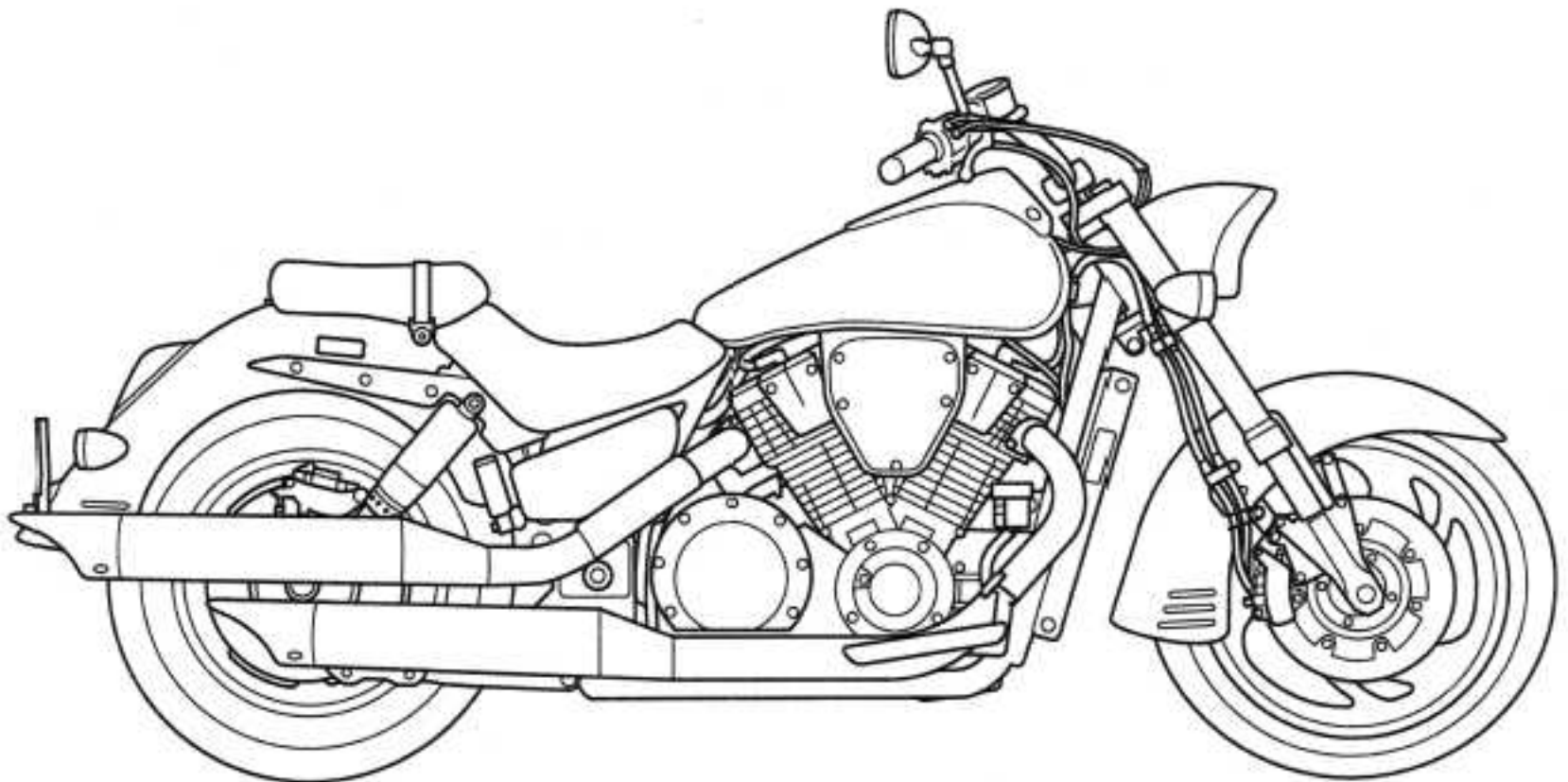

## GENERAL INFORMATION

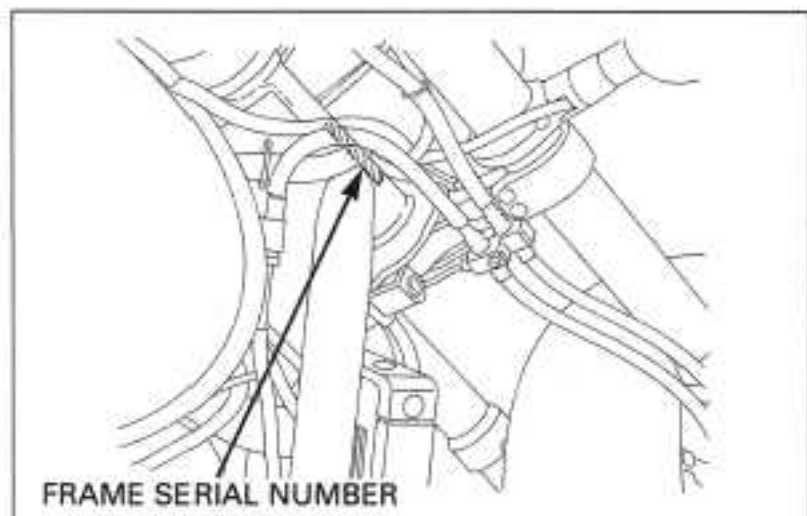

- (1) The frame serial number is stamped on the right side of the steering head.

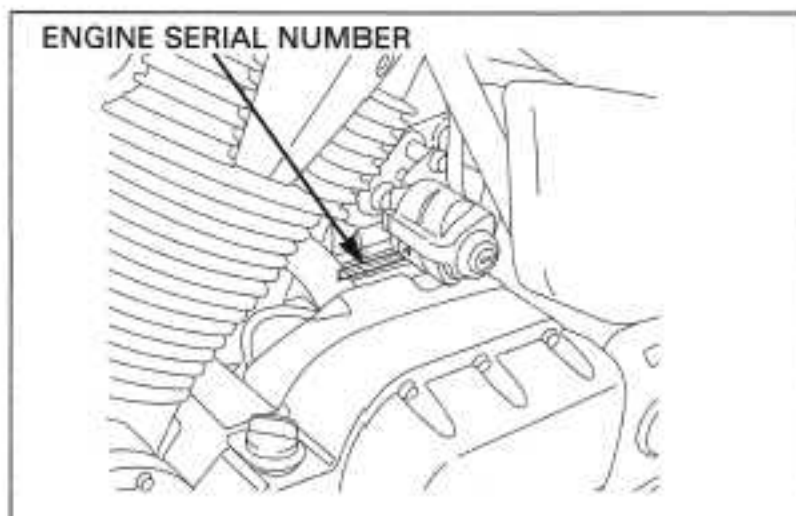

- (2) The engine serial number is stamped on the right side of the upper crankcase.

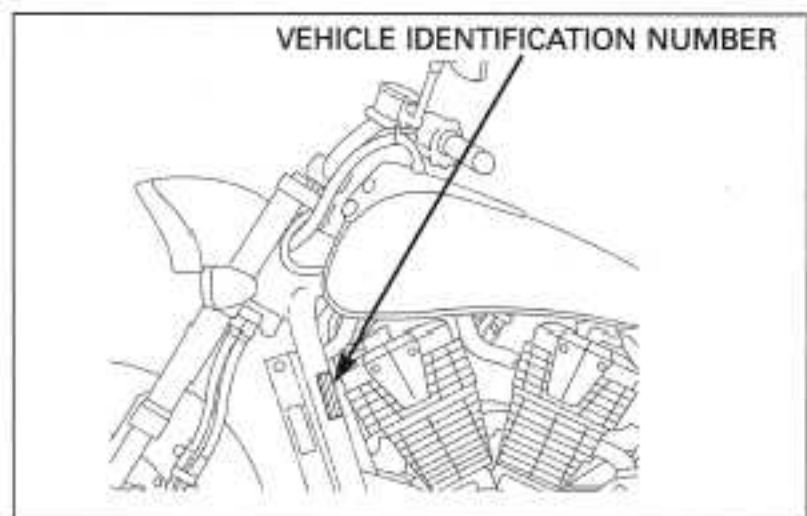

- (3) The Vehicle Identification Number (VIN) is located on left side of the main frame on the Safety Certification Labels.



- (4) The throttle body identification number is stamped on the intake side of the throttle body as shown.

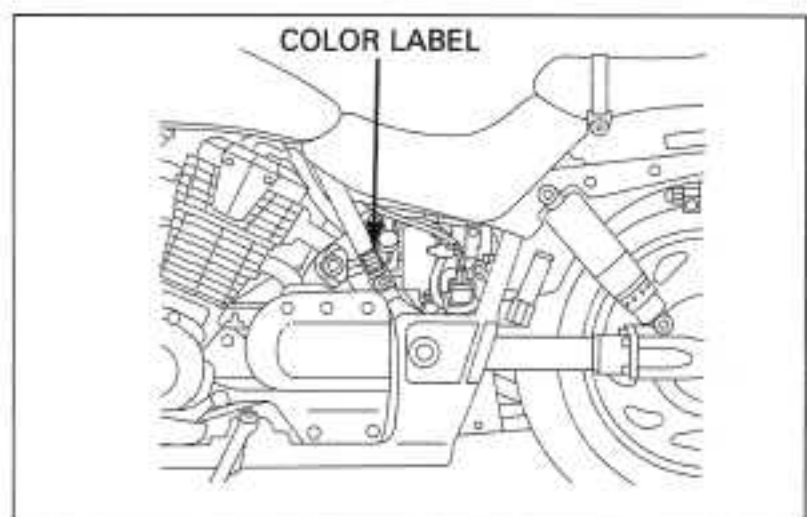

- (5) The color label is attached as shown. When ordering color-coded parts, always specify the designated color code.

**SPECIFICATIONS**

GENERAL		
	ITEM	SPECIFICATIONS
DIMENSIONS	Overall length Overall width Overall height Wheelbase Seat height Footpeg height Ground clearance Dry weight     49 state/Canada type California type Curb weight     49 state/Canada type California type Maximum weight capacity 49 state/California type Canada type	2,630 mm (103.5 in) 990 mm (39.0 in) 1,155 mm (45.5 in) 1,715 mm (67.5 in) 695 mm (27.4 in) 278 mm (10.9 in) 140 mm (5.5 in) 336 kg (741 lbs) 337 kg (743 lbs) 359 kg (791 lbs) 360 kg (794 lbs) 186 kg (410 lbs) 190 kg (419 lbs)
FRAME	Frame type Front suspension Front axle travel Rear suspension Rear axle travel Front tire size Rear tire size Front tire brand Rear tire brand Front brake Rear brake Caster angle Trail length Fuel tank capacity	Double cradle Telescopic fork 130 mm (5.1 in) Swingarm 100 mm (3.9 in) 150/80R17M/C 72H 180/70R16M/C 77H (Dunlop) D251F (Dunlop) D251 Hydraulic double disc Hydraulic single disc 32° 163 mm (6.4 in) 20.0 liter (5.28 US gal, 4.40 Imp gal)
ENGINE	Cylinder arrangement Bore and stroke Displacement Compression ratio Valve train Intake valve    opens ———— closes ———— Exhaust valve opens ———— closes ———— Lubrication system Oil pump type Cooling system Air filtration Engine dry weight Firing order Cylinder number	2 cylinders 52° V transverse 101.0 x 112.0 mm (3.98 x 4.41 in) 1,795 cm <sup>3</sup> (109.5 cu-in) 9.0 : 1 Chain driven, OHC 8° BTDC 52° ABDC 48° BBDC 12° ATDC Forced pressure and dry sump Trochoid Liquid cooled Paper element 122.5 kg (270 lbs) Front – 232° – Rear – 488° – Front – Front: #2, Rear: #1



## GENERAL INFORMATION

GENERAL (cont'd)		
	ITEM	SPECIFICATIONS
CARBURETION	Type Throttle bore	PGM-FI (Programmed Fuel Injection) 42 mm (1.7 in)
DRIVE TRAIN	Clutch system Clutch operation system Transmission Primary reduction Secondary reduction (Output drive reduction) Final reduction Gear ratio                   1st 2nd 3rd 4th 5th Gearshift pattern	Multi-plate, wet Hydraulic operating Constant mesh, 5-speeds 1.571 (55/35) 0.944 (17/18) 3.091 (34/11) 2.353 (40/17) 1.478 (34/23) 1.111 (30/27) 0.871 (27/31) 0.697 (23/33) Left foot operated return system, 1 - N - 2 - 3 - 4 - 5
ELECTRICAL	Ignition system Starting system Charging system Regulator/rectifier Lighting system	Computer-controlled digital transistorized with electric advance Electric starter motor Triple phase output alternator SCR shorted/triple phase, full wave rectification Battery

## GENERAL INFORMATION

Unit: mm (in)

<b>LUBRICATION SYSTEM</b>				
ITEM			STANDARD	SERVICE LIMIT
Engine oil capacity	After draining		3.5 liter (3.7 US qt, 3.1 Imp qt)	—
	After draining/filter change		3.7 liter (3.9 US qt, 3.3 Imp qt)	—
	After disassembly		4.5 liter (4.8 US qt, 4.0 Imp qt)	—
Recommended engine oil			Pro HONDA GN4 or HP4 4-stroke oil (U.S.A. and Canada) or Honda 4-stroke oil (Canada only), or equivalent motor oil API service classification SF or SG Viscosity: SAE 10W-40	—
Oil pressure at oil pressure switch			530 kPa (5.4 kgf/cm <sup>2</sup> , 77 psi) at 5,000 rpm/(80°C/176°F)	—
Oil pump rotor	Feed pump	Tip clearance	0.15 (0.006)	0.20 (0.008)
		Body clearance	0.15 – 0.21 (0.006 – 0.008)	0.35 (0.014)
		Side clearance	0.02 – 0.07 (0.001 – 0.003)	0.10 (0.004)
	Scavenge pump	Tip clearance	0.15 (0.006)	0.20 (0.008)
		Body clearance	0.15 – 0.21 (0.006 – 0.008)	0.35 (0.014)
		Side clearance	0.02 – 0.07 (0.001 – 0.003)	0.10 (0.004)

### FUEL SYSTEM (Programmed Fuel Injection)

ITEM	SPECIFICATIONS
Throttle body identification number	GQ42A
Idle speed	800 ± 100 rpm
Throttle grip free play	2 – 6 mm (1/16 – 1/4 in)
Intake air temperature sensor resistance (at 20°C/68°F)	1 – 4 kΩ
Engine coolant temperature sensor resistance (at 20°C/68°F)	2.3 – 2.6 kΩ
Fuel injector resistance (at 20°C/68°F)	13.4 – 14.2 Ω
PAIR solenoid valve resistance (at 20°C/68°F)	20 – 24 Ω
Cam pulse generator peak voltage (at 20°C/68°F)	0.7 V minimum
Ignition pulse generator peak voltage (at 20°C/68°F)	0.7 V minimum
Manifold absolute pressure at idle	290 mm Hg
Fuel pressure at idle	343 kPa (3.5 kgf/cm <sup>2</sup> , 50 psi)
Fuel pump flow (at 12 V)	188 cm <sup>3</sup> (6.4 US oz, 6.6 Imp oz) minimum/10 seconds

### COOLING SYSTEM

ITEM	SPECIFICATIONS	
Coolant capacity	Radiator and engine	2.60 liter (2.75 US qt, 2.29 Imp qt)
	Reserve tank	0.46 liter (0.49 US qt, 0.40 Imp qt)
Radiator cap relief pressure	108 – 137 kPa (1.1 – 1.4 kgf/cm <sup>2</sup> , 16 – 20 psi)	
Thermostat	Begin to open	80 – 84 °C (176 – 183 °F)
	Fully open	95 °C (203 °F)
	Valve lift	8 mm (0.3 in) minimum
Recommended antifreeze	Pro Honda HP coolant or equivalent high quality ethylene glycol antifreeze containing silicate-free corrosion inhibitors	
Standard coolant concentration	1:1 mixture with soft water	

## GENERAL INFORMATION

CYLINDER HEAD/VALVES			Unit: mm (in)	
ITEM			STANDARD	SERVICE LIMIT
Cylinder compression			657 kPa (6.7 kgf/cm <sup>2</sup> , 95 psi) at 320 rpm	—
Valve clearance		IN	0.13 ± 0.02 (0.005 ± 0.001)	—
		EX	0.32 ± 0.02 (0.013 ± 0.001)	—
Camshaft	Cam lobe height	IN	39.953 – 40.033 (1.5729 – 1.5761)	39.92 (1.572)
		EX	39.423 – 39.503 (1.5521 – 1.5552)	39.40 (1.551)
	Runout		—	0.05 (0.002)
Oil clearance			0.040 – 0.101 (0.0016 – 0.0040)	0.12 (0.005)
Rocker arm, rocker arm shaft	Rocker arm shaft O.D.	IN/EX	13.976 – 13.994 (0.5502 – 0.5509)	13.92 (0.548)
	Rocker arm I.D.	IN/EX	14.006 – 14.024 (0.5514 – 0.5521)	14.05 (0.553)
	Rocker arm-to-rocker arm shaft clearance		0.012 – 0.048 (0.0005 – 0.0019)	0.14 (0.006)
Valve, valve guide	Valve stem O.D.	IN	6.575 – 6.590 (0.2589 – 0.2594)	6.57 (0.259)
		EX	7.955 – 7.970 (0.3132 – 0.3138)	7.94 (0.313)
	Valve guide I.D.	IN	6.600 – 6.615 (0.2598 – 0.2604)	6.635 (0.2612)
		EX	8.000 – 8.015 (0.3150 – 0.3156)	8.055 (0.3171)
	Stem-to-guide clearance	IN	0.010 – 0.040 (0.0039 – 0.0016)	0.08 (0.003)
		EX	0.030 – 0.060 (0.0012 – 0.0024)	0.12 (0.005)
	Valve guide projection above cylinder head	IN	16.4 – 16.6 (0.646 – 0.654)	—
		EX	17.7 – 17.9 (0.697 – 0.705)	—
Valve seat width	IN	1.10 – 1.30 (0.043 – 0.051)	1.70 (0.669)	
	EX	1.40 – 1.60 (0.055 – 0.063)	2.00 (0.079)	
Valve spring free length		IN	43.5 (1.71)	41.9 (1.65)
		EX	44.2 (1.74)	42.4 (1.67)
Cylinder head warpage			—	0.10 (0.004)

## GENERAL INFORMATION

Unit: mm (in)

<b>CYLINDER/PISTON</b>		<b>ITEM</b>	<b>STANDARD</b>	<b>SERVICE LIMIT</b>
Piston, piston rings	Piston O.D. at 18mm (0.7in) from bottom		100.97 – 100.99 (3.9752 – 3.9760)	100.91 (3.973)
	Piston pin bore I.D.		24.002 – 24.008 (0.9450 – 0.9452)	24.018 (0.9456)
	Piston pin O.D.		23.994 – 24.000 (0.9446 – 0.9449)	23.984 (0.9443)
	Piston-to-piston pin clearance		0.002 – 0.014 (0.0001 – 0.0006)	0.034 (0.0013)
	Piston ring end gap	Top	0.25 – 0.40 (0.010 – 0.016)	0.55 (0.022)
		Second	0.40 – 0.55 (0.016 – 0.022)	0.70 (0.028)
		Oil (side rail)	0.20 – 0.70 (0.008 – 0.028)	0.90 (0.035)
	Piston ring-to-ring groove clearance	Top	0.015 – 0.050 (0.0006 – 0.0020)	0.07 (0.003)
Second		0.015 – 0.050 (0.0006 – 0.0020)	0.07 (0.003)	
Cylinder	I.D.		101.000 – 101.015 (3.9763 – 3.9770)	101.05 (3.978)
	Out-of-round		—	0.10 (0.004)
	Taper		—	0.10 (0.004)
	Warpage		—	0.10 (0.004)
Cylinder-to-piston clearance		0.01 – 0.045 (0.0004 – 0.0018)	0.32 (0.126)	
Connecting rod small end I.D.		24.020 – 24.041 (0.9457 – 0.9465)	24.051 (0.9469)	
Connecting rod-to-piston pin clearance		0.020 – 0.047 (0.0008 – 0.0019)	0.07 (0.003)	

Unit: mm (in)

<b>CLUTCH/GEARSHIFT LINKAGE</b>		<b>ITEM</b>	<b>STANDARD</b>	<b>SERVICE LIMIT</b>
Recommended clutch fluid		DOT 4 brake fluid		—
Clutch master cylinder	Cylinder I.D.	12.700 – 12.743 (0.5000 – 0.5017)	12.76 (0.502)	
	Piston O.D.	12.657 – 12.684 (0.4983 – 0.4994)	12.65 (0.498)	
Clutch	Spring free length	58.2 (2.29)	56.7 (2.23)	
	Disc thickness	3.72 – 3.88 (0.146 – 0.153)	3.1 (0.12)	
	Plate warpage	—	0.30 (0.012)	
Clutch outer guide I.D.		27.995 – 28.012 (1.1022 – 1.1028)	28.8 (1.106)	
Mainshaft O.D. at clutch outer guide		27.980 – 27.993 (1.1016 – 1.1021)	27.970 (1.1012)	

Unit: mm (in)

<b>ALTERNATOR/STARTER CLUTCH</b>		<b>ITEM</b>	<b>STANDARD</b>	<b>SERVICE LIMIT</b>
Starter driven gear boss	O.D.	57.759 – 57.768 (2.2740 – 2.2743)	57.639 (2.2692)	
	I.D.	44.000 – 44.016 (1.7323 – 1.7329)	44.10 (1.736)	



## GENERAL INFORMATION

CRANKSHAFT/TRANSMISSION			Unit: mm (in)		
ITEM		STANDARD	SERVICE LIMIT		
Crankshaft	Connecting rod side clearance	0.10 – 0.25 (0.004 – 0.010)	0.28 (0.011)		
	Crankpin bearing oil clearance	0.032 – 0.062 (0.0015 – 0.0024)	0.070 (0.0028)		
	Main journal bearing oil clearance	0.030 – 0.054 (0.0011 – 0.0021)	0.068 (0.0027)		
	Runout	—	0.05 (0.002)		
Shift fork, fork shaft	I.D.	14.000 – 14.018 (0.5512 – 0.5519)	14.04 (0.553)		
	Claw thickness	5.93 – 6.00 (0.233 – 0.236)	5.83 (0.230)		
	Shift fork shaft O.D.	13.966 – 13.984 (0.5498 – 0.5506)	13.956 (0.5494)		
Transmission	Gear I.D.	M4, M5	31.000 – 31.025 (1.2205 – 1.2215)	31.035 (1.2218)	
		C1	30.000 – 30.025 (1.1811 – 1.1821)	30.035 (1.1825)	
		C2/C3	33.000 – 33.025 (1.2992 – 1.3002)	33.035 (1.3006)	
	Gear bushing O.D.	M4, M5	30.950 – 30.975 (1.2185 – 1.2195)	30.94 (1.218)	
		C1	25.987 – 26.000 (1.0232 – 1.0236)	25.977 (1.0227)	
		C2/C3	32.950 – 32.965 (1.2972 – 1.2978)	32.94 (1.297)	
	Gear-to-bushing clearance	M4, M5	0.025 – 0.075 (0.0010 – 0.0030)	0.095 (0.0037)	
		C2/C3	0.035 – 0.075 (0.0014 – 0.0030)	0.095 (0.0037)	
	Gear bushing I.D.	M4	27.985 – 28.006 (1.1018 – 1.1025)	28.03 (1.104)	
		C1	22.050 – 22.150 (0.8681 – 0.8720)	22.170 (0.8728)	
		C2/C3	30.000 – 30.030 (1.1811 – 1.1823)	30.050 (1.1831)	
	Mainshaft O.D.	at M4	27.959 – 27.980 (1.1007 – 1.1016)	27.940 (1.1000)	
		clutch outer guide	27.980 – 27.993 (1.1016 – 1.1021)	27.970 (1.1012)	
	Countershaft O.D.	at C1	21.980 – 21.993 (0.8653 – 0.8659)	21.97 (0.865)	
		at C2/C3	29.959 – 29.980 (1.1795 – 1.1803)	29.94 (1.179)	
	Bushing-to-shaft clearance	M4	0.005 – 0.047 (0.0002 – 0.0019)	0.067 (0.0026)	
		C1	0.057 – 0.170 (0.0022 – 0.0067)	0.190 (0.0075)	
		C2/C3	0.020 – 0.071 (0.0008 – 0.0028)	0.091 (0.0036)	

FINAL DRIVE			Unit: mm (in)	
ITEM		STANDARD	SERVICE LIMIT	
Recommended final drive oil		Hypoid gear oil, SAE #80	—	
Final drive oil capacity	at disassembly	150 cm <sup>3</sup> (5.1 US oz, 5.3 Imp oz)	—	
	at draining	120 cm <sup>3</sup> (4.1 US oz, 4.2 Imp oz)	—	
Final drive gear backlash		0.05 – 0.15 (0.002 – 0.006)	0.30 (0.012)	
Backlash difference between measurement		—	0.10 (0.004)	
Ring gear-to-stop pin clearance		0.30 – 0.60 (0.012 – 0.024)	—	
Final drive gear assembly preload		0.2 – 0.4 N•m (2 – 4 kgf•cm, 1.7 – 3.5 lbf•ft)	—	

## GENERAL INFORMATION

Unit: mm (in)

<b>FRONT WHEEL/SUSPENSION/STEERING</b>				Unit: mm (in)	
ITEM		STANDARD		SERVICE LIMIT	
Minimum tire tread depth		—		1.5 (0.06)	
Cold tire pressure	Up to 90 kg (200 lb) load	225 kPa (2.25 kgf/cm <sup>2</sup> , 33 psi)		—	
	Up to maximum weight capacity	225 kPa (2.25 kgf/cm <sup>2</sup> , 33 psi)		—	
Axle runout		—		0.2 (0.01)	
Wheel rim runout	Radial	—		2.0 (0.08)	
	Axial	—		2.0 (0.08)	
Wheel balance weight		—		60 g (2.1 oz) max.	
Fork	Spring free length	Right	348.4 (13.72)	341.4 (13.44)	
		Left	348.4 (13.72)	341.4 (13.44)	
	Slider runout		—		0.20 (0.008)
	Recommended fork fluid		Pro Honda Suspension Fluid SS-8		—
	Fluid level	Right	102 (4.1)		—
		Left	101 (4.0)		—
	Fluid capacity	Right	696 ± 2.5 cm <sup>3</sup> (23.5 ± 0.08 US oz, 24.5 ± 0.09 Imp oz)		—
Left		780 ± 2.5 cm <sup>3</sup> (26.4 ± 0.08 US oz, 27.5 ± 0.09 Imp oz)		—	
Steering head bearing pre-load		7.8 – 11.8 N (0.8 – 1.2 kgf)		—	

Unit: mm (in)

<b>REAR WHEEL/SUSPENSION</b>				Unit: mm (in)
ITEM		STANDARD		SERVICE LIMIT
Minimum tire tread depth		—		2.0 (0.08)
Cold tire pressure	Up to 90 kg (200 lb) load	225 kPa (2.25 kgf/cm <sup>2</sup> , 33 psi)		—
	Up to maximum weight capacity	250 kPa (2.50 kgf/cm <sup>2</sup> , 36 psi)		—
Axle runout		—		0.2 (0.01)
Wheel rim runout	Radial	—		2.0 (0.08)
	Axial	—		2.0 (0.08)
Wheel balance weight		—		60 g (2.1 oz) max.
Shock absorber	Spring adjuster standard position	Position 2		—

## GENERAL INFORMATION

Unit: mm (in)

HYDRAULIC BRAKE			STANDARD	SERVICE LIMIT
ITEM				
Front	Specified brake fluid		DOT 4	—
	Brake disc thickness		4.5 (0.18)	3.5 (0.14)
	Brake disc runout		—	0.30 (0.012)
	Master cylinder I.D.		14.000 – 14.043 (0.5512 – 0.5529)	14.055 (0.5533)
	Master piston O.D.		13.957 – 13.984 (0.5495 – 0.5506)	13.94 (0.549)
	Right caliper cylinder I.D.	A	22.650 – 22.700 (0.8917 – 0.8937)	22.710 (0.8941)
		B	27.000 – 27.050 (1.0630 – 1.0650)	27.060 (1.0654)
	Right caliper piston O.D.	A	22.585 – 22.618 (0.8892 – 0.8905)	22.560 (0.8882)
		B	26.935 – 26.968 (1.0604 – 1.0617)	26.910 (1.0594)
	Left caliper cylinder I.D.	A	22.650 – 22.700 (0.8917 – 0.8937)	22.710 (0.8941)
		B	25.400 – 25.450 (1.0000 – 1.0020)	25.460 (1.0024)
	Left caliper piston O.D.	A	22.585 – 22.618 (0.8892 – 0.8905)	22.560 (0.8882)
B		25.335 – 25.368 (0.9974 – 0.9967)	25.320 (0.9968)	
Rear	Specified brake fluid		DOT 4	—
	Brake pedal height		65.0 ± 1.0 (2.56 ± 0.03)	—
	Brake disc thickness		7.0 (0.28)	6.0 (0.24)
	Brake disc runout		—	0.30 (0.012)
	Master cylinder I.D.		17.460 – 17.503 (0.6874 – 0.6891)	17.515 (0.6896)
	Master piston O.D.		17.417 – 17.444 (0.6857 – 0.6868)	17.405 (0.6852)
	Caliper cylinder I.D.		33.960 – 34.010 (1.3370 – 1.3390)	34.020 (1.3394)
	Caliper piston O.D.		33.878 – 33.928 (1.3338 – 1.3357)	33.870 (1.3335)

BATTERY/CHARGING SYSTEM			SPECIFICATIONS
ITEM			
Battery	Capacity		12V – 18 Ah
	Current leakage		0.1 mA max.
	Voltage (20°C/68°F)	Fully charged	13.0 – 13.2 V
		Needs charging	Below 12.3 V
	Charging current	Normal	1.8 A/5 – 10 h
Quick		9.0 A/1.0 h	
Alternator	Capacity		0.4 kW/5,000 rpm
	Charging coil resistance (20°C/68°F)		0.1 – 1.0 Ω

**IGNITION SYSTEM**

ITEM		SPECIFICATIONS
Spark plug	Standard	IFR6L11 (NGK)      VK20PRZ11 (DENSO)
	For cold climate/below 5°C/41°F	IFR5L11 (NGK)      VK16PRZ11 (DENSO)
	For extended high speed riding	IFR7L11 (NGK)      VK22PRZ11 (DENSO)
Spark plug gap		1.0 – 1.1 mm (0.039 – 0.043 in)
Ignition coil peak voltage		100 V minimum
Ignition pulse generator peak voltage		0.7 V minimum
Ignition timing ("F" mark)		8 ° BTDC at idle

Unit: mm (in)

**ELECTRIC STARTER**

ITEM	STANDARD	SERVICE LIMIT
Starter motor brush length	12.0 – 13.0 (0.47 – 0.51)	4.5 (0.18)

**LIGHTS/METERS/SWITCHES**

ITEM		SPECIFICATIONS	
Bulbs	Headlight	Hi	12V – 60W
		Lo	12V – 55W
	Brake/tail light		12V – 21/5W
	Front turn signal/running light		12V – 21/5W x 2
	Rear turn signal light		12V – 21W x 2
	License light		12V – 5W
	Instrument light		L.E.D.
	Turn signal indicator		L.E.D.
	High beam indicator		L.E.D.
	Neutral indicator		L.E.D.
	Oil pressure indicator		L.E.D.
	PGM-FI warning indicator		L.E.D.
	Coolant temperature indicator		L.E.D.
	Fuel reserve indicator		L.E.D.
Fuse	Main fuse		30 A
	PGM-FI fuse		30 A
	Sub fuse		10 A x 4, 20 A x 2
Fan motor switch	Start to close (ON)		98 – 102 °C (208 – 216 °F)
	Stop to open		93 – 97 °C (199 – 207 °F)



## GENERAL INFORMATION

### TORQUE VALUES

FASTENER TYPE	TORQUE N·m (kgf·m, lbf·ft)	FASTENER TYPE	TORQUE N·m (kgf·m, lbf·ft)
5 mm hex bolt and nut	5 (0.5, 3.6)	5 mm screw	4 (0.4, 2.9)
6 mm hex bolt and nut	10 (1.0, 7)	6 mm screw	9 (0.9, 6.5)
8 mm hex bolt and nut	22 (2.2, 16)	6 mm flange bolt (8 mm head, small flange)	10 (1.0, 7)
10 mm hex bolt and nut	34 (3.5, 25)	6 mm flange bolt (8 mm head, large flange)	12 (1.2, 9)
12 mm hex bolt and nut	54 (5.5, 40)	6 mm flange bolt (10 mm head) and nut	12 (1.2, 9)
		8 mm flange bolt and nut	26 (2.7, 20)
		10 mm flange bolt and nut	39 (4.0, 29)

- Torque specifications listed below are for important fasteners.
- Others should be tightened to standard torque values listed above.

- NOTES:
1. Apply sealant to the threads.
  2. Apply a locking agent to the threads.
  3. Stake.
  4. Apply oil to the threads and flange surface.
  5. U-nut.
  6. ALOC bolt/screw: replace with a new one.
  7. Apply grease to the threads.
  8. Apply molybdenum disulfide oil to the threads and seating surface
  9. CT bolt

ENGINE	ITEM	Q'TY	THREAD DIA. (mm)	TORQUE N·m (kgf·m, lbf·ft)	REMARKS
	<b>LUBRICATION SYSTEM:</b>				
	Front oil drain bolt	1	12	29 (3.0, 22)	
	Rear oil drain bolt	1	12	29 (3.0, 22)	
	Oil pump assembly bolt	1	6	13 (1.3, 9)	
	Oil pump driven sprocket bolt	1	6	18 (1.8, 13)	NOTE 2
	Oil strainer bolt	1	6	13 (1.3, 9)	
	Oil filter boss	1	20	18 (1.8, 13)	NOTE 2
	Oil filter cartridge	1	20	26 (2.7, 20)	NOTE 4
	Oil pressure switch	1	PT 1/8	12 (1.2, 9)	NOTE 1
	Oil pressure switch wire terminal screw	1	4	2 (0.2, 1.4)	
	<b>COOLING SYSTEM:</b>				
	Water pump assembly bolt	2	6	13 (1.3, 9)	
	<b>CYLINDER HEAD/VALVES:</b>				
	Spark plug	4	14	18 (1.8, 13)	
	Spark plug sleeve	2	30	18 (1.8, 13)	NOTE 4
	Reed valve cover bolt	4	5	5.1 (0.52, 3.8)	
	Cylinder head cover bolt (8 mm)	4	8	26 (2.7, 20)	
	Cylinder head cover bolt (6 mm)	16	6	12 (1.2, 9)	
	Cylinder head nut (10 mm)	8	10	49 (5.0, 39)	NOTE 4
	Cylinder head nut (8 mm)	4	8	26 (2.7, 20)	NOTE 4
	Camshaft holder bolt	12	8	26 (2.7, 20)	NOTE 4
	Cam sprocket bolt	4	7	23 (2.3, 17)	
	Valve adjusting screw lock nut	6	—	22 (2.2, 16)	
	Cam chain tensioner bolt	4	6	12 (1.2, 9)	

ENGINE (cont'd)				
ITEM	Q'TY	THREAD DIA. (mm)	TORQUE N•m (kgf•m, lbf•ft)	REMARKS
<b>CLUTCH/GEARSHIFT LINKAGE:</b>				
Clutch lifter plate bolt	5	6	12 (1.2, 9)	
Clutch center lock nut	1	25	186 (19.0, 137)	NOTE 3, 4
Primary drive gear bolt	1	12	137 (14.0, 101)	NOTE 4
Primary driven gear nut	1	25	186 (19.0, 137)	NOTE 3, 4
Shift drum stopper arm bolt	1	6	12 (1.2, 9)	
Shift drum center socket bolt	1	8	23 (2.3, 17)	NOTE 2
Shift return spring pin	1	8	23 (2.3, 17)	
Change pedal pinch bolt	1	6	12 (1.2, 9)	
Slave cylinder bleed valve	1	8	6 (0.6, 4.3)	
<b>ALTERNATOR/STARTER CLUTCH:</b>				
Crankshaft hole cap	1	45	18 (1.8, 13)	NOTE 7
Flywheel bolt	1	12	137 (14.0, 101)	NOTE 4
Starter clutch outer bolt	6	8	29 (3.0, 22)	NOTE 2
Balancer weight bolt	1	12	98 (10.0, 72)	
<b>CRANKCASE/TRANSMISSION:</b>				
Right crankcase bolt	14	8	26 (2.7, 20)	
Left crankcase bolt	1	8	26 (2.7, 20)	
Left crankcase oil orifice bolt	1	8	14 (1.4, 10)	
Connecting rod bearing cap bolt	4	10	49 (5.0, 36)	NOTE 4
Output gear case mounting bolt	4	8	31 (3.2, 23)	
Output drive gear bearing holder bolt	2	8	31 (3.2, 23)	
Output drive gear bearing holder socket bolt	4	8	31 (3.2, 23)	
<b>ELECTRIC STARTER:</b>				
Starter motor cable terminal nut	1	6	7 (0.7, 5.1)	
Starter motor case bolt	2	5	5 (0.5, 3.6)	
<b>LIGHTS/METERS/SWITCHES:</b>				
Neutral switch	1	10	12 (1.2, 9)	

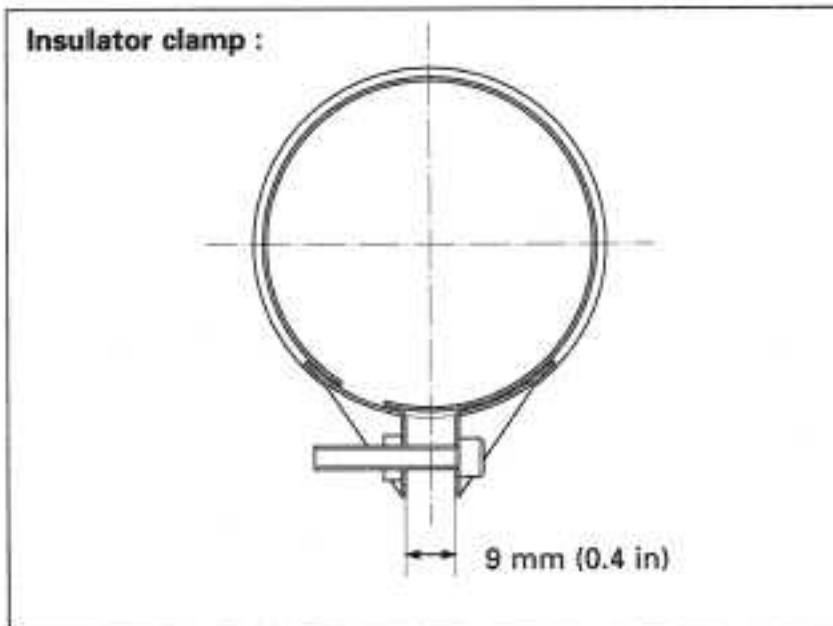

## GENERAL INFORMATION

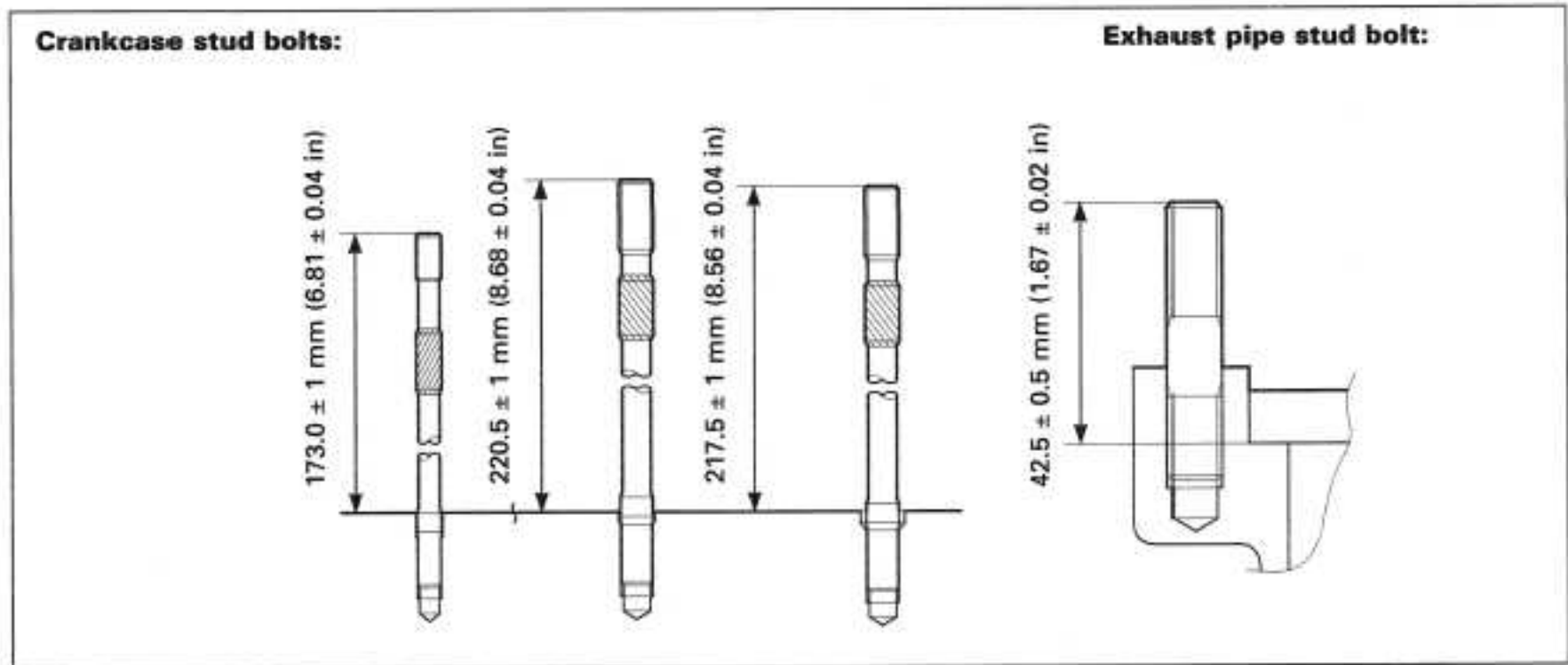

FRAME					
ITEM	Q'TY	THREAD DIA. (mm)	TORQUE N·m (kgf·m, lbf·ft)	REMARKS	
<b>FRAME BODY PANELS/EXHAUST SYSTEM:</b>					
Exhaust pipe joint nut	4	8	23 (2.3, 17)	NOTE 5	
Muffler band bolt	3	8	17 (1.7, 12)		
Muffler stay nut	2	8	34 (3.5, 25)		
<b>FUEL SYSTEM (Programmed Fuel Injection):</b>					
Air cleaner housing cover bolt	5	5	3.4 (0.35, 2.5)		
Fuel tank rear mounting bolt	1	6	12 (1.2, 9)		
Fuel hose banjo bolt (fuel tank side)	1	12	22 (2.2, 16)		
Fuel hose sealing nut (throttle body side)	1	12	22 (2.2, 16)		
ECT sensor	1	16	18 (1.8, 13)		
Starter valve screw	2	5	3.4 (0.35, 2.5)		
MAP sensor screw	2	4	2.1 (0.21, 1.5)		
Throttle cable guide screw	2	5	3.4 (0.35, 2.5)		
Fuel pump mounting nut	8	6	12 (1.2, 9)		
O <sub>2</sub> sensor	2	12	24.5 (2.5, 18)		
<b>COOLING SYSTEM:</b>					
Radiator cover bolt	3	6	10 (1.0, 7)		
Radiator cover side bolt	4	6	3.4 (0.35, 2.5)		

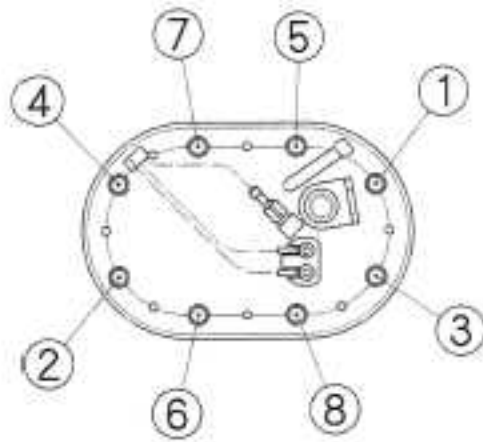

FRAME (cont'd)				
ITEM	Q'TY	THREAD DIA. (mm)	TORQUE N·m (kgf·m, lbf·ft)	REMARKS
<b>ENGINE MOUNTING:</b>				
Front upper engine mounting nut	1	12	54 (5.5, 40)	
Front lower engine mounting nut	1	12	54 (5.5, 40)	
Rear upper engine mounting nut	1	12	54 (5.5, 40)	
Rear lower engine mounting nut	1	12	54 (5.5, 40)	
Right front upper engine hanger plate bolt	2	8	26 (2.7, 20)	
Left front upper engine hanger plate bolt	2	8	26 (2.7, 20)	
Right front lower engine hanger plate bolt	2	10	39 (4.0, 29)	NOTE 5
Rear upper engine hanger plate bolt	4	8	26 (2.7, 20)	
Rear lower engine hanger plate bolt	4	8	26 (2.7, 20)	
<b>CLUTCH/GEARSHIFT LINKAGE:</b>				
Clutch master cylinder holder bolt	2	6	12 (1.2, 9)	
Clutch master cylinder reservoir cap screw	2	4	1.5 (0.15, 1.1)	
Clutch lever pivot bolt	1	6	1 (0.1, 0.7)	
Clutch lever pivot nut	1	6	6 (0.6, 4.3)	
Clutch switch screw	1	4	1.2 (0.12, 0.9)	
Clutch hose oil bolt	2	10	34 (3.5, 25)	
<b>FINAL DRIVE:</b>				
Final gear case mounting nut	4	10	64 (6.5, 47)	UBS nut
Final drive oil filler cap	1	30	12 (1.2, 9)	
Final drive oil drain bolt	1	14	20 (2.0, 14)	
Gear case cover bolt (10 mm)	2	10	62 (6.3, 46)	NOTE 2
Gear case cover bolt (8 mm)	6	8	25 (2.6, 19)	
Pinion retainer	1	70	147 (15.0, 108)	
Pinion joint nut	1	16	108 (11.0, 80)	NOTE 2
Pinion retainer lock tab bolt	1	6	10 (1.0, 7)	
Dust guard plate bolt	1	6	10 (1.0, 7)	
<b>FRONT WHEEL/SUSPENSION/STEERING:</b>				
Handlebar upper holder bolt	4	8	26 (2.7, 20)	
Handlebar lower holder nut	2	12	64 (6.5, 47)	NOTE 5
Front axle bolt	1	14	90 (9.2, 67)	
Front axle holder bolt	4	8	22 (2.2, 16)	
Front brake disc bolt	12	6	20 (2.0, 14)	NOTE 6
Steering stem nut	1	24	100 (10.2, 74)	(page 13-37)
Top adjusting nut A	1	26	17 (1.7, 12)	
Top adjusting nut B	1	26	—	
Fork top bridge pinch bolt	2	10	55 (5.6, 41)	
Fork bottom bridge pinch bolt	4	8	24 (2.4, 17)	
Fork cap	2	50	34 (3.5, 25)	
Fork cap lock nut	2	10	20 (2.0, 14)	
Fork socket bolt	1	8	20 (2.0, 14)	NOTE 2
Inner fork bolt	1	43	98 (10.0, 72)	
<b>REAR WHEEL/SUSPENSION:</b>				
Rear axle nut	1	18	110 (11.2, 81)	NOTE 5
Rear brake disc bolt	6	8	42 (4.3, 31)	NOTE 6
Driven flange nut	5	12	88 (9.0, 65)	NOTE 5
Left swingarm pivot bolt	1	30	103 (10.5, 76)	
Right swingarm pivot bolt	1	30	14 (1.4, 10)	
Right swingarm pivot lock nut	1	30	113 (11.5, 83)	
Rear shock absorber mounting bolt	4	8	26 (2.7, 20)	
Rear shock absorber lower mounting bolt (final gear case side)	1	12	54 (5.5, 40)	NOTE 2



## GENERAL INFORMATION

<b>FRAME (cont'd)</b>				
ITEM	QTY	THREAD DIA. (mm)	TORQUE N·m (kgf·m, lbf·ft)	REMARKS
<b>HYDRAULIC BRAKE:</b>				
Brake pad pin	3	10	18 (1.8, 13)	
Brake caliper bleed valve	5	8	6 (0.6, 4.3)	
Brake hose oil bolt	7	10	34 (3.5, 25)	
Brake pipe joint bolt	12	10	17 (1.7, 12)	NOTE 4
Brake pipe 2/3 way joint	7	6	12 (1.2, 9)	
Brake hose clamp/stay bolt	6	6	12 (1.2, 9)	
Brake hose guide bolt	1	8	21 (2.1, 15)	NOTE 6
PCV (Proportional Control Valve) mounting bolt	2	6	12 (1.2, 9)	
Front master cylinder holder bolt	2	6	12 (1.2, 9)	
Front master cylinder reservoir cap screw	2	4	1.5 (0.15, 1.1)	
Front brake lever pivot bolt	1	6	1 (0.1, 0.7)	
Front brake lever pivot nut	1	6	6 (0.6, 4.3)	
Front brake light switch screw	1	4	1.2 (0.12, 0.9)	
Rear master cylinder reservoir cover bolt	1	6	10 (1.0, 7)	
Rear master cylinder reservoir hose joint screw	1	4	1.5 (0.15, 1.1)	NOTE 2
Rear master cylinder mounting bolt	2	6	12 (1.2, 9)	
Rear master cylinder push rod lock nut	1	8	18 (1.8, 13)	
Front caliper mounting bolt	4	8	30 (3.1, 22)	NOTE 6
Front caliper body B bolt	6	8	23 (2.3, 17)	NOTE 6
Front caliper pin bolt A	2	8	23 (2.3, 17)	NOTE 2
Front caliper pin bolt	2	8	13 (1.3, 9)	NOTE 2
Rear caliper pin bolt	1	12	27 (2.8, 20)	
Rear caliper bracket pin bolt	1	8	23 (2.3, 17)	NOTE 2
Rear caliper stopper pin bolt	1	18	69 (7.0, 51)	NOTE 6
Brake pedal pivot bolt	1	8	21 (2.1, 15)	
<b>LIGHTS/METERS/SWITCHES:</b>				
Speedometer/indicator box socket bolt	5	5	2.5 (0.25, 1.8)	
Speedometer/indicator box screw	2	5	1.3 (0.13, 0.9)	
Ignition switch mounting bolt	2	6	10 (1.0, 7)	
Ignition switch rear cover screw	4	4	2 (0.2, 1.4)	
Horn mounting bolt	1	8	21 (2.1, 15)	
Fan motor switch	1	16	17 (1.7, 12)	
Side stand switch bolt	1	6	10 (1.0, 7)	NOTE 6
Speedometer/indicator box stay screw	2	4	1.2 (0.12, 0.9)	
<b>OTHERS:</b>				
Side stand pivot bolt	1	10	10 (1.0, 7)	
Side stand lock nut	1	10	30 (3.1, 22)	NOTE 5
Side stand bracket bolt	3	10	39 (4.0, 29)	
Step holder bolt	4	10	39 (4.0, 29)	
Pillion step holder bolt	2	8	27 (2.8, 20)	
Change pivot shaft	1	8	27 (2.8, 20)	

## TOOLS

- NOTES: 1. Equivalent commercially available in U.S.A.  
 2. Not available in U.S.A.  
 3. Alternative tool.  
 4. Newly designed tool.

DESCRIPTION	TOOL NUMBER	REMARKS	REF. SEC.
Fuel pressure gauge	07406-004000A		5
Oil pressure gauge	07506-3000001	NOTE 1	4
Oil pressure gauge attachment	07510-4220100	NOTE 1	4
Gear holder	07724-0010100	NOTE 2	10, 18
Flywheel holder	07725-0040000		18
Flywheel puller	07733-0020001	NOTE 3: 07933-3290001	18
Remover weight	07936-371020A	NOTE 3: 07936-3710200	11, 18
Attachment, 32 x 35 mm	07746-0010100		10, 11
Attachment, 37 x 40 mm	07746-0010200		13, 14
Attachment, 42 x 47 mm	07746-0010300		11, 13, 14
Attachment, 52 x 55 mm	07746-0010400		11, 12, 13, 14
Attachment, 62 x 68 mm	07746-0010500		11
Attachment, 72 x 75 mm	07746-0010600		12
Attachment, 24 x 26 mm	07746-0010700		14, 18
Driver, 40 mm I.D.	07746-0030100		12
Attachment, 30 mm I.D.	07746-0030300		12
Pilot, 10 mm	07746-0040100		18
Pilot, 17 mm	07746-0040400		10, 11
Pilot, 20 mm	07746-0040500		11, 13, 14
Pilot, 25 mm	07746-0040600		11
Pilot, 30 mm	07746-0040700		14
Pilot, 35 mm	07746-0040800		12, 13
Pilot, 22 mm	07746-0041000		11
Pilot, 28 mm	07746-0041100		11
Bearing remover head, 20 mm	07746-0050600		13, 14
Driver	07749-0010000		10, 11, 12, 13, 14, 18
Valve spring compressor	07757-0010000		8
Valve seat cutter		NOTE 1	8
Seat cutter, 40 mm (45° IN)	07780-0010500		
Seat cutter, 46 mm (45° EX)	07780-0011200	NOTE 4	
Flat cutter, 38.5 mm (32° IN)	07780-0012400		
Flat cutter, 50 mm (32° EX)	07780-0013600	NOTE 4	
Interior cutter, 34 mm (60° IN)	07780-0014700		
Interior cutter, 45 mm (60° IN)	07780-0014800	NOTE 4	
Cutter holder, 6.6 mm	07781-0010202	NOTE 3: 07942-ZE2000D (U.S.A. only)	8
Pilot screw wrench	07908-4730002		5
Lock nut	07908-4690003		14
Valve adjusting screw wrench, 4 mm	07908-KE90100		3
Retainer wrench	07910-4630100		12
Snap ring pliers	07914-SA50001		10, 15
Steering stem socket	07916-3710100		13
Mainshaft holder	07923-6890101	U.S.A. only	11
Pinion holder plate	07924-ME40010		12
Collar set "C"	07924-ME40020		12
Holder attachment	07930-KA50100		8
Special nut	07931-HB3020A		12
Puller shaft	07931-ME4010B		12
Remover handle	07936-3710100		11, 12
Remover weight	07936-371020A	NOTE 3: 07936-3710200	12
Bearing remover	07936-3710300		11, 12
Bearing remover, 22 mm	07936-3710600		11
Remover shaft	07936-GE00100	NOTE 1	18
Remover head	07936-GE00200	NOTE 1	18
Valve guide driver, 6.6 mm	07942-6570100		8

## GENERAL INFORMATION

DESCRIPTION	TOOL NUMBER	REMARKS	REF. SEC.
Steering stem driver	07946-MB00000		13
Bearing race remover	07946-3710500		13
Driver	07949-3710001		12, 13, 14
Bearing puller driver attachment	07965-MB00100		12
Oil seal driver	07965-MC70100		12
Valve guide reamer, 6.6 mm	07984-657010D		8
Bearing driver attachment	07GAD-SD40101		12
Bearing remover shaft	07GGD-0010100		13, 14
Oil filter wrench	07HAA-PJ70101	NOTE 3: 07HAA-PJ70100	3
Peak voltage adapter	07HGJ-0020100	NOTE3: Peak voltage tester	5, 17
Puller base	07HMC-MM8011A		12
Holder plate	07HGB-001010B	NOTE 3: 07HGB-001010A	10
Holder collar	07HGB-001020B	NOTE 3: 07HGB-001020A	10
Fork seal driver, 45 mm	07KMD-KZ30100		13
Vacuum gauge set	07LMJ-001000A		5
Case puller	07SMC-0010001		12
Lock nut wrench, 36 x 44 mm	07VMA-MZ0010A		13
Torque limiter inspection tool A	07YMJ-MCF0100	NOTE 2	18
Torque limiter inspection tool B	07YMJ-MCF0200	NOTE 2	18
ECU test harness	07YMZ-0010100		5
Valve guide driver, 8 mm	07ZMD-MCHA100	NOTE 4	8
Cutter holder, 8 mm	07ZMH-MCH0100	NOTE 1	8
Valve guide reamer, 8 mm	07ZMH-MCHA200		8
Battery tester	BM-210-AH	NOTE3: BM-210 (U.S.A. only)	16

**LUBRICATION & SEAL POINTS**

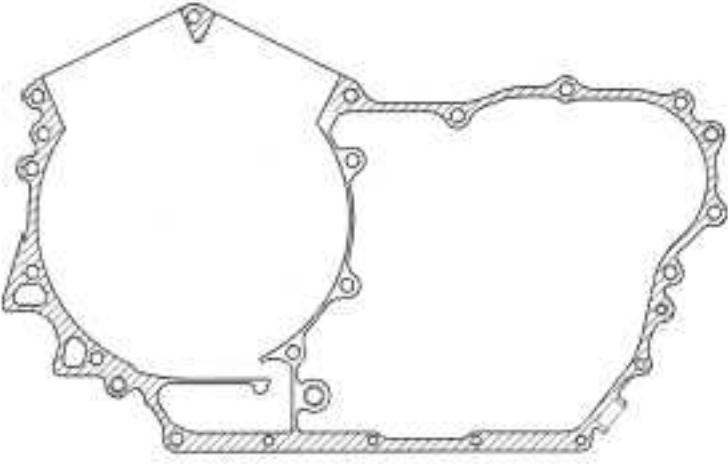
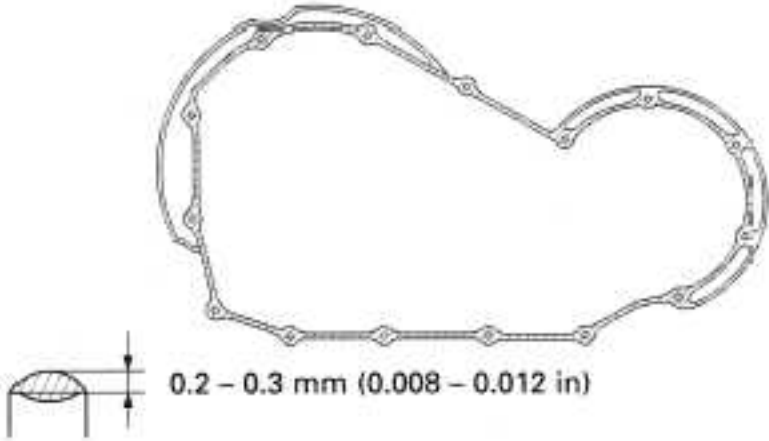
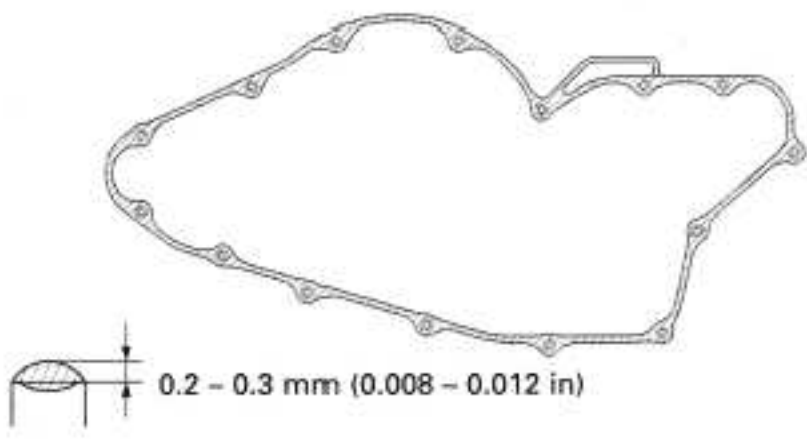
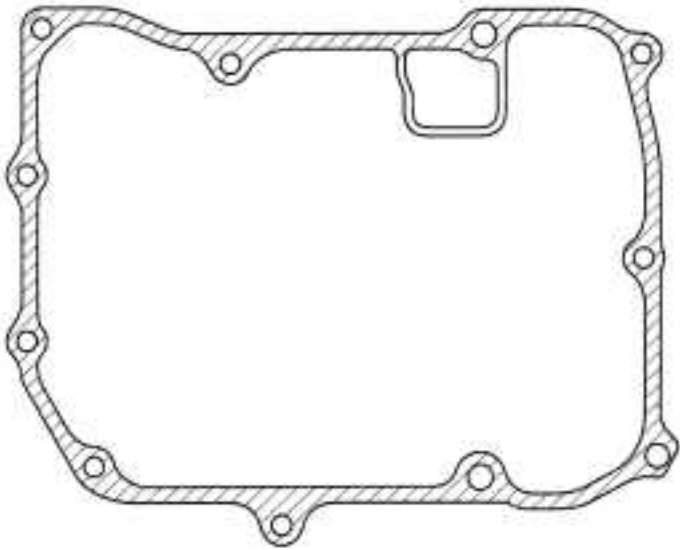
ENGINE	LOCATION	MATERIAL	REMARKS
<p>Right and left crankcase mating surface</p> 	<p>Liquid sealant (Three Bond 1207B or equivalent)</p>		
<p>Right and left crankcase cover mating surface</p> <p>Right crankcase cover:</p> 	<p>Left crankcase cover:</p> 		
<p>Cylinder head cover mating surface</p> 			

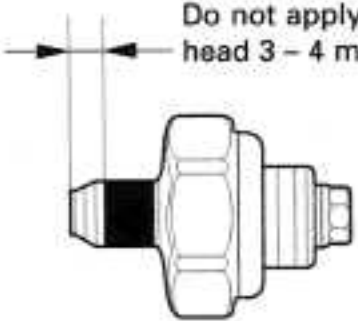

## GENERAL INFORMATION

ENGINE (cont'd)		
LOCATION	MATERIAL	REMARKS
Ignition pulse generator grommet seating surface Alternator grommet seating surface Oil pressure switch threads   <p>Do not apply sealant to the thread head 3 - 4 mm (0.1 - 0.2 in).</p>	Liquid sealant (Three Bond 1207B or equivalent)	
Crankshaft bearing thrust surface Crankshaft journals and pins Connecting rod bearing thrust surface Connecting rod small end inner surface Intake and exhaust valve sliding surface Camshaft journals and robes Rocker arm shaft outer surface Rocker arm slipper surface Clutch outer sliding surface Clutch outer guide sliding surface M2/3, C4, C5 shifter gear (shift fork grooves) Transmission spline collar outer surface Transmission collar inner and outer surface Starter reduction gear shaft outer surface Each oil seal lip	Molybdenum disulfide oil (a 1:1 mixture of engine oil and molybdenum disulfide grease)	
Piston outer surface and piston pin hole Piston ring outer surface Piston pin outer surface Connecting rod bearing cap bolt threads and seating surface Oil filter cartridge threads and mating surface Clutch disc lining surface Clutch center lock nut threads and seating surface Primary driven sprocket nut threads and seating surface Balancer weight bolt threads and seating surface Crankcase stud bolt threads Gearshift fork sliding surface Valve adjusting screw threads and seating surface Spark plug sleeve threads and O-rings Flywheel bolt threads and seating surface Primary drive gear bolt threads and seating surface Each bearing Each gear Each O-ring Other sliding and rotating surfaces	Engine oil	
Crankshaft hole cap threads Oil seal lips	Multi-purpose grease	

**ENGINE (cont'd)**

LOCATION	MATERIAL	REMARKS
Oil filter boss case side threads Cam sprocket bolt threads Oil pump driven sprocket bolt threads Shift drum center socket bolt threads Starter clutch outer bolt threads Stator bolt threads Stator wire clamp bolt threads Ignition pulse generator bolt threads and seating surface Bearing set plate A bolt threads Bearing set plate B bolt threads Oil pump chain guide bolt threads	Locking agent	Coating width: 6.5 ± 1 mm

## GENERAL INFORMATION

FRAME	LOCATION	MATERIAL	REMARKS
	Final gear case-to-case cover mating surface	Liquid sealant	
	Side stand pivot surface Throttle grip pipe flange cable groove Step pivot surface Pillion step pivot surface Brake pedal pivot surface Change pedal pivot surface Front wheel dust seal lips Rear wheel dust seal lips Final gear case oil seal lips	Multi-purpose grease	Apply 1 g Apply 0.2 – 0.3 g
	Gearshift tie-rod ball joints Steering head bearing rolling area Steering head bearing dust seal lips Swingarm pivot bearing rolling area Swingarm pivot bearing dust seal lips Final drive shaft spline (universal joint) Output driven gear shaft spline (universal joint)	Multi-purpose grease (Shell Albania EP2 or equivalent)	Apply 3 g  Apply 1 – 1.5 g  Apply 1 g Apply 1 g
	Rear wheel hub-to-final driven flange mating surface Final driven flange O-ring, O-ring groove Final driven flange sliding portion Final drive pinion joint spline Final gear case ring gear shaft spline (final driven flange side)	Molybdenum disulfide paste (containing more than 40% molybdenum disulfide)	Apply 3 g   Apply 2 g Apply 5 g
	Throttle cables Speedometer cable	Cable lubricant	
	Right and left handlebar grip rubber inner surface	Honda bond A or Honda Hand Grip Cement (U.S.A. only)	
	Steering stem top thread A threads	Engine oil	
	Front caliper pin bolt and pin bolt A sliding portion Rear caliper pin bolt and bracket pin bolt sliding portion Caliper piston seals Brake lever pivot Front brake lever-to-piston contacting portion Clutch lever pivot Clutch lever-to-piston contacting portion	Silicone grease	Apply 0.4 g  Apply 0.1 g Apply 0.1 g Apply 0.1 g Apply 0.1 g
	Caliper pistons Brake master cylinder piston and cups Clutch master cylinder piston and cups	DOT 4 brake fluid	
	Fork dust seal lips Fork oil seal lips	Pro Honda Suspension Fluid SS-8	
	Front caliper pin bolt and pin bolt A threads Rear caliper bracket pin bolt threads Fork socket bolt threads Final driven flange stud bolt threads (gear case side) Final gear case cover 10 mm bolt threads Final drive pinion gear shaft nut threads Rear shock absorber lower mounting 12 mm bolt threads (final gear case side)	Locking agent	

CABLE & HARNESS ROUTING

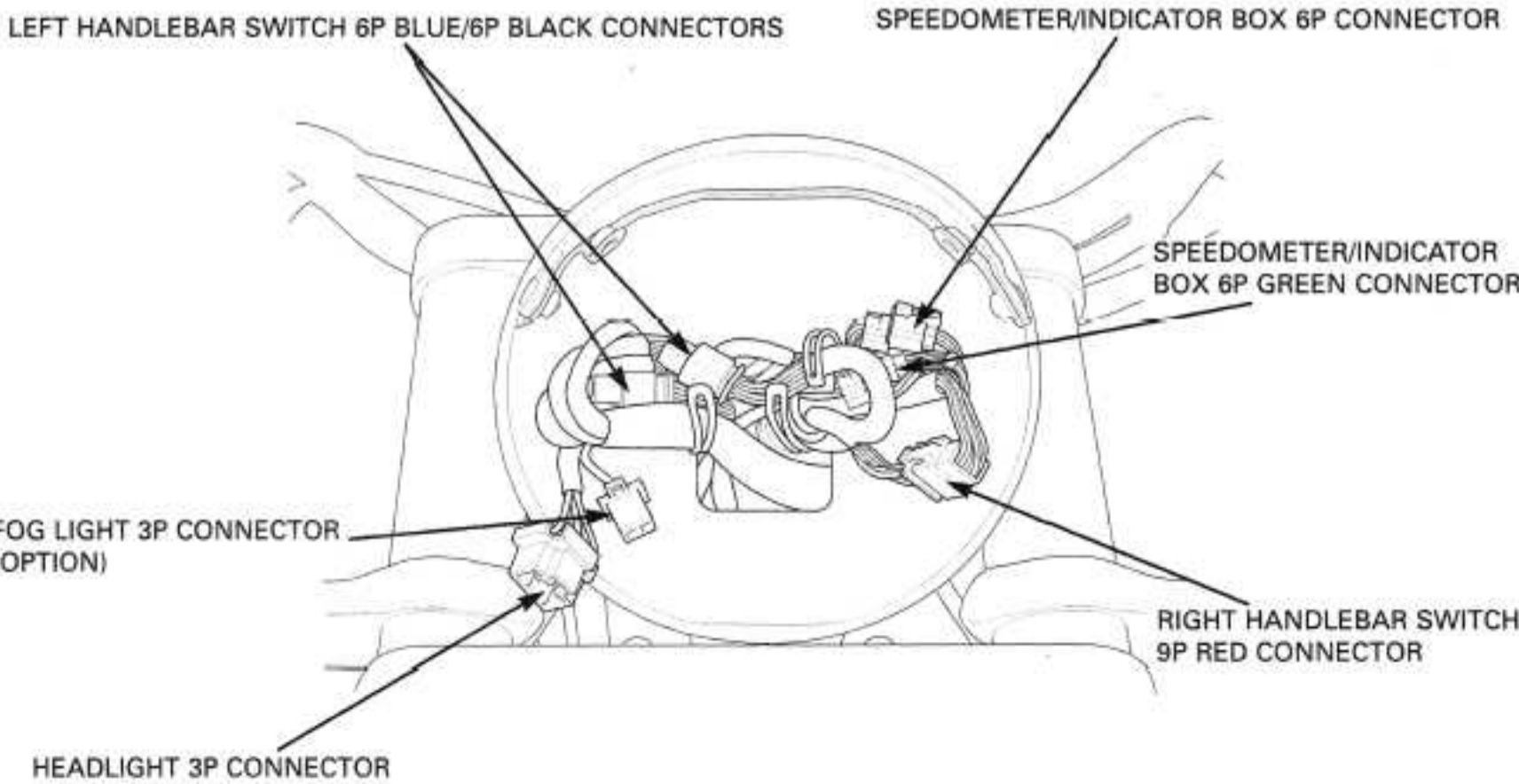
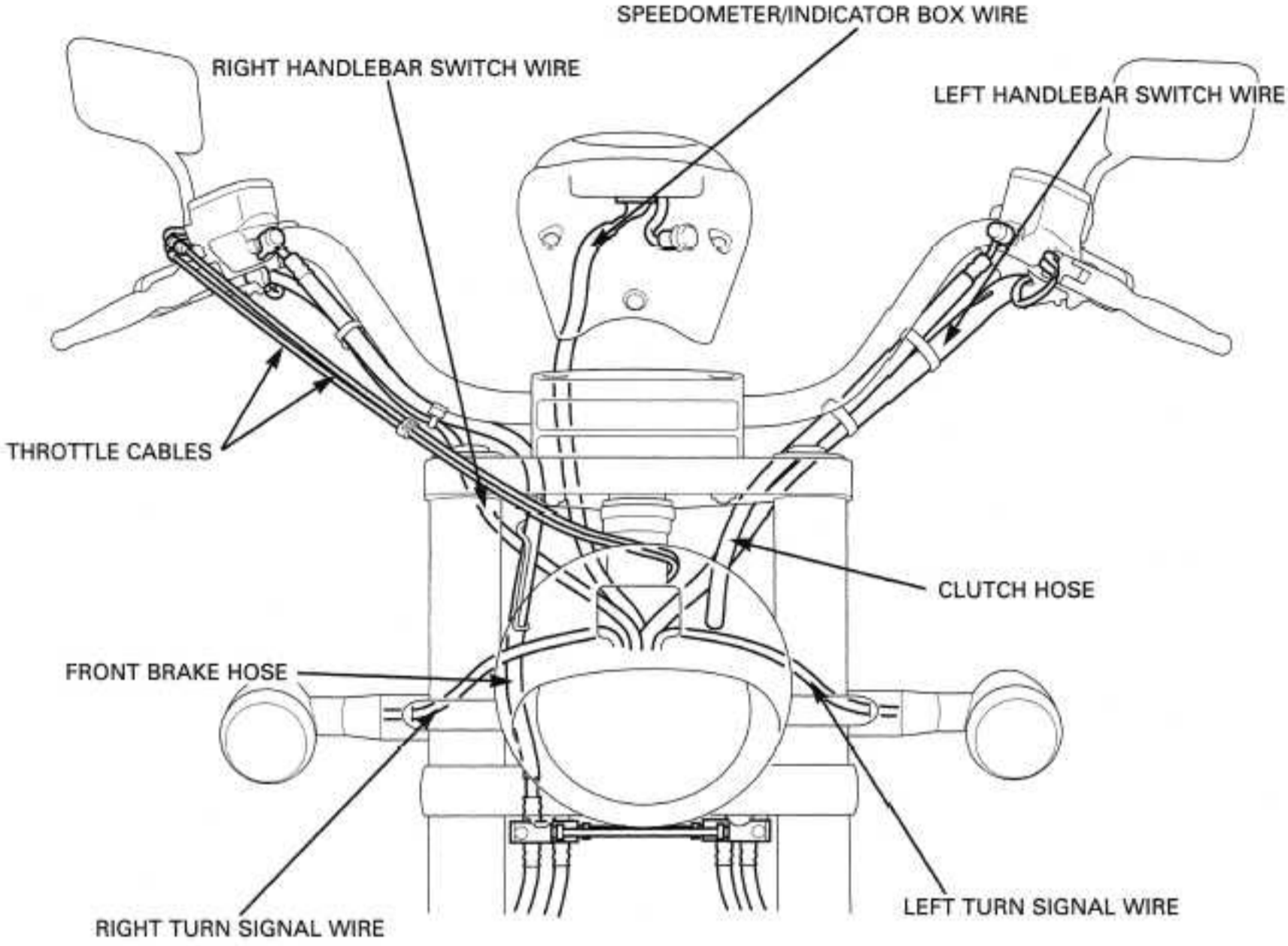



## GENERAL INFORMATION

---

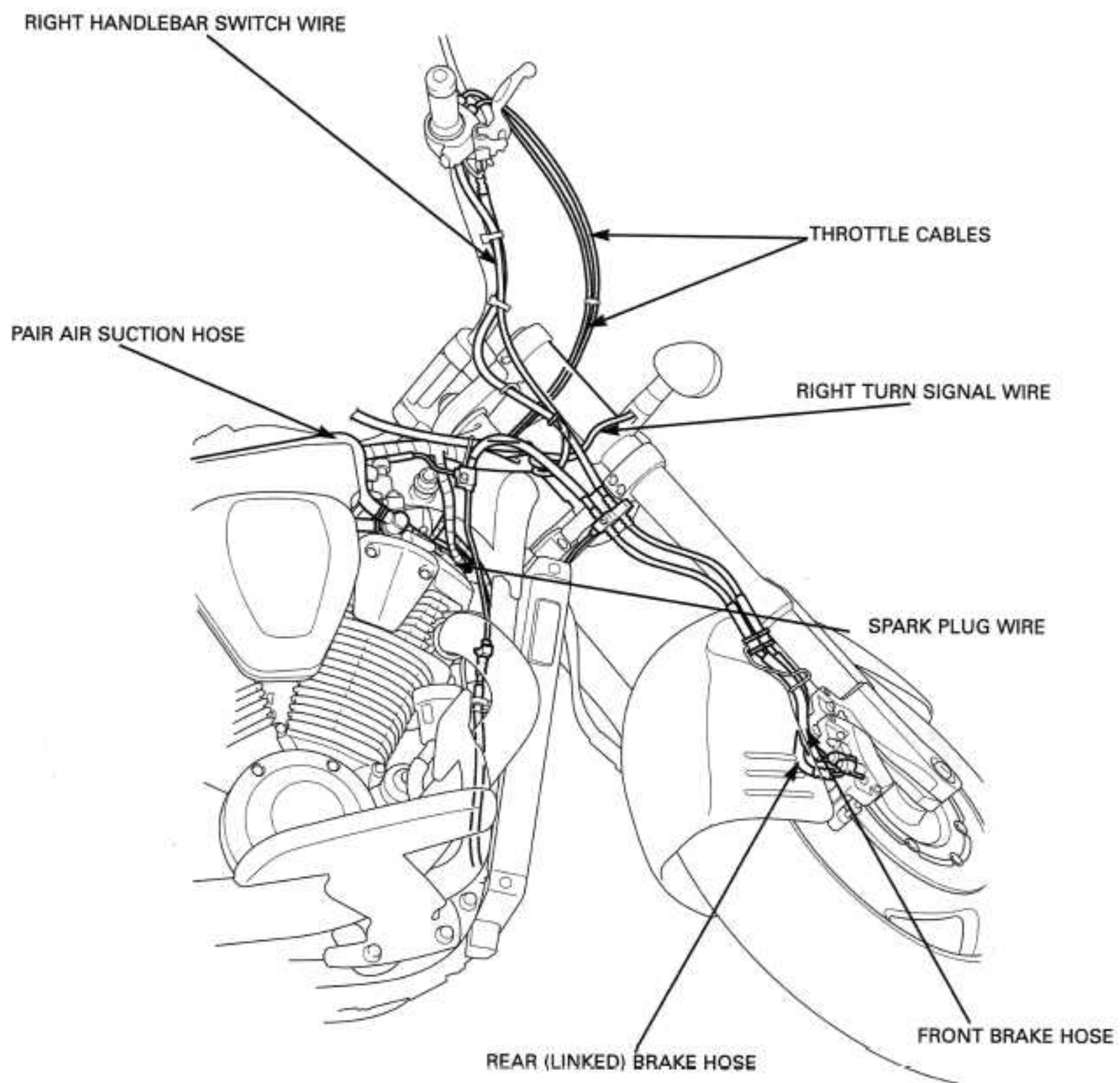

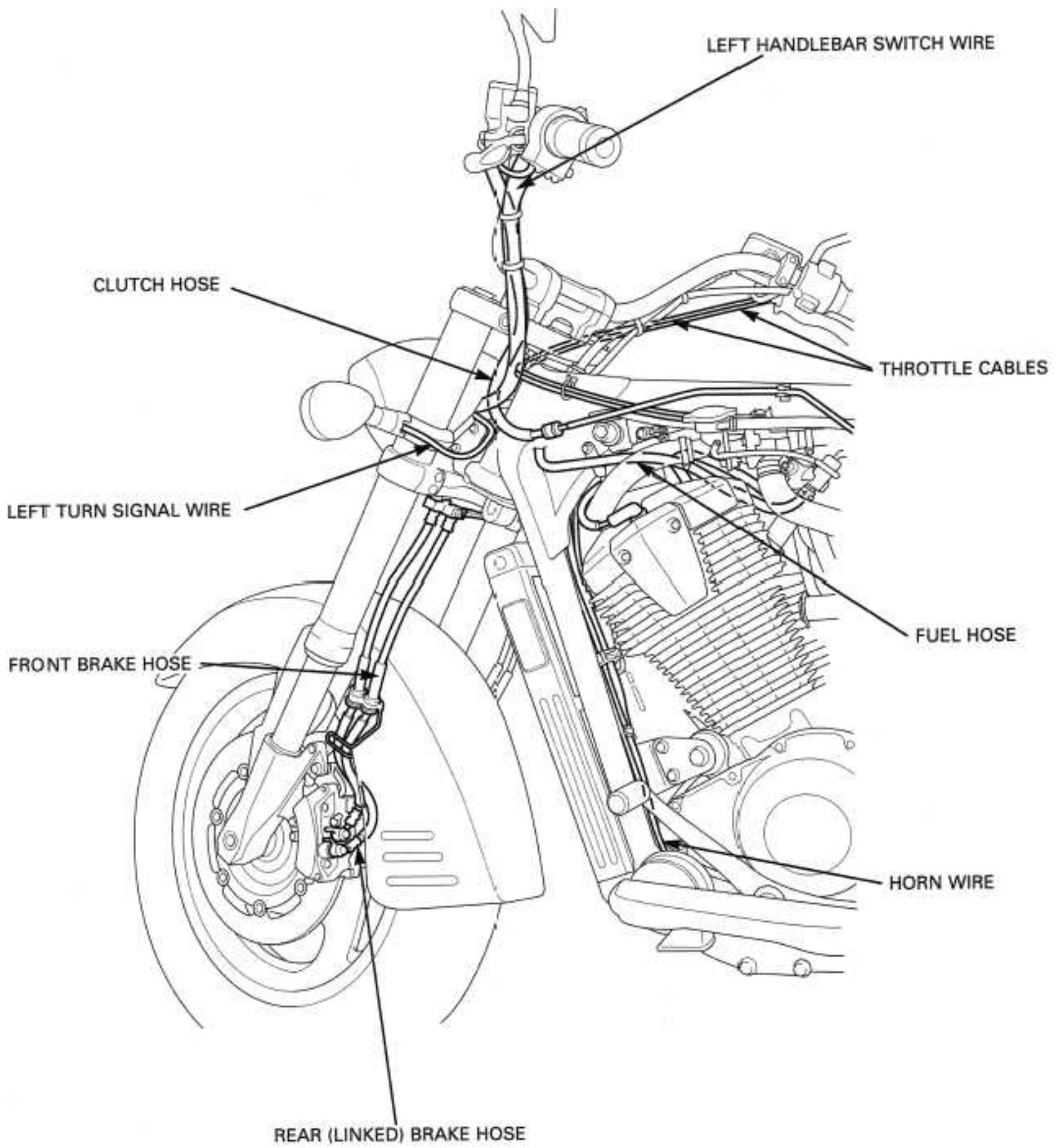

# GENERAL INFORMATION

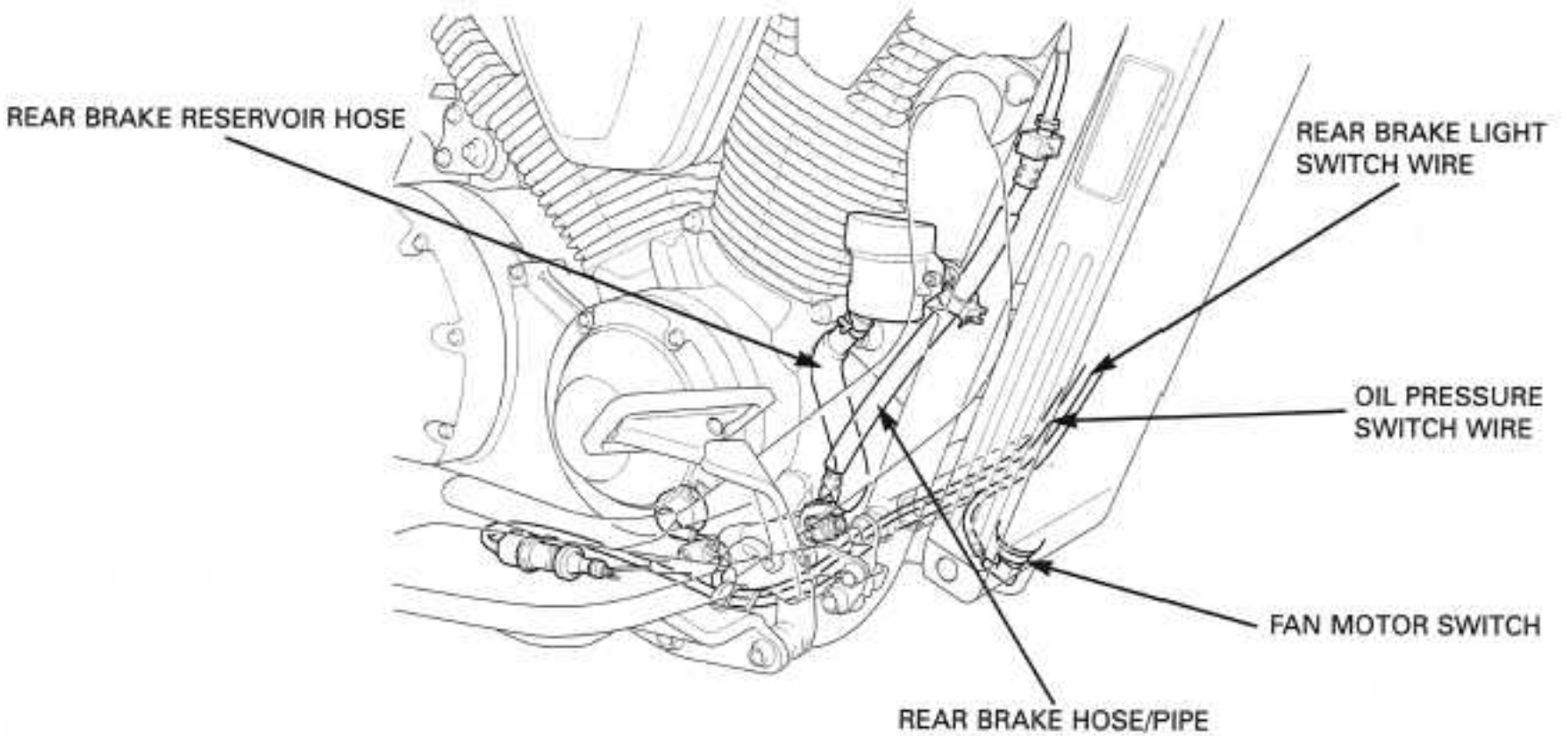
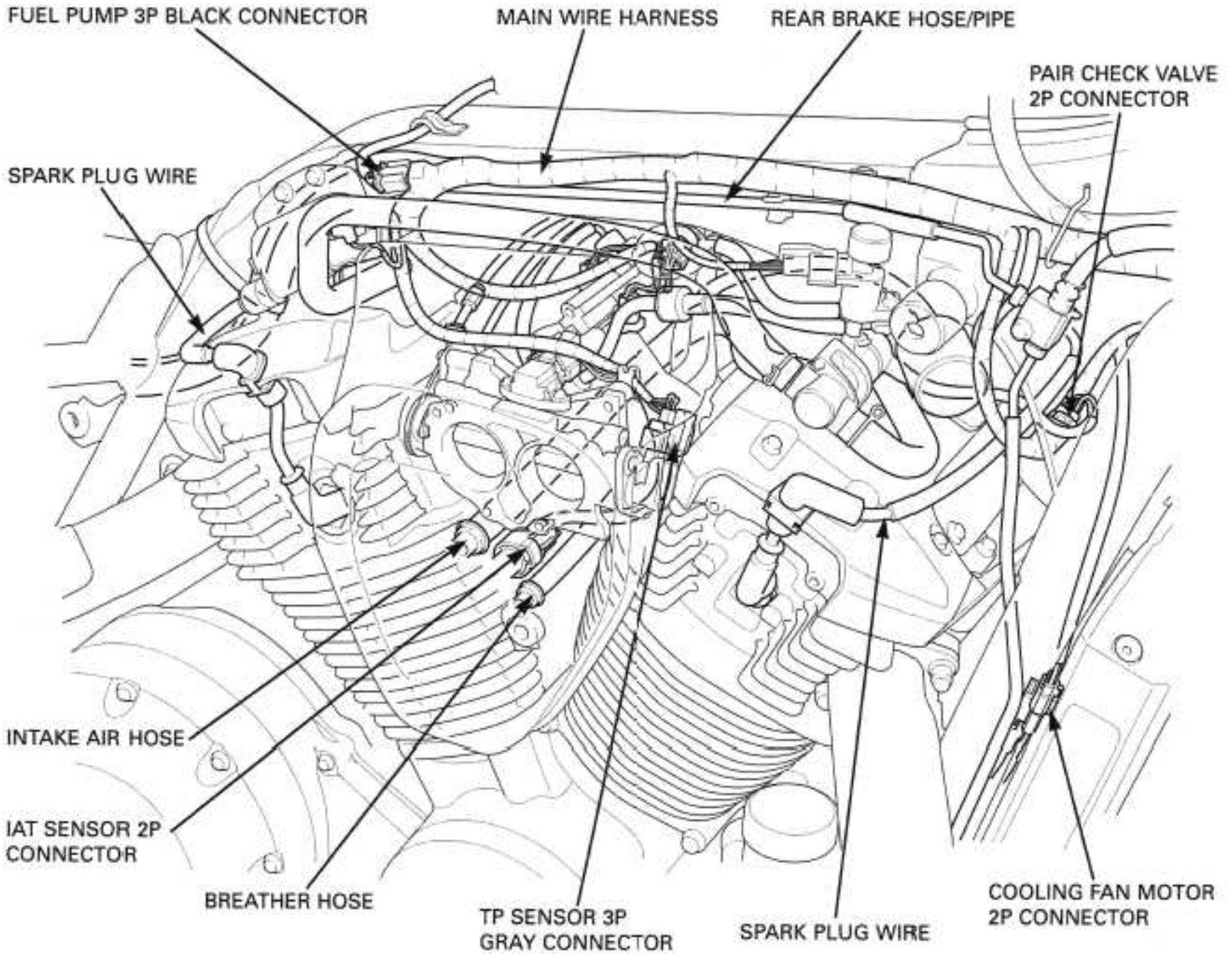

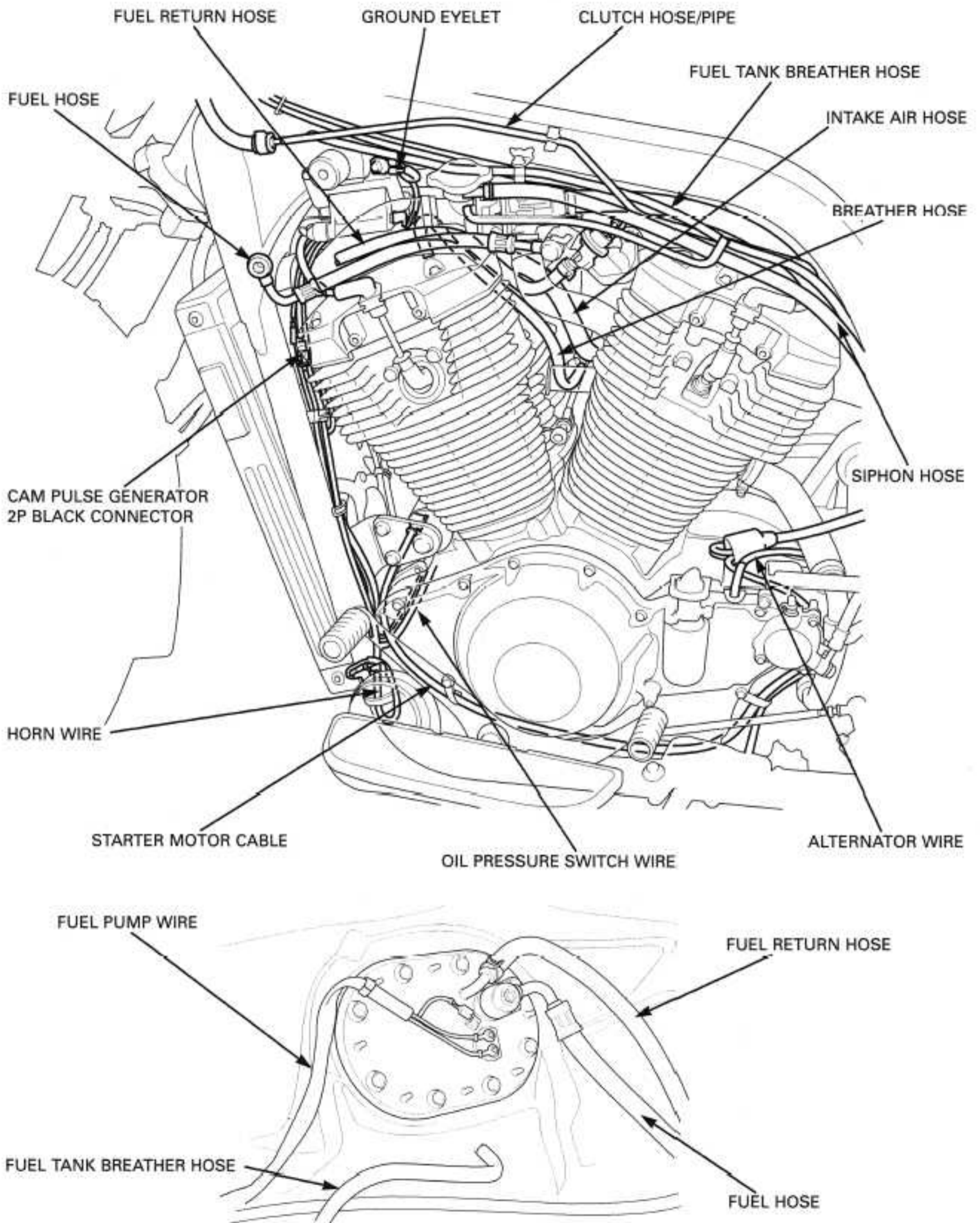



# GENERAL INFORMATION

---

- CONNECTOR BOOT:  
— IGNITION PULSE GENERATOR 2P  
— SIDE STAND SWITCH 2P GREEN  
— SPEED SENSOR 3P

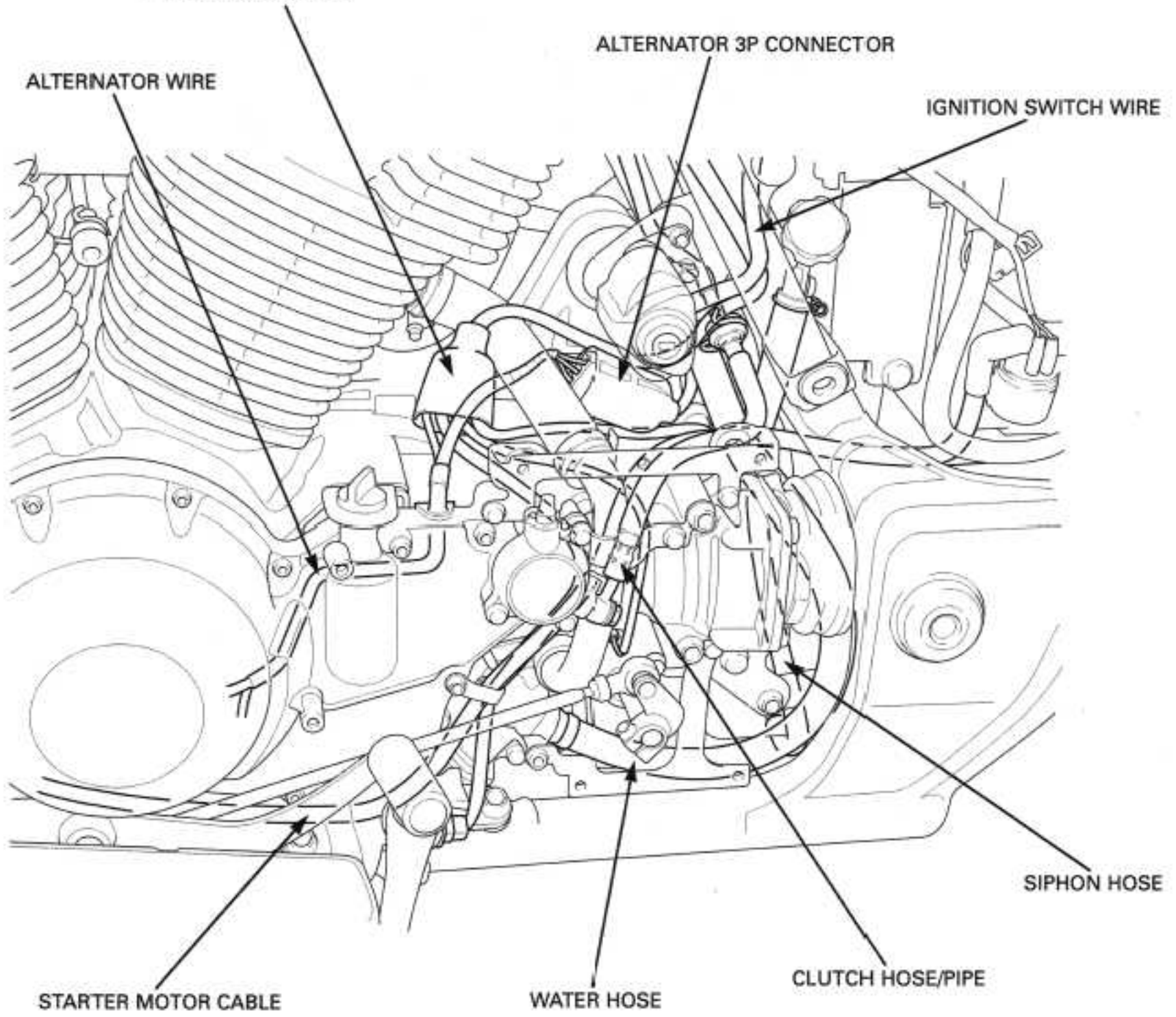



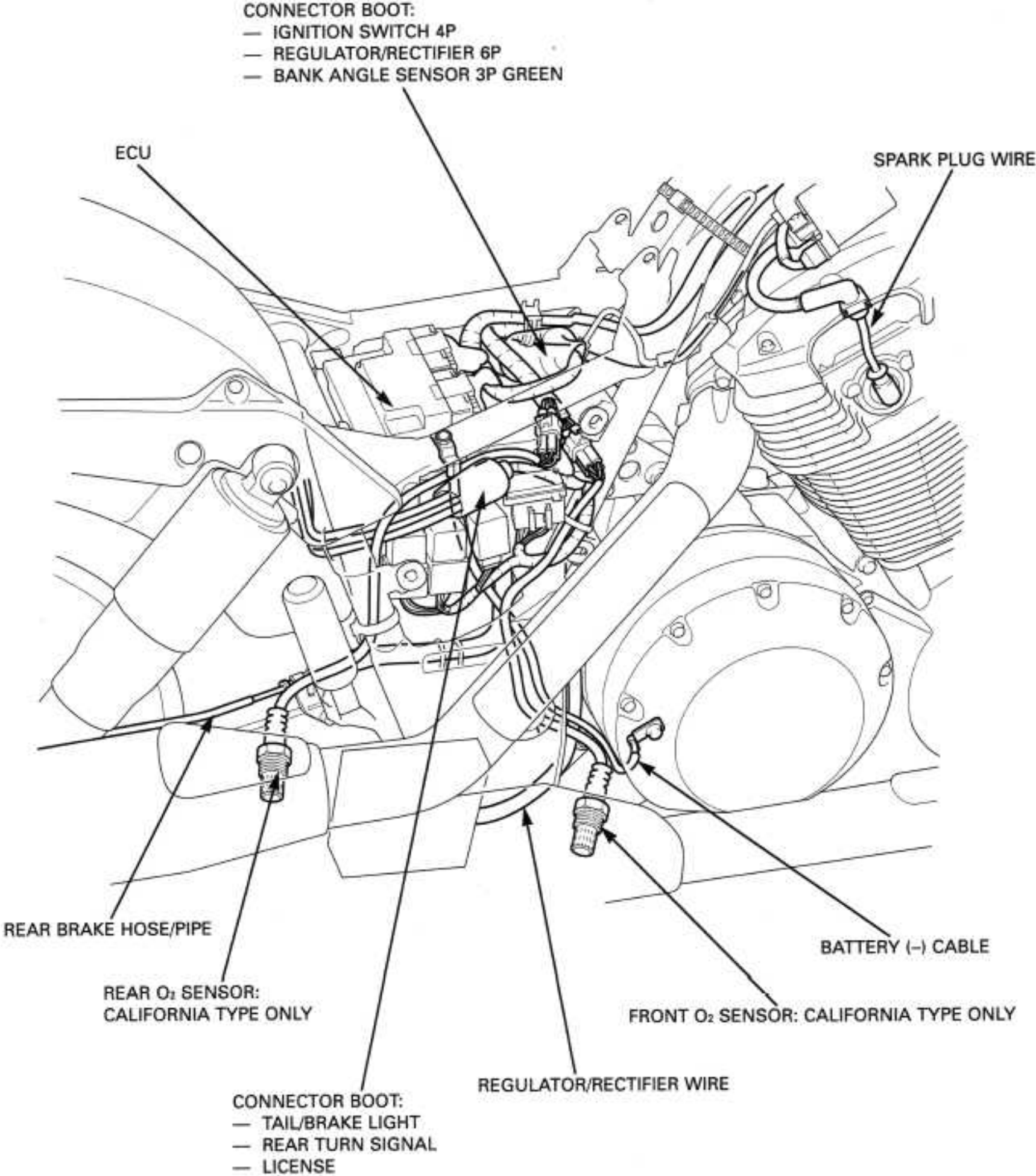

## GENERAL INFORMATION

### CONNECTOR BOOT:

- IGNITION SWITCH 4P
- REGULATOR/RECTIFIER 6P
- BANK ANGLE SENSOR 3P GREEN

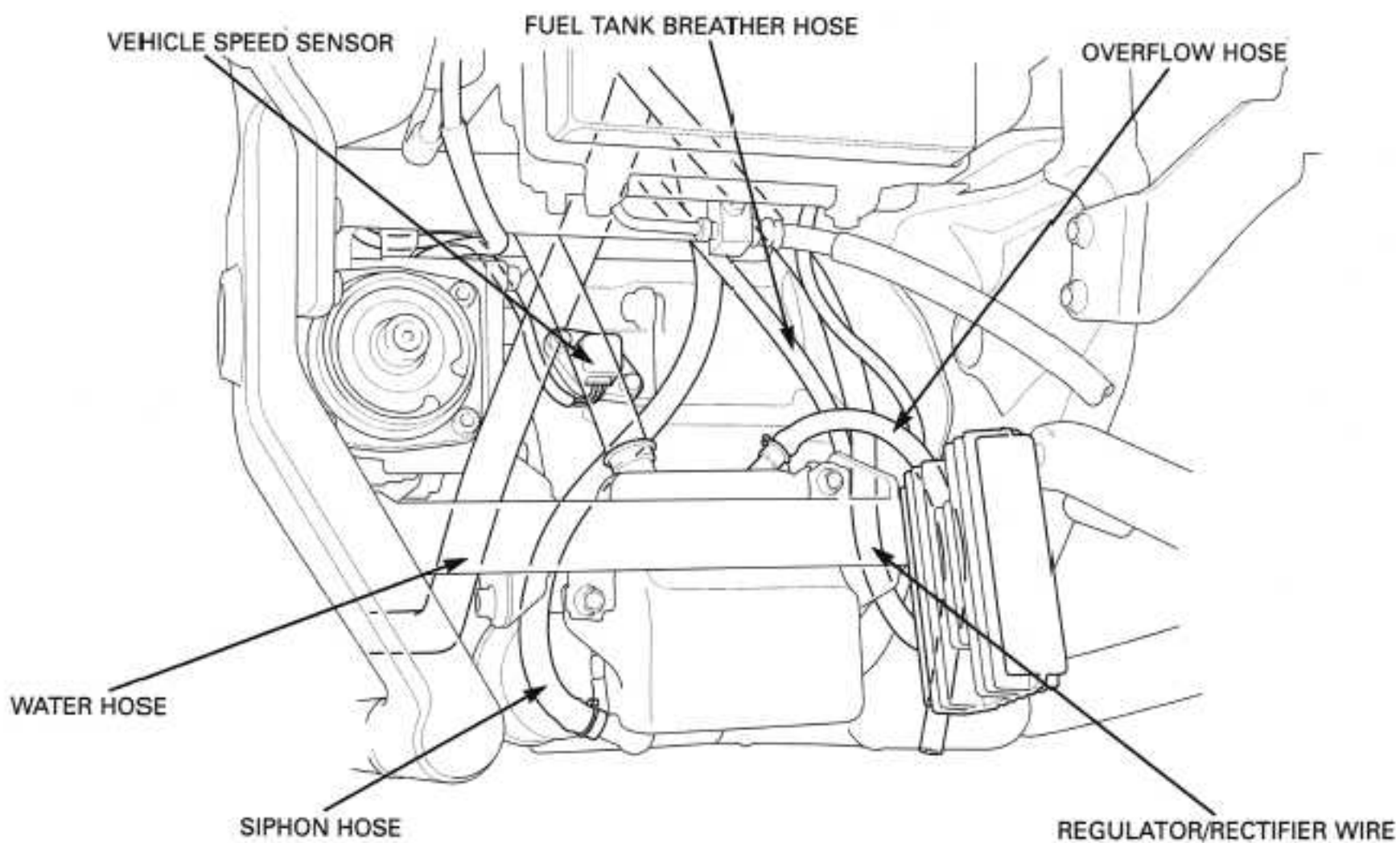
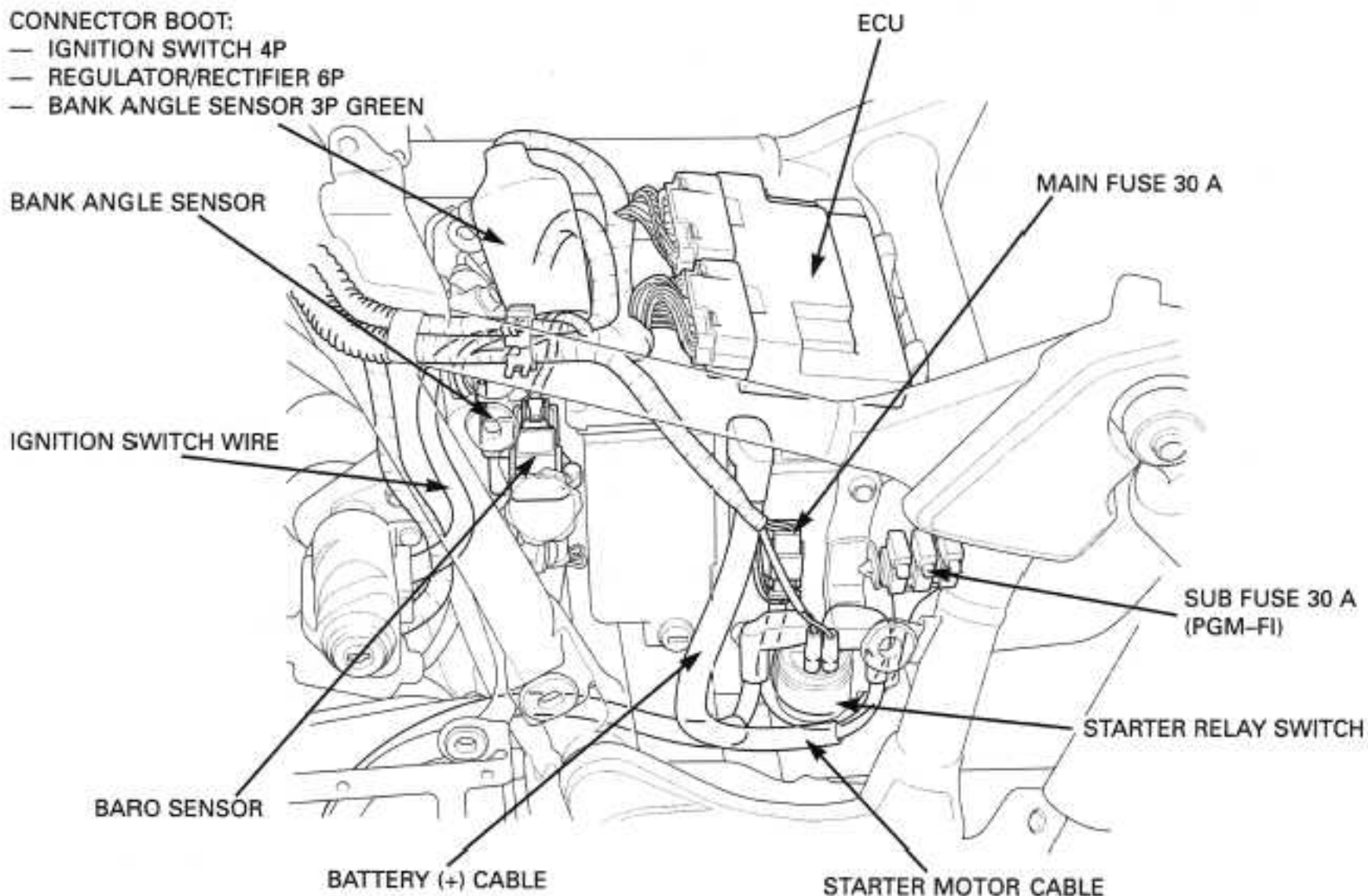

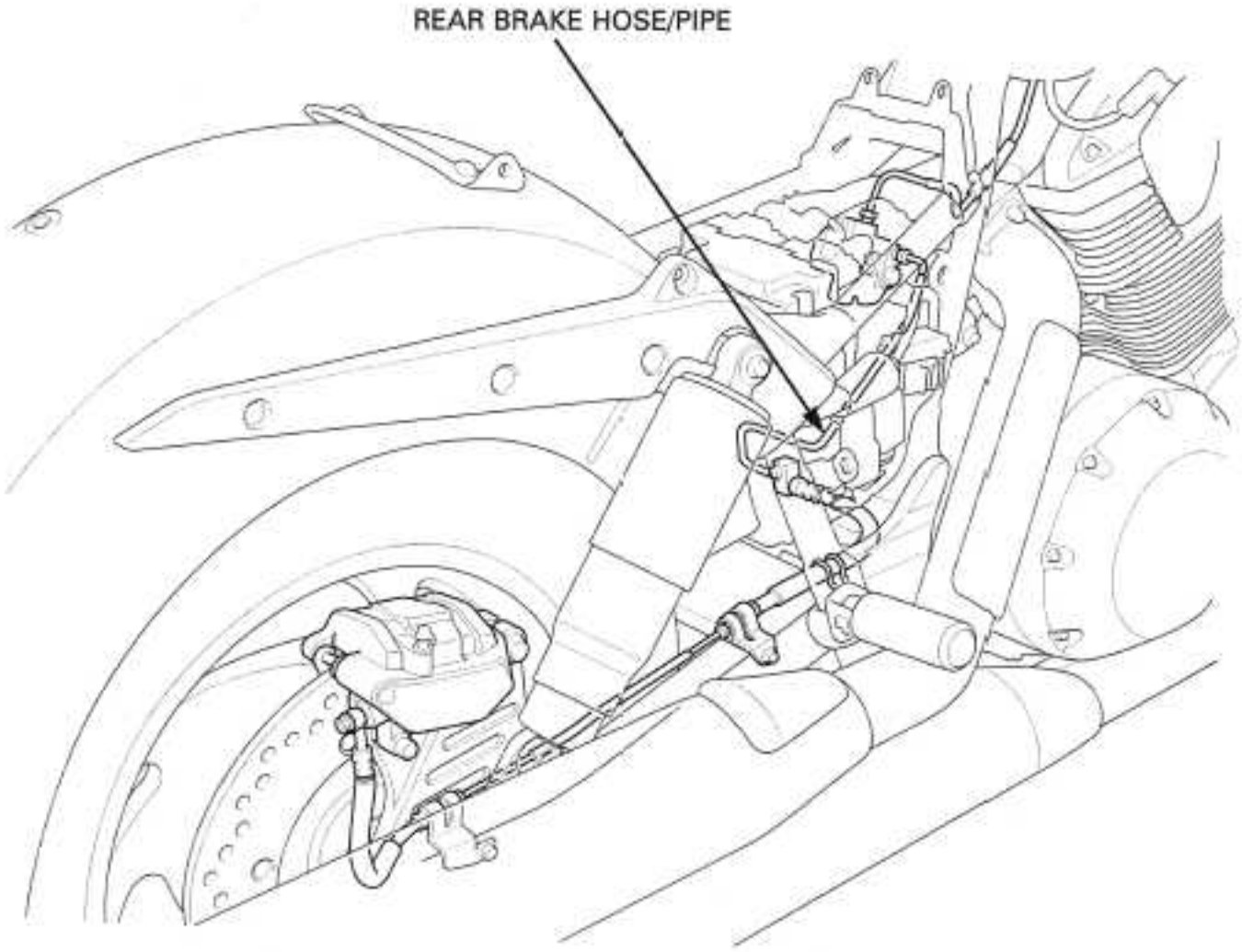
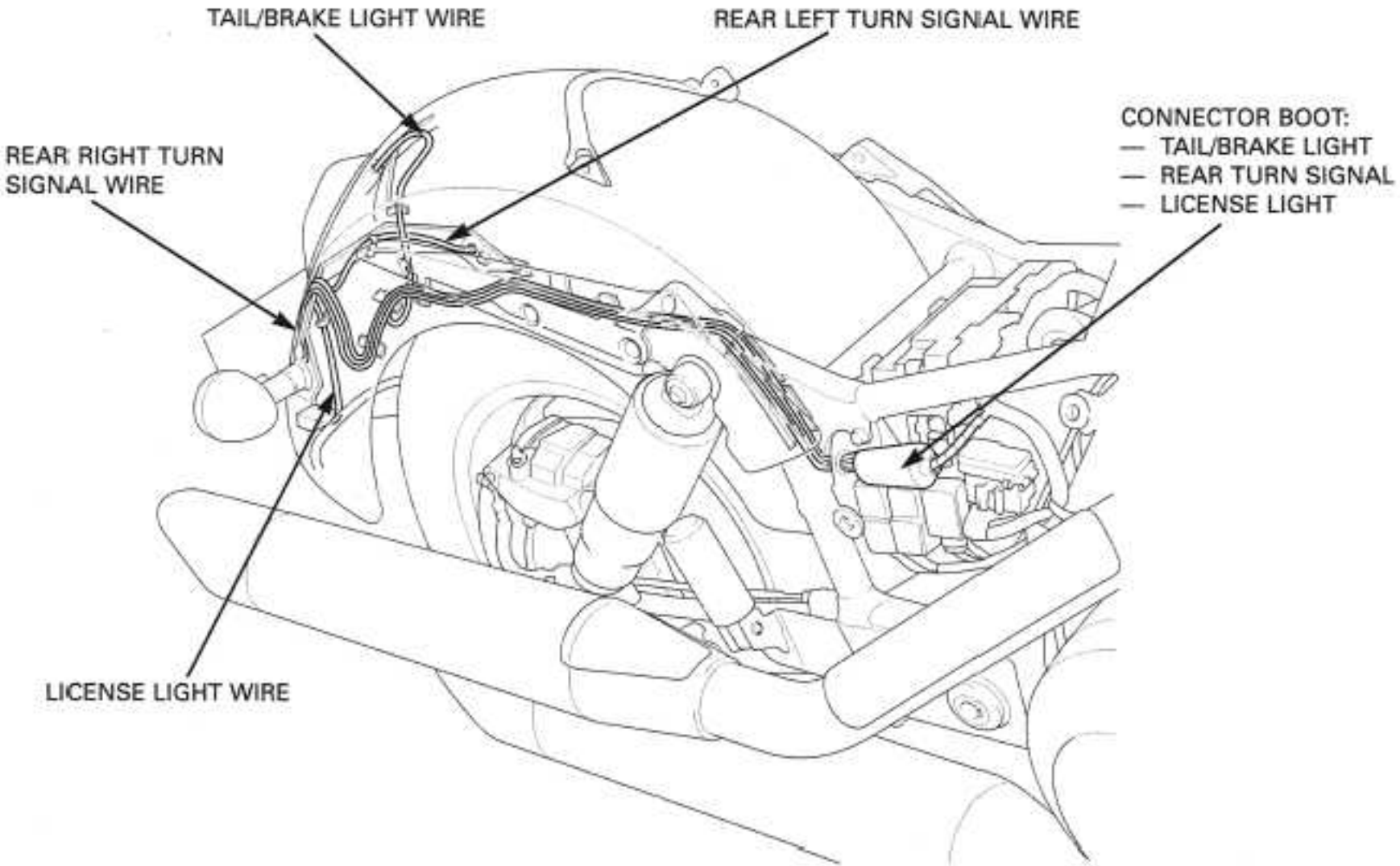

# GENERAL INFORMATION

## CALIFORNIA TYPE:

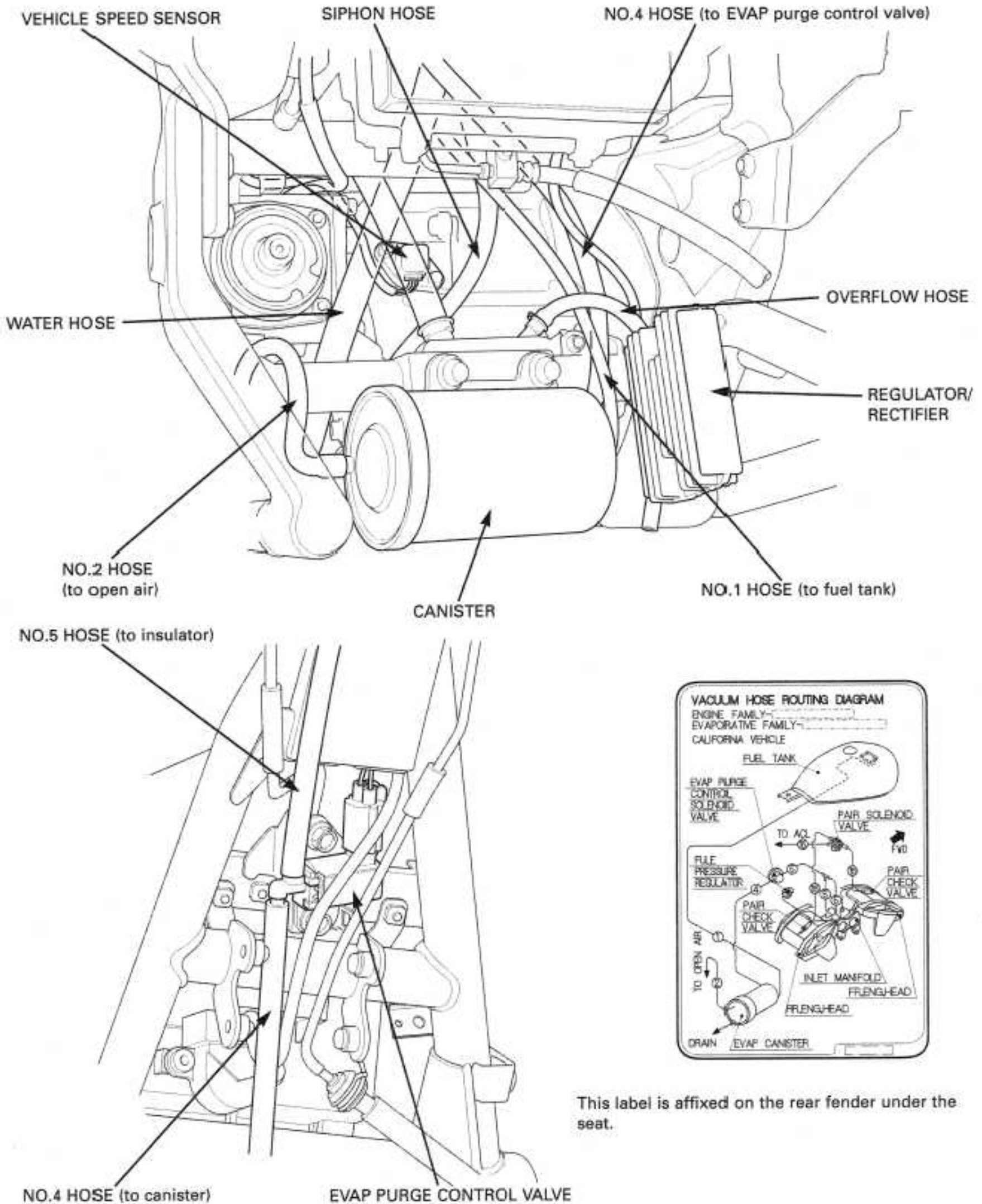

This label is affixed on the rear fender under the seat.



## EMISSION CONTROL SYSTEMS

The U.S. Environmental Protection Agency, California Air Resources Board (CARB) and Transport Canada require manufacturers to certify that their motorcycles comply with applicable exhaust emissions standards during their useful life, when operated and maintained according to the instructions provided, and that motorcycles built after January 1, 1983 comply with applicable noise emission standards for one year or 6,000 km (3,730 miles) after the time of sale to the ultimate purchaser, when operated and maintained according to the instructions provided. Compliance with the terms of the Distributor's Limited Warranty for Honda Motorcycle Emission Control Systems is necessary in order to keep the emissions system warranty in effect.

### SOURCE OF EMISSIONS

The combustion process produces carbon monoxide, oxides of nitrogen and hydrocarbons. Control of oxides of nitrogen and hydrocarbons is very important because, under certain conditions, they react to form photochemical smog when subjected to sunlight. Carbon monoxide does not react in the same way, but it is toxic.

Honda Motor Co., Ltd. utilizes lean injection settings as well as other systems, to reduce carbon monoxide and hydrocarbons.

### CRANKCASE EMISSION CONTROL SYSTEM

The engine is equipped with a closed crankcase system to prevent discharging crankcase emissions into the atmosphere. Blow-by gas is returned to the combustion chamber through the air cleaner and throttle body.

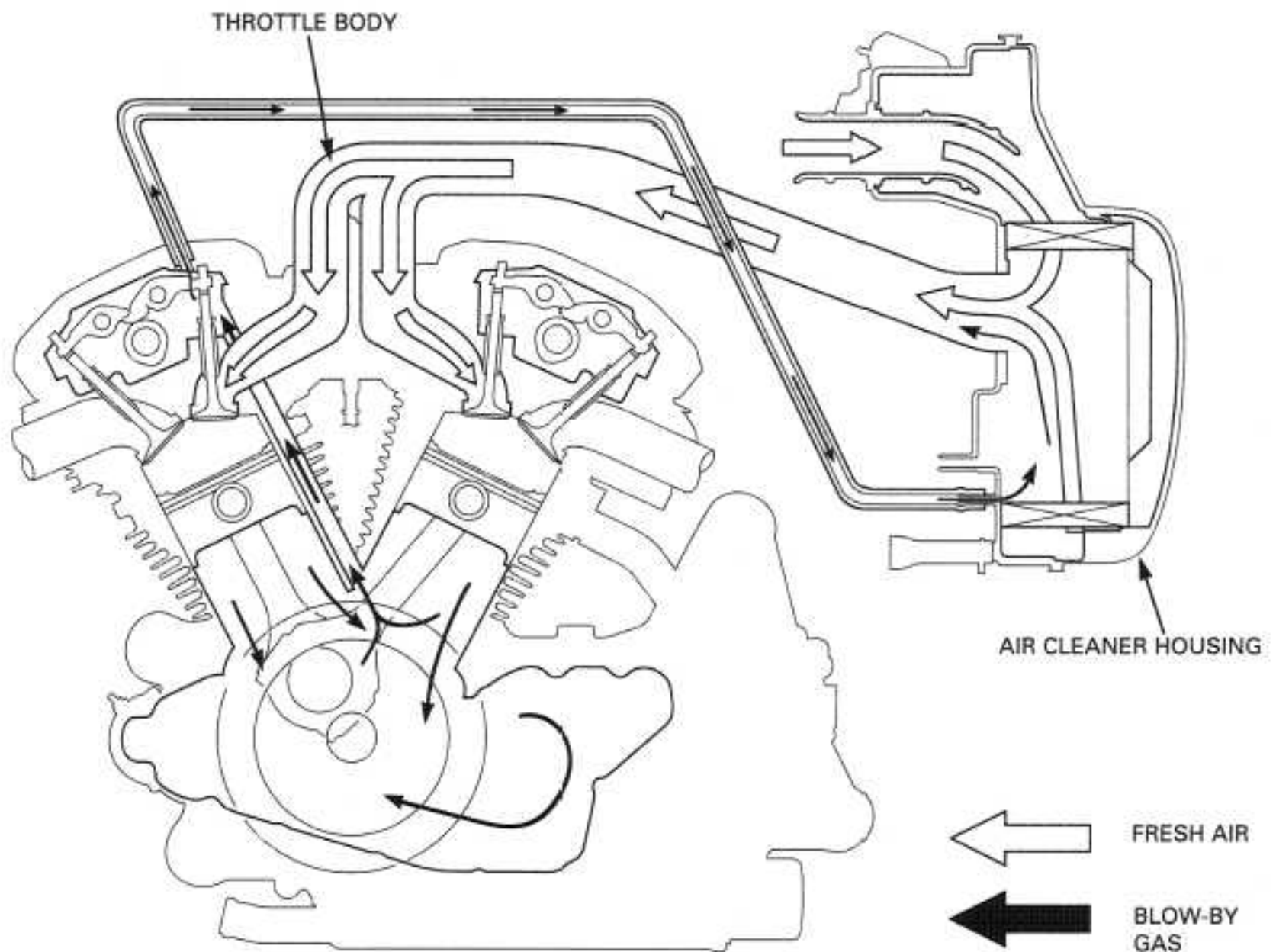



## GENERAL INFORMATION

### EXHAUST EMISSION CONTROL SYSTEM (SECONDARY AIR SUPPLY SYSTEM)

The exhaust emission control system is composed of a lean fuel injection setting, and no adjustments should be made except idle speed adjustment with the throttle stop screw. The exhaust emission control system is separate from the crankcase emission control system.

The exhaust emission control system consists of a secondary air supply system which introduces filtered air into the exhaust gases in the exhaust port. Fresh air is drawn into the exhaust port by the function of the PAIR (Pulse Secondary Air Injection) control valve.

This charge of fresh air promotes burning of the unburned exhaust gases and changes a considerable amount of hydrocarbons and carbon monoxide into relatively harmless carbon dioxide and water vapor.

The reed valve prevents reverse air flow through the system. The PAIR control valve is operated by the solenoid valve. The solenoid valve is controlled by the PGM-FI unit, and the fresh air passage is opened/closed according the running condition (ECT/IAT/TP/MAP sensor and engine revolution).

No adjustments to the secondary air supply system should be made, although periodic inspection of the components is recommended.

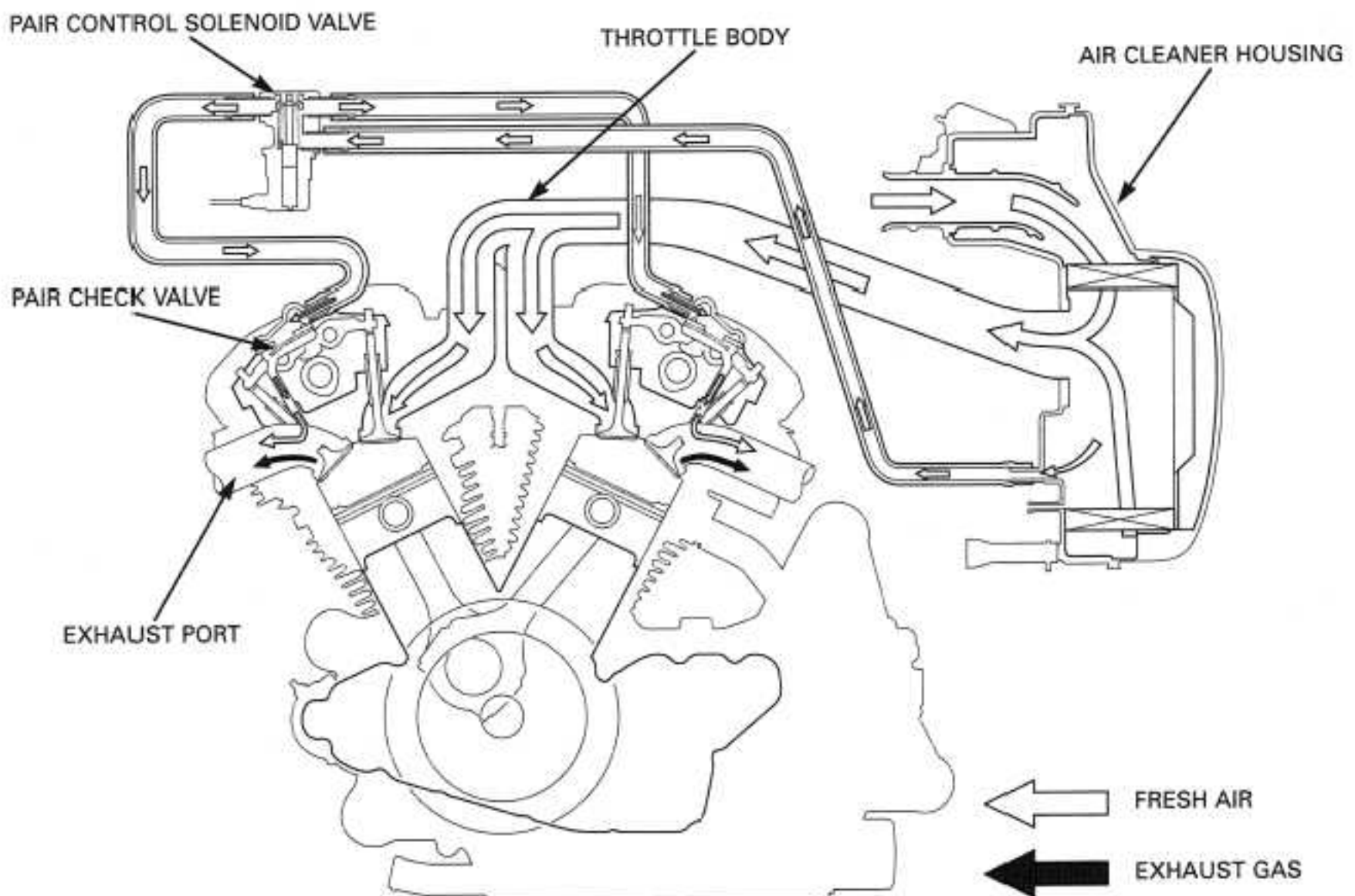

#### California type:

The California type is also equipped with a three-way catalytic converter, and a heated oxygen sensor.

The three-way catalytic converters are in the exhaust system. Through chemical reactions, they convert HC, CO, and NO<sub>x</sub> in the engine's exhaust to carbon dioxide (CO<sub>2</sub>), dinitrogen (N<sub>2</sub>), and water vapor.

No adjustment to these systems should be made although periodic inspection of the components is recommended.

## EVAPORATIVE EMISSION CONTROL SYSTEM (CALIFORNIA TYPE ONLY)

This model complies with CARB evaporative emission requirements.

Fuel vapor from the fuel tank is routed into the evaporative emission (EVAP) canister where it is absorbed and stored while the engine is stopped. When the engine is running and the evaporative emission (EVAP) purge control solenoid valve is open, fuel vapor in the EVAP canister is drawn into the engine through the throttle body.

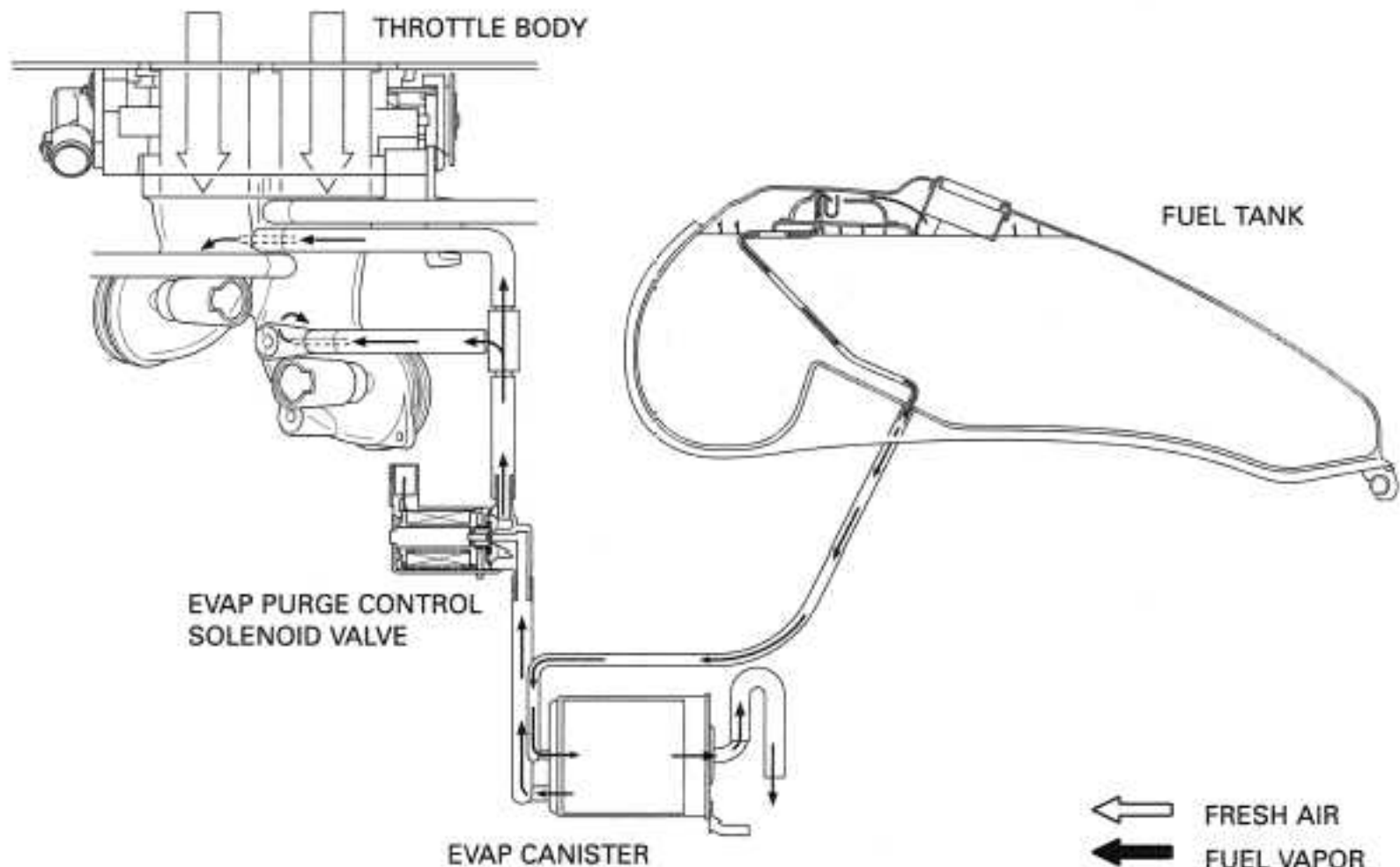

## NOISE EMISSION CONTROL SYSTEM

**TAMPERING WITH THE NOISE CONTROL SYSTEM IS PROHIBITED:** U.S. Federal law prohibits, or Canadian provincial law may prohibit the following acts or the causing there of: (1) The removal or rendering inoperative by any person, other than for the purposes of maintenance, repair or replacement, of any device or element of design incorporated into any vehicle for the purpose of noise control prior to its sale or delivery to the ultimate customer or while it is in use; or (2) the use of any vehicle after such device or element of design has been removed or rendered inoperative by any person.

**AMONG THOSE ACTS PRESUMED TO CONSTITUTE TAMPERING ARE THE ACTS LISTED BELOW:**

1. Removal of, or puncturing of the muffler, baffles, header pipes or any other component which conducts exhaust gases.
2. Removal of, or puncturing of any part of the intake system.
3. Lack of proper maintenance.
4. Replacing any moving parts of the vehicle, or parts of the exhaust or intake system, with parts other than those specified by the manufacturer.

## GENERAL INFORMATION

### EMISSION CONTROL INFORMATION LABELS (U.S.A. ONLY)

An Emission Control Information Label is located on the front of the rear fender as shown. The seat must be removed to read it. It gives base tune-up specifications.

EMISSION CONTROL INFORMATION LABEL

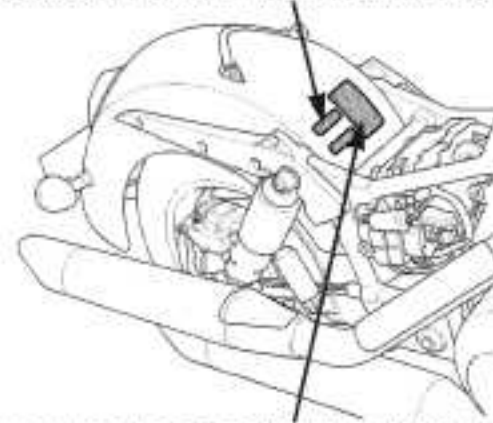

VACUUM HOSE ROUTING DIAGRAM LABEL

### VACUUM HOSE ROUTING DIAGRAM LABEL (CALIFORNIA TYPE ONLY)

The Vacuum Hose Routing Diagram Label is on the front of the rear fender as shown. The seat must be removed to read it.

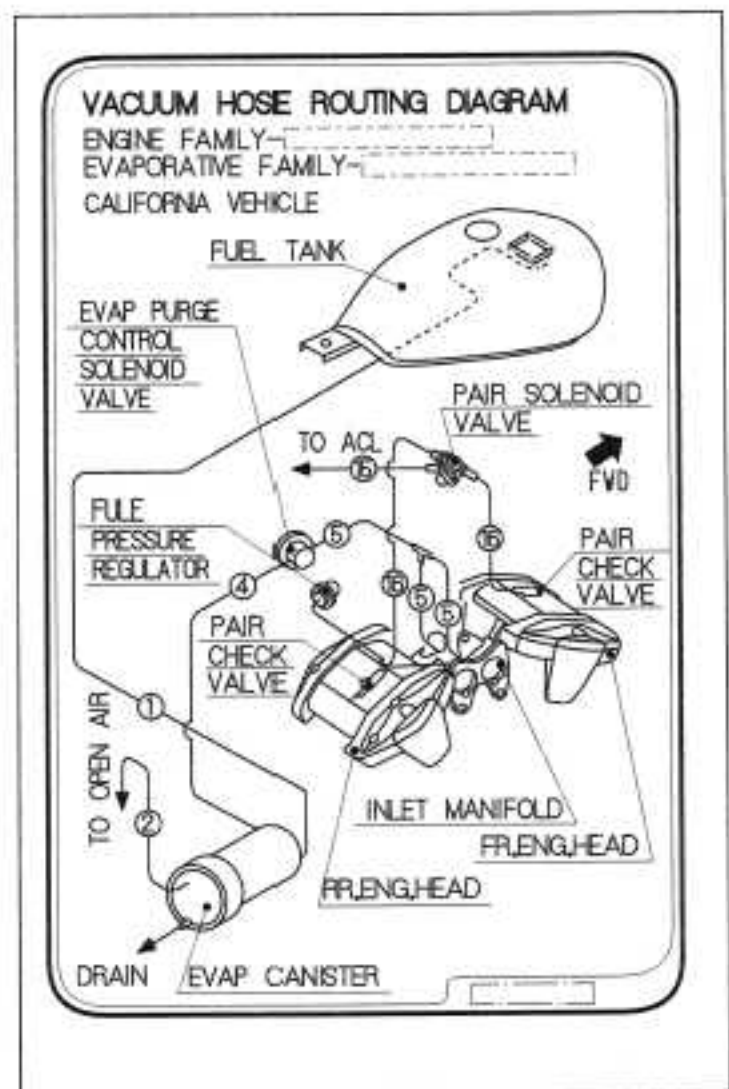

# 2. FRAME/BODY PANELS/EXHAUST SYSTEM

SERVICE INFORMATION	2-1	LEFT CRANKCASE REAR COVER	2-3
TROUBLESHOOTING	2-1	REAR FENDER	2-3
SEAT	2-2	MUFFLER/EXHAUST PIPE	2-4
SIDE COVER	2-2		

## SERVICE INFORMATION

### GENERAL

- Work in a well ventilated area. Smoking or allowing flames or sparks in the work area or where gasoline is stored can cause a fire or explosion.
- This section covers removal and installation of the body panels and exhaust system.
- Serious burns may result if the exhaust system is not allowed to cool before components are removed or serviced.
- Always replace the exhaust pipe gaskets after removing the exhaust pipe from the engine.
- When installing the exhaust system, loosely install all of the exhaust pipe fasteners. Always tighten the exhaust clamps first, then tighten the mounting fasteners. If you tighten the mounting fasteners first, the exhaust pipe may not seat properly.
- Always inspect the exhaust system for leaks after installation.

### TORQUE VALUES

Exhaust pipe joint nut	23 N•m (2.3 kgf•m, 17 lbf•ft)
Muffler band bolt	17 N•m (1.7 kgf•m, 12 lbf•ft)
Muffler stay nut	34 N•m (3.5 kgf•m, 25 lbf•ft)
O <sub>2</sub> sensor	24.5 N•m (2.5 kgf•m, 18 lbf•ft)

## TROUBLESHOOTING

### Excessive exhaust noise

- Broken exhaust system
- Exhaust gas leak

### Poor performance

- Deformed exhaust system
- Exhaust gas leak
- Clogged muffler

### SEAT

#### REMOVAL

Remove the rubber caps, socket bolts, collars and seat band.

Remove the rubber cap, socket bolt and pillion seat.

Remove the bolt caps, socket bolts.  
Slide the seat back and then off.

#### INSTALLATION

Align the seat hook with the fuel tank rear bracket and install the seat.

Install and tighten the socket bolts securely.  
Install the bolt caps.  
Install the pillion seat and the socket bolt.  
Install the seat band, collars, socket bolts.  
Tighten the pillion seat socket bolts securely.  
Install the rubber caps.

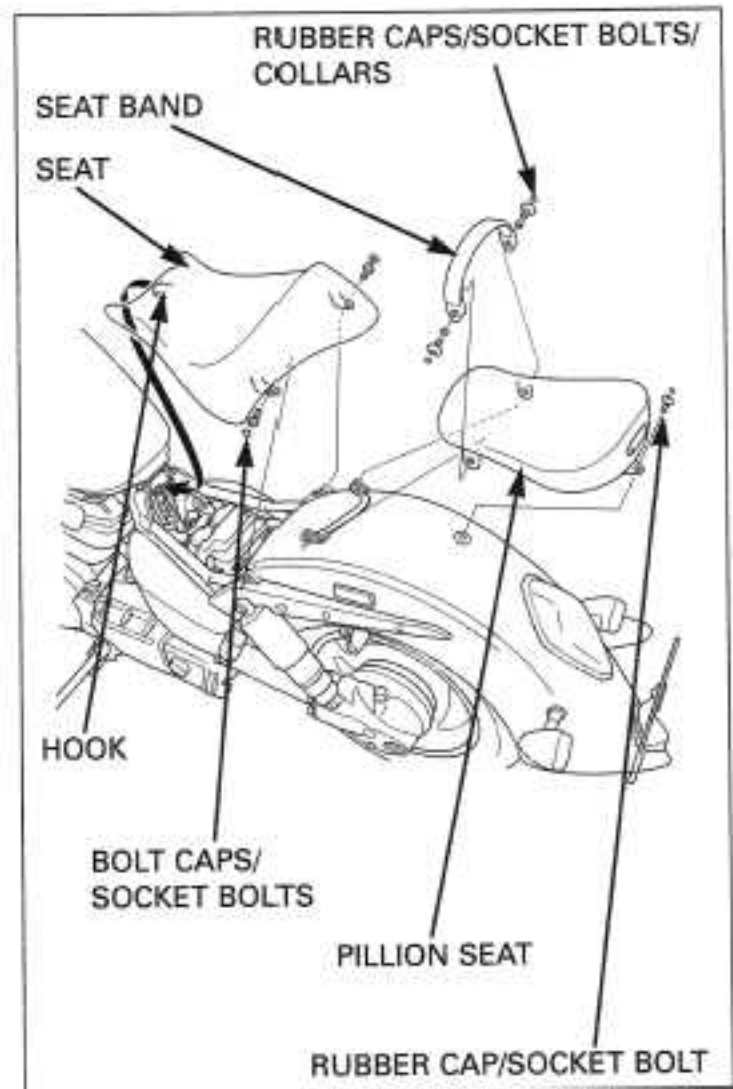

### SIDE COVER

#### RIGHT SIDE COVER

##### REMOVAL/INSTALLATION

*Be careful not to break or deform the side cover bosses.*

Release the right side cover bosses from the grommets.  
Remove the right side cover from the hook on the frame.

*Be careful not to dislodge the grommets in the frame.*

Installation is in the reverse order of removal.

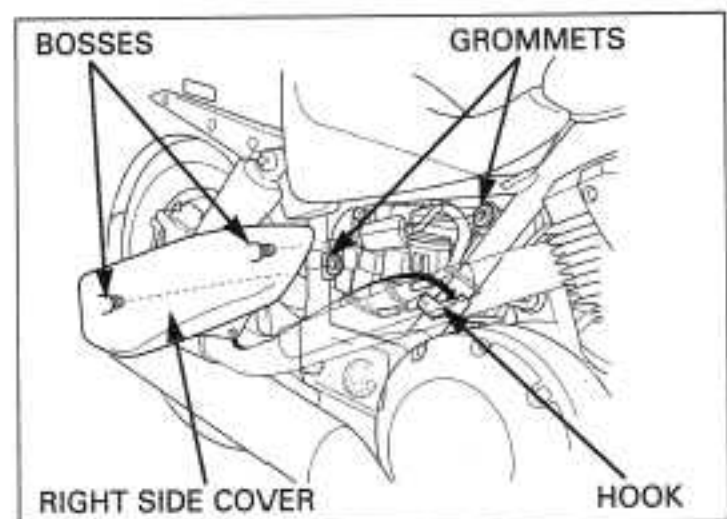

#### LEFT SIDE COVER

##### REMOVAL/INSTALLATION

*Be careful not to break or deform the side cover bosses.*

Release the left side cover bosses from the grommets and remove the left side cover.

*Be careful not to dislodge the grommets in the frame.*

Installation is in the reverse order of removal.

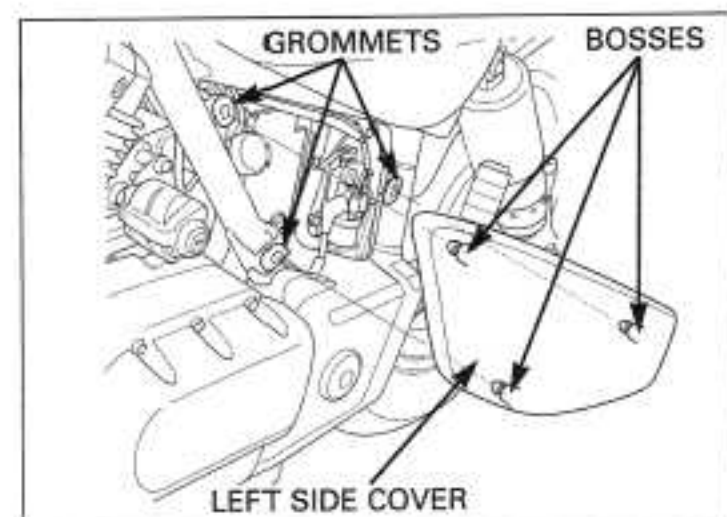



## LEFT CRANKCASE REAR COVER

### REMOVAL/INSTALLATION

Remove the socket bolts and left crankcase rear cover.

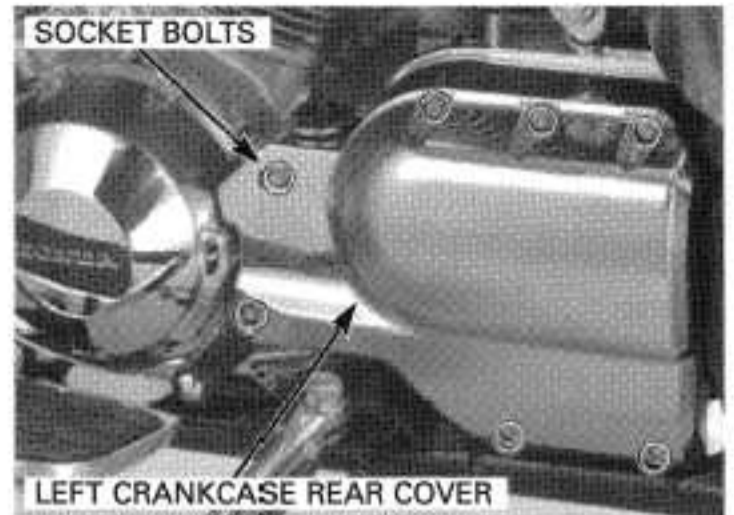

Remove the bolts and left crankcase rear cover stay.

Installation is in the reverse order of removal.



## REAR FENDER

### REMOVAL

Remove the right side cover (page 2-2).  
Remove the rear shock absorber (page 14-11).

Disconnect the tail/brake light connectors, license light connectors and rear turn signal connectors.

Remove the bolt caps, socket bolts, special bolts and the grab rail.

Remove the rear fender.

Installation is in the reverse order of removal.

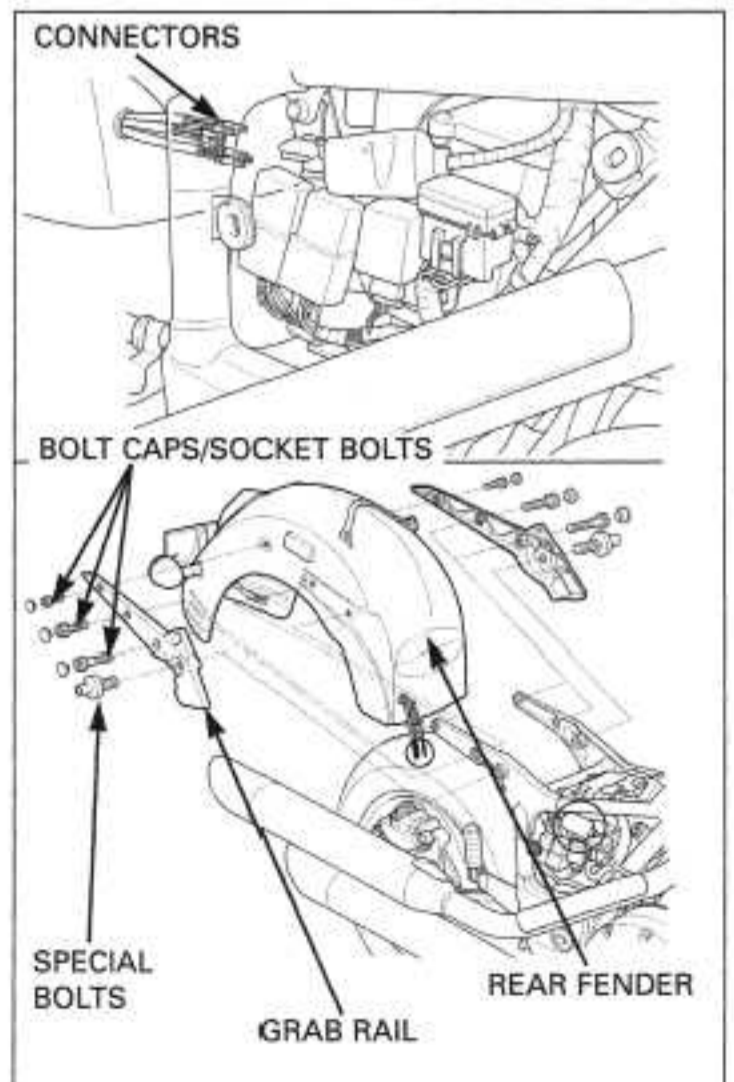

## MUFFLER/EXHAUST PIPE

### REMOVAL

Remove the left side cover (page 2-2).

*California type only:* Disconnect the front O<sub>2</sub> sensor 4P connector.  
Disconnect the rear O<sub>2</sub> sensor 4P black connector.

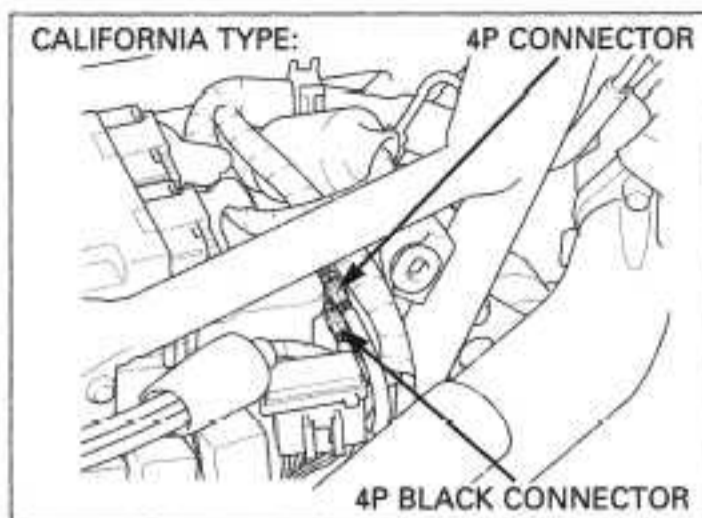

Remove the rear exhaust pipe joint nuts.  
Loosen the rear muffler band bolt.  
Remove the bolts and rear exhaust pipe/muffler assembly.  
Remove the gasket.  
Remove the front exhaust pipe joint nuts.  
Loosen the front muffler band bolt.  
Remove the nuts, washers and bolts.  
Remove the front exhaust pipe/muffler assembly.  
Remove the gasket.

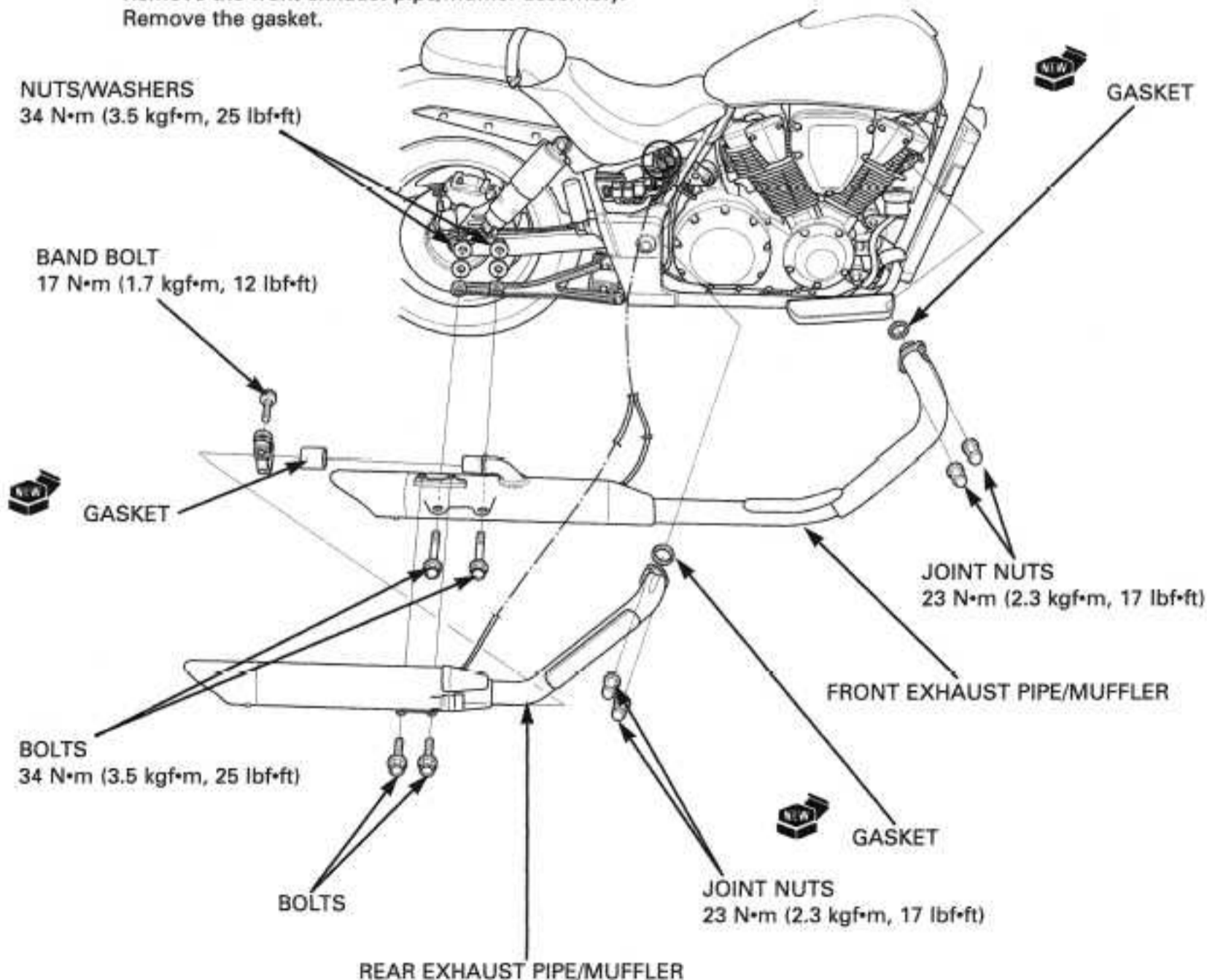

## INSTALLATION

It is important to follow the tightening order.

- If the exhaust system will not be disassembled, steps 1 and 2 are not necessary.

Refer to the illustration:

1. Before mounting the exhaust system, assemble the front and rear exhaust pipe by temporarily tightening the exhaust pipe band bolt (1).
2. Temporarily tighten the muffler band bolt (2).
3. Make sure the new gaskets are installed in the correct position.  
Insert the exhaust flange into the cylinder head studs and loosely install the exhaust pipe joint nuts (3)/(4).
4. Hold the exhaust pipe/muffler assembly and loosely install the mounting bolts and nuts (5).  
After mounting the exhaust system, tighten each fastener in the sequence below.
5. Tighten the muffler band bolt (2) to the specified torque.

**TORQUE: 17 N·m (1.7 kgf·m, 12 lbf·ft)**

6. Tighten the exhaust pipe band bolt (1) to the specified torque.

**TORQUE: 17 N·m (1.7 kgf·m, 12 lbf·ft)**

7. Tighten each pair of exhaust pipe joint nuts (3)/(4) alternately in two or three steps to the specified torque.

**TORQUE: 23 N·m (2.3 kgf·m, 17 lbf·ft)**

8. Tighten the mounting nuts (5) to the specified torque.

**TORQUE: 34 N·m (3.5 kgf·m, 25 lbf·ft)**

Tighten the exhaust pipe cover bolts if the exhaust cover was removed (see the following page).

After installation, inspect the exhaust system for leaks.

Tightening procedure:

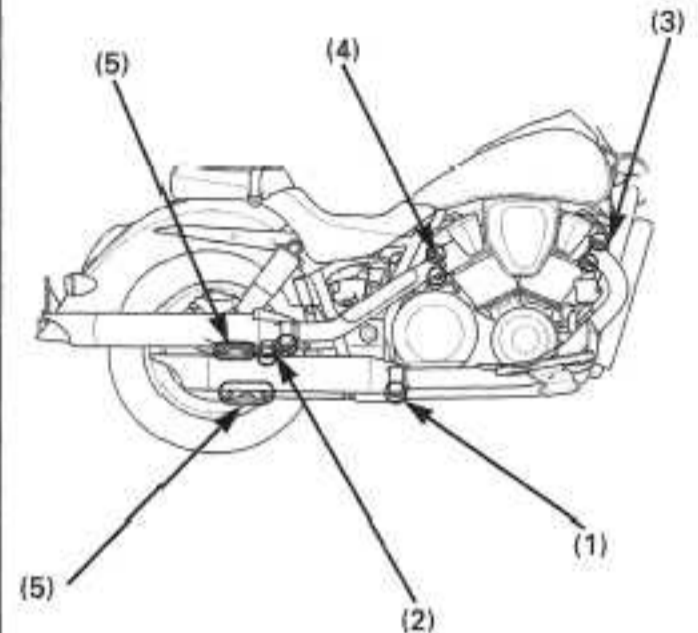

## DISASSEMBLY/ASSEMBLY

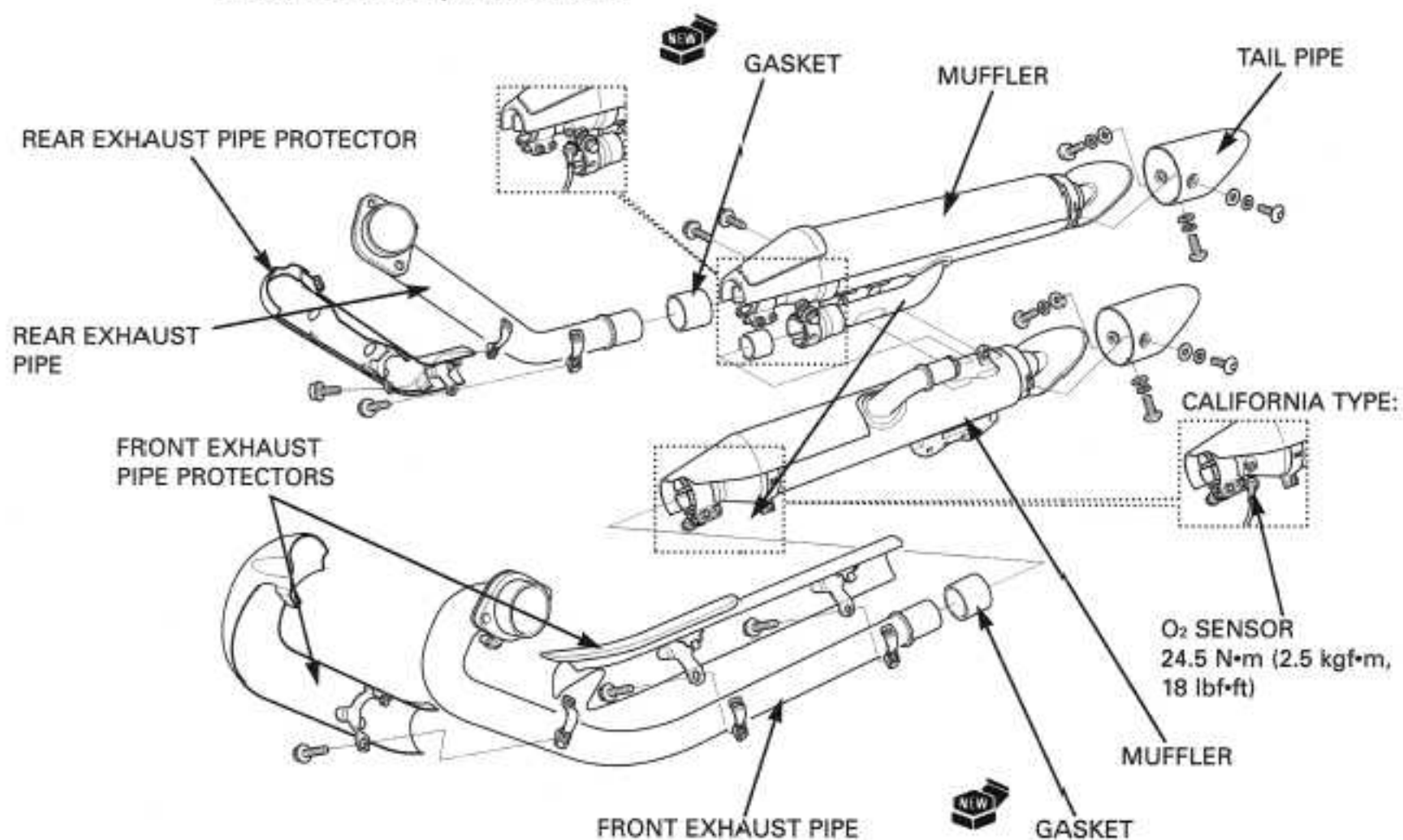

- If the front and rear exhaust pipe covers were removed, temporarily install the exhaust pipe covers when installing the exhaust system onto the engine and tighten the cover band bolts after installing the exhaust system.

Install the exhaust pipe cover by aligning the holders with the tabs of the flange retainer.

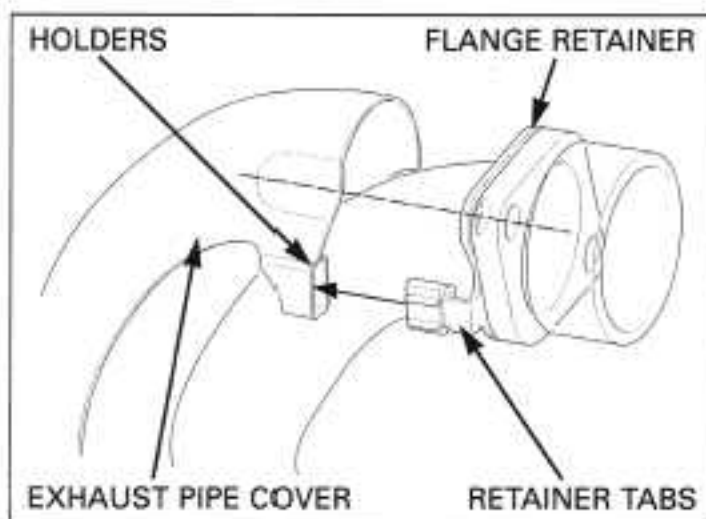

# 3. MAINTENANCE

SERVICE INFORMATION	3-1	FINAL DRIVE OIL	3-17
MAINTENANCE SCHEDULE	3-3	BRAKE FLUID	3-18
FUEL LINE	3-4	BRAKE PAD WEAR	3-19
THROTTLE OPERATION	3-4	BRAKE SYSTEM	3-19
AIR CLEANER	3-5	BRAKE LIGHT SWITCH	3-20
CRANKCASE BREATHER	3-6	HEADLIGHT AIM	3-20
SPARK PLUG	3-6	CLUTCH SYSTEM	3-21
VALVE CLEARANCE	3-8	CLUTCH FLUID	3-21
ENGINE OIL/OIL FILTER	3-12	SIDE STAND	3-21
ENGINE IDLE SPEED	3-15	SUSPENSION	3-22
RADIATOR COOLANT	3-15	NUTS, BOLTS, FASTENERS	3-22
COOLING SYSTEM	3-15	WHEELS/TIRES	3-23
SECONDARY AIR SUPPLY SYSTEM	3-16	STEERING HEAD BEARINGS	3-23
EVAPORATIVE EMISSION CONTROL SYSTEM (CALIFORNIA TYPE ONLY)	3-17		

3

## SERVICE INFORMATION

### GENERAL

- Place the motorcycle on level ground before starting any work.
- Gasoline is extremely flammable and is explosive under certain conditions.
- Work in a well ventilated area. Smoking or allowing flames or sparks in the work area or where the gasoline is stored can cause a fire or explosion.
- If the engine must be running to do some work, make sure the area is well ventilated. Never run the engine in an enclosed area.
- The exhaust contains poisonous carbon monoxide gas that may cause loss of consciousness and may lead to death. Run the engine in an open area or with an exhaust evacuation system in an enclosed area.



## MAINTENANCE

### SPECIFICATIONS

ITEM		SPECIFICATIONS	
Throttle grip free play		2 – 6 mm (1/16 – 1/4 in)	
Spark plug	NGK	IFR5L11, IFR6L11, IFR7L11	
	DENSO	VK16PRZ11, VK20PRZ11, VK22PRZ11	
Spark plug gap		1.0 – 1.1 mm (0.039 – 0.043 in)	
Valve clearance	IN	0.13 ± 0.02 mm (0.005 ± 0.001 in)	
	EX	0.32 ± 0.02 mm (0.013 ± 0.001 in)	
Engine oil capacity	After draining	3.5 liter (3.7 US qt, 3.1 Imp qt)	
	After draining/oil filter change	3.7 liter (3.9 US qt, 3.3 Imp qt)	
Recommended engine oil		Pro Honda GN4 or HP4 4-stroke oil (U.S.A. and Canada), or Honda 4-stroke oil (Canada only), or equivalent motor oil API service classification SF or SG Viscosity: SAE 10W-40	
Engine idle speed		800 ± 100 rpm	
Recommended brake fluid		DOT 4	
Tire size	Front	150/80R17M/C 72H	
	Rear	180/70R16M/C 77H	
Tire brand	Dunlop	Front	D251F
		Rear	D251
Tire air pressure	Up to 90 kg (200 lb) load	Front	225 kPa (2.25 kgf/cm <sup>2</sup> , 33 psi)
		Rear	225 kPa (2.25 kgf/cm <sup>2</sup> , 33 psi)
	Up to maximum weight capacity	Front	225 kPa (2.25 kgf/cm <sup>2</sup> , 33 psi)
		Rear	250 kPa (2.50 kgf/cm <sup>2</sup> , 36 psi)
Minimum tire tread depth	Front	1.5 mm (0.06 in)	
	Rear	2.0 mm (0.08 in)	

### TORQUE VALUES

Air cleaner housing cover bolt	3.4 N•m (0.35 kgf•m, 2.5 lbf•ft)
Fuel tank rear mounting bolt	12 N•m (1.2 kgf•m, 9 lbf•ft) U-nut.
Spark plug	18 N•m (1.8 kgf•m, 13 lbf•ft)
Valve adjusting screw lock nut	22 N•m (2.2 kgf•m, 16 lbf•ft)
Timing hole cap	18 N•m (1.8 kgf•m, 13 lbf•ft) Apply grease to the threads.
Front oil drain bolt	29 N•m (3.0 kgf•m, 22 lbf•ft)
Rear oil drain bolt	29 N•m (3.0 kgf•m, 22 lbf•ft)
Oil filter cartridge	26 N•m (2.7 kgf•m, 20 lbf•ft) Apply oil to the threads and flange surface.
Final drive oil filler cap	12 N•m (1.2 kgf•m, 9 lbf•ft)
Final drive oil drain bolt	20 N•m (2.0 kgf•m, 14 lbf•ft)

### TOOLS

Oil filter wrench	07HAA-PJ70101 or 07HAA-PJ70100
Valve adjusting screw wrench, 4 mm	07908-KE90100

# MAINTENANCE SCHEDULE

Perform the Pre-ride inspection in the Owner's Manual at each scheduled maintenance period.

I: Inspect and clean, adjust, lubricate or replace if necessary. C: Clean. R: Replace. A: Adjust. L: Lubricate.

The following items require some mechanical knowledge. Certain items (particularly those marked \* and \*\*) may require more technical information and tools. Consult your authorized Honda dealer.

ITEMS	FREQUENCY	NOTE ↓	ODOMETER READING (NOTE 1)								REFER TO PAGE	
			X1,000 mi	0.6	4	8	12	16	20	24		
			X1,000 km	1.0	6.4	12.8	19.2	25.6	32.0	38.4		
EMISSION RELATED ITEMS	* FUEL LINE					I		I		I	3-4	
	* THROTTLE OPERATION					I		I		I	3-4	
	AIR CLEANER	NOTE 2					R			R	3-5	
	CRANKCASE BREATHER	NOTE 3			C	C	C	C	C	C	3-6	
	SPARK PLUG				R		R		R		3-6	
	* VALVE CLEARANCE				I		I		I		3-8	
	ENGINE OIL			R		R		R			3-12	
	ENGINE OIL FILTER			R		R		R			3-12	
	* ENGINE IDLE SPEED				I	I	I	I	I	I	3-15	
	RADIATOR COOLANT	NOTE 5				I		I		R	3-15	
	* COOLING SYSTEM					I		I		I	3-15	
	* SECONDARY AIR SUPPLY SYSTEM					I		I		I	3-16	
	* EVAPORATIVE EMISSION CONTROL SYSTEM	NOTE 4					I			I	3-17	
NON-EMISSION RELATED ITEMS	FINAL DRIVE OIL					I		I		R	3-17	
	BRAKE FLUID	NOTE 5				I	I	R	I	I	R	3-18
	BRAKE PADS WEAR					I	I	I	I	I	3-19	
	BRAKE SYSTEM					I		I		I	3-19	
	* BRAKE LIGHT SWITCH					I		I		I	3-20	
	* HEADLIGHT AIM					I		I		I	3-20	
	CLUTCH SYSTEM					I		I		I	3-21	
	CLUTCH FLUID	NOTE 5			I	I	R	I	I	R	3-21	
	SIDE STAND					I		I		I	3-21	
	* SUSPENSION					I		I		I	3-22	
	* NUTS, BOLTS, FASTENERS					I		I		I	3-22	
	** WHEELS/TIRES					I		I		I	3-23	
	** STEERING HEAD BEARINGS					I		I		I	3-23	

- \* Should be serviced by an authorized Honda dealer, unless the owner has proper tools and service data and is mechanically qualified.
- \*\* In the interest of safety, we recommend these items be serviced only by your Honda dealer.

- NOTES:
1. At higher odometer readings, repeat at the frequency interval established here.
  2. Service more frequently if the motorcycle is ridden in unusually wet or dusty areas.
  3. Service more frequently when riding in rain or at full throttle.
  4. California type only.
  5. Replace every 2 years, or at indicated odometer interval, whichever comes first. Replacement requires mechanical skill.

### FUEL LINE

Remove the indicator box (page 19-7).

Remove the fuel tank mounting bolt and nut.

Slide the fuel tank back so the hooks on the fuel tank slide off the grommets on the frame.

Remove the grommets from the tabs on the frame.

Install the hooks on the fuel tank to the tabs on the frame.

Lift the fuel tank and support the rear end using a support that is approximately 200 mm long.

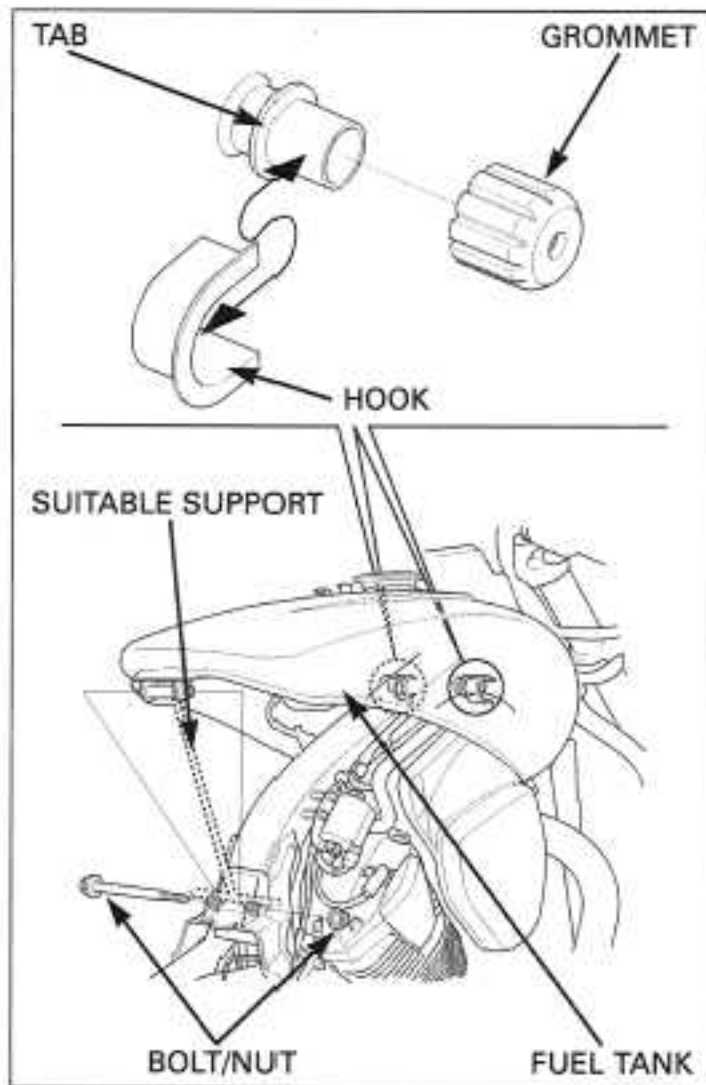

Check the fuel lines for deterioration, damage or leakage. Replace the fuel line if necessary.

Install the fuel tank in the reverse order of removal.

**TORQUE: Fuel tank rear mounting bolt:**  
12 N·m (1.2 kgf·m, 9 lbf·ft)

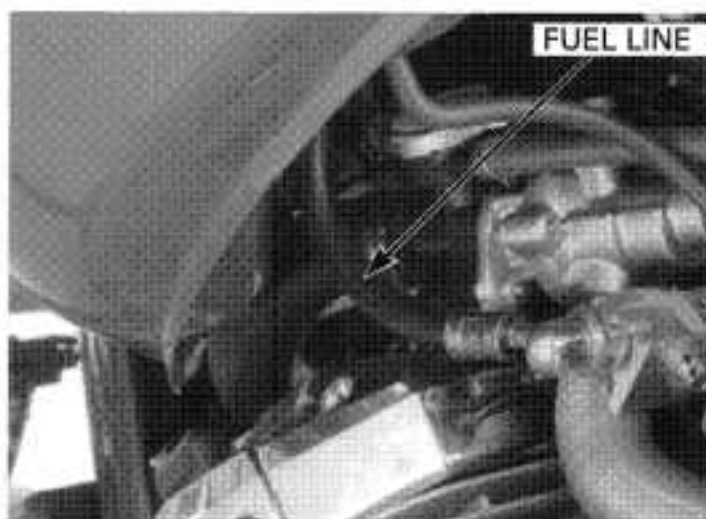

### THROTTLE OPERATION

Check for smooth throttle grip full opening and automatic full closing in all steering positions.

Check the throttle cables and replace them if they are deteriorated, kinked or damaged.

Lubricate the throttle cables if throttle operation is not smooth.

With the engine idling, turn the handlebar all the way to the right and left to ensure that the idle speed does not change.

If the idle speed increases, check the throttle grip free play and the throttle cable connection.

Measure the free play at the throttle grip flange.

**FREE PLAY: 2 - 6 mm (1/16 - 1/4 in)**

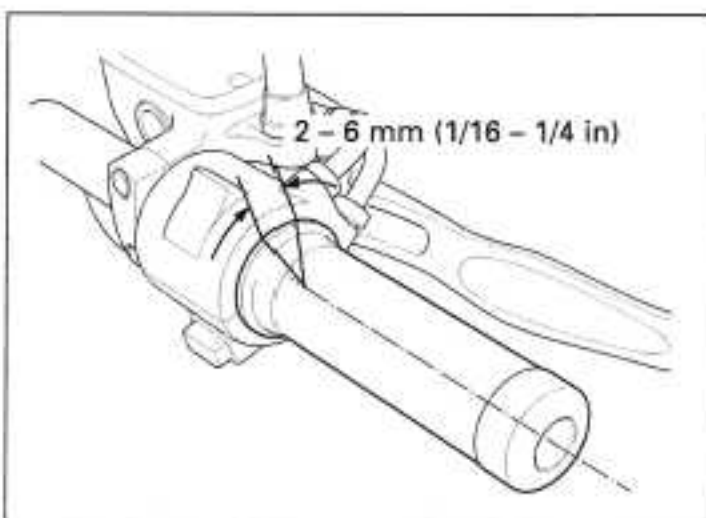

Throttle grip free play can be adjusted at either end of the throttle cable.

Minor adjustments are made with the upper adjuster. Adjust the free play by loosening the lock nut and turning the adjuster.

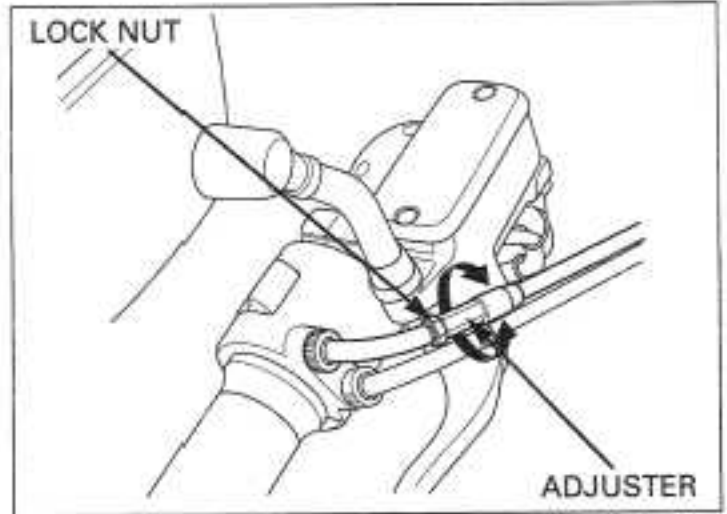

Major adjustments are made with the lower adjuster.

Remove the air cleaner housing (page 5-57).

Adjust the free play by loosening the lock nut and turning the adjuster. After adjustment, tighten the lock nut securely. Recheck the throttle operation. Replace any damaged parts, if necessary.

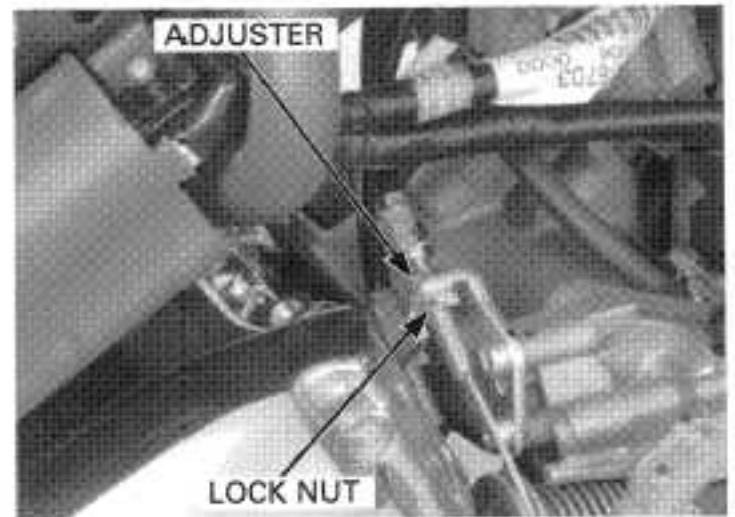

## AIR CLEANER

Remove the bolts, plastic washers and air cleaner housing cover.

Remove and discard the air cleaner element in accordance with the maintenance schedule (page 3-3). Also replace the air cleaner element anytime it is excessively dirty or damaged.

*At installation, be careful not to forget the plastic washers.*

Install the removed parts in the reverse order of removal.

**TORQUE: Air cleaner housing cover bolt:**  
3.4 N·m (0.35 kgf·m, 2.5 lbf·ft)

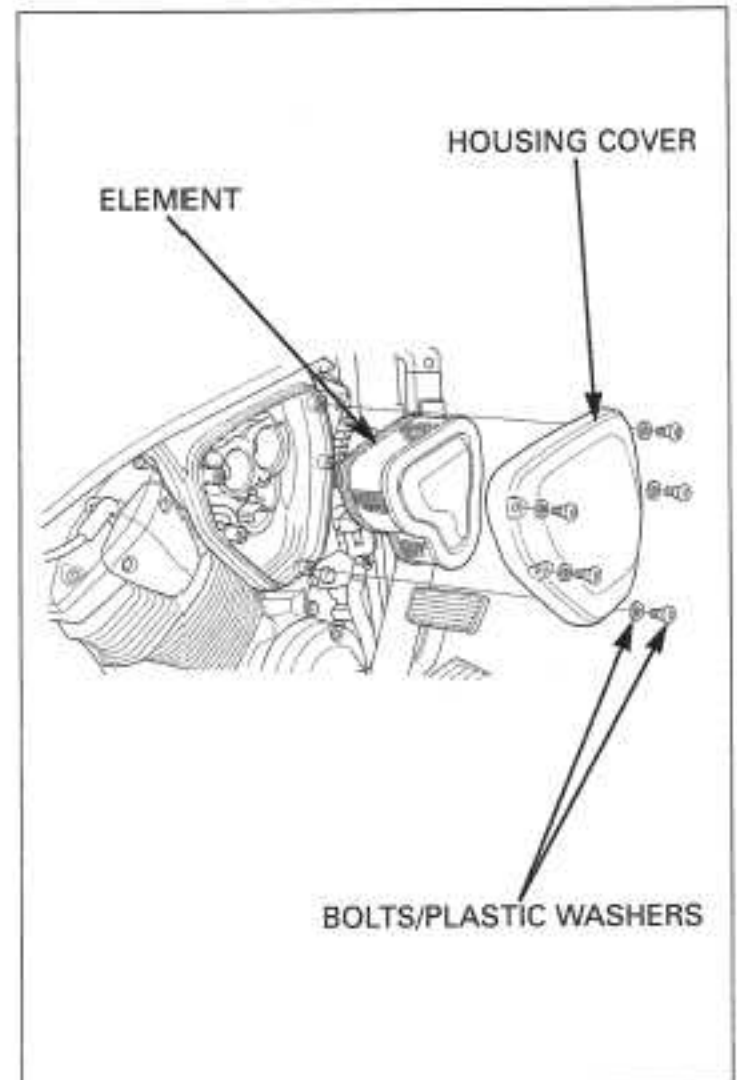



## CRANKCASE BREATHER

*Service more frequently when ridden in rain, at full throttle, or after the motorcycle is washed or overturned. Service if deposits can be seen in the transparent section of the breather hose.*

Remove the crankcase breather hose from the air cleaner housing and drain deposits into a suitable container, then install the hose securely.

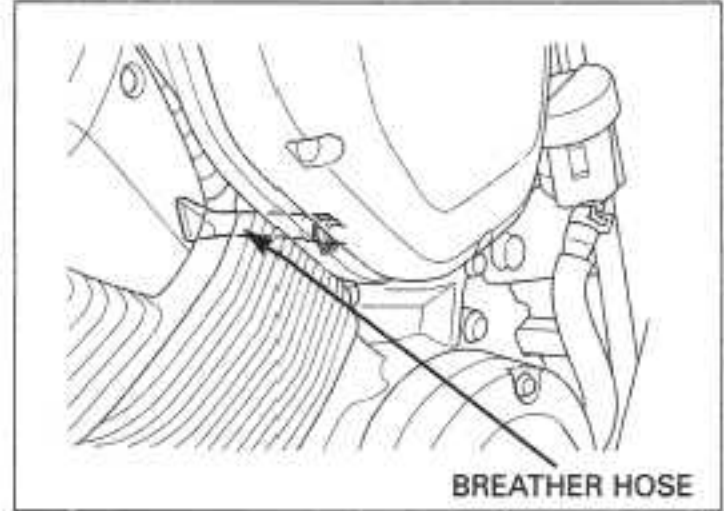

## SPARK PLUG

### REMOVAL

Remove the socket bolts and spark plug cap cover.

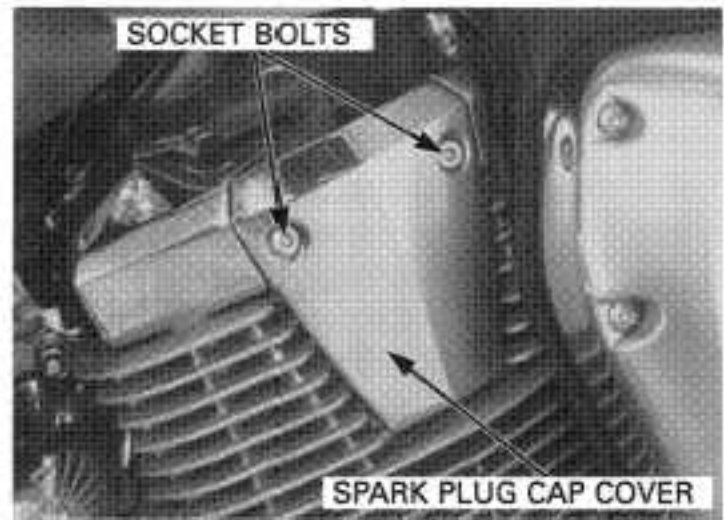

*Clean around the spark plug bases with compressed air before removing, and be sure that no debris is allowed to enter the combustion chamber.*

Disconnect the spark plug cap from the spark plug bases.

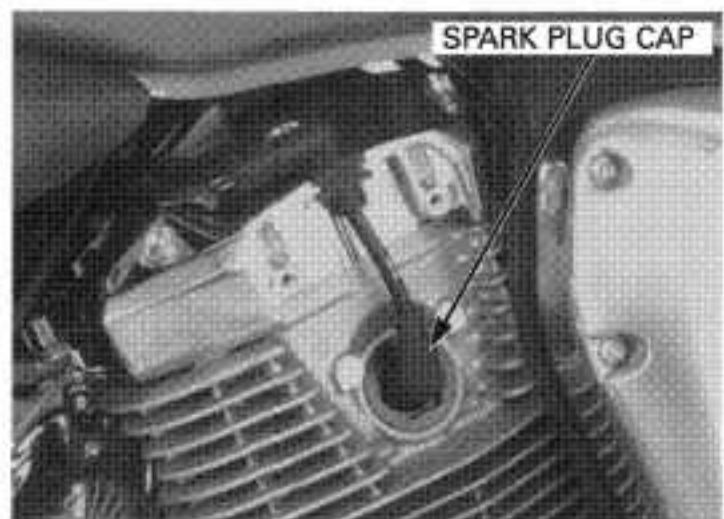

Remove the spark plug using the equipped spark plug wrench or an equivalent tool.

Inspect or replace as described in the maintenance schedule.

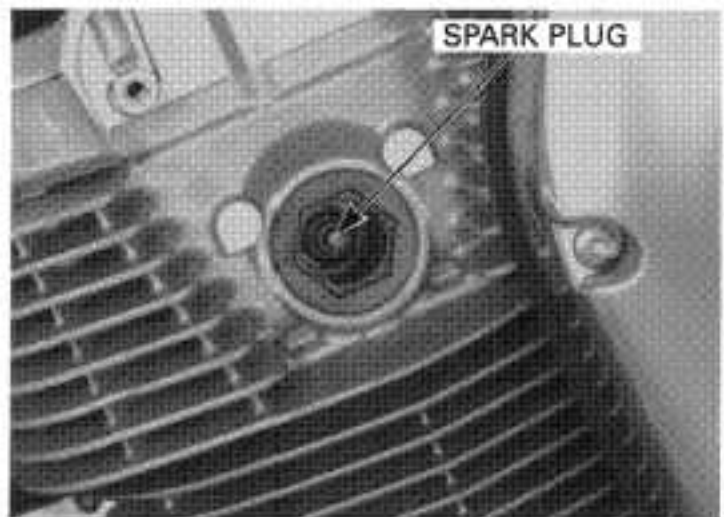



**INSPECTION**

Check the following and replace if necessary (recommended spark plug: page 3-2)

- Insulator for damage
- Electrodes for wear
- Burning condition, coloration

*This motorcycle's spark plug is equipped with an iridium center electrode. Replace the spark plug if the electrodes are contaminated.*

If the electrodes are contaminated with accumulated objects or dirt, replace the spark plug.

Replace the plug if the center electrode is rounded as shown in the illustration.

**SPECIFIED SPARK PLUG:**

- NGK: IFR6L11**
- DENSO: VK20PRZ11**

*Always use the specified spark plugs on this motorcycle.*

*To prevent damaging the iridium center electrode, use a wire type feeler gauge to check the spark plug gap.*

Check the gap between the center and side electrodes with a wire type feeler gauge.

Make sure that the 1.0 mm (0.04 in) diameter plug gauge does not insert between the gap.

*Do not adjust the spark plug gap. If the gap is out of specification, replace with a new one.*

If the gauge can be inserted into the gap, replace the plug with a new one.

Reinstall the spark plug in the cylinder head and hand tighten, then torque to specification.

**TORQUE: 18 N·m (1.8 kgf·m, 13 lbf·ft)**

If using a new plug, install as follows: Install and hand tighten the new spark plug, then tighten it about 1/2 of a turn after the sealing washer contacts the seat of the plug hole.

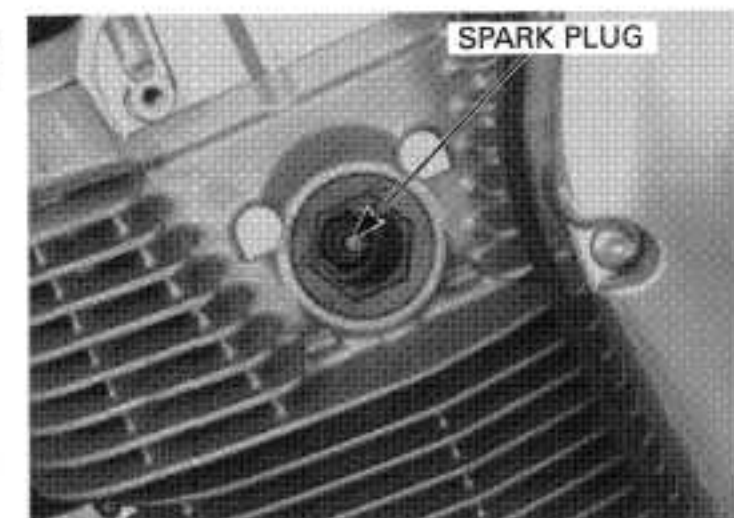
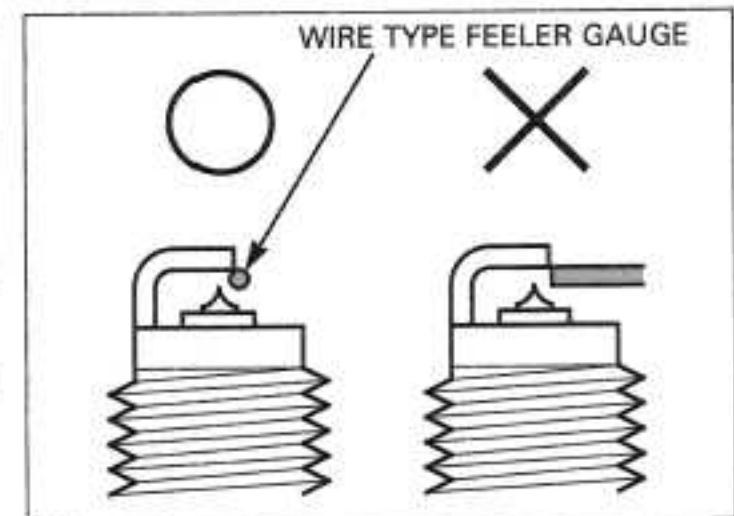
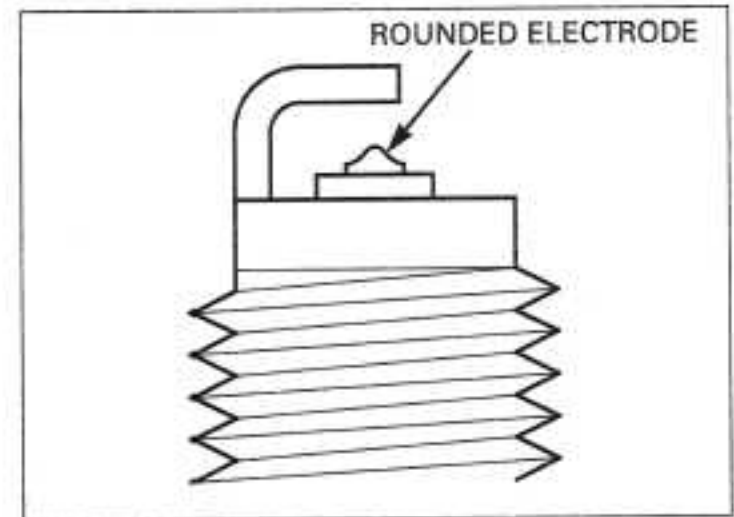
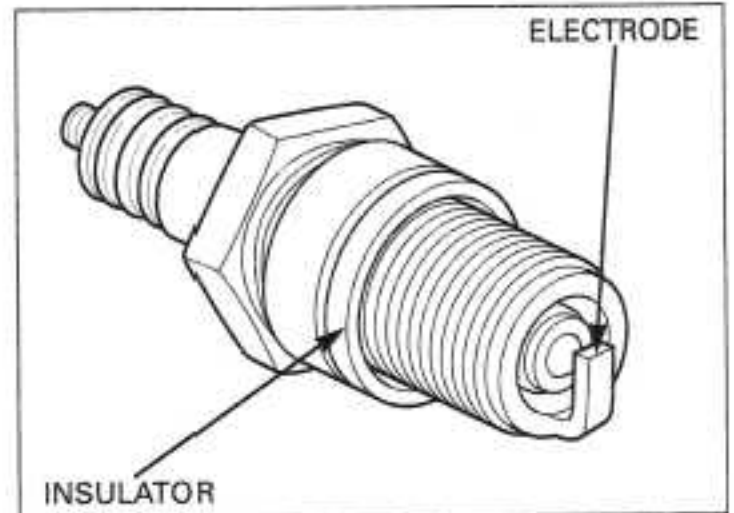

## MAINTENANCE

Connect the spark plug cap to the spark plug.  
Install the spark plug wire grommet to the groove in the cylinder head cover securely.

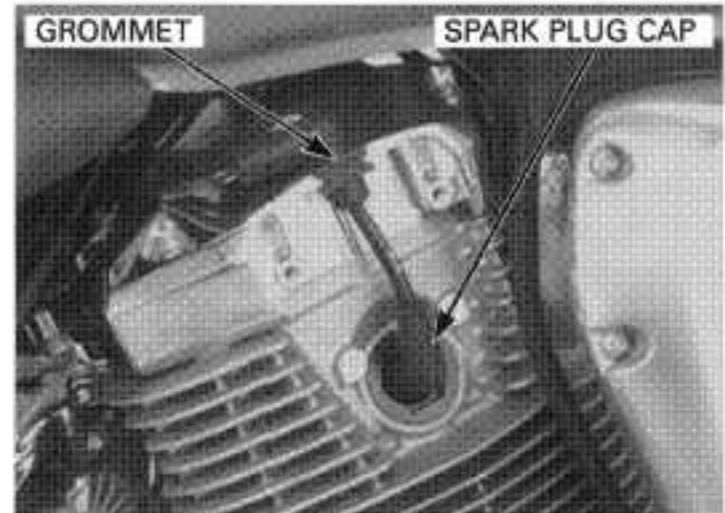

If the rubber plugs were removed, install them in the holes in the spark plug cap cover.  
Install the spark plug cap cover.

Install and tighten the socket bolts securely.

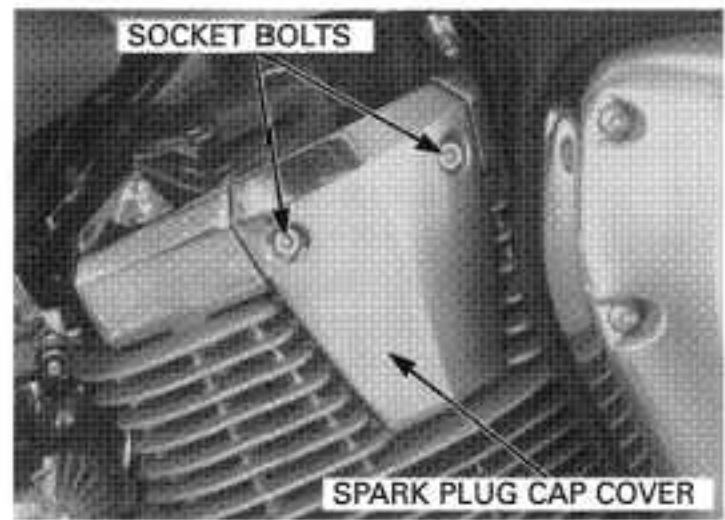

## VALVE CLEARANCE

*Inspect and adjust the valve clearance while the engine is cold (below 35°C/95°F).*

### INSPECTION

Remove the fuel tank (page 5-56).

Remove the socket bolts using the equipped tool.  
Remove the timing cover.

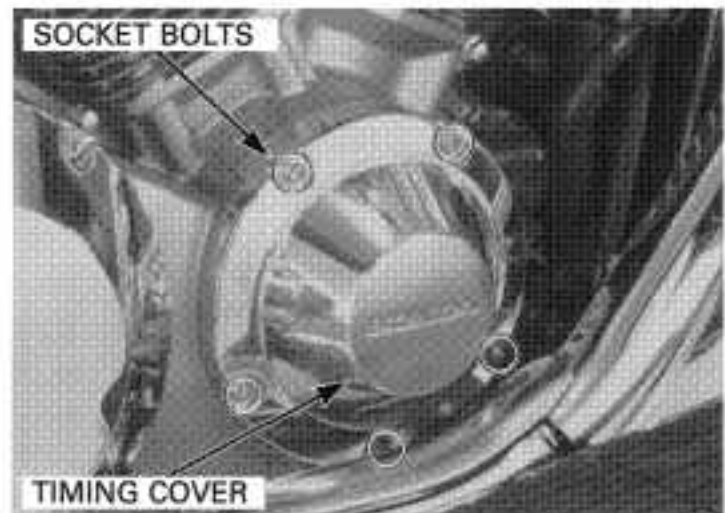

Remove the crankshaft hole cap.

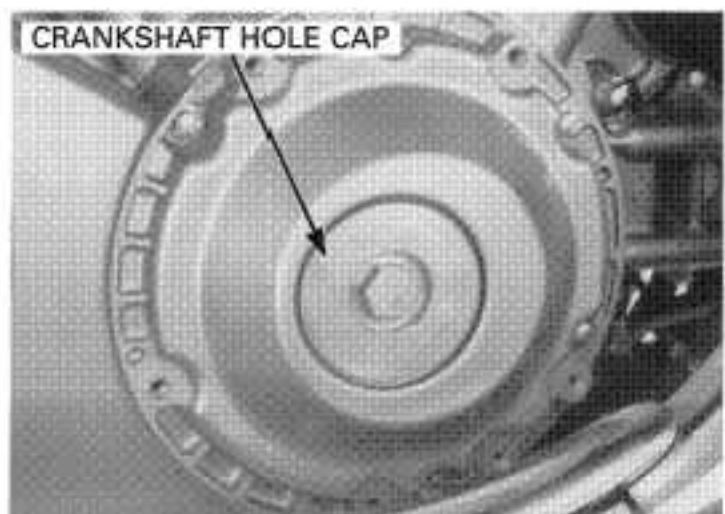

For front cylinder:  
 Remove the intake duct control solenoid valve bolt (page 5-80).  
 Remove the thermostat housing bolt (page 6-9).

For rear cylinder:  
 Remove the thermostat housing bolt (page 6-9).  
 Remove rear ignition coil (page 17-5).

Remove the bolts, adjusting cover and O-ring.

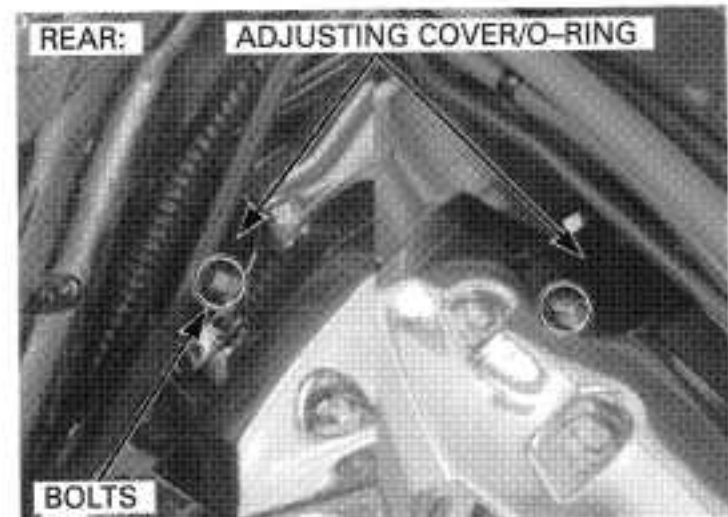
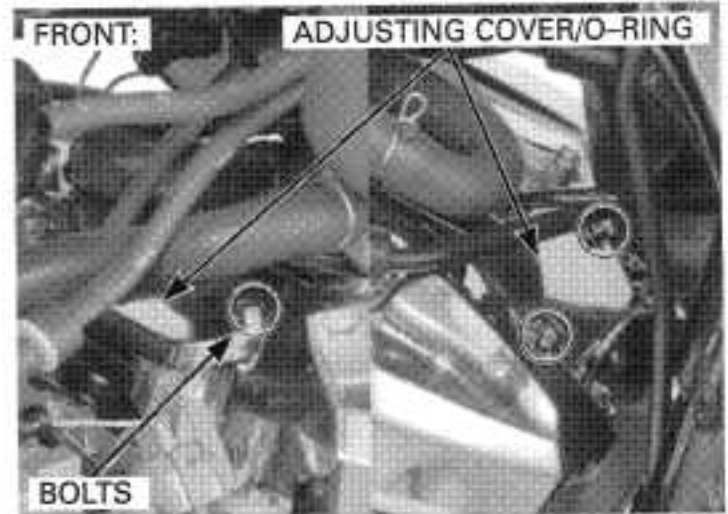

Turn the crankshaft clockwise, align the "FT" mark on the primary drive gear with the index mark on the right crankcase cover for the front cylinder.

Make sure the piston is at TDC (Top Dead Center) on the compression stroke.

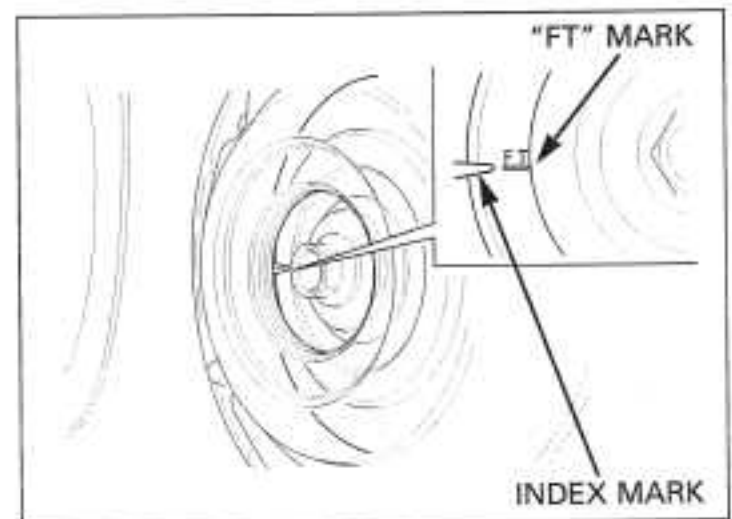

Turn the crankshaft clockwise, align the "RT" mark on the primary drive gear with the index mark on the right crankcase cover for the rear cylinder.

Make sure the piston is at TDC (Top Dead Center) on the compression stroke.

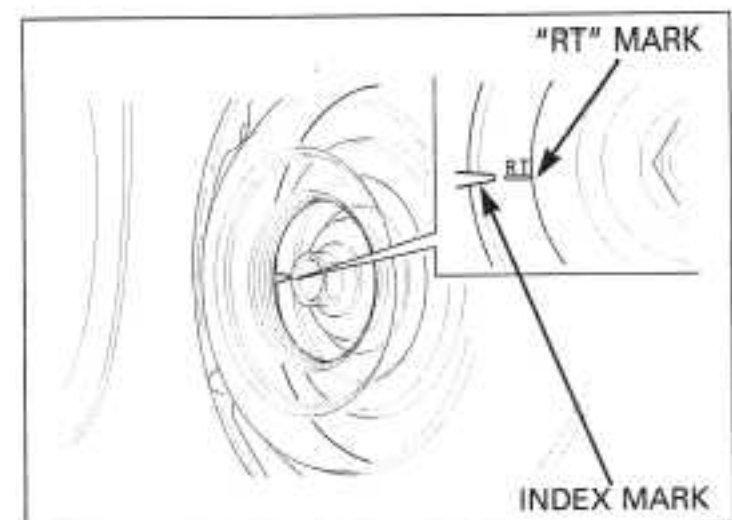

## MAINTENANCE

Inspect the valve clearance of all valves by inserting a feeler gauge between the adjusting screw and valve stem end.

### VALVE CLEARANCE:

IN:  $0.13 \pm 0.02$  mm ( $0.005 \pm 0.001$  in)

EX:  $0.32 \pm 0.02$  mm ( $0.013 \pm 0.001$  in)

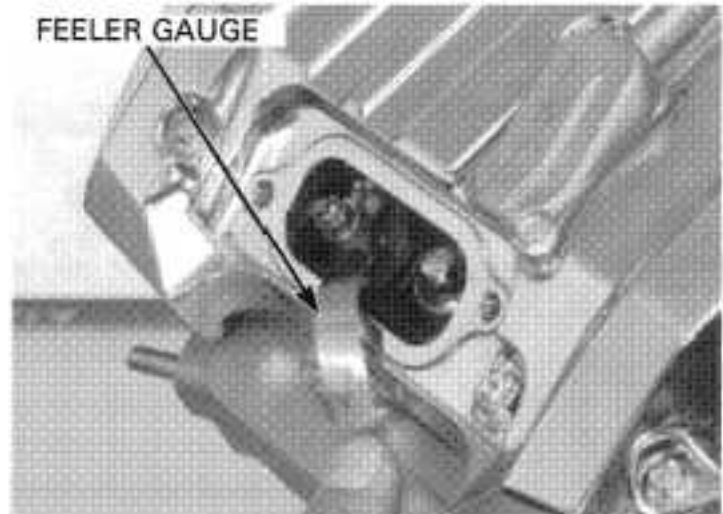

### ADJUSTMENT

Loosen the lock nut and turn the adjusting screw until there is a slight drag on the feeler gauge.

Hold the adjusting screw and tighten the lock nut to the specified torque.

### TOOL:

Valve adjusting screw wrench, 4 mm 07908-KE90100

TORQUE: 22 N·m (2.2 kgf·m, 16 lbf·ft)

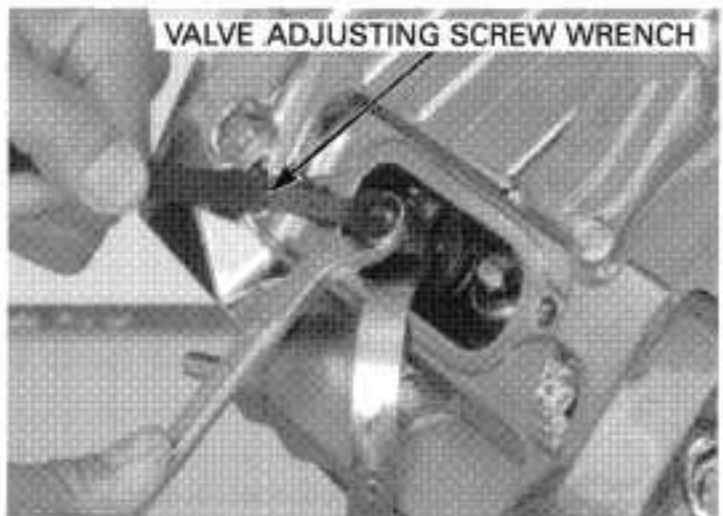



Apply engine oil to the new O-rings and install the front and rear valve adjusting covers.

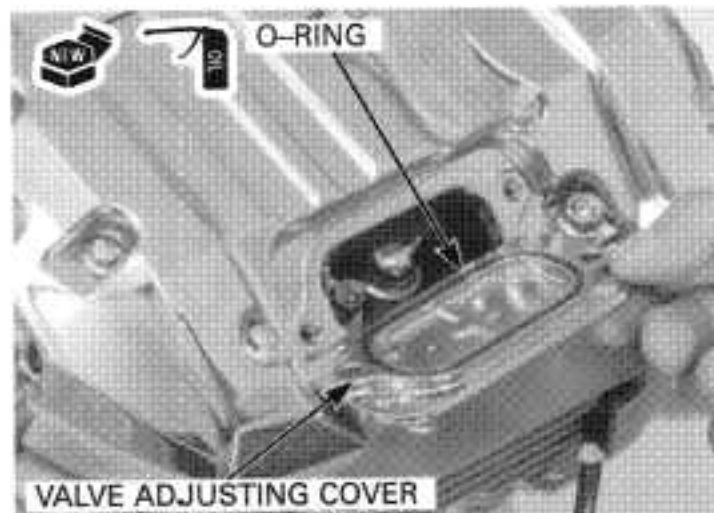

Apply engine oil to the new O-ring. Apply grease to the crankshaft hole cap threads. Install and tighten the crankshaft hole cap to the specified torque.

**TORQUE: 18 N·m (1.8 kgf·m, 13 lbf·ft)**

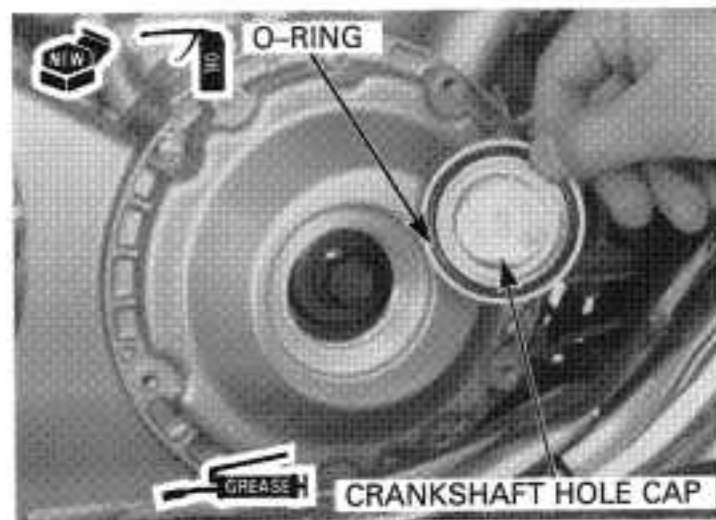

Install the timing cover and tighten the socket bolts securely.

Install the removed parts in the reverse order of removal.

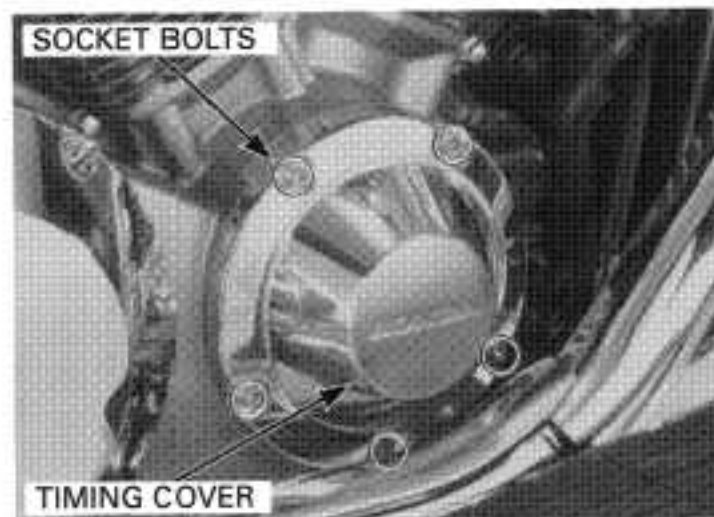



## ENGINE OIL/OIL FILTER

### OIL LEVEL INSPECTION

- Check the oil level after starting the engine and allowing the oil to circulate through the engine thoroughly. It is especially important on a dry sump engine, due to the comparatively large volume of oil.
- Do not snap the throttle while idling or the oil level reading will be inaccurate.

Place the vehicle on level ground. Start the engine and let it idle for 5 minutes. If the air temperature is below 10 °C (50 °F), let the engine idle for an additional 5 minutes (a total of 10 minutes). Turn off the engine and support the motorcycle on a level surface.

After a few minutes, remove the oil filler cap/dipstick and wipe it clean.

Check the oil level by inserting the oil filler cap/dipstick into the engine without screwing it in.

The engine contains a sufficient amount of oil if the oil level is between the upper and lower level marks on the oil filler cap/dipstick.

If the level is near or below the lower level mark, remove the oil filler cap/dipstick and fill the crankcase with the recommended oil to the upper level mark.

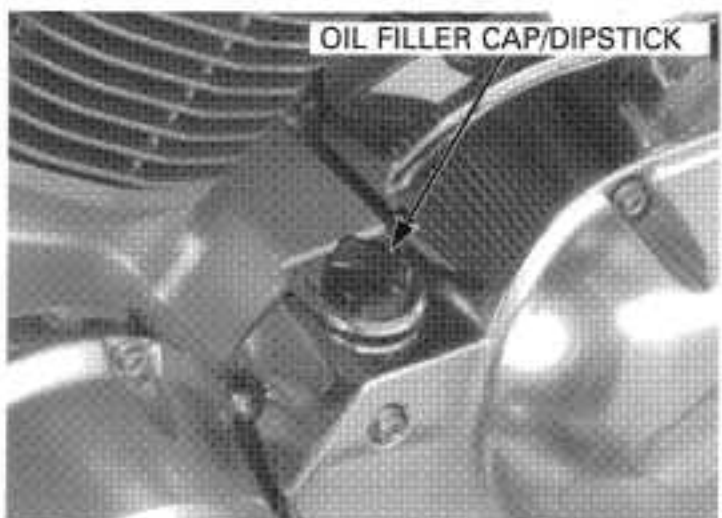
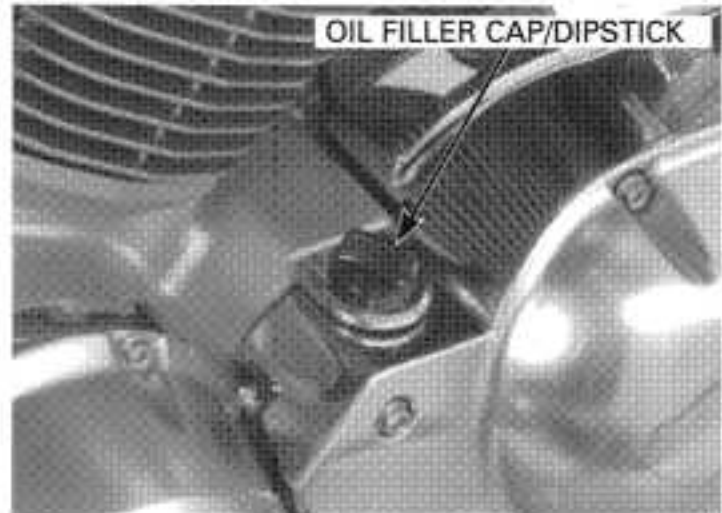

*Other viscosities shown in the chart on page 3-14 may be used when the average temperature in your riding area is within the indicated range.*

### RECOMMENDED ENGINE OIL:

**Pro Honda GN4 or HP4 4-stroke oil (U.S.A. and Canada), or Honda 4-stroke oil (Canada only), or equivalent motor oil**

**API service classification: SF or SG**

**Viscosity: 10W-40**

Reinstall the oil filler cap/dipstick.

## ENGINE OIL & FILTER CHANGE

*Change the engine oil with the engine warm and the motorcycle on level ground to assure complete draining.*

Warm up the engine.

Stop the engine and remove the oil filler cap/dipstick.

Remove the drain bolts, drain the oil completely.

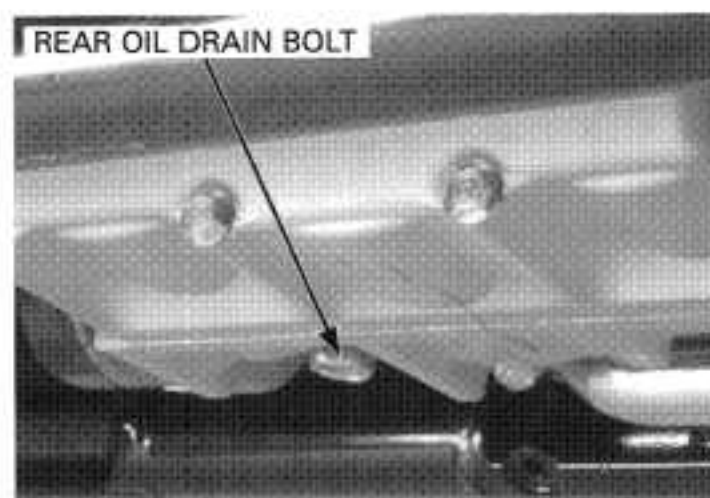
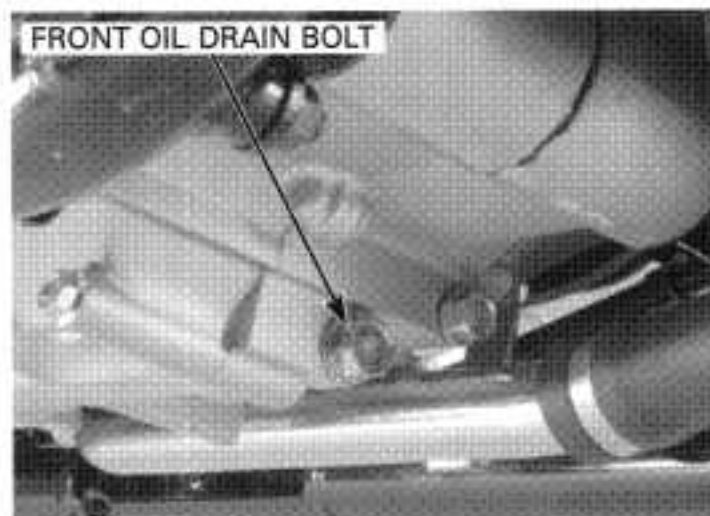

Remove and discard the oil filter cartridge using the special tool.

**TOOL:**  
Oil filter wrench

07HAA-PJ70101 or  
07HAA-PJ70100

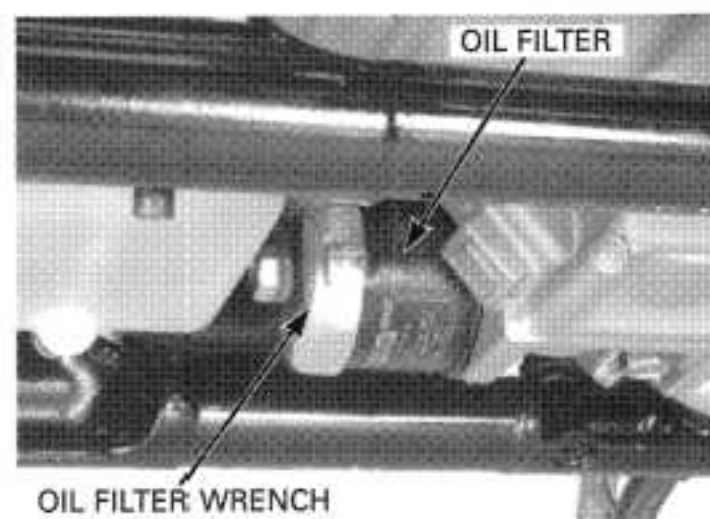

Check that the sealing washer on the front oil drain bolt is in good condition, and replace if necessary. Install and tighten the front oil drain bolt.

**TORQUE:** 29 N·m (3.0 kgf·m, 22 lbf·ft)



## MAINTENANCE

Check that the sealing washer on the rear oil drain bolt is in good condition, and replace if necessary. Install and tighten the rear oil drain bolt.

**TORQUE: 29 N·m (3.0 kgf·m, 22 lbf·ft)**

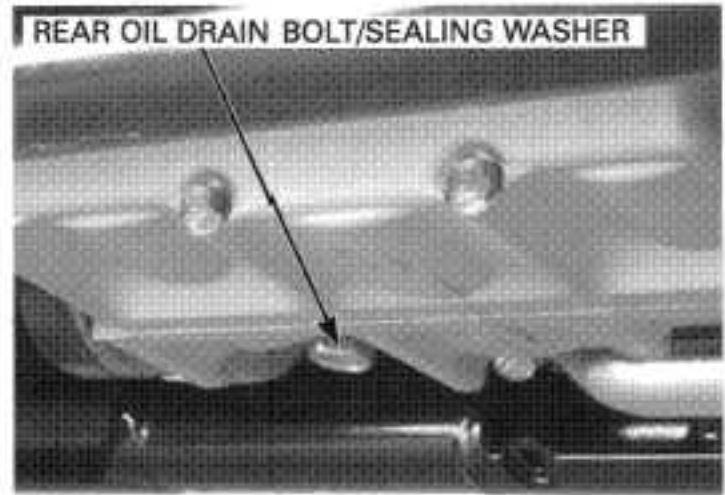

Apply clean engine oil to the new oil filter O-ring.

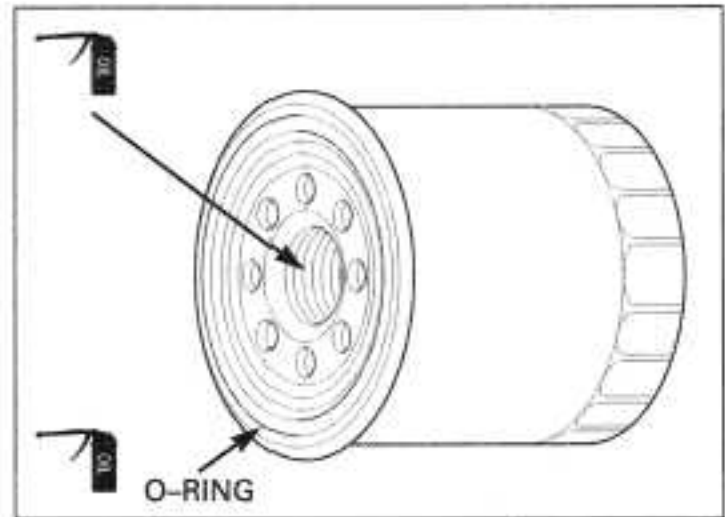

Install the new oil filter and tighten it to the specified torque.

**TOOL:**  
Oil filter wrench

07HAA-PJ70101 or  
07HAA-PJ70100

**TORQUE: 26 N·m (2.7 kgf·m, 20 lbf·ft)**

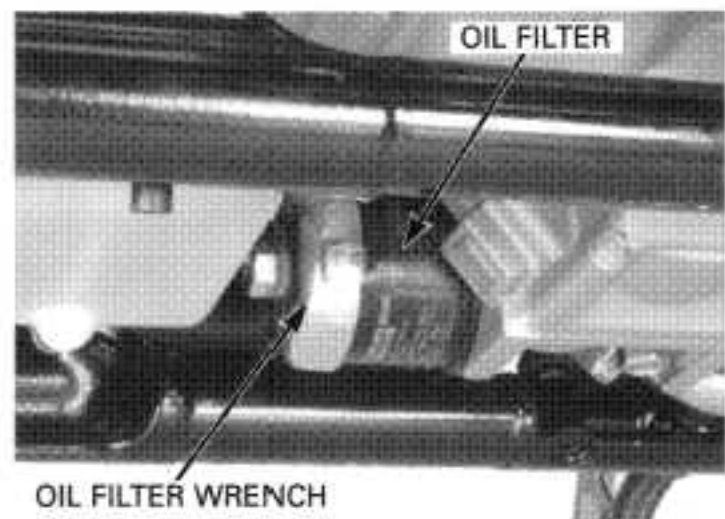

Fill the crankcase with the recommended engine oil.

### OIL CAPACITY:

3.5 liter (3.7 US qt, 3.1 Imp qt) after draining  
3.7 liter (3.9 US qt, 3.3 Imp qt) after draining/filter change

Install the oil filler cap/dipstick.

Start the engine and let it idle for 3 minutes.  
Stop the engine.  
After a few minutes, recheck the oil level.  
Make sure there are no oil leaks.

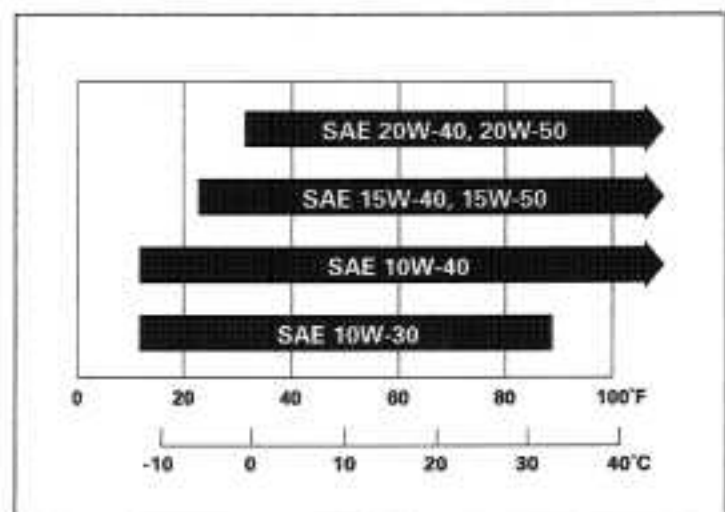

## ENGINE IDLE SPEED

- Inspect and adjust the idle speed after all other engine maintenance items have been performed and are within specifications.
- The engine must be warm for accurate idle speed inspection and adjustment.

Warm up the engine for about 10 minutes.  
Turn the throttle stop screw as required to obtain the specified idle speed.

**IDLE SPEED: 800 ± 100 rpm**



## RADIATOR COOLANT

Check the coolant level of the reserve tank with the engine running at normal operating temperature. The level should be between the upper and lower level lines.

If necessary, add the recommended coolant.

### RECOMMENDED ANTIFREEZE:

**Pro Honda HP coolant or equivalent high quality ethylene glycol antifreeze containing silicate-free corrosion protection inhibitors.**

Remove the left side cover (page 2-2).

Remove the reserve tank filler cap and fill to the "UPPER" level line with a 1:1 mixture of distilled water and antifreeze.  
Reinstall the filler cap.

Install the left side cover (page 2-2).

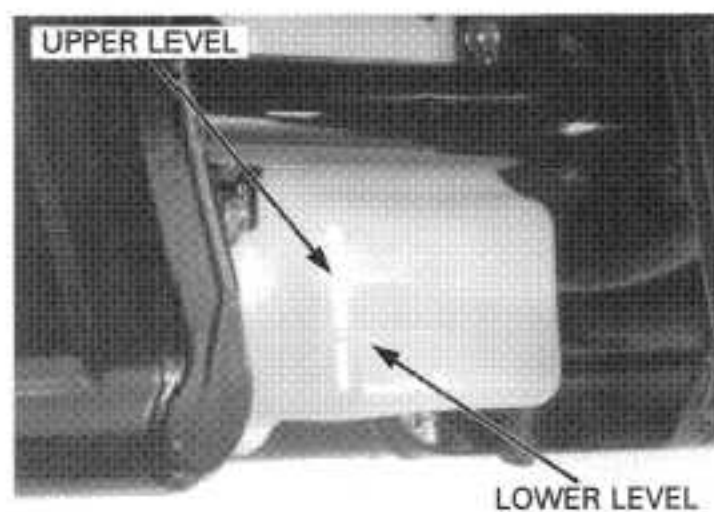

## COOLING SYSTEM

Check the radiator air passages for clogs or damage.





## MAINTENANCE

Straighten bent fins, and remove insects, mud or other obstructions with compressed air or low water pressure.

Replace the radiator if the air flow is restricted over more than 20% of the radiating surface.

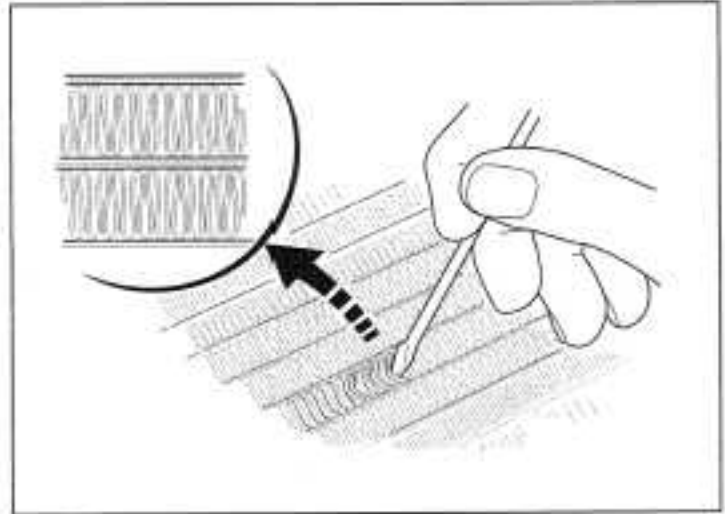

Inspect the radiator hoses for cracks or deterioration, and replace if necessary.

Check the tightness of all hose clamps and fasteners.

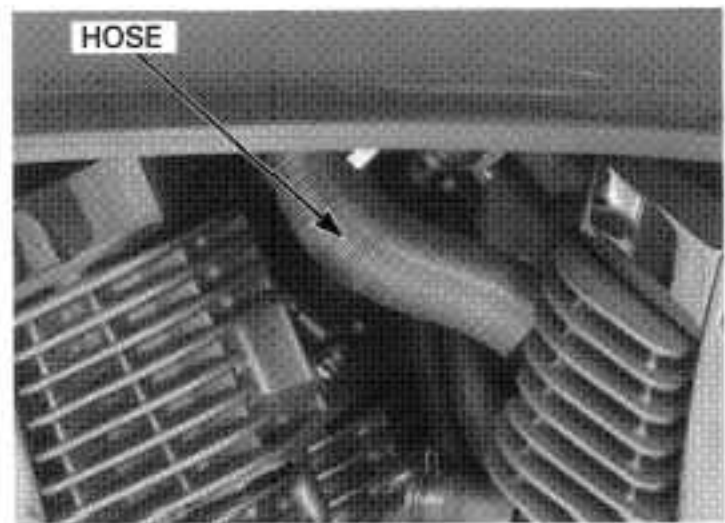

## SECONDARY AIR SUPPLY SYSTEM

- This model is equipped with a built-in secondary air supply system. The pulse secondary air supply system is located on the cylinder head cover.
- The secondary air supply system introduces filtered air into exhaust gases in the exhaust port. The secondary air is drawn into the exhaust port whenever there is a negative pressure pulse in the exhaust system. This charged secondary air promotes burning of the unburned exhaust gases and changes a considerable amount of hydrocarbons and carbon monoxide into relatively harmless carbon dioxide and water.

Remove the fuel tank (page 5-56).

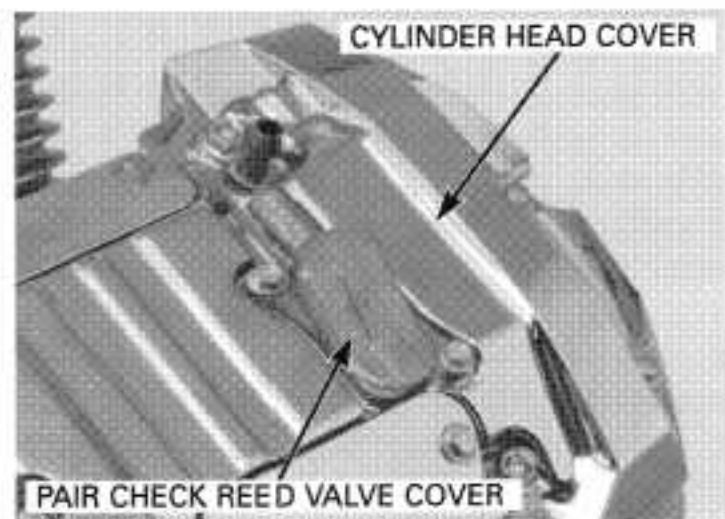

*If the hoses show any signs of heat damage, inspect the PAIR check valve in the PAIR reed valve cover for damage.*

Check the PAIR (pulse secondary air injection) hoses between the PAIR control solenoid valve and cylinder head cover for deterioration, damage or loose connections. Make sure the hoses are not cracked.

Check the air suction hose between the air cleaner housing and PAIR control solenoid valve for deterioration, damage or loose connections.

Make sure the hoses are not kinked, pinched or cracked.

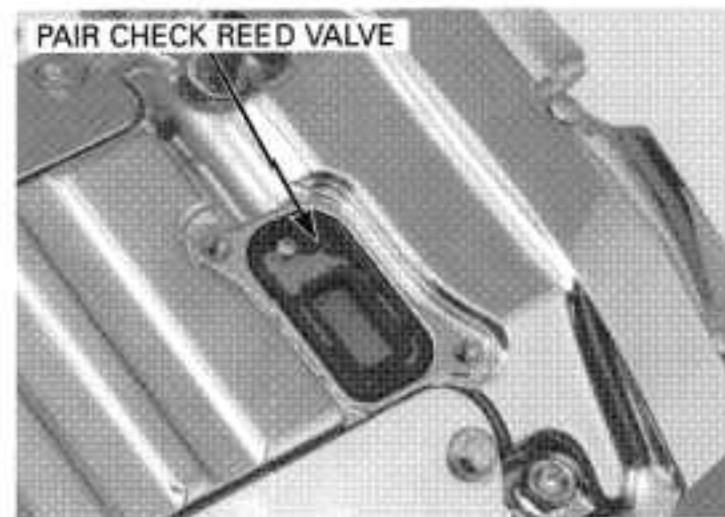



## EVAPORATIVE EMISSION CONTROL SYSTEM (CALIFORNIA TYPE ONLY)

Check the hoses between the fuel tank, EVAP canister, EVAP purge control solenoid valve for deterioration, damage or loose connections.

Check the EVAP canister for cracks or other damage.

Refer to the Vacuum Hose Routing Diagram Label (page 1-36) and Cable & Harness Routing (page 1-23) for hose connections.

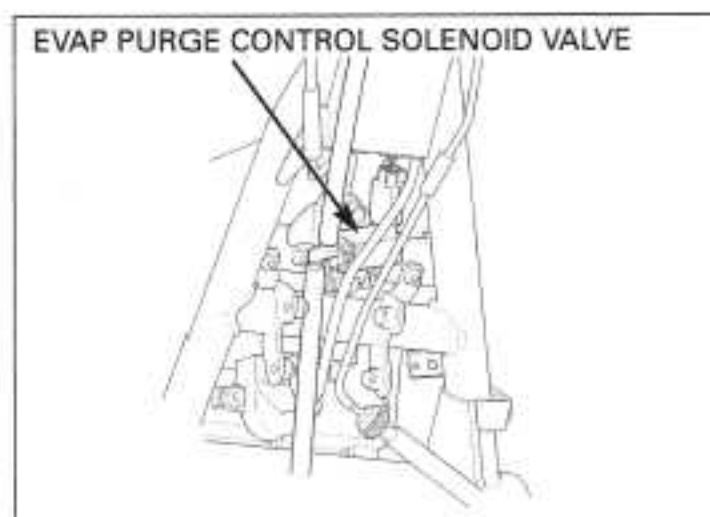
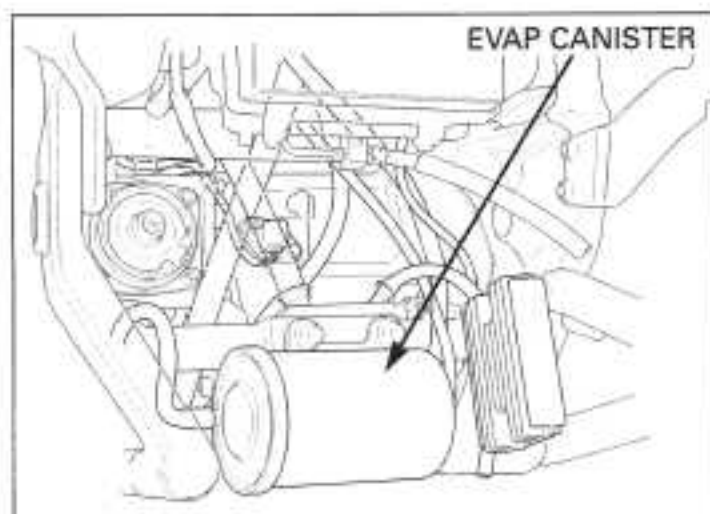

## FINAL DRIVE OIL

### LEVEL CHECK

Place the motorcycle on its side stand on a level surface.

Remove the final drive oil filler cap.

Check that the oil level is to the lower edge of the oil filler hole.

**RECOMMENDED OIL:** Hypoid gear oil, SAE #80

Coat a new O-ring with grease and install it onto the oil filler cap.

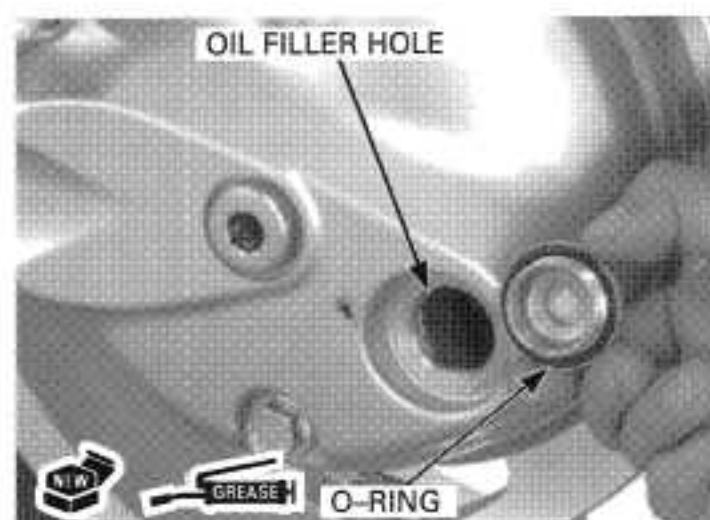
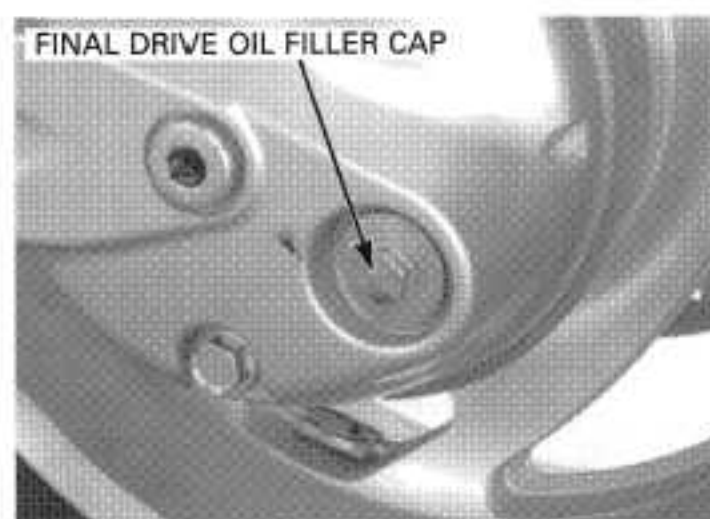

## MAINTENANCE

Install and tighten the final drive oil filler cap to the specified torque.

**TORQUE: 12 N·m (1.2 kgf·m, 9 lbf·ft)**

### OIL CHANGE

Place the motorcycle on its side stand on a level surface.

Remove the oil filler cap and drain bolt, slowly turn the rear wheel and drain the oil.

When the oil is completely drained, clean the drain bolt, replace the sealing washer and tighten it to the specified torque.

**TORQUE: 20 N·m (2.0 kgf·m, 14 lbf·ft)**

Fill the gear case with the recommended oil to the lower edge of the filler hole.

#### OIL CAPACITY:

120 cm<sup>3</sup> (4.1 US oz, 4.2 Imp oz) at draining

150 cm<sup>3</sup> (5.1 US oz, 5.3 Imp qt) at disassembly

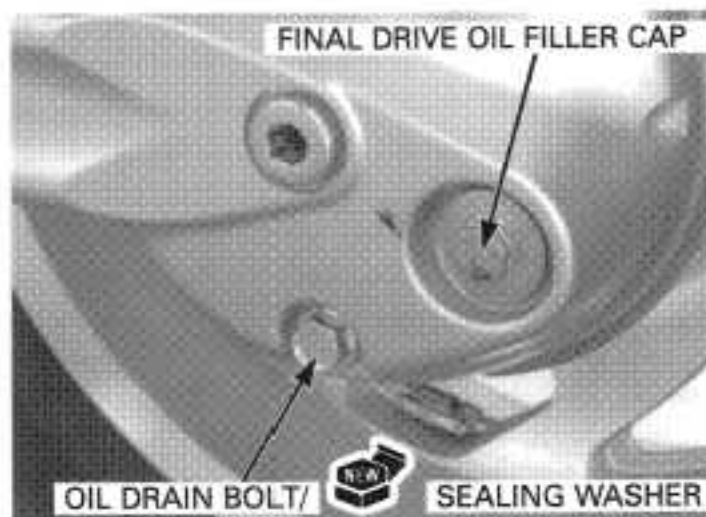

## BRAKE FLUID

### NOTICE

- Do not mix different types of fluid, as they are not compatible with each other.
- Do not allow foreign material to enter the system when filling the reservoir.
- Avoid spilling fluid on painted, plastic or rubber parts. Place a rag over these parts whenever the system is serviced.

When the fluid level is low, check the brake pads for wear (see next page). A low fluid level may be due to wear of the brake pads. If the brake pads are worn, the caliper piston is pushed out, and this accounts for a low reservoir level. If the brake pads are not worn and the fluid level is low, check the entire system for leaks (see next page).

### FRONT BRAKE

Turn the handlebar so that the reservoir is level and check the front brake fluid reservoir level.

If the level is near the lower level line, check the brake pad wear (page 3-19).

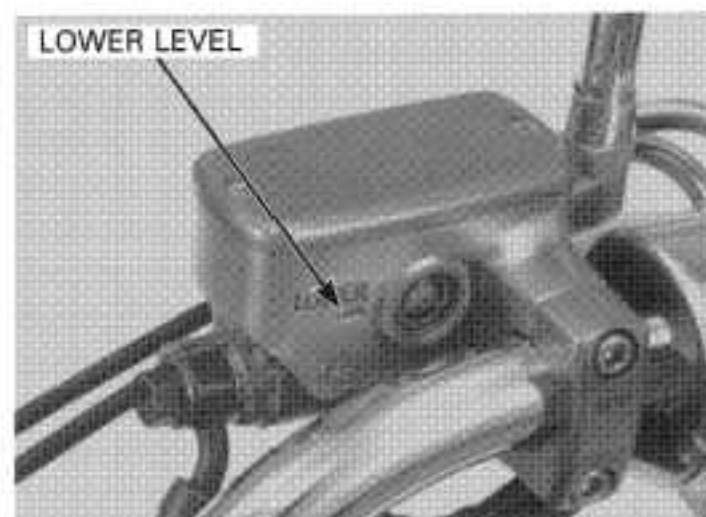

## REAR BRAKE

Place the motorcycle on a level surface, and support it in an upright position.  
Check the rear brake fluid reservoir level.  
If the level is near the lower level line, check the brake pad wear (see below).

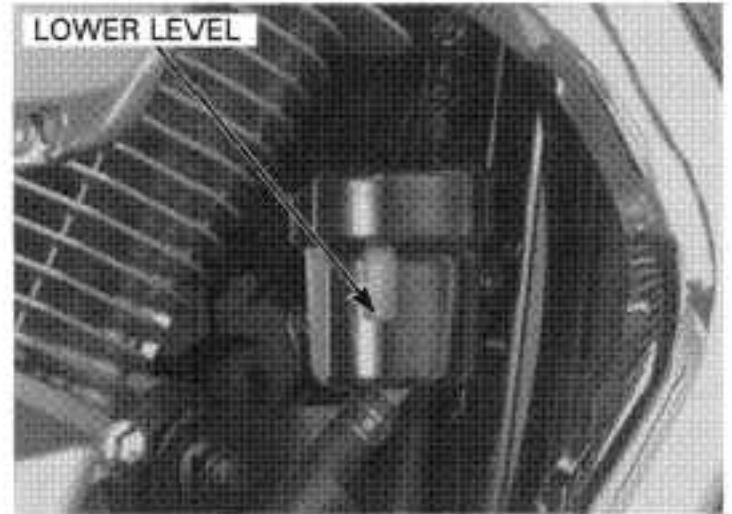

## BRAKE PAD WEAR

### FRONT BRAKE PADS

Check the brake pads for wear.  
Replace the brake pads if either pad is worn to the bottom of the wear limit groove.

Refer to page 15-10 for brake pad replacement.

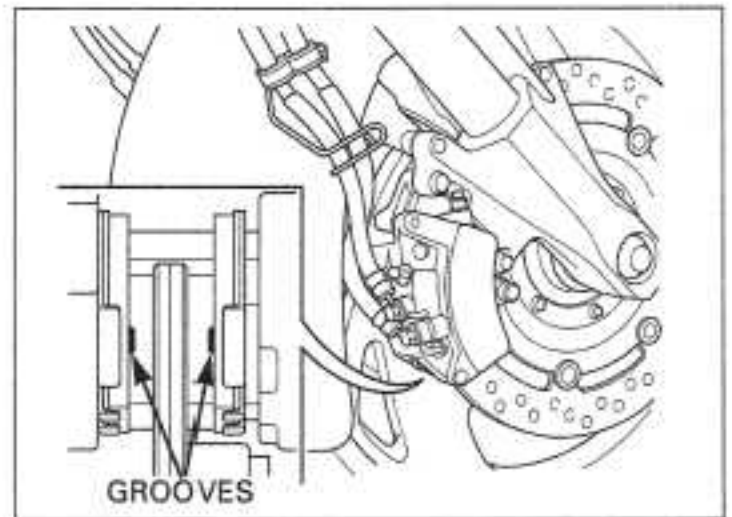

### REAR BRAKE PADS

Check the brake pads for wear.  
Replace the brake pads if either pad is worn to the bottom of the wear limit groove.

Refer to page 15-11 for brake pad replacement.

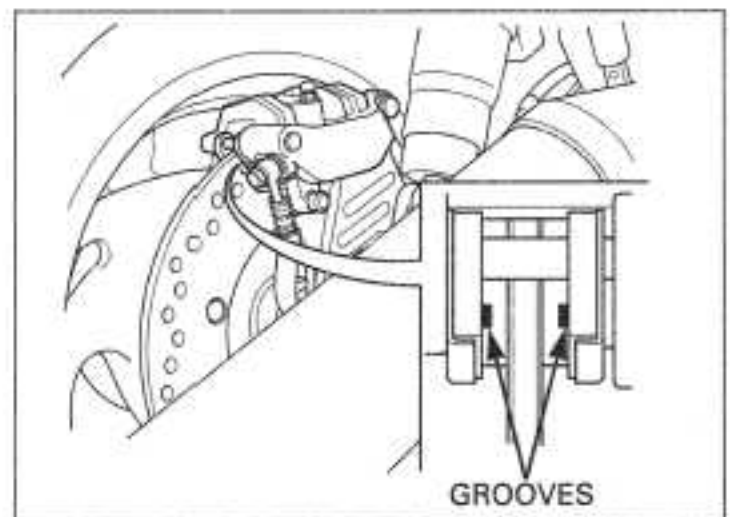

## BRAKE SYSTEM

### INSPECTION

This model is equipped with a Linked Brake System.  
Check the rear brake operation as follows:  
Place the vehicle on level ground and shift the transmission into neutral.

*Do not use the oil filter as a jacking point.*

Support the motorcycle to raise the front wheel off the ground.  
Apply the rear brake pedal.  
Make sure the front wheel does not turn while the rear brake pedal is applied.

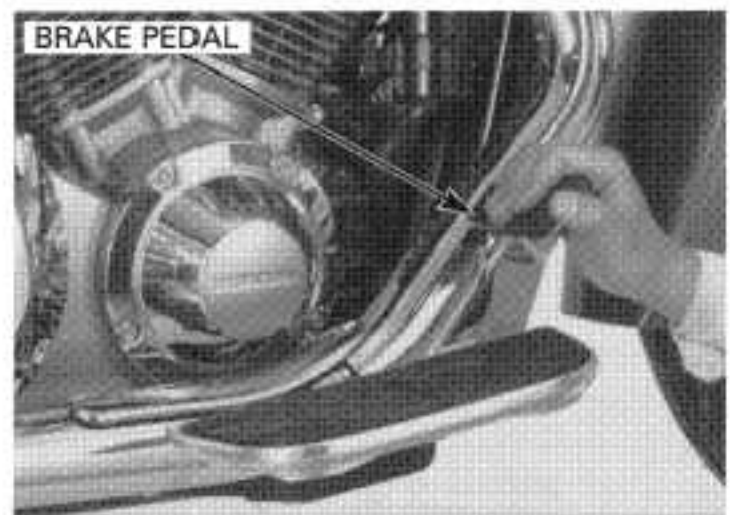

## MAINTENANCE

Firmly apply the brake lever or pedal, and check that no air has entered the system.

If the lever or pedal feels soft or spongy when operated, bleed the air from the system.

Inspect the brake hose and fittings for deterioration, cracks and signs of leakage.

Tighten any loose fittings.

Replace hoses and fittings as required.

Refer to page 15-5 for brake bleeding procedures.

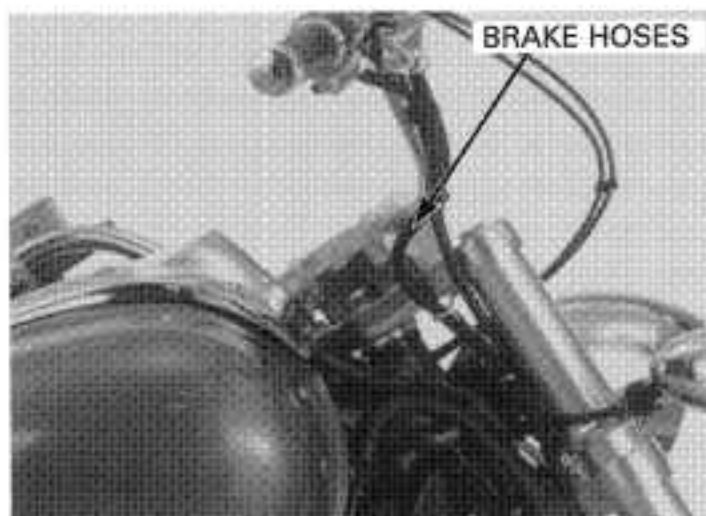

## BRAKE LIGHT SWITCH

*The front brake light switch does not require adjustment.*

Adjust the brake light switch so the brake light comes on just prior to the brake actually being engaged.

If the light fails to come on, adjust the switch so the light comes on at the proper time.

Hold the switch body and turn the adjuster. Do not turn the switch body.

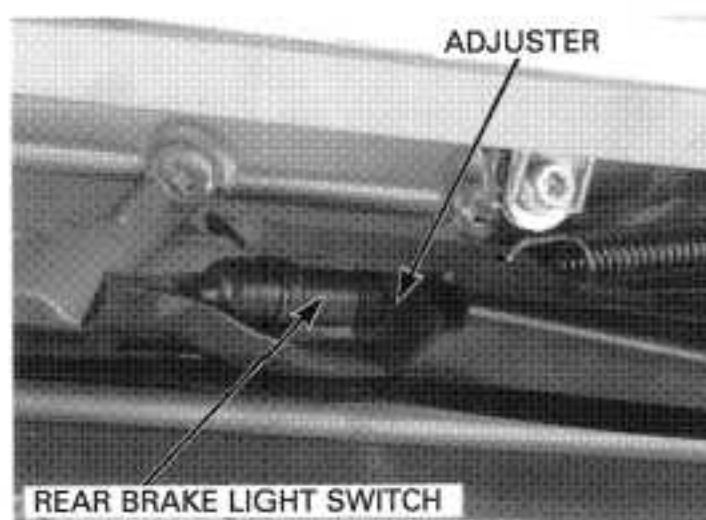

## HEADLIGHT AIM

*Adjust the headlight beam as specified by local laws and regulations.*

Place the motorcycle on a level surface.

Adjust the headlight beam vertically by turning the vertical beam adjusting screw.

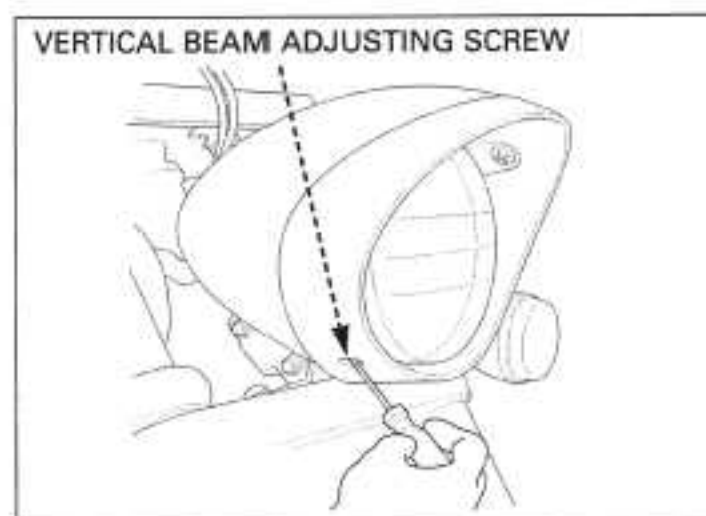

Adjust the headlight beam horizontally by turning the horizontal beam adjusting screw.

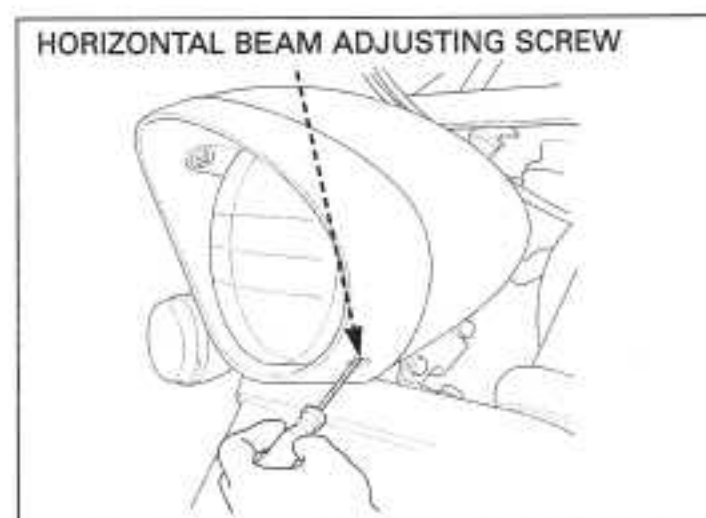



## CLUTCH SYSTEM

Firmly apply the clutch lever and check that no air has entered the system.  
If the lever feels soft or spongy when operated, bleed any air from the system.

Inspect the clutch hose/pipe and fittings for deterioration, cracks and signs of leakage.  
Tighten any loose fittings.  
Replace hoses/pipe and fittings as required.

Refer to page 10-4 for clutch bleeding procedures.

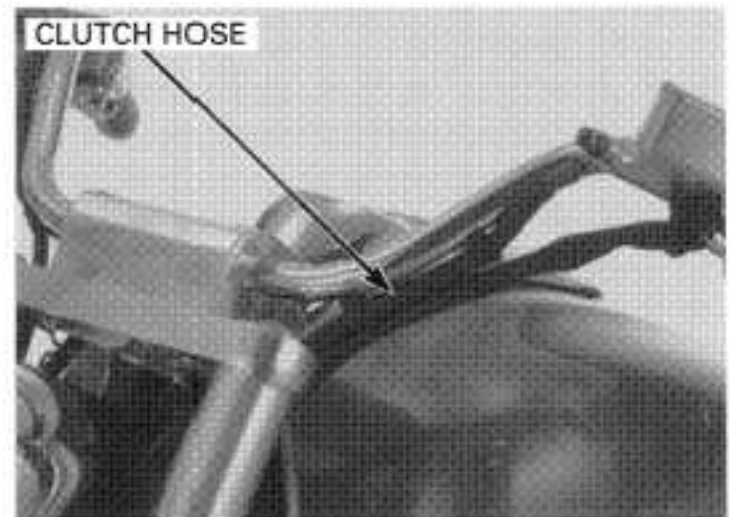
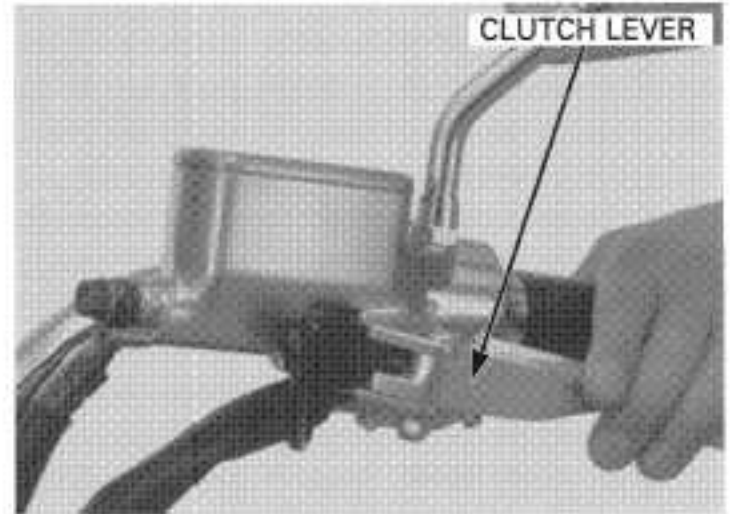

## CLUTCH FLUID

### NOTICE

- Do not mix different types of fluid, as they are not compatible with each other.
- Do not allow foreign material to enter the system when filling the reservoir.
- Avoid spilling fluid on painted, plastic or rubber parts. Place a rag over these parts whenever the system is serviced.

Turn the handlebar so the reservoir is level and check the clutch fluid reservoir level.

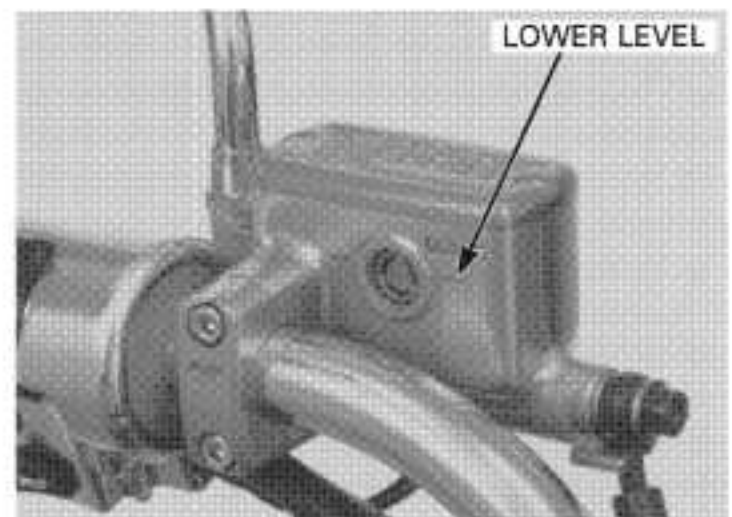

## SIDE STAND

Support the motorcycle on a level surface.

Check the side stand spring for damage or loss of tension.

Check the side stand assembly for smooth movement and lubricate the side stand pivot if necessary.

Check the side stand ignition cut-off system:

- Sit astride the motorcycle and raise the side stand.
- Start the engine with the transmission in neutral, then shift the transmission into gear, with the clutch lever squeezed.
- Move the side stand fully down.
- The engine should stop as the side stand is lowered.

If there is a problem with the system, check the side stand switch (section 19).

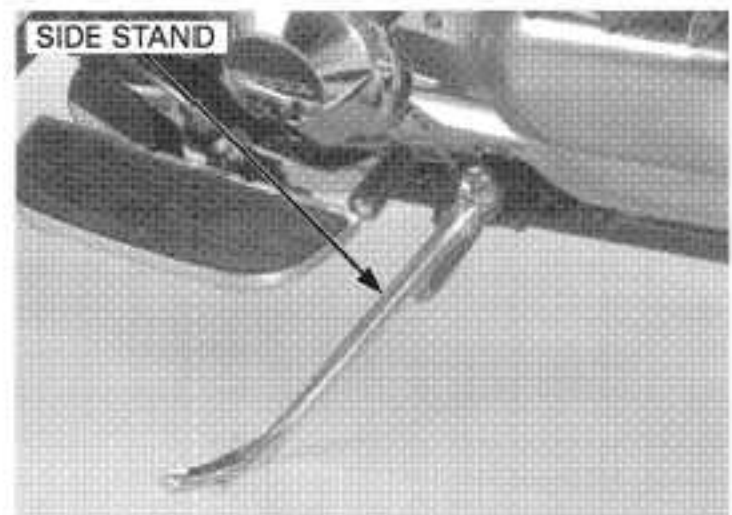

## SUSPENSION

### FRONT SUSPENSION INSPECTION

Check the action of the forks by operating the front brakes and compressing the front suspension several times.

Check the entire assembly for signs of leaks, damage or loose fasteners.

Replace damaged components which cannot be repaired.

Tighten all nuts and bolts.

Refer to section 13 for fork service.

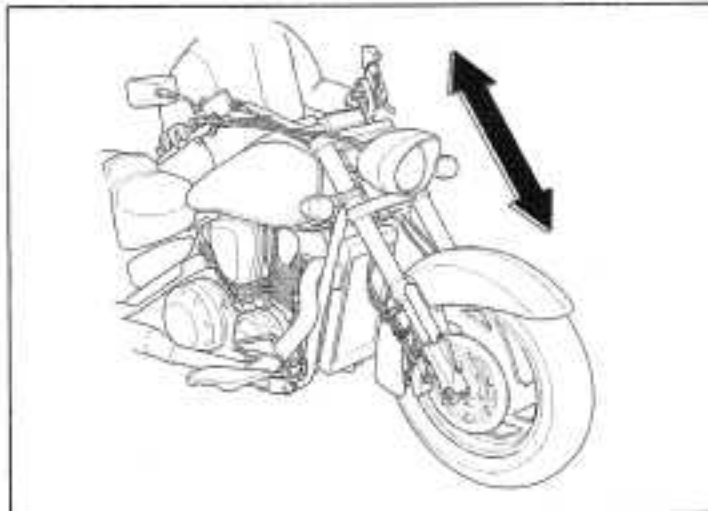

### REAR SUSPENSION INSPECTION

Support the motorcycle securely and raise the rear wheel off the ground.

Hold the swingarm and move the rear wheel side-ways with force to see if the wheel bearings are worn.

Check for worn swingarm bearings by grabbing the swingarm and attempting to move it side to side. Replace the bearings if any looseness is noted.

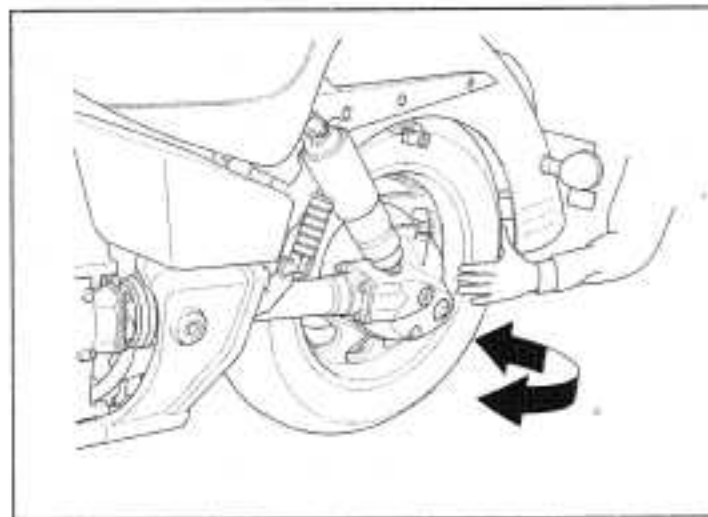

Check the action of the shock absorber by compressing it several times.

Check the entire shock absorber assembly for signs of leaks, damage or loose fasteners.

Replace damaged components which cannot be repaired.

Tighten all nuts and bolts.

Refer to section 14 for shock absorber service.

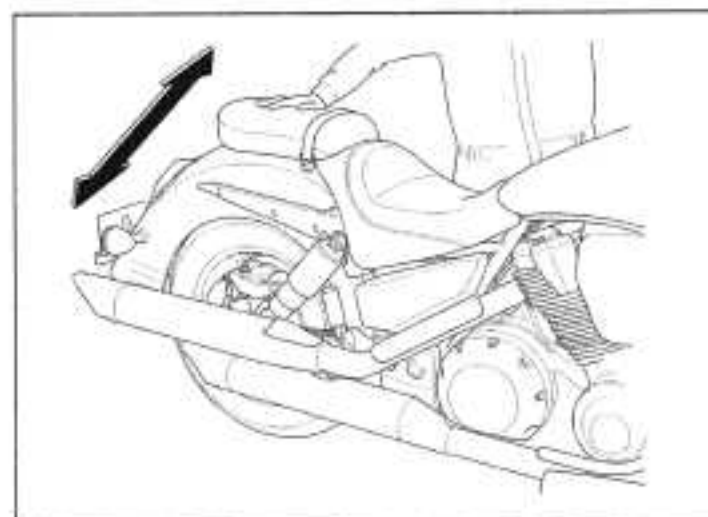

## NUTS, BOLTS, FASTENERS

Check that all chassis nuts and bolts are tightened to their correct torque values (page 1-12).

Check that all safety clips, hose clamps and cable stays are in place and properly secured.

## WHEELS/TIRES

Tire pressure should be checked when the tires are cold.

### RECOMMENDED TIRE PRESSURE AND TIRE SIZE:

		FRONT	REAR
Tire pressure kPa (kgf/cm <sup>2</sup> , psi)	Up to 90 kg (200 lb) load	225 (2.25, 33)	225 (2.25, 33)
	Up to maxi- mum weight capacity	225 (2.25, 33)	250 (2.50, 36)
Tire size		150/80R17M/C 72H	180/70R16M/C 77H
Tire brand	Dunlop	D251F	D251

Check the tires for cuts, embedded nails, or other damage.

Check the front and rear wheels for trueness (refer to section 13 and 14).

Measure the tread depth at the center of the tires. Replace the tires when the tread depth reaches the following limits.

### MINIMUM TREAD DEPTH:

**FRONT:** 1.5 mm (0.06 in)

**REAR:** 2.0 mm (0.08 in)

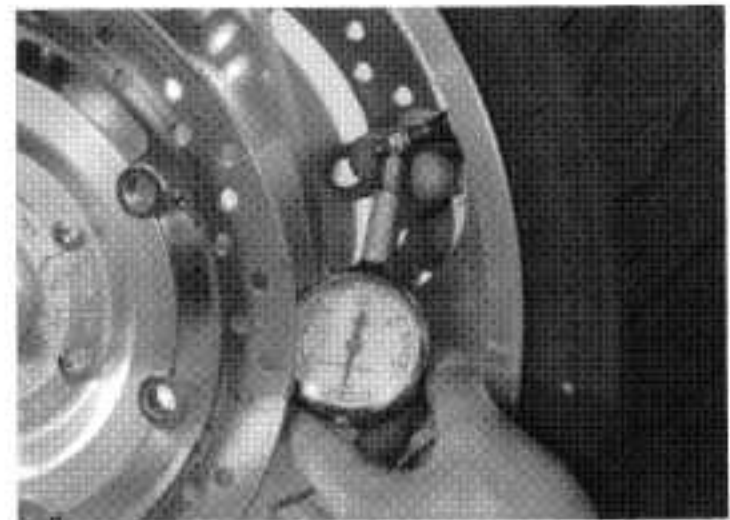

## STEERING HEAD BEARINGS

Check that the control cables do not interfere with handlebar rotation.

Support the motorcycle securely and raise the front wheel off the ground.

Check that the handlebar moves freely from side to side.

If the handlebar moves unevenly, binds, or has vertical movement, inspect the steering head bearings (section 13).

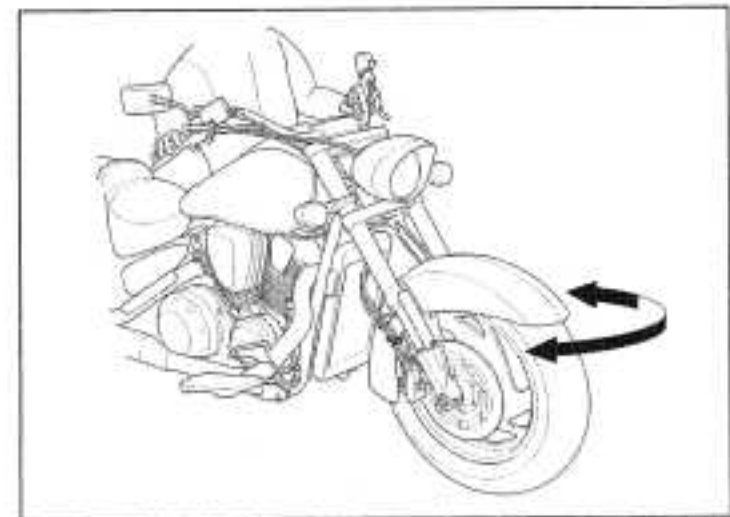

# LUBRICATION SYSTEM

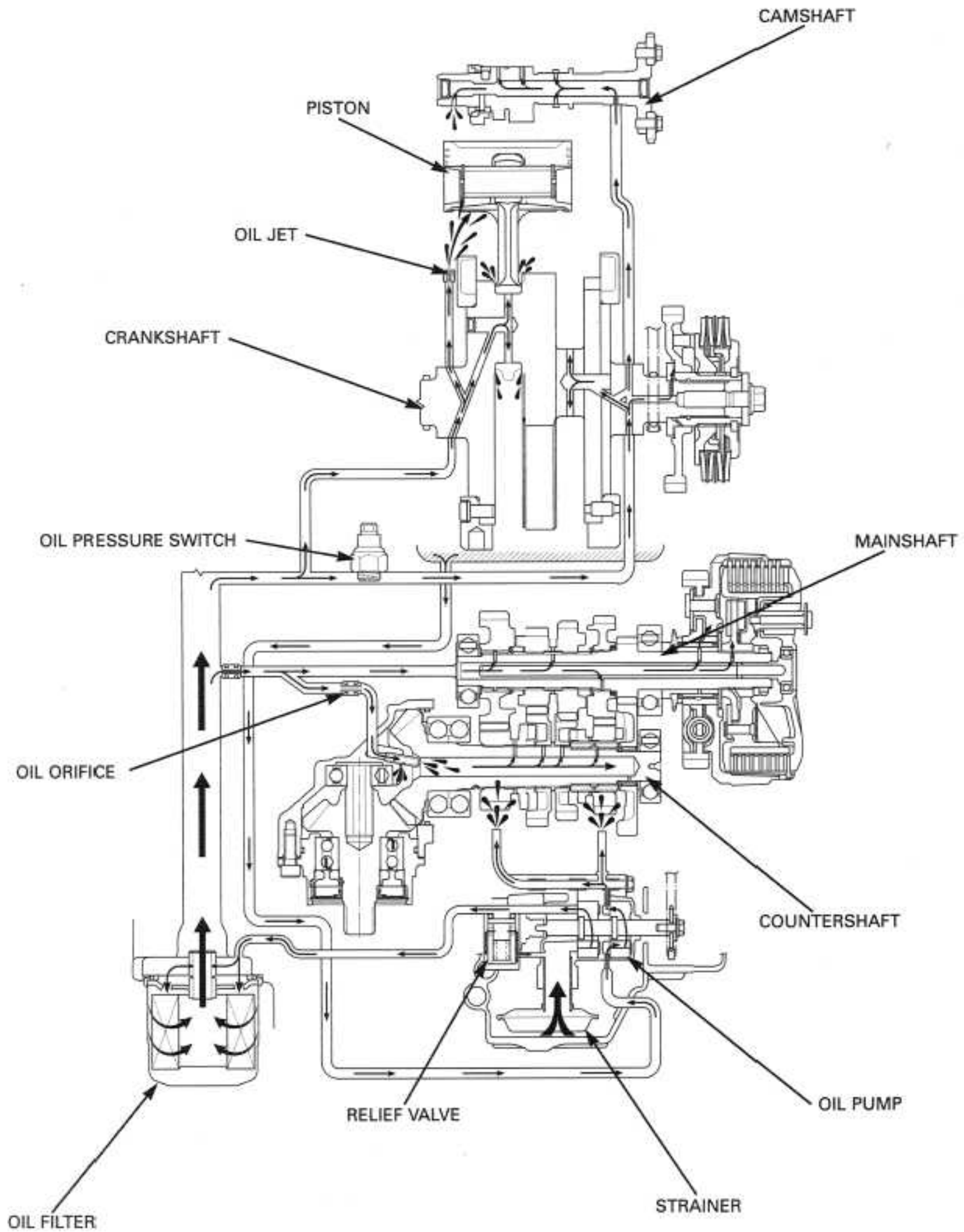



# 4. LUBRICATION SYSTEM

SERVICE INFORMATION	4-1	OIL PRESSURE CHECK	4-3
TROUBLESHOOTING	4-2	OIL PUMP & OIL STRAINER	4-3

## SERVICE INFORMATION

### GENERAL

#### ⚠ CAUTION

4

Used engine oil contains substances that have been identified as carcinogenic. If repeatedly left in contact with the skin for prolonged periods, it may cause skin cancer. Wash your hands thoroughly with soap and water as soon as possible after contact with used engine oil.

- The oil pump service requires engine removal and crankcase separation.
- When removing and installing the oil pump, use care not to allow dust or dirt to enter the engine.
- If any portion of the oil pump is worn beyond the specified service limits, replace the oil pump as an assembly.
- After the oil pump has been installed, check that there are no oil leaks and that oil pressure is correct.
- For oil pressure indicator inspection, refer to section 19 of this manual.

### SPECIFICATION

Unit: mm (in)

ITEM			STANDARD	SERVICE LIMIT
Engine oil capacity	After draining		3.5 liter (3.7 US qt, 3.1 Imp qt)	—
	After draining/filter change		3.7 liter (3.9 US qt, 3.3 Imp qt)	—
	After disassembly		4.5 liter (4.8 US qt, 4.0 Imp qt)	—
Recommended engine oil			Pro HONDA GN4 or HP4 4-stroke oil (U.S.A. and Canada) or Honda 4-stroke oil (Canada only), or equivalent motor oil API service classification SF or SG Viscosity: SAE 10W-40	—
Oil pressure at oil pressure switch			530 kPa (5.4 kgf/cm <sup>2</sup> , 77 psi) at 5,000 rpm/(80°C/176°F)	—
Oil pump rotor	Feed pump	Tip clearance	0.15 (0.006)	0.20 (0.008)
		Body clearance	0.15 – 0.21 (0.006 – 0.008)	0.35 (0.014)
		Side clearance	0.02 – 0.07 (0.001 – 0.003)	0.10 (0.004)
	Scavenge pump	Tip clearance	0.15 (0.006)	0.20 (0.008)
		Body clearance	0.15 – 0.21 (0.006 – 0.008)	0.35 (0.014)
		Side clearance	0.02 – 0.07 (0.001 – 0.003)	0.10 (0.004)

### TORQUE VALUES

Front oil drain bolt	29 N•m (3.0 kgf•m, 22 lbf•ft)	
Rear oil drain bolt	29 N•m (3.0 kgf•m, 22 lbf•ft)	
Oil pump assembly bolt	13 N•m (1.3 kgf•m, 9 lbf•ft)	Apply a locking agent to the threads.
Oil pump driven sprocket bolt	18 N•m (1.8 kgf•m, 13 lbf•ft)	
Oil strainer bolt	13 N•m (1.3 kgf•m, 9 lbf•ft)	
Oil filter boss	18 N•m (1.8 kgf•m, 13 lbf•ft)	Apply a locking agent to the threads.
Oil filter cartridge	26 N•m (2.7 kgf•m, 20 lbf•ft)	Apply oil to the threads and flange surface.
Oil pressure switch	12 N•m (1.2 kgf•m, 9 lbf•ft)	Apply sealant to the threads.
Oil pressure switch wire terminal screw	2 N•m (0.2 kgf•m, 1.4 lbf•ft)	

## LUBRICATION SYSTEM

---

### TOOLS

Oil pressure gauge  
Oil pressure gauge attachment

07506-3000001 or equivalent commercially available in U.S.A.  
07510-4220100 or equivalent commercially available in U.S.A.

### TROUBLESHOOTING

#### Oil level too low

- Oil consumption
- External oil leak
- Worn piston ring
- Improperly installed piston rings
- Worn cylinders
- Worn stem seals
- Worn valve guide

#### Low oil pressure

- Oil level low
- Clogged oil strainer
- Faulty oil pump
- Internal oil leak
- Incorrect oil being used
- Pressure relief valve stuck open
- Clogged oil filter screen

#### No oil pressure

- Oil level low
- Clogged oil strainer
- Broken oil pump drive chain
- Broken oil pump drive and/or driven sprocket
- Damaged oil pump
- Internal oil leak

#### High oil pressure

- Pressure relief valve stuck closed
- Clogged oil gallery or metering orifice
- Incorrect oil being used

#### Oil contamination

- Oil or filter not changed often enough
- Worn piston ring

#### Oil emulsification

- Blown cylinder head gasket
- Leaky coolant passage
- Entry of water

## OIL PRESSURE CHECK

If the engine is cold, the pressure reading will be abnormally high. Warm up the engine to normal operating temperature before starting this test.

Stop the engine.  
Remove the bolt and sealing washer.

Connect an oil pressure gauge attachment and gauge to the bolt hole.

**TOOLS:**

Oil pressure gauge attachment 07510-4220100  
Oil pressure gauge 07506-3000001  
or equivalent commercially available in U.S.A.

Check the oil level and add the recommended oil if necessary (page 3-12).

Start the engine and check the oil pressure at 5,000 rpm.

**OIL PRESSURE: 530 kPa (5.4 kgf/cm<sup>2</sup>, 77 psi)  
at 5,000 rpm (80 °C/176 °F)**

Stop the engine.

Replace the sealing washer with new ones.  
Install and tighten the bolt securely.

Start the engine.  
Check that the oil pressure indicator goes out after 1 or 2 seconds. If the oil pressure indicator stays on, stop the engine immediately and determine the cause (page 19-17).

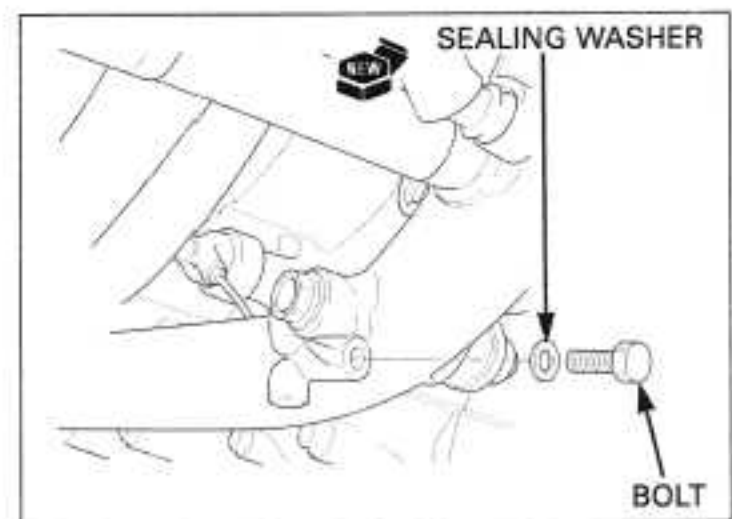
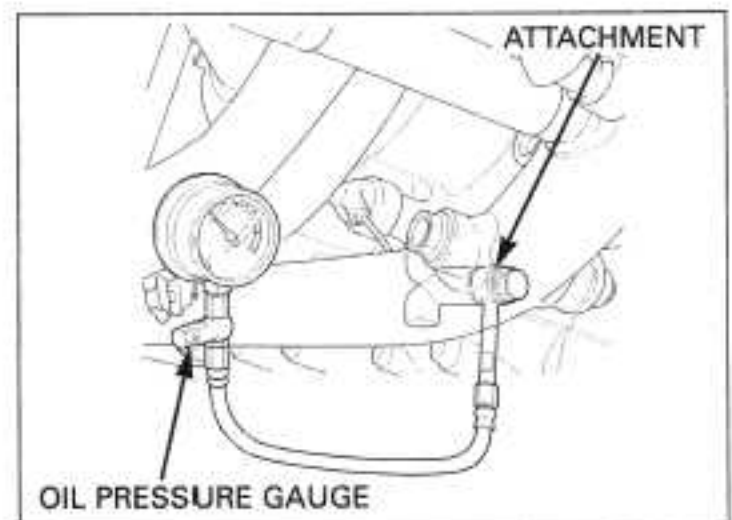
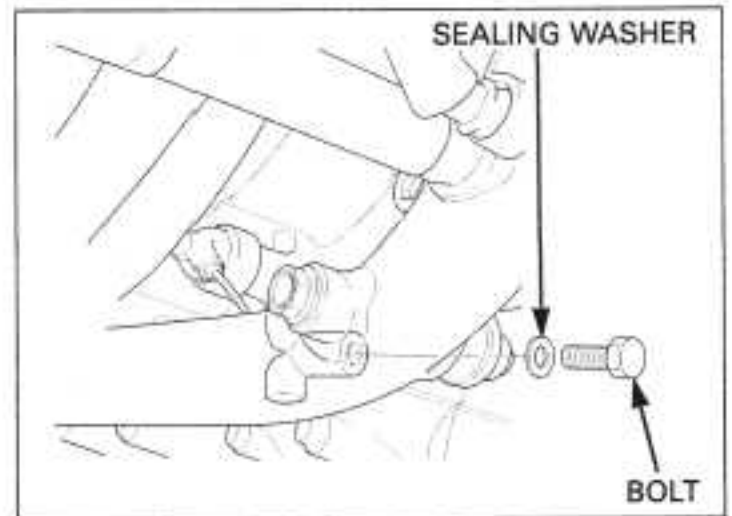

## OIL PUMP & STRAINER

### REMOVAL

Remove the engine from the frame (section 7).  
Separate the crankcase (page 11-4).

Remove the bolts and oil pump/strainer as an assembly.

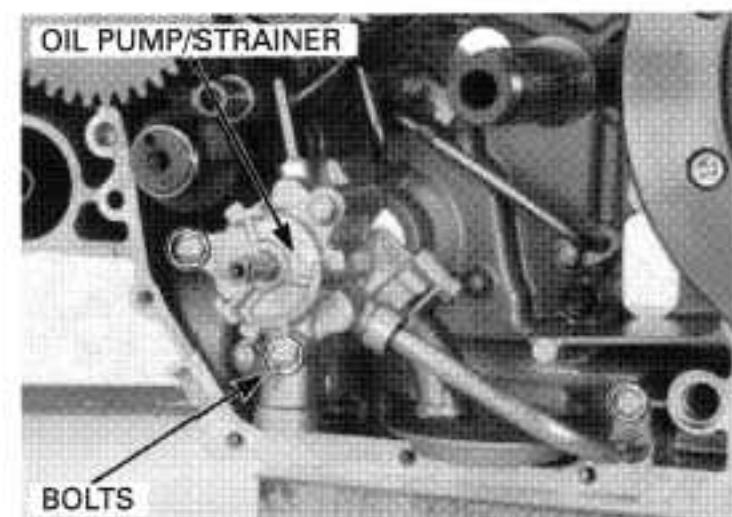

## LUBRICATION SYSTEM

---

Remove the dowel pin/O-ring and relief valve.

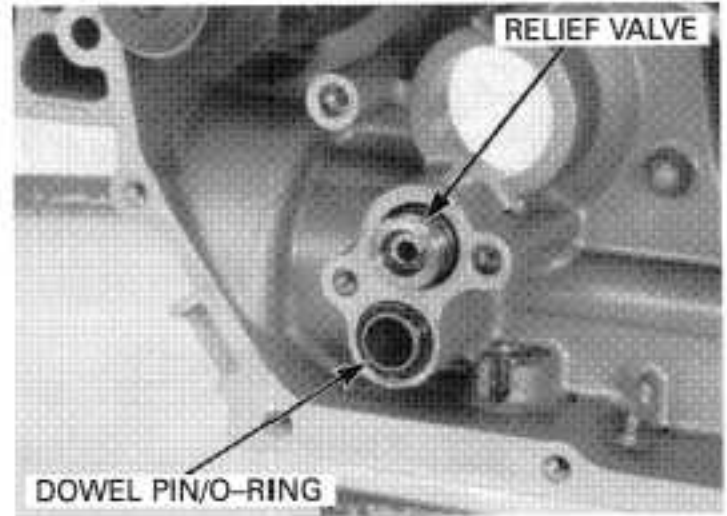

Remove the dowel pins and O-ring.

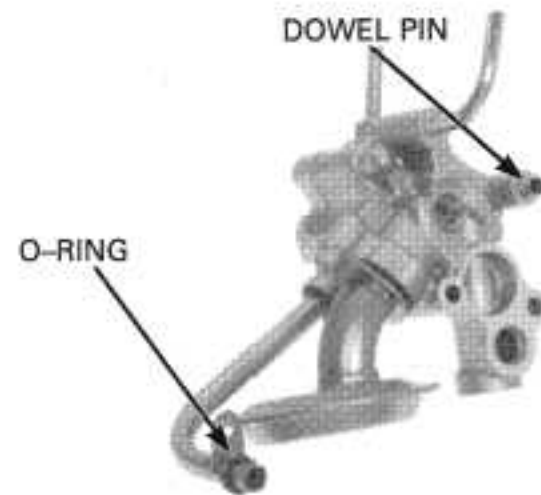

Remove the oil pipe and O-ring.

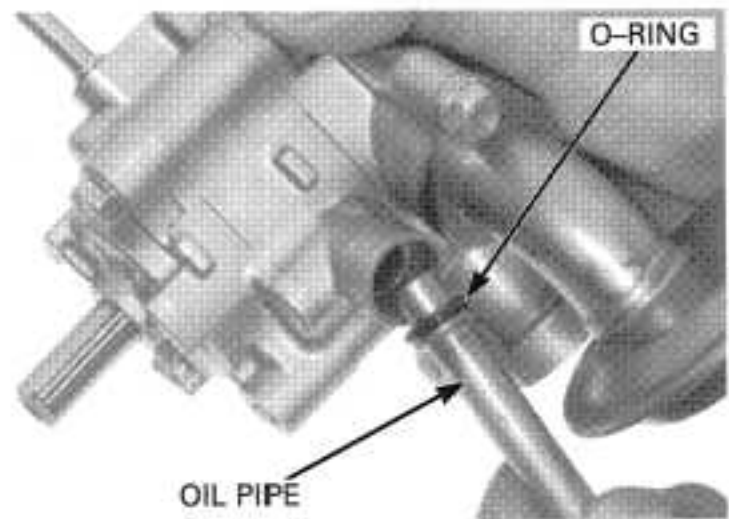

Remove the bolt and oil strainer/packing from the oil pump.

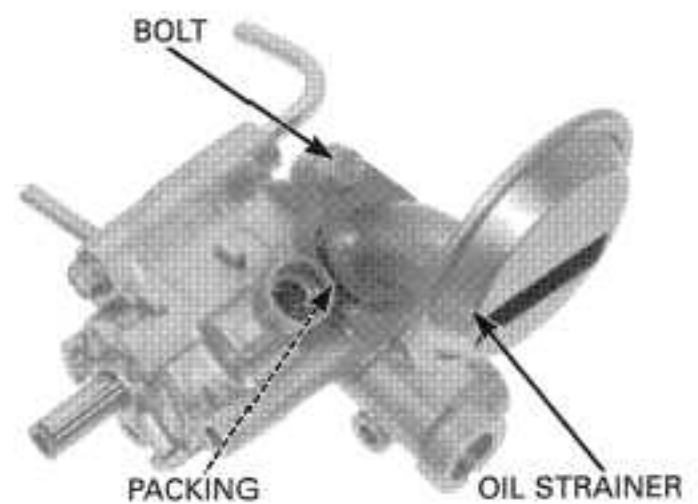



### RELIEF VALVE CHECK

Remove the O-ring from the relief valve groove.

Remove the snap ring and disassemble the relief valve.

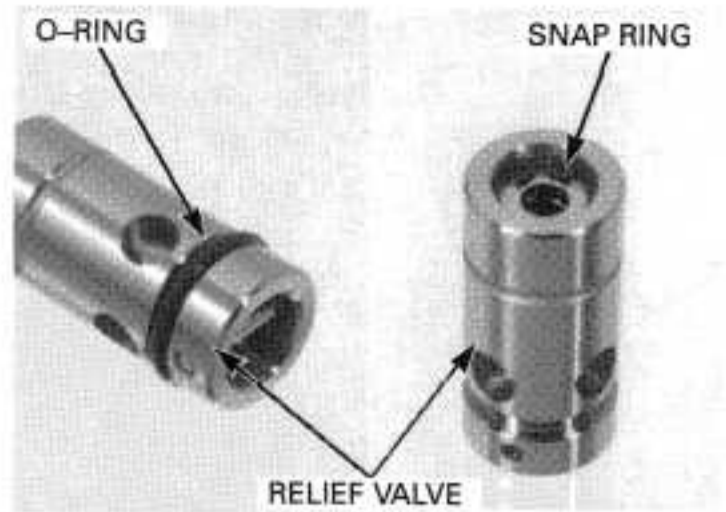

Check the spring and piston for wear or damage.  
Check the relief valve for clogs or damage.

Assemble the parts in the reverse order of disassembly.

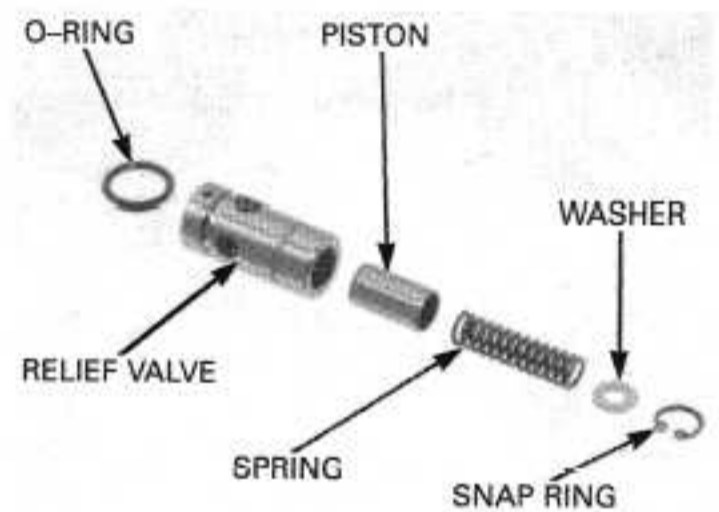

Be sure to use a new O-ring.

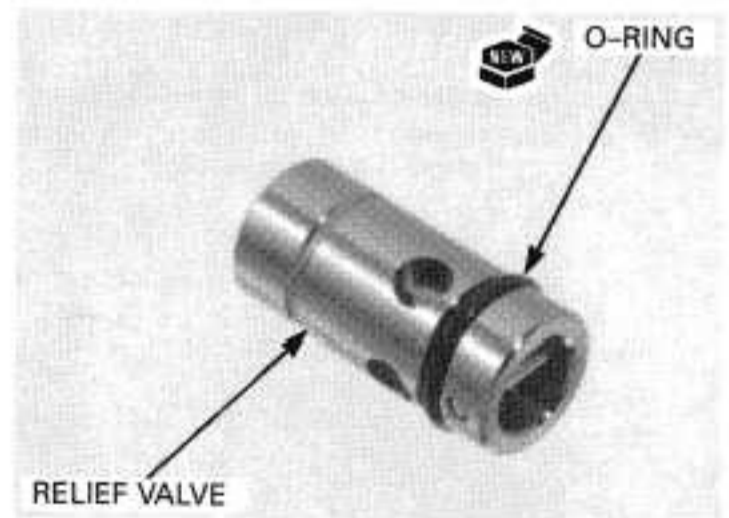

### OIL PIPE

Remove the bolts and oil pipe.

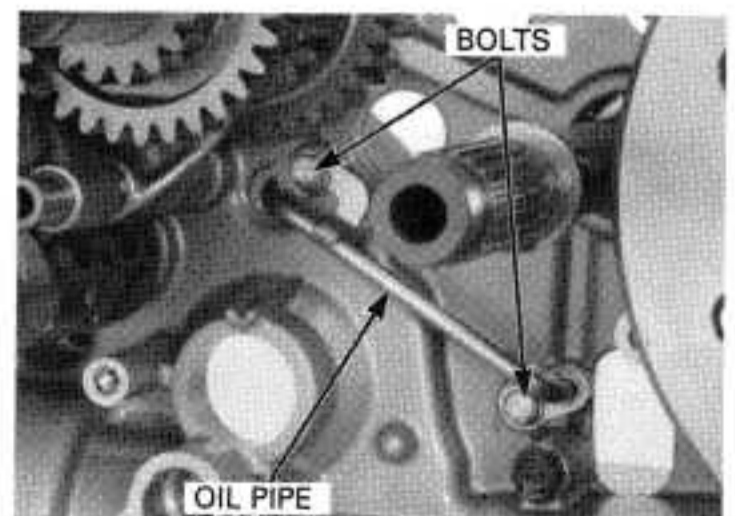

## LUBRICATION SYSTEM

Remove the O-rings from the oil pipe.

Installation is in the reverse order of removal.  
Be sure to use new O-rings.

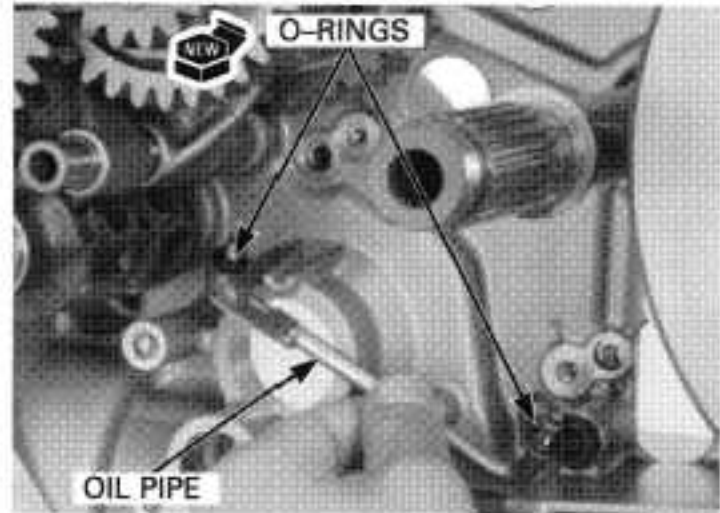

### DISASSEMBLY

Remove the oil pump assembly bolt.

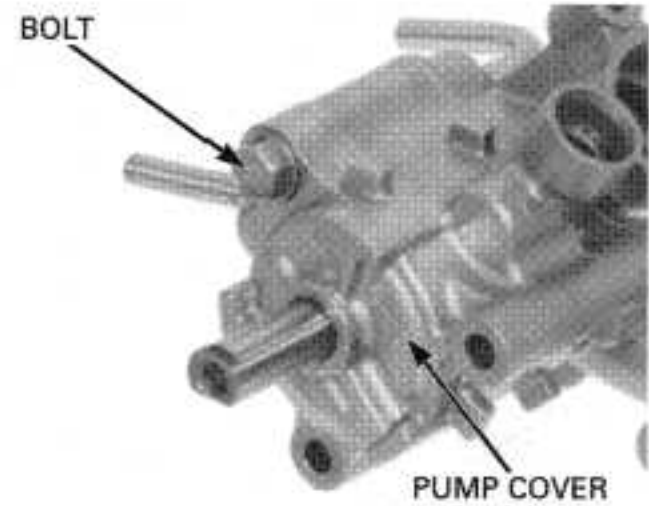

Remove the oil pump cover and dowel pins.

Remove the oil scavenge pump outer rotor and inner rotor.

Remove the drive pin.

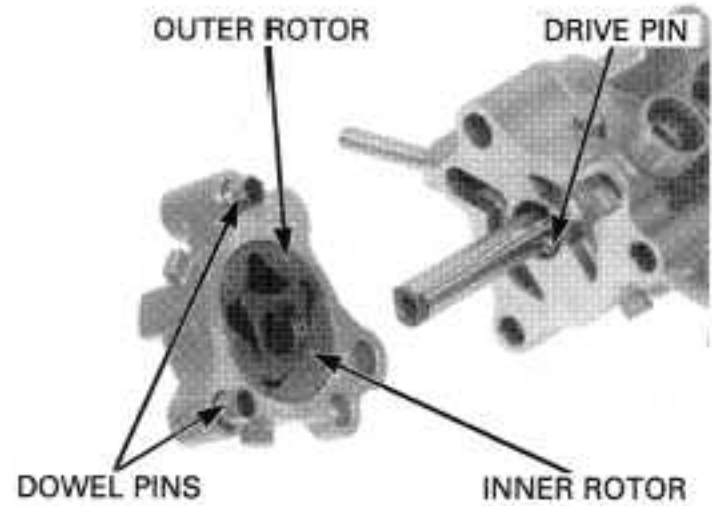

Remove the dowel pins, oil pump shaft, thrust washer, drive pin, feed pump outer rotor and inner rotor from the oil pump body.

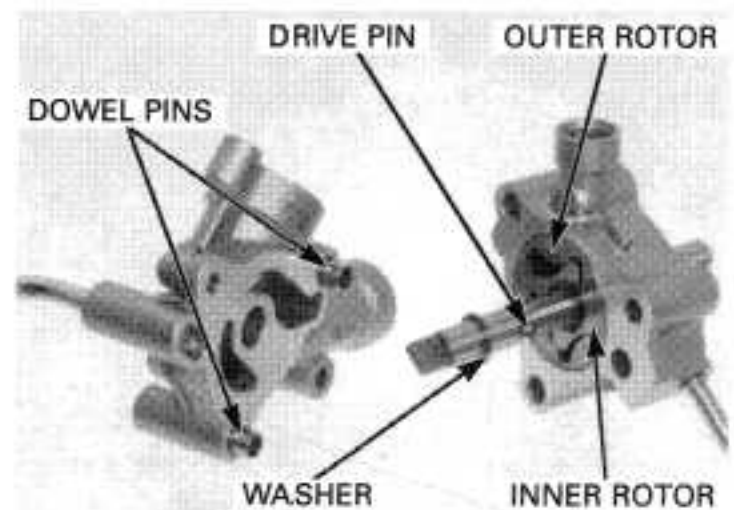

**INSPECTION**

Temporarily install the oil pump shaft.  
Install the outer and inner rotors into the oil pump body and oil pump cover.

Measure the tip clearance for the feed and scavenge pump.

**SERVICE LIMITS:**

- Feed pump: 0.20 mm (0.008 in)
- Scavenge pump: 0.20 mm (0.008 in)

FEED PUMP:

SCAVENGE PUMP:

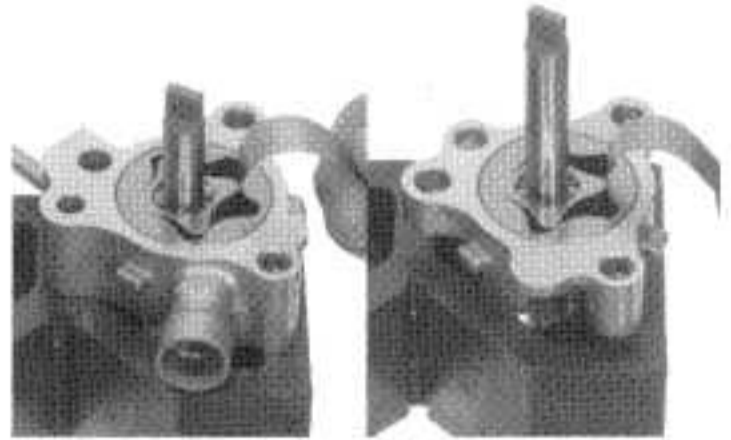

Measure the pump body clearance for the feed and scavenge pump.

**SERVICE LIMITS:**

- Feed pump: 0.35 mm (0.014 in)
- Scavenge pump: 0.35 mm (0.014 in)

FEED PUMP:

SCAVENGE PUMP:

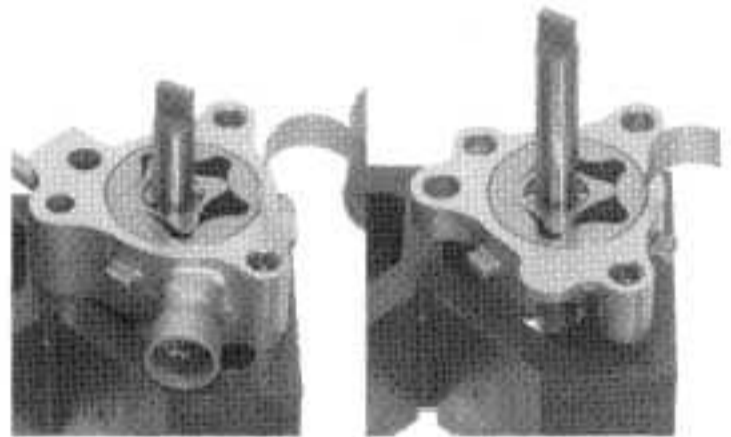

Measure the side clearance for the feed and scavenge pump using a straight edge and feeler gauge.

**SERVICE LIMITS:**

- Feed pump: 0.10 mm (0.004 in)
- Scavenge pump: 0.10 mm (0.004 in)

FEED PUMP:

SCAVENGE PUMP:

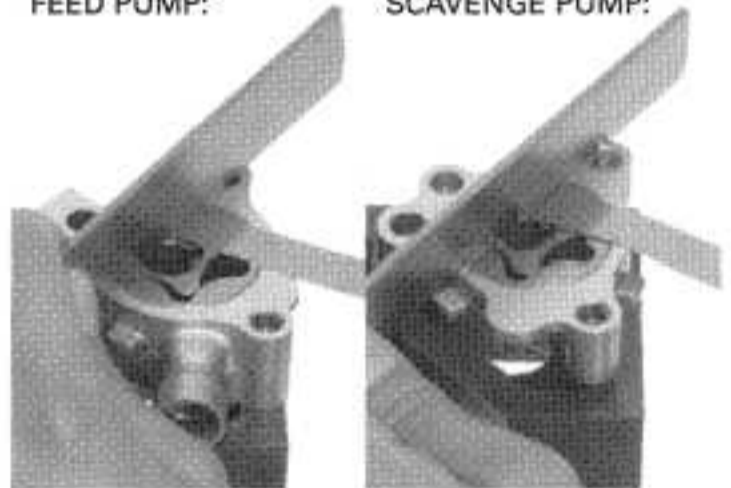

# LUBRICATION SYSTEM

## ASSEMBLY

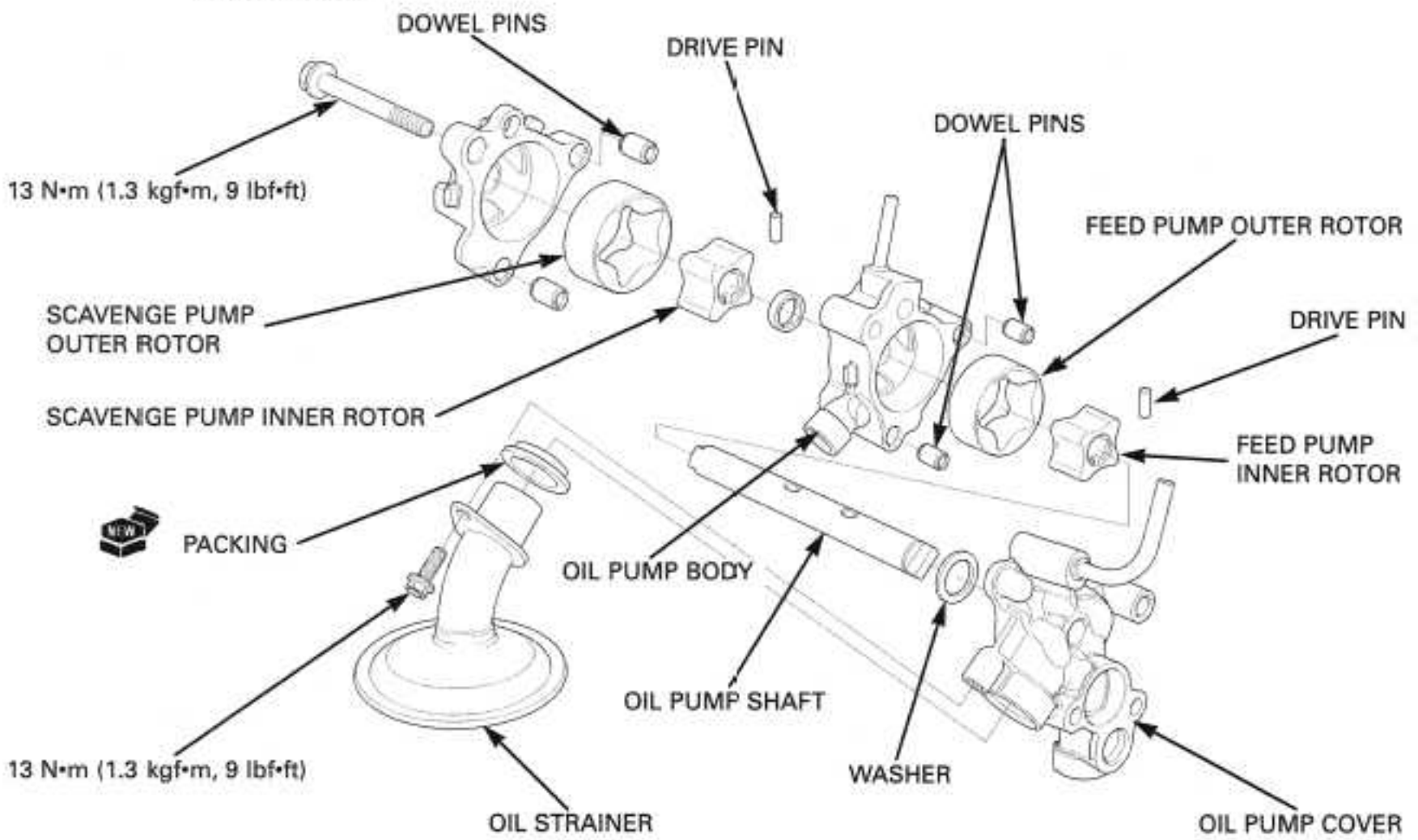

Install the feed pump outer and inner rotors onto the oil pump shaft.  
 Install the drive pin into the hole in the pump shaft and align the pin with the groove in the inner rotor as shown.  
 Install the thrust washer onto the shaft.  
 Install the oil pump shaft through the oil pump body.  
 Install the dowel pins.

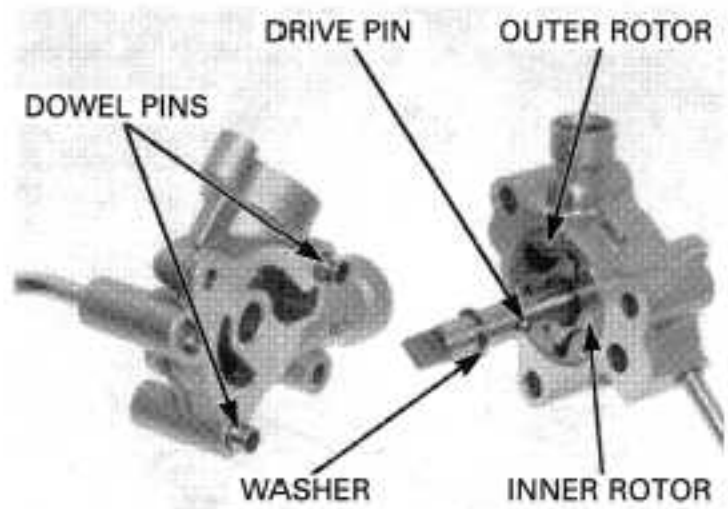

Install the drive pin into the hole in the pump shaft.  
 Install the scavenge pump outer and inner rotors into the oil pump cover.  
 Install the dowel pins.  
 Install the oil pump cover assembly onto the oil pump body.

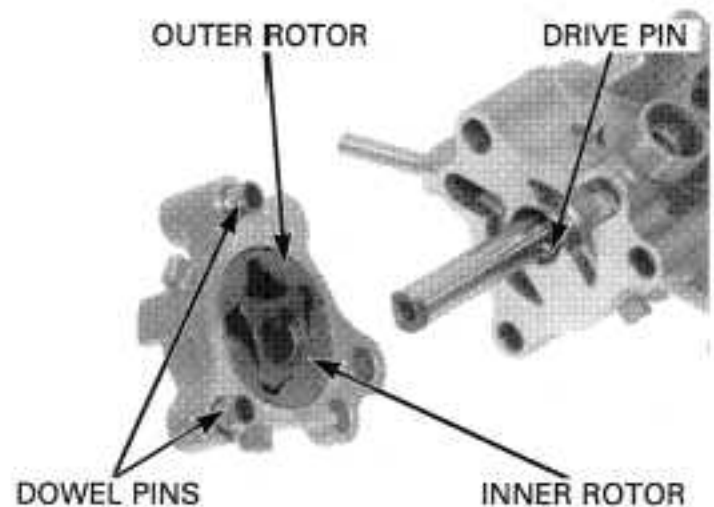



Install and tighten the assembly bolts to the specified torque.

**TORQUE: 13 N·m (1.3 kgf·m, 9 lbf·ft)**

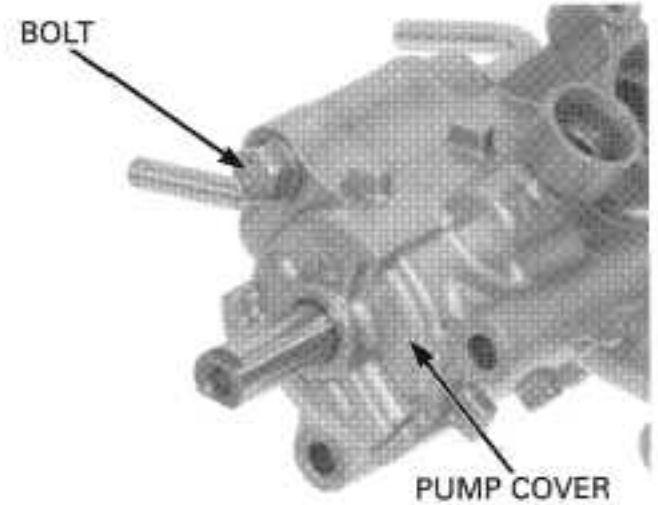

### INSTALLATION

Coat a new packing with engine oil and install it onto the oil strainer.  
Install the oil strainer into the oil pump.

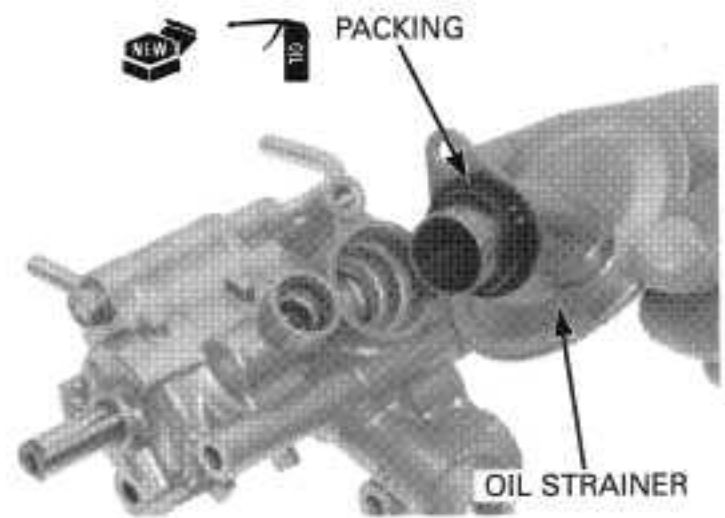

Install and tighten the bolt to the specified torque.

**TORQUE: 13 N·m (1.3 kgf·m, 9 lbf·ft)**

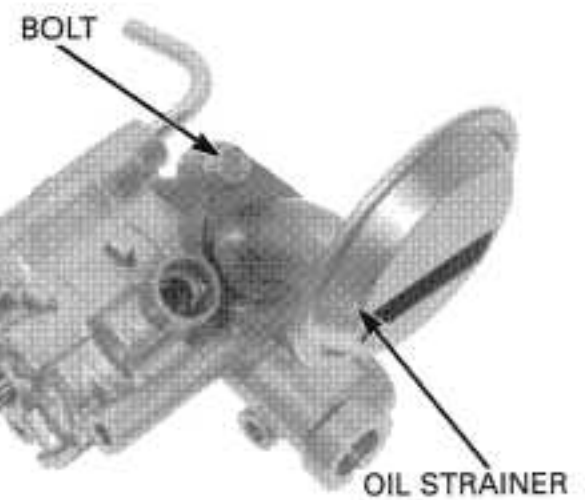

Coat a new O-ring with engine oil and install it to the oil pipe.  
Install the oil pipe into the oil pump.

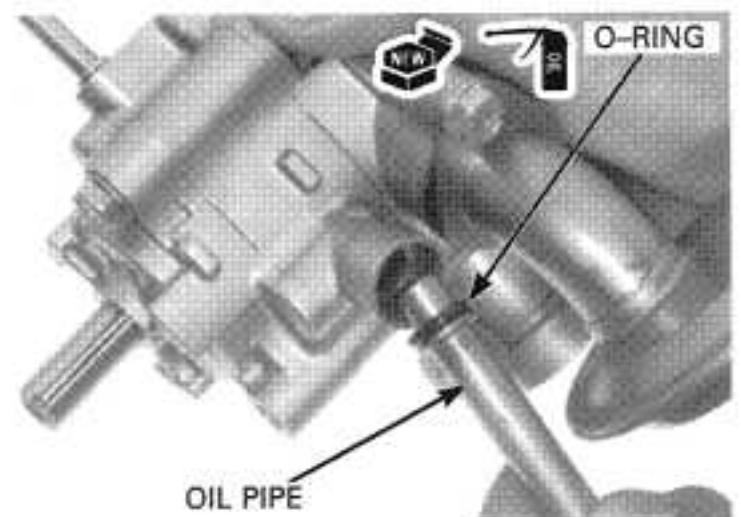

## LUBRICATION SYSTEM

---

Install the dowel pins into the oil pump.  
Coat a new O-ring with engine oil and install it to the oil pipe.

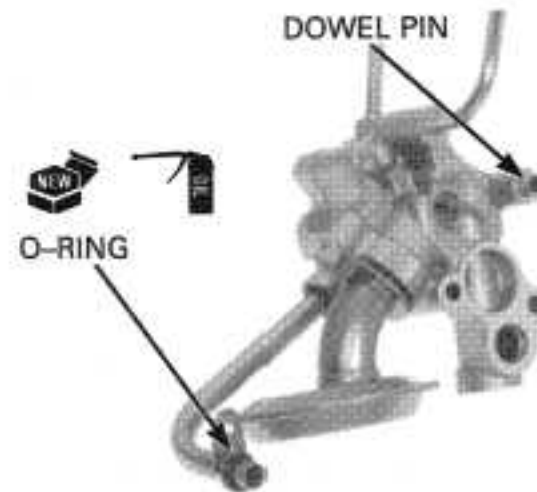

Coat a new O-ring with engine oil and install it to the dowel pin.  
Install the dowel pin/O-ring into the left crankcase.

Coat a new O-ring with engine oil and install the relief valve into the right crankcase.

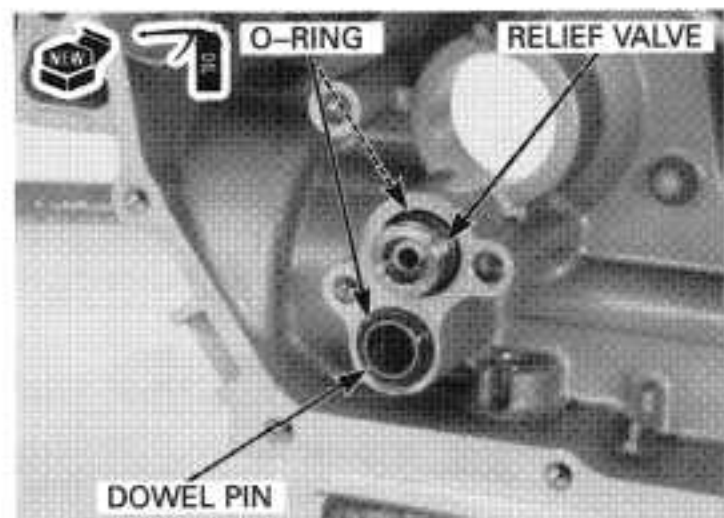

Install the oil pump/strainer to the left crankcase.

Install and tighten the oil pump mounting bolts securely.

Assemble the crankcase (page 11-17).  
Install the engine into the frame (section 7).

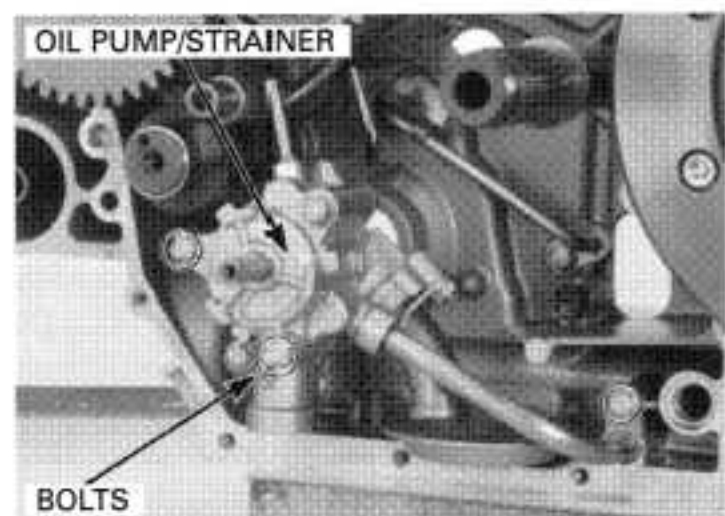

## FUEL SYSTEM (Programmed Fuel Injection)

---

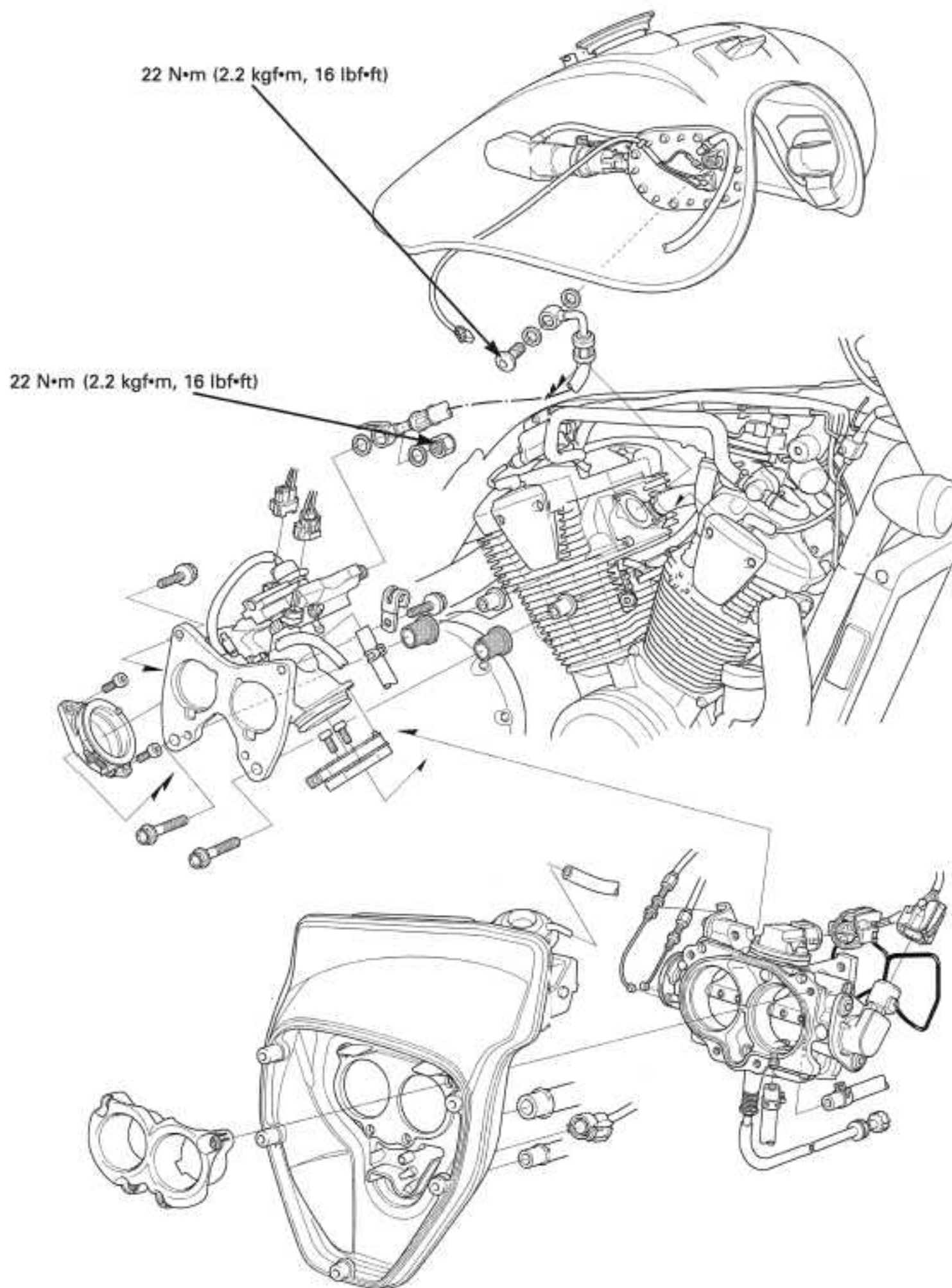

# 5. FUEL SYSTEM (Programmed Fuel Injection)

SERVICE INFORMATION	5-1	AIR SCREW SYNCHRONIZATION	5-72
TROUBLESHOOTING	5-3	BARO/MAP SENSOR	5-73
SYSTEM LOCATION	5-4	IAT SENSOR	5-74
SYSTEM DIAGRAM	5-5	ECT SENSOR	5-74
PGM-FI (PROGRAMMED FUEL INJECTION) SYSTEM	5-6	CAM PULSE GENERATOR	5-75
PGM-FI SELF-DIAGNOSIS MALFUNCTION INDICATOR FAILURE CODES	5-10	TP SENSOR	5-75
FUEL LINE INSPECTION	5-52	BANK ANGLE SENSOR	5-77
FUEL PUMP	5-54	ENGINE STOP RELAY	5-78
FUEL CUT-OFF RELAY	5-56	ECM (ENGINE CONTROL MODULE)	5-79
FUEL TANK	5-56	INTAKE DUCT CONTROL SOLENOID VALVE	5-79
AIR CLEANER HOUSING	5-57	PAIR SOLENOID VALVE	5-81
THROTTLE BODY	5-58	PAIR CHECK REED VALVE	5-82
INJECTORS	5-66	EVAP PURGE CONTROL VALVE (CALIFORNIA TYPE ONLY)	5-83
STARTER VALVE	5-70	O <sub>2</sub> SENSOR (CALIFORNIA TYPE ONLY)	5-84

## SERVICE INFORMATION

### GENERAL

- Be sure to relieve the fuel pressure with the ignition switch turned to "OFF".
- Bending or twisting the control cables will impair smooth operation and could cause the cables to stick or bind, resulting in loss of vehicle control.
- Work in a well ventilated area. Smoking or allowing flames or sparks in the work area or where gasoline is stored can cause a fire or explosion.
- Do not apply commercially available carburetor cleaners to the inside of the throttle bore, which is coated with molybdenum.
- Seal the cylinder head intake ports with tape or a clean cloth to keep dirt and debris from entering the intake ports after incorrect idle operation.
- Do not apply excessive force to the fuel pipe on the throttle body while removing or installing the throttle body.
- Do not damage the throttle body. It may cause incorrect air screw synchronization.
- Prevent dirt and debris from entering the throttle bore, fuel hose and return hose, clean them using compressed air.
- The throttle body is factory pre-set. Do not disassemble in a way other than shown in this manual.
- Do not loosen or tighten the white painted bolts and screws of the throttle body. Loosening or tightening them can cause throttle valve synchronization failure.
- Do not push the fuel pump base under the fuel tank when the fuel tank is stored.
- Always replace the packing when the fuel pump is removed.
- The programmed fuel injection system is equipped with the Self-Diagnostic System described on page 5-5. If the MIL blinks, follow the Self-Diagnostic Procedures to remedy the problem.
- When checking the PGM-FI, always follow the steps in the troubleshooting flow chart (page 5-10).
- The PGM-FI system is provided with a failsafe function to secure a minimum running capability even when there is no trouble in the system. When any abnormality is detected by the self-diagnosis function, running capability is secured by making use of the numerical values of a situation preset in advance in the simulated program map. It must be remembered, however, that when any abnormality is detected in four injectors and/or the ignition and cam pulse generator, the fail safe function stops the engine from the standpoint of protecting it.



## FUEL SYSTEM (Programmed Fuel Injection)

- For PGM-FI system component location, see page 5-4.
- A faulty PGM-FI system is often related to poorly connected or corroded connectors. Check those connections before proceeding.
- The vehicle speed sensor sends a digital pulse signal to the ECM (PGM-FI unit) and computation. For vehicle speed sensor inspection, see section 19.
- When disassembling the programmed fuel injection parts, note the location of the O-rings. Replace them with new ones upon reassembly.
- Before disconnecting the fuel hose, release the fuel pressure by loosening the fuel hose banjo bolt at the fuel tank.
- Always replace the sealing washers when the fuel hose banjo bolt is removed or loosened.
- Use a digital tester for PGM-FI system inspection.

### SPECIFICATIONS

ITEM	SPECIFICATIONS
Throttle body identification number	GQ42A
Idle speed	800 ± 100 rpm
Throttle grip free play	2 – 6 mm (1/16 – 1/4 in)
Intake air temperature sensor resistance (at 20°C/68°F)	1 – 4 kΩ
Engine coolant temperature sensor resistance (at 20°C/68°F)	2.3 – 2.6 kΩ
Fuel injector resistance (at 20°C/68°F)	13.4 – 14.2 Ω
PAIR solenoid valve resistance (at 20°C/68°F)	20 – 24 Ω
Cam pulse generator peak voltage (at 20°C/68°F)	0.7 V minimum
Ignition pulse generator peak voltage (at 20°C/68°F)	0.7 V minimum
Manifold absolute pressure at idle	290 mm Hg
Fuel pressure at idle	343 kPa (3.5 kgf/cm <sup>2</sup> , 50 psi)
Fuel pump flow (at 12 V)	188 cm <sup>3</sup> (6.4 US oz, 6.6 Imp oz) minimum/10 seconds

### TORQUE VALUES

Air cleaner housing cover bolt	3.4 N•m (0.35 kgf•m, 2.5 lbf•ft)	
Fuel tank rear mounting bolt	12 N•m (1.2 kgf•m, 9 lbf•ft)	U-nut
Fuel hose banjo bolt (fuel tank side)	22 N•m (2.2 kgf•m, 16 lbf•ft)	
Fuel hose sealing nut (throttle body side)	22 N•m (2.2 kgf•m, 16 lbf•ft)	
Fuel pump mounting nut	12 N•m (1.2 kgf•m, 9 lbf•ft)	
Starter valve screw	3.4 N•m (0.35 kgf•m, 2.5 lbf•ft)	
MAP sensor screw	2.1 N•m (0.21 kgf•m, 1.5 lbf•ft)	
Throttle cable guide screw	3.4 N•m (0.35 kgf•m, 2.5 lbf•ft)	
ECT sensor	18 N•m (1.8 kgf•m, 13 lbf•ft)	
O <sub>2</sub> sensor	24.5 N•m (2.5 kgf•m, 18 lbf•ft)	

### TOOLS

Fuel pressure gauge	07406-004000A
Pilot screw wrench	07908-4730002
Peak voltage tester or Peak voltage adapter	07HGJ-0020100 (not available in U.S.A.) with commercially available digital multi-meter (impedance 10MΩ/DCV minimum)
Vacuum gauge set	07LMJ-001000A
ECU test harness	07YMZ-0010100 (two required)

### TROUBLESHOOTING

#### Engine won't start

- Intake air leak
- Fuel contaminated/deteriorated
- Pinched or clogged fuel hose
- Faulty fuel pump
- Clogged fuel filter
- Clogged fuel injector filter
- Sticking fuel injector needle
- Faulty fuel pump operating system

#### Engine stalls, hard to start, or rough idling

- Intake air leak
- Fuel contaminated/deteriorated
- Pinched or clogged fuel hose
- Idle speed misadjusted
- Air screw synchronization misadjusted

#### Backfiring or misfiring during acceleration

- Ignition system malfunction

#### Poor performance (driveability) and poor fuel economy

- Pinched or clogged fuel hose

**SYSTEM LOCATION**

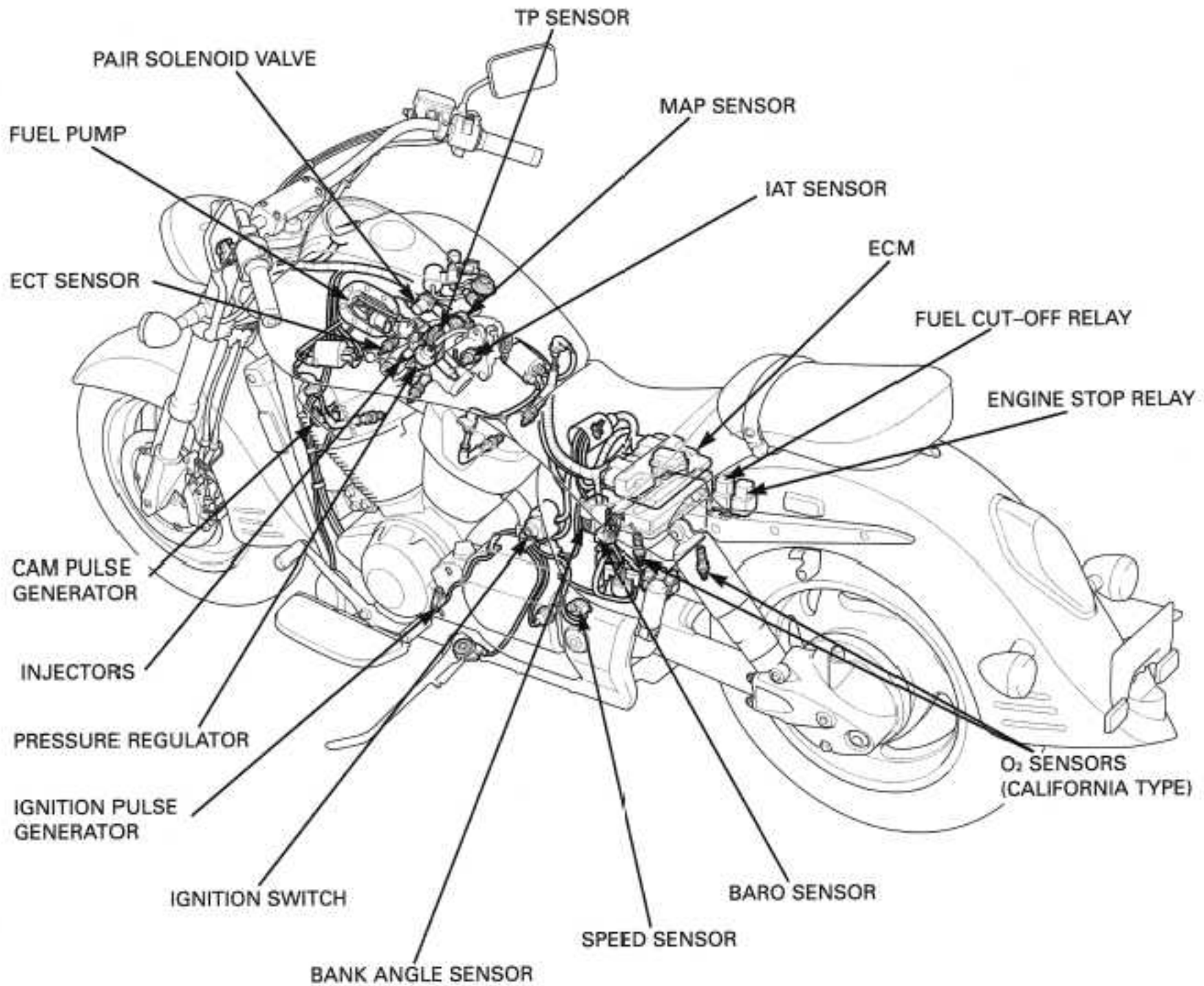

FULL NAME	ABBREVIATIONS
Manifold absolute pressure sensor	MAP sensor
Throttle position sensor	TP sensor
Intake air temperature sensor	IAT sensor
Engine coolant temperature sensor	ECT sensor
Engine control module	ECM

SYSTEM DIAGRAM

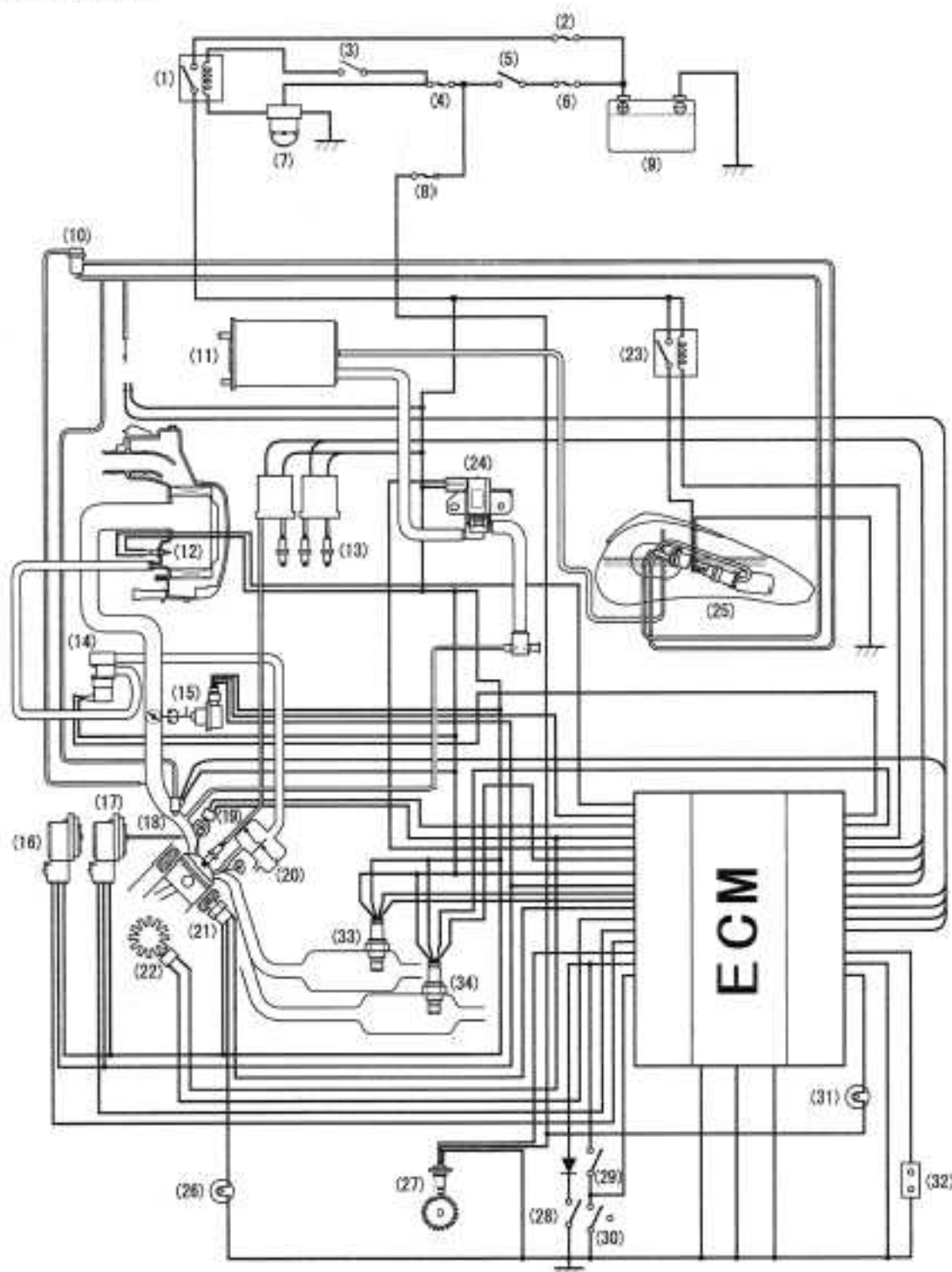

(1)	Engine stop relay	(18)	Injectors
(2)	PGM-FI fuse (30A)	(19)	Cam pulse generator
(3)	Engine stop switch	(20)	PAIR check valve
(4)	Sub-fuse (10A)	(21)	ECT sensor
(5)	Ignition switch	(22)	Ignition pulse generator
(6)	Main fuse A (30A)	(23)	Fuel cut-off relay
(7)	Bank angle sensor	(24)	EVAP purge control solenoid valve (California type)
(8)	Sub-fuse (10A)	(25)	Fuel pump
(9)	Battery	(26)	Coolant temperature indicator
(10)	Pressure regulator	(27)	Speed sensor
(11)	EVAP canister (California type)	(28)	Neutral switch
(12)	IAT sensor	(29)	Clutch switch
(13)	Spark plug	(30)	Side stand switch
(14)	PAIR solenoid valve	(31)	Malfunction indicator lamp (MIL)
(15)	TP sensor	(32)	Service check connector
(16)	MAP sensor	(33)	Front O <sub>2</sub> sensor (California type)
(17)	BARO sensor	(34)	Rear O <sub>2</sub> sensor (California type)



**PGM-FI (PROGRAMMED FUEL INJECTION) SYSTEM**

**SELF-DIAGNOSTIC PROCEDURE**

Place the motorcycle on its side stand.  
Start the engine and let it idle.

*The malfunction indicator will start blinking only with the side stand down and with the engine off (engine stop switch turned to "O") or engine speed below 5,000 rpm. In any other condition, the malfunction indicator will illuminate and stay on.*

If the malfunction indicator lamp (MIL) does not light or blink, the system has no memory of problem data. If the MIL blinks, note how many times it blinks, and determine the cause of the problem (page 5-10 through 5-51).

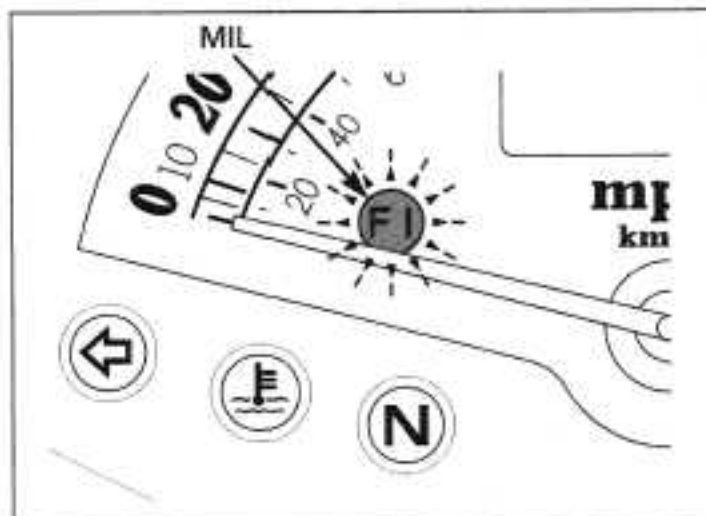

If you wish to read the PGM-FI memory for trouble data, perform the following:

Turn the ignition switch to "OFF".

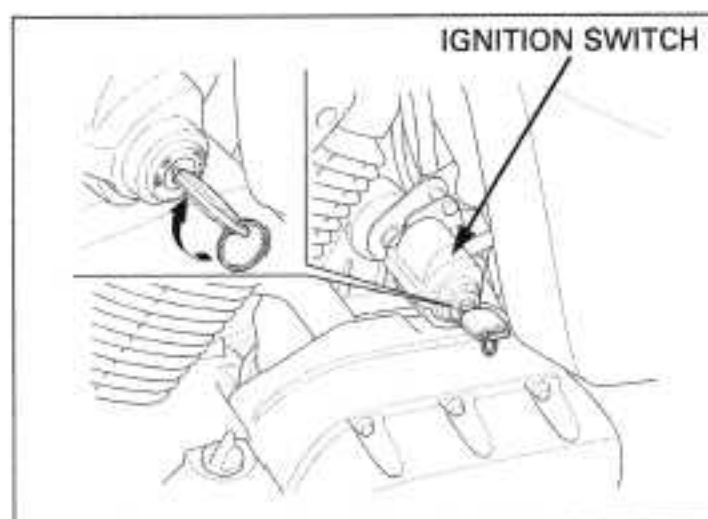

Remove the seat (page 2-2).

Short the PGM-FI system service check connector terminals using a jumper wire.

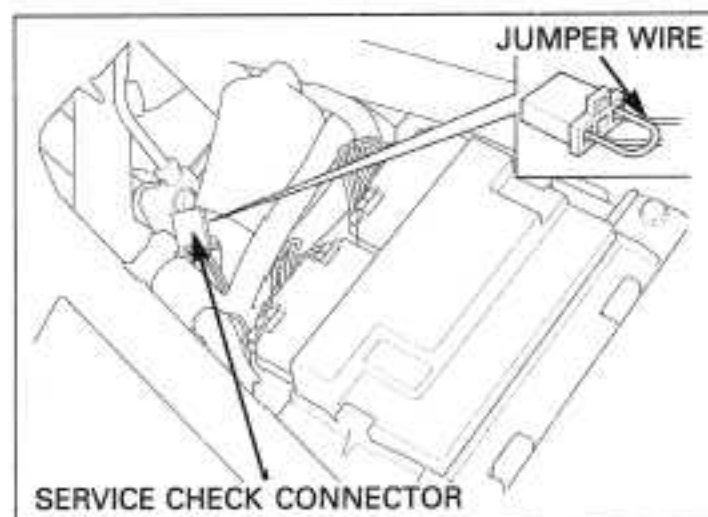

Turn the ignition switch to "ON" and engine stop switch to "O".

If the ECM has no self diagnosis memory data, the malfunction indicator will illuminate when you turn the ignition switch to "ON".

*Even if the PGM-FI has memory data, the malfunction indicator does not blink when the engine is running.*

If the ECM has self diagnosis memory data, the malfunction indicator will start blinking when you turn the ignition switch to "ON".

Note how many times the MIL blinks, and determine the cause of the problem (page 5-10 through 5-51).

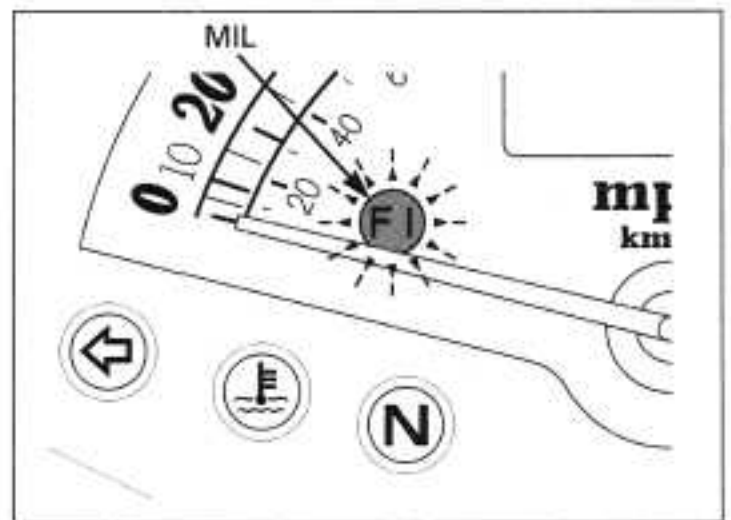
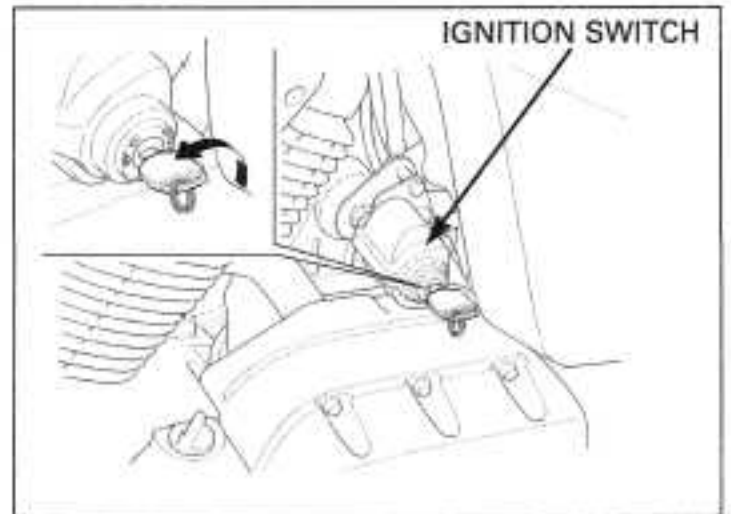

### SELF-DIAGNOSIS RESET PROCEDURE

1. Turn the engine stop switch to "O" and ignition switch to "OFF".
2. Short the service check connector of the PGM-FI system using a jumper wire.
3. Turn the ignition switch to "ON".
4. Remove the jumper wire from the service check connector.
5. The MIL lights for about 5 seconds.  
While the MIL lights, short the service check connector again with the jumper wire.  
Self diagnosis memory data is erased, if the malfunction indicator turns off and starts blinking.

- The service check connector must be jumped while the MIL lights. If not, the MIL will not start blinking.
- Note that the self diagnosis memory data cannot be erased if you turn off the ignition switch before the MIL starts blinking.

If the MIL blinks 20 times, the data has not been erased, perform the procedure again.

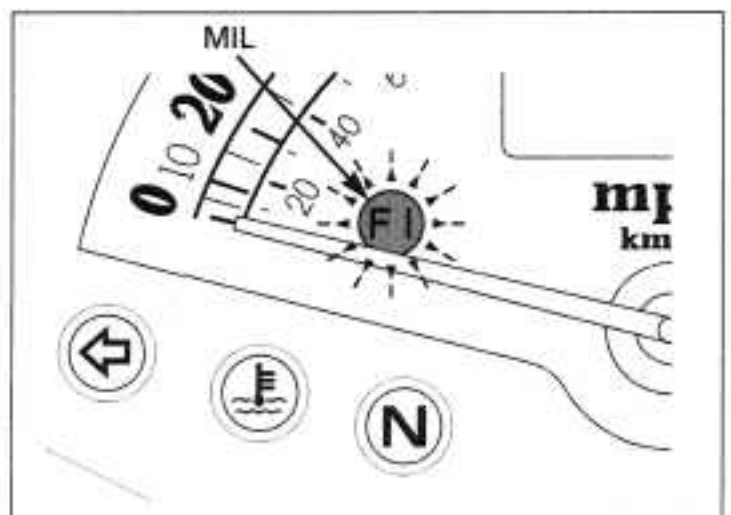
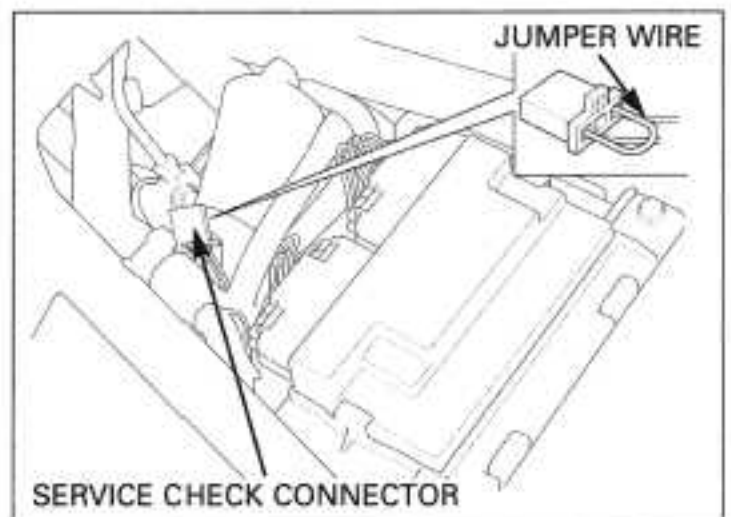

## FUEL SYSTEM (Programmed Fuel Injection)

### PEAK VOLTAGE INSPECTION PROCEDURE

- Use this procedure for the ignition pulse generator and cam pulse generator inspection.
- Check all system connections before inspection. If the system is disconnected, incorrect peak voltage might be measured.
- Check cylinder compression and check that all spark plugs are installed correctly.
- Use the recommended digital multimeter or a commercially available digital multimeter with an impedance of 10 M $\Omega$ /DCV minimum.
- The display value differs depending upon the internal impedance of the multimeter.
- Disconnect the fuel pump connector before checking the peak voltage.

Open and support the rear end of the fuel tank (page 3-4).

Disconnect the fuel pump 3P black connector.

Connect the peak voltage adaptor to the digital multimeter.

#### TOOLS:

Peak voltage tester (U.S.A. only) or  
Peak voltage adaptor 07HGJ-0020100  
(not available in  
U.S.A.)

With commercially available digital multimeter  
(impedance 10 M $\Omega$ /DCV minimum)

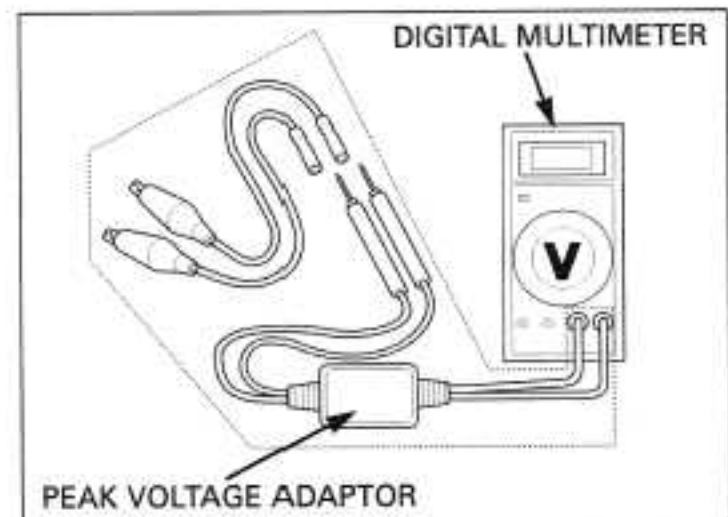
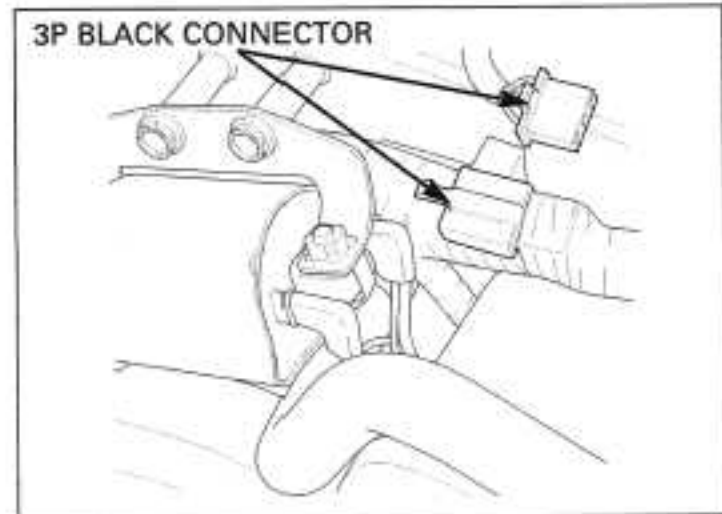

*Avoid touching  
the tester probes  
to prevent electric  
shock.*

### TEST HARNESS CONNECTION

Remove the seat (page 2-2).

Disconnect the ECM 22P black and 22P gray connectors from the unit.

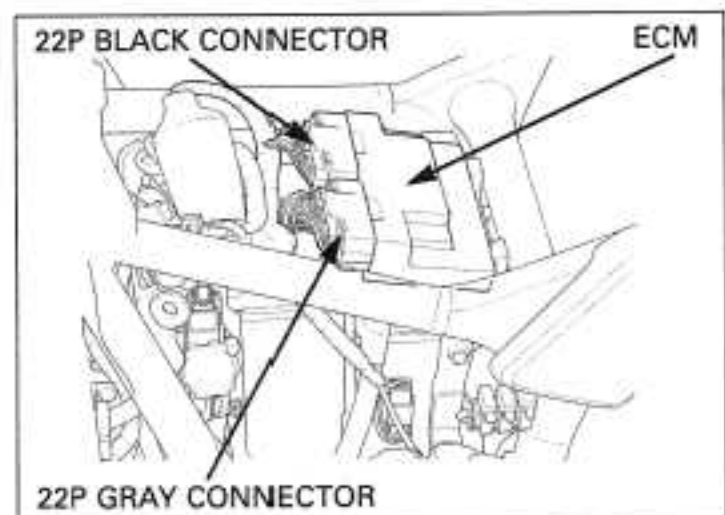

Connect the ECU test harness between the main wire harness and the ECM.

**TOOL:**  
**ECU test harness**

**07YMZ-0010100**  
**(two required)**

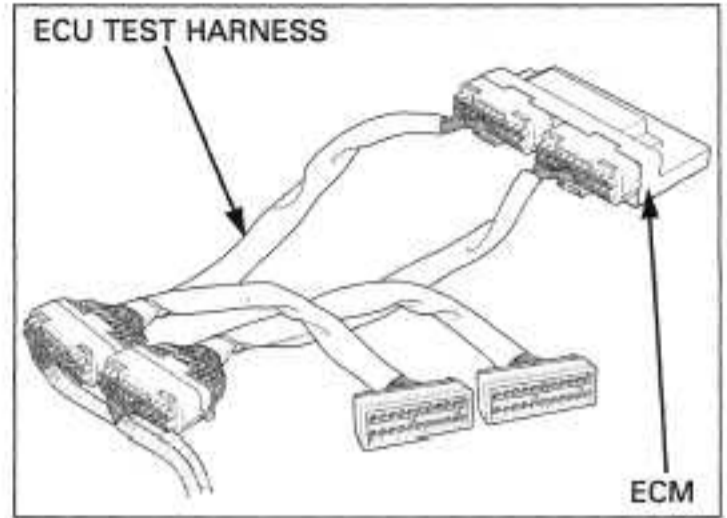

**TEST HARNESS TERMINAL LAYOUT**

The ECM connector terminals are numbered as shown in the illustration.

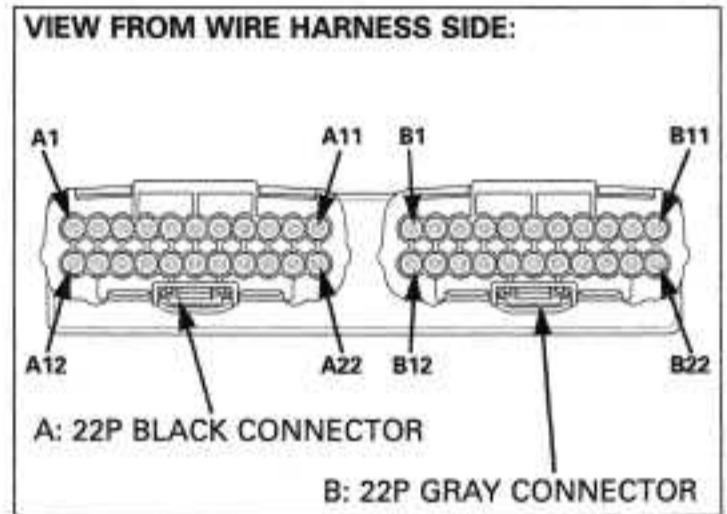



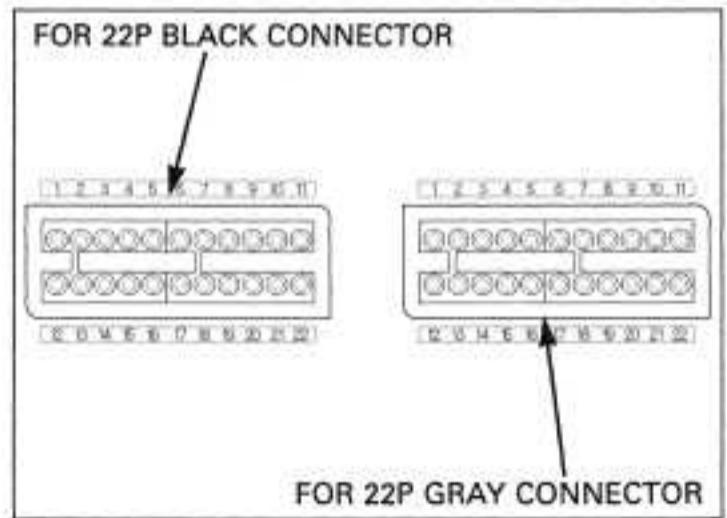





The test harness terminals are the same layout as for the ECM connector terminals as shown.















### PGM-FI SELF-DIAGNOSIS MALFUNCTION INDICATOR FAILURE CODES

- The PGM-FI malfunction indicator lamp (MIL) denotes the failure codes (the number of blinks from 0 to 33). The MIL has two types of blinks, a long blink and short blink. The long blink lasts for 1.3 seconds, the short blink lasts for 0.5 seconds. When a long blink occurs, that counts for 10 blinks of the MIL. The short blink counts for one MIL blink. Therefore, if the MIL blinks two long blinks, and one short blink, that problem code is 21 (two long blinks = 20 blinks, one short blink = 1 blink). Then, go to the flow chart and see problem code 21.
- When the Engine Control Module (ECM) stores some failure codes, the MIL shows the failure codes in the order from the lowest number to highest number. For example, when the MIL blinks once, then blinks seven times, two failures have occurred. Follow the flow charts for failure codes 1 and 7.

Number of PGM-FI MIL blinks	Causes	Symptoms (fail-safe contents)	Refer to page
0	 No blinks <ul style="list-style-type: none"> <li>• Open circuit at the power input wire of the ECM</li> <li>• Faulty bank angle sensor</li> <li>• Open circuit in bank angle sensor related circuit</li> <li>• Faulty engine stop relay</li> <li>• Open circuit in engine stop relay related wires</li> <li>• Faulty engine stop switch</li> <li>• Open circuit in engine stop switch related wires</li> <li>• Faulty ignition switch</li> <li>• Faulty ECM</li> <li>• Blown PGM-FI fuse (30 A)</li> <li>• Open circuit in engine stop switch ground</li> <li>• Blown sub-fuse (10 A) (Starter/ignition)</li> </ul>	<ul style="list-style-type: none"> <li>• Engine does not start</li> </ul>	—
	 No blinks <ul style="list-style-type: none"> <li>• Open or short circuit in MIL wire</li> <li>• Faulty ECM</li> </ul>	<ul style="list-style-type: none"> <li>• Engine operates normally</li> </ul>	—
	 Stays lit <ul style="list-style-type: none"> <li>• Short circuit in service check connector</li> <li>• Faulty ECM</li> <li>• Short circuit in service check connector wire</li> </ul>	<ul style="list-style-type: none"> <li>• Engine operates normally</li> </ul>	—
1	 Blinks <ul style="list-style-type: none"> <li>• Loose or poor contacts on MAP sensor connector</li> <li>• Open or short circuit in MAP sensor wire</li> <li>• Faulty MAP sensor</li> </ul>	<ul style="list-style-type: none"> <li>• Engine operates normally</li> </ul>	5-12
2	 Blinks <ul style="list-style-type: none"> <li>• Loose or poor connection of the MAP sensor vacuum hose</li> <li>• Faulty MAP sensor</li> </ul>	<ul style="list-style-type: none"> <li>• Engine operates normally</li> </ul>	5-14
7	 Blinks <ul style="list-style-type: none"> <li>• Loose or poor contact on ECT sensor</li> <li>• Open or short circuit in ECT sensor wire</li> <li>• Faulty ECT sensor</li> </ul>	<ul style="list-style-type: none"> <li>• Hard start at low temperature (Simulate using numerical values; 90°C/194°F)</li> </ul>	5-16
8	 Blinks <ul style="list-style-type: none"> <li>• Loose or poor contact on TP sensor connector</li> <li>• Open or short circuit in TP sensor wire</li> <li>• Faulty TP sensor</li> </ul>	<ul style="list-style-type: none"> <li>• Poor engine response when operating the throttle quickly (Simulate using numerical values; Throttle opens 0°)</li> </ul>	5-18
9	 Blinks <ul style="list-style-type: none"> <li>• Loose or poor contact on IAT sensor</li> <li>• Open or short circuit in IAT sensor wire</li> <li>• Faulty IAT sensor</li> </ul>	<ul style="list-style-type: none"> <li>• Engine operates normally (Simulate using numerical values; 25°C/77°F)</li> </ul>	5-22

## FUEL SYSTEM (Programmed Fuel Injection)

Number of PGM-FI malfunction indicator blinks		Causes	Symptoms (fail-safe contents)	Refer to page
10	 Blinks	<ul style="list-style-type: none"> <li>Loose or poor contacts on BARO sensor connector</li> <li>Open or short circuit in BARO sensor wire</li> <li>Faulty BARO sensor</li> </ul>	<ul style="list-style-type: none"> <li>Engine operates normally</li> </ul>	5-24
11	 Blinks	<ul style="list-style-type: none"> <li>Loose or poor contact on vehicle speed sensor connector</li> <li>Open or short circuit in vehicle speed sensor connector</li> <li>Faulty vehicle speed sensor</li> </ul>	<ul style="list-style-type: none"> <li>Engine operates normally</li> </ul>	5-26
12	 Blinks	<ul style="list-style-type: none"> <li>Loose or poor contact on rear injector connector</li> <li>Open or short circuit in rear injector wire</li> <li>Faulty rear injector</li> </ul>	<ul style="list-style-type: none"> <li>Engine does not start</li> </ul>	5-28
13	 Blinks	<ul style="list-style-type: none"> <li>Loose or poor contact on front injector connector</li> <li>Open or short circuit in front injector wire</li> <li>Faulty front injector</li> </ul>	<ul style="list-style-type: none"> <li>Engine does not start</li> </ul>	5-31
18	 Blinks	<ul style="list-style-type: none"> <li>Loose or poor contact on cam pulse generator</li> <li>Open or short circuit in cam pulse generator</li> <li>Faulty cam pulse generator</li> </ul>	<ul style="list-style-type: none"> <li>Engine does not start</li> </ul>	5-34
19	 Blinks	<ul style="list-style-type: none"> <li>Loose or poor contact on ignition pulse generator connector</li> <li>Open or short circuit in ignition pulse generator</li> <li>Faulty ignition pulse generator</li> </ul>	<ul style="list-style-type: none"> <li>Engine does not start</li> </ul>	5-36
21	 Blinks	<ul style="list-style-type: none"> <li>Faulty rear O<sub>2</sub> sensor</li> </ul>	<ul style="list-style-type: none"> <li>Engine operates normally</li> </ul>	5-38
22	 Blinks	<ul style="list-style-type: none"> <li>Faulty front O<sub>2</sub> sensor</li> </ul>	<ul style="list-style-type: none"> <li>Engine operates normally</li> </ul>	5-40
23	 Blinks	<ul style="list-style-type: none"> <li>Faulty rear O<sub>2</sub> sensor heater</li> </ul>	<ul style="list-style-type: none"> <li>Engine operates normally</li> </ul>	5-42
24	 Blinks	<ul style="list-style-type: none"> <li>Faulty front O<sub>2</sub> sensor heater</li> </ul>	<ul style="list-style-type: none"> <li>Engine operates normally</li> </ul>	5-46
33	 Blinks	<ul style="list-style-type: none"> <li>Faulty E<sup>2</sup>-PROM in ECM</li> </ul>	<ul style="list-style-type: none"> <li>Engine operates normally</li> <li>Does not hold the self-diagnosis data</li> </ul>	5-50

## FUEL SYSTEM (Programmed Fuel Injection)

### PGM-FI MIL 1 BLINK (MAP SENSOR)

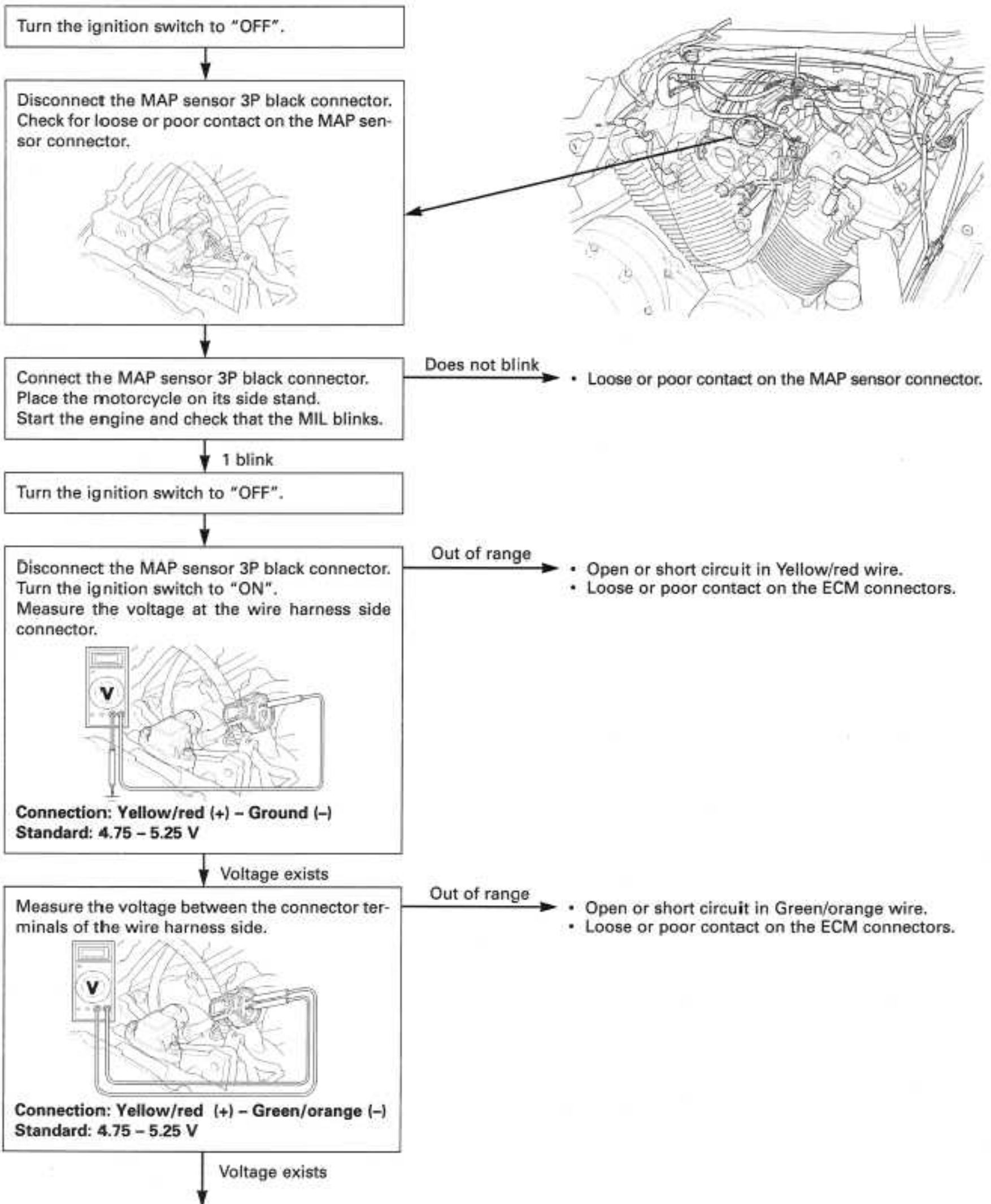

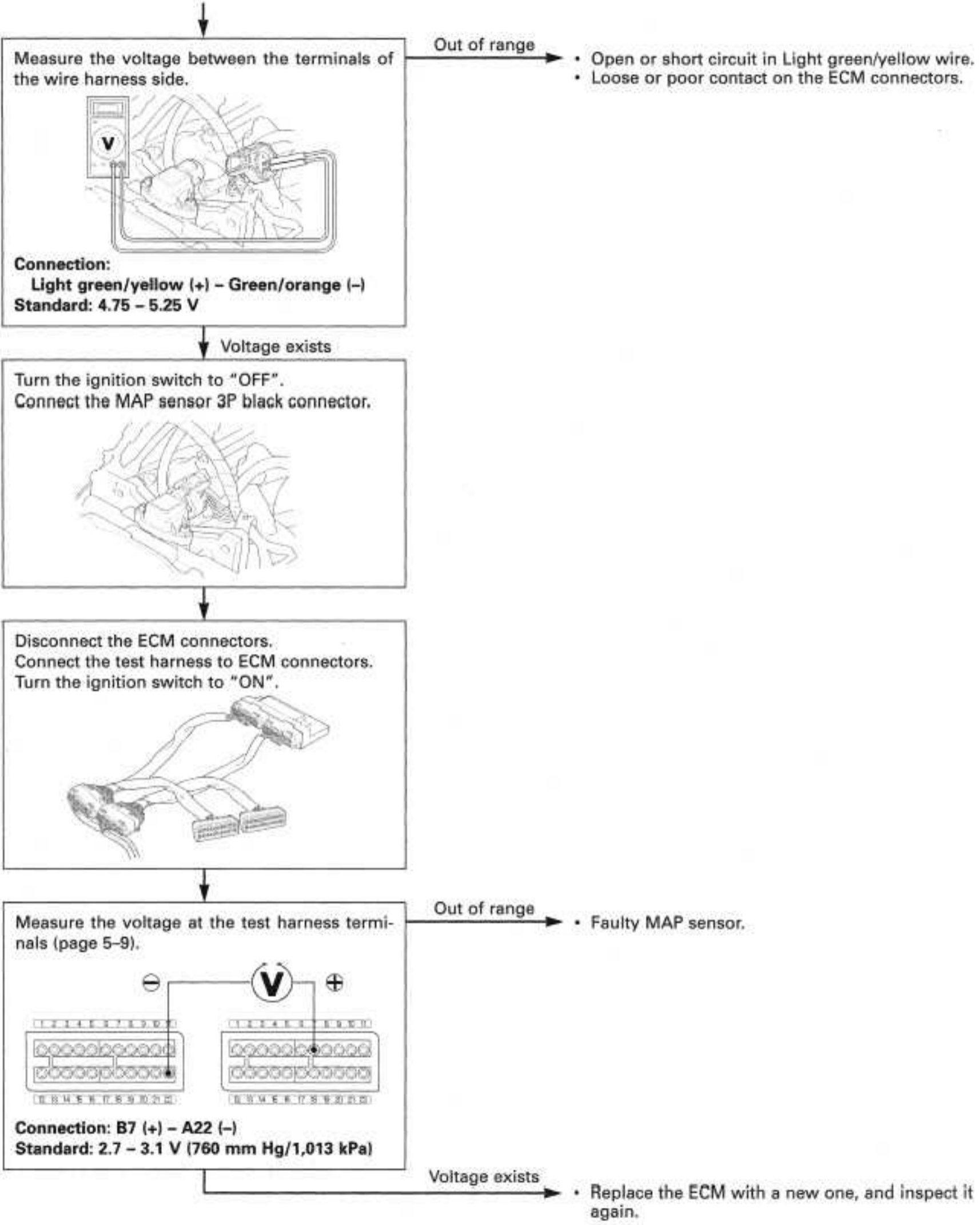



## FUEL SYSTEM (Programmed Fuel Injection)

### PGM-FI MIL 2 BLINKS (MAP SENSOR)

Turn the ignition switch to "OFF".

Check the MAP sensor installation.



Disconnect the ECM connectors.  
Connect the test harness to the ECM connector.

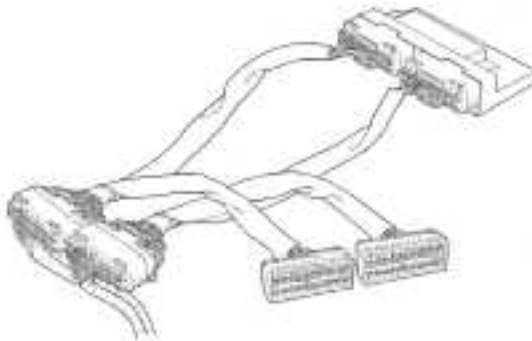

Turn the ignition switch to "ON".  
Measure the voltage at the test harness terminals (page 5-9).

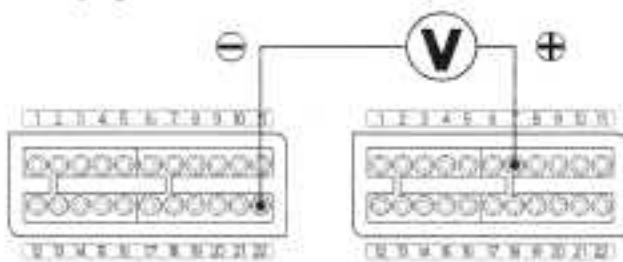

Connection: B7 (+) - A22 (-)  
Standard: 2.7 - 3.1 V (760 mm Hg/1,013 kPa)

Out of range → • Faulty MAP sensor.

Voltage exists

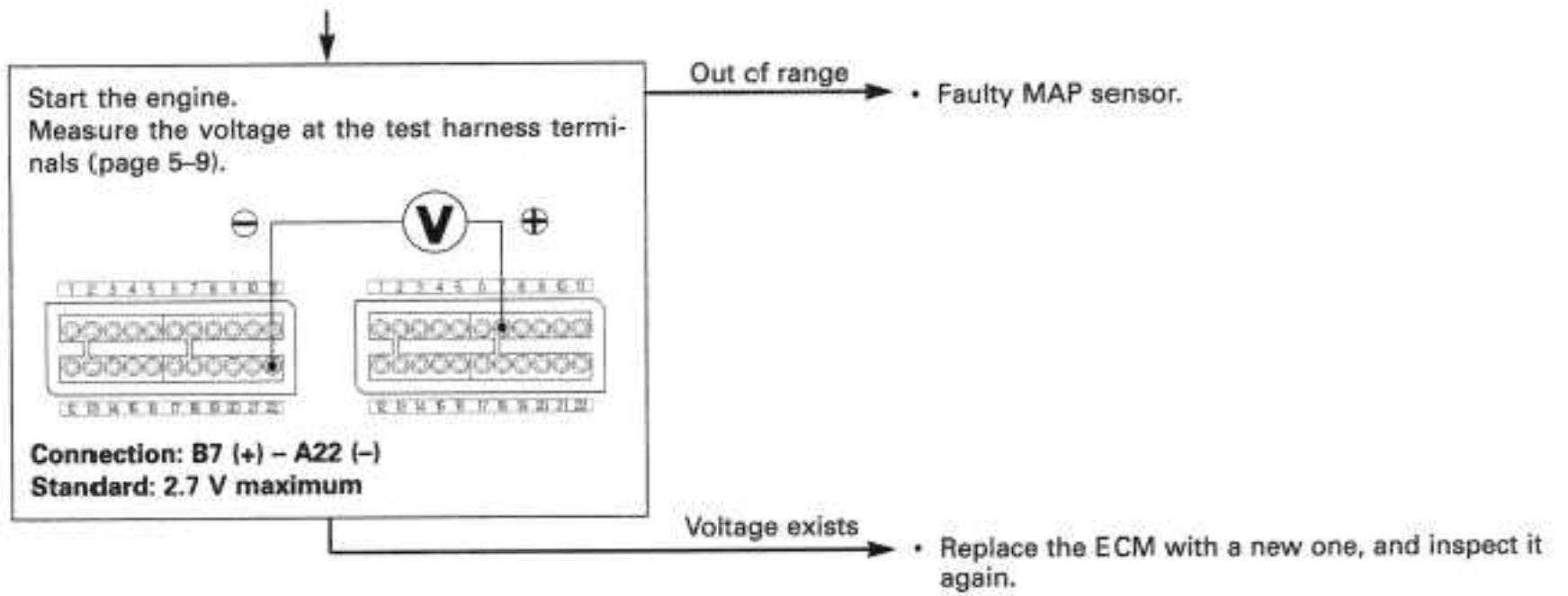

## FUEL SYSTEM (Programmed Fuel Injection)

### PGM-FI MIL 7 BLINKS (ECT SENSOR)

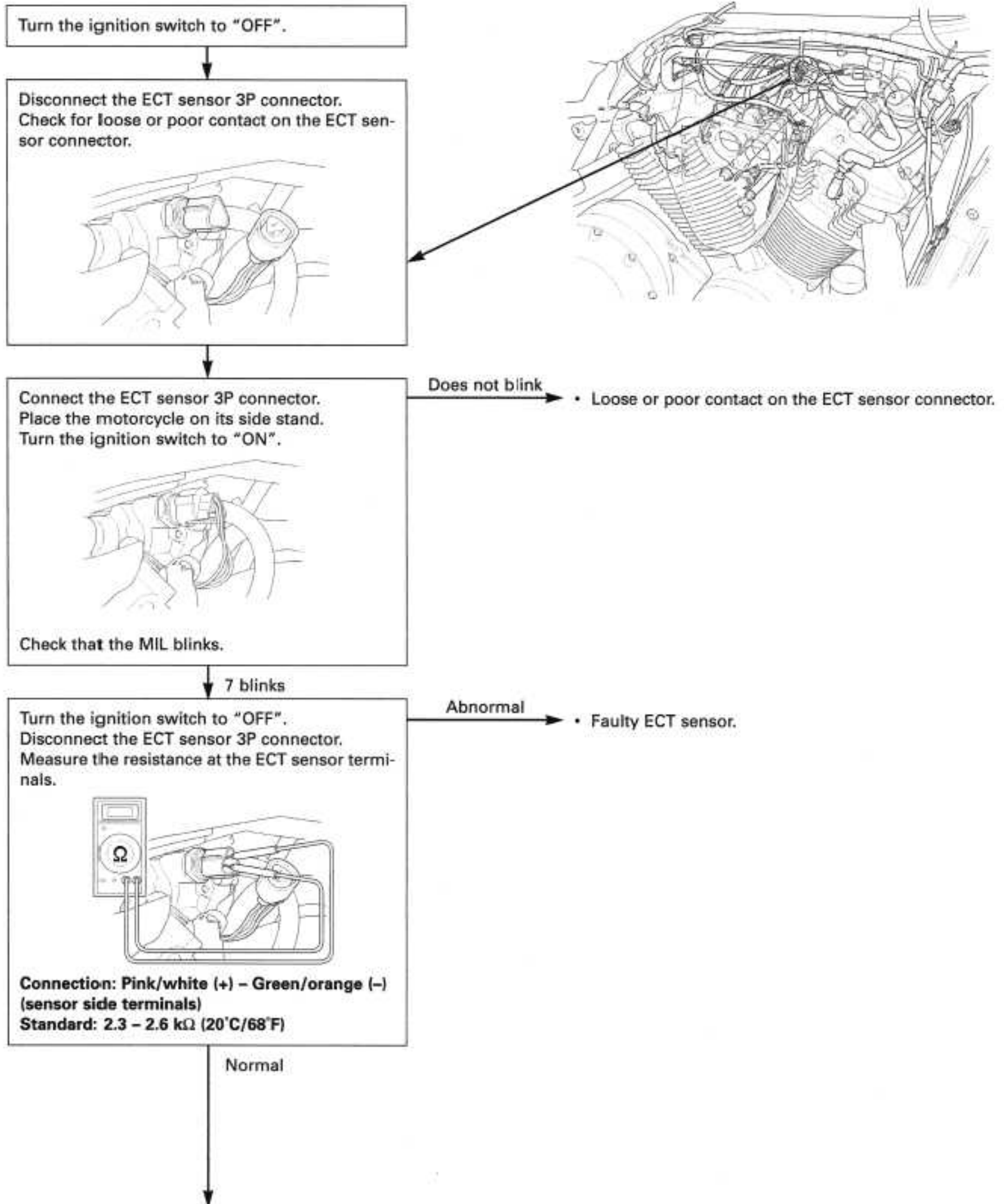

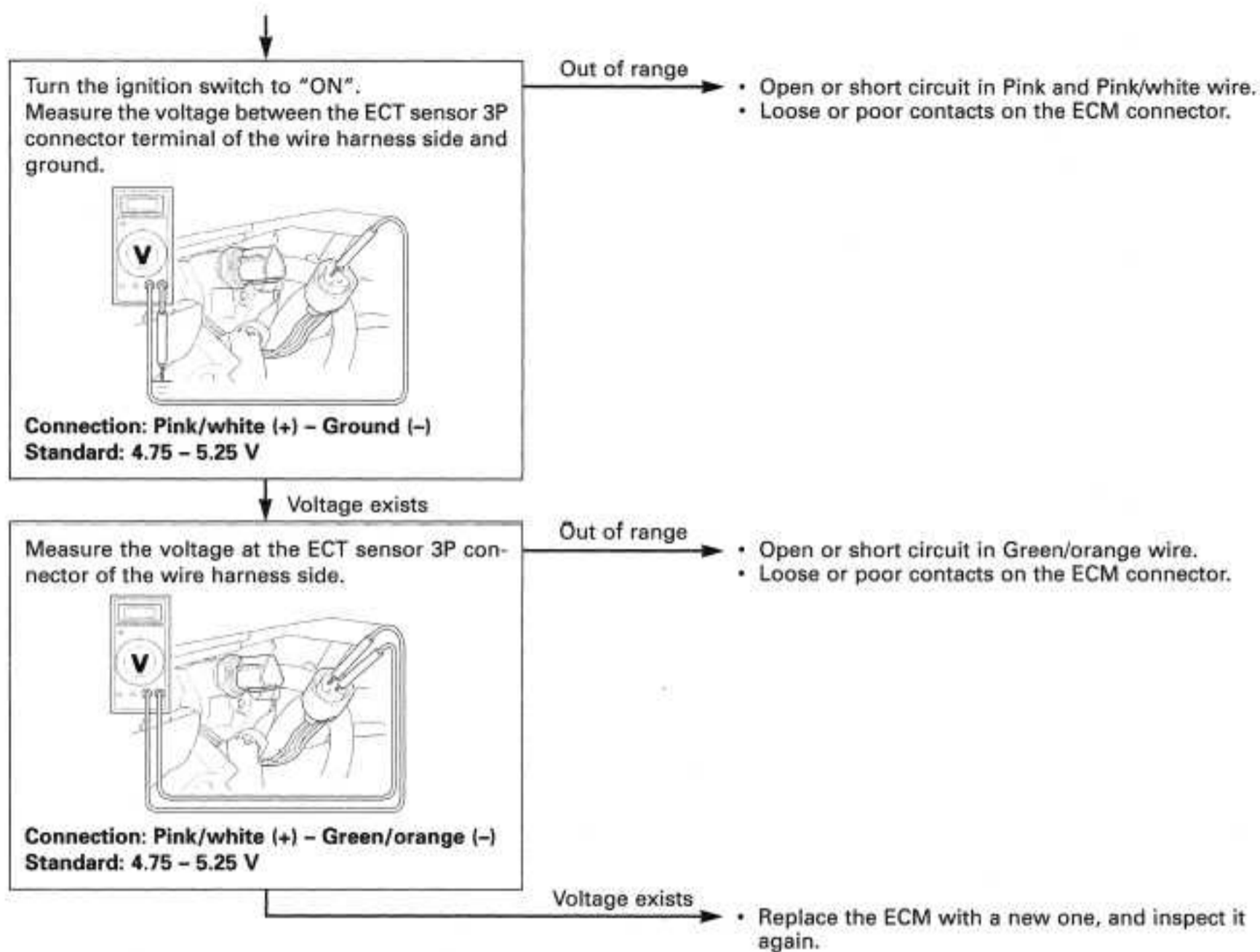



## FUEL SYSTEM (Programmed Fuel Injection)

### PGM-FI MIL 8 BLINKS (TP SENSOR)

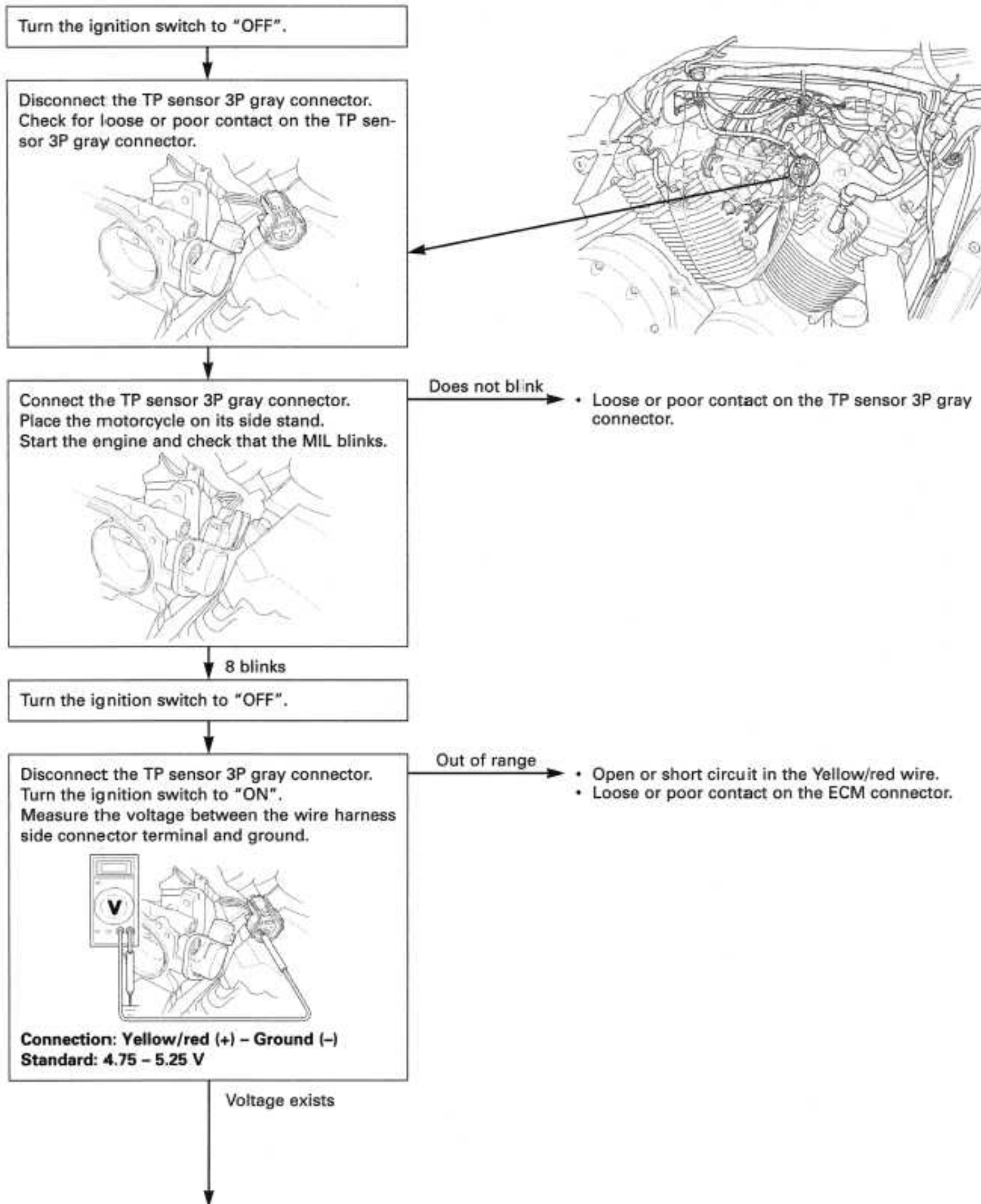

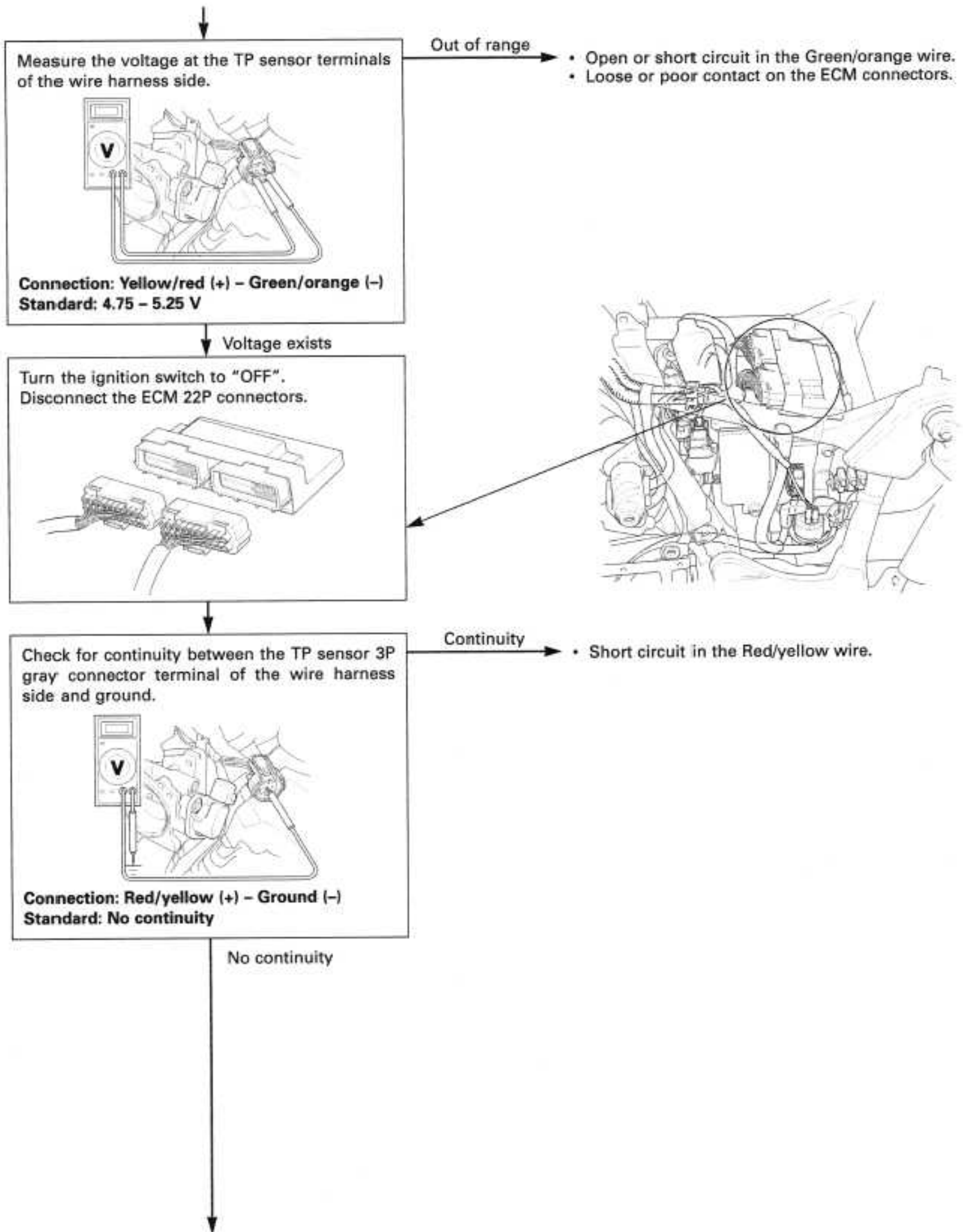

## FUEL SYSTEM (Programmed Fuel Injection)

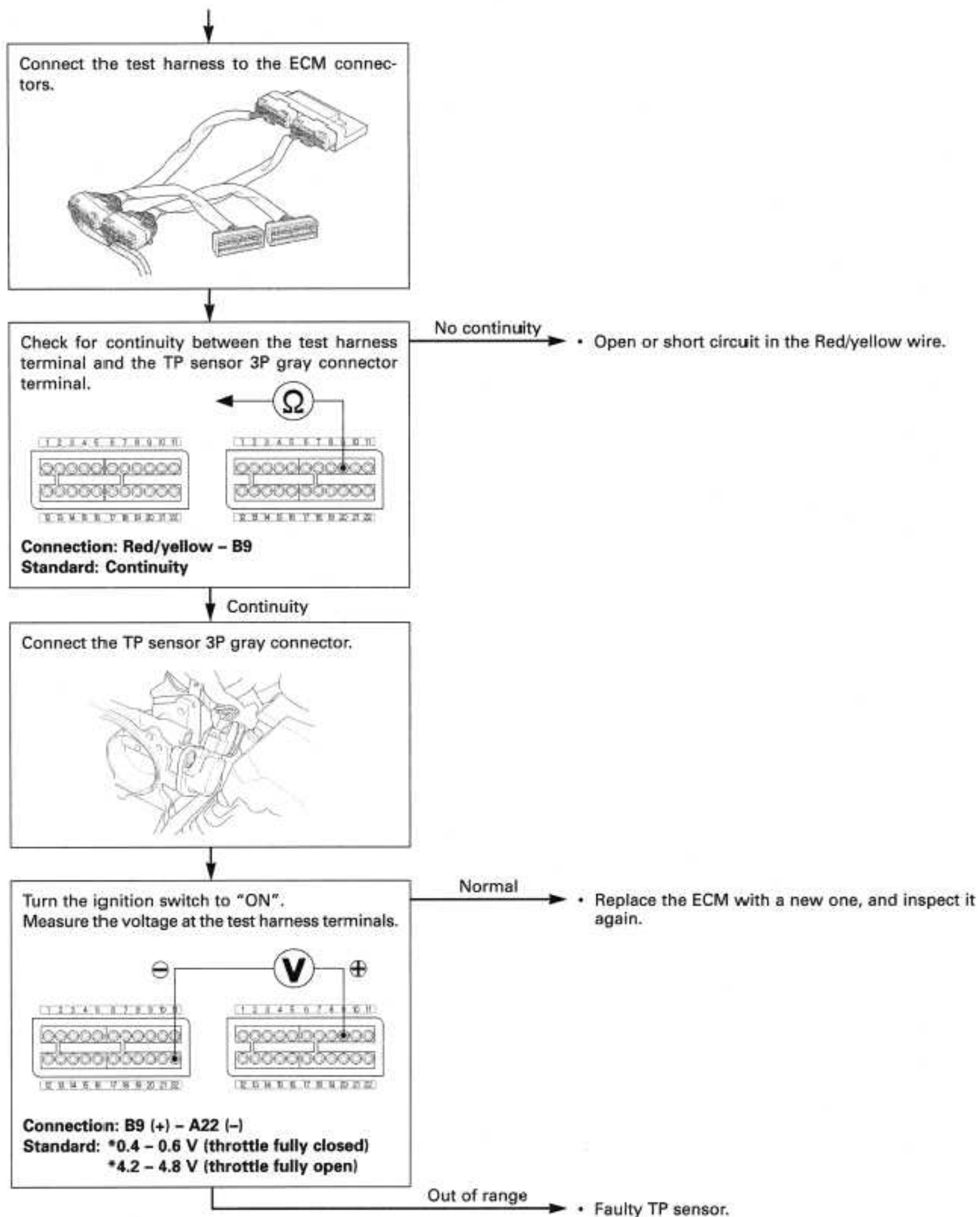

A voltage marked \* refers to the value when the voltage reading at the TP sensor 3P connector (page 5-20) shows 5 V. When the reading shows other than 5 V, derive a voltage at the test harness as follows:

In the case of a voltage of 4.75 V at the TP sensor 3P connector:

$$0.4 \times 4.75/5.0 = 0.38 \text{ V}$$

$$0.6 \times 4.75/5.0 = 0.57 \text{ V}$$

Thus, the solution is "0.38 – 0.57 V" with the throttle fully closed.

Replace 0.4 and 0.6 with 4.2 and 4.8 respectively, in the above equations to determine the throttle fully open range.

## FUEL SYSTEM (Programmed Fuel Injection)

### PGM-FI MIL 9 BLINKS (IAT SENSOR)

Turn the ignition switch to "OFF".

Disconnect the IAT sensor 2P connector.  
Check for loose or poor contact on the IAT sensor connector.

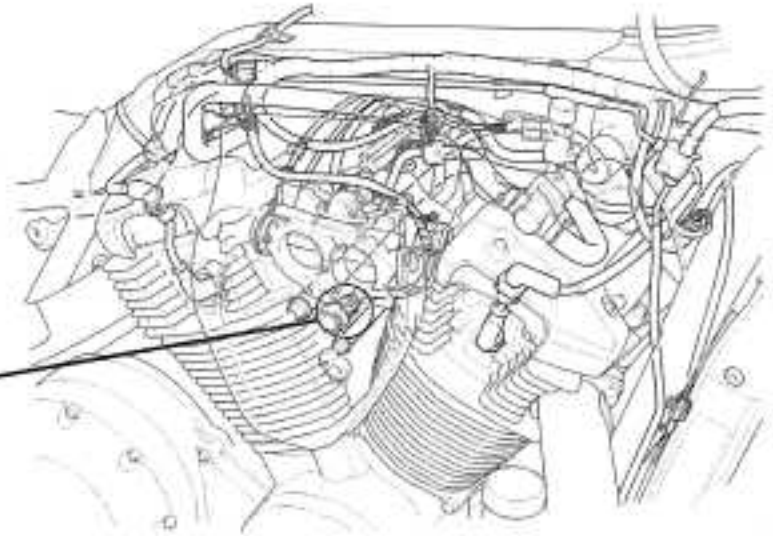

Connect the IAT sensor 2P connector.  
Place the motorcycle on its side stand.  
Turn the ignition switch to "ON".  
Check that the MIL blinks.

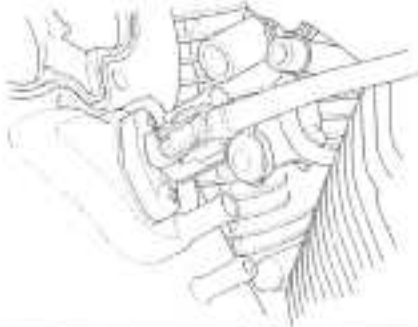

Does not blink

• Loose or poor contact on the IAT sensor connector.

9 blinks

Turn the ignition switch to "OFF".

Disconnect the IAT sensor 2P connector.  
Measure the resistance at the IAT sensor (at 20 - 30 °C/68 - 86 °F).

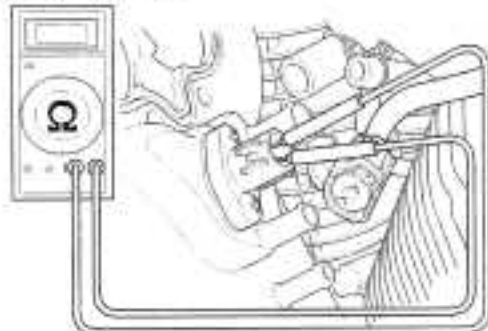

Abnormal

• Faulty IAT sensor.

Standard: 1 - 4 k $\Omega$

Normal

Turn the ignition switch to "ON".



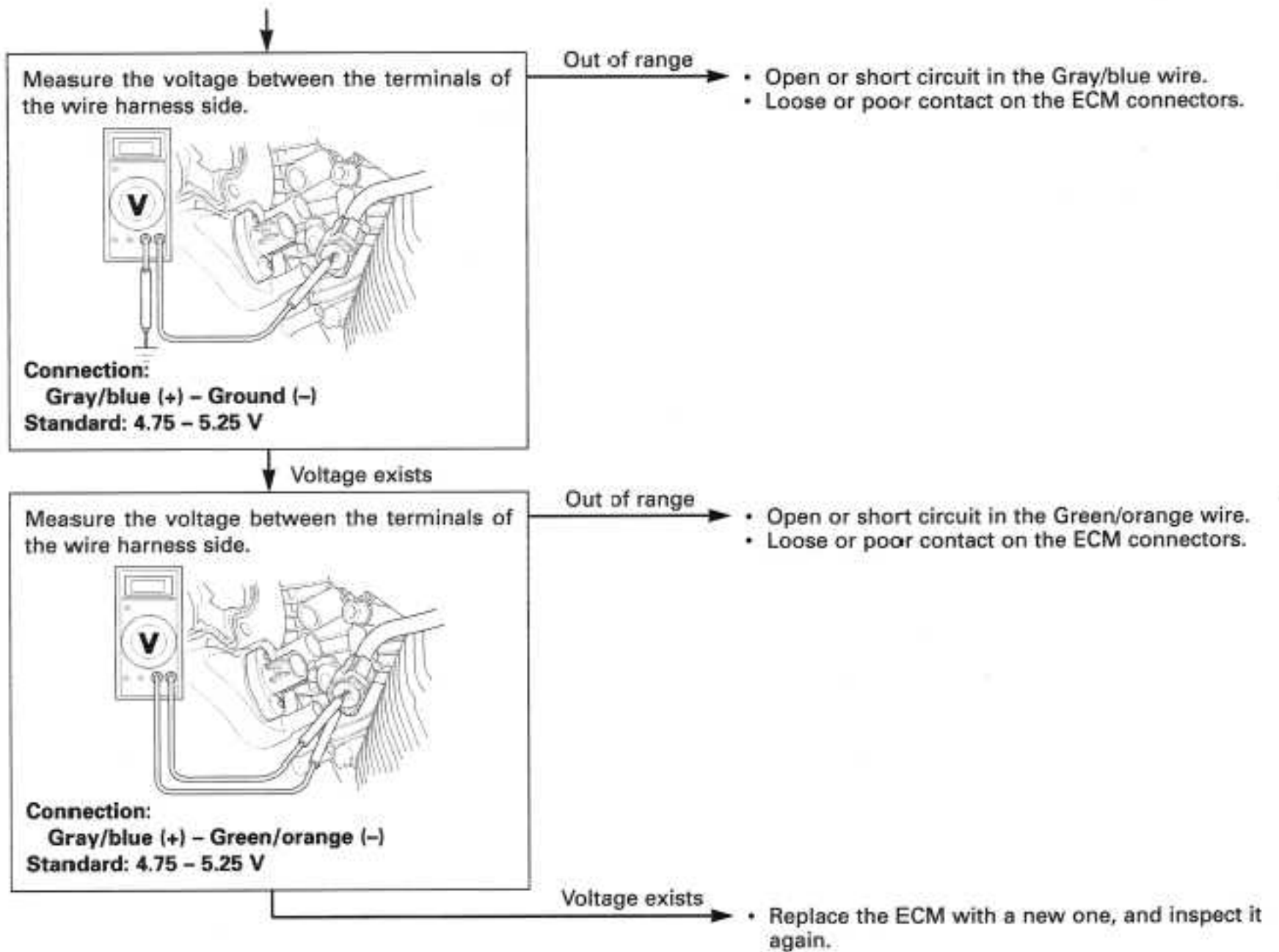

## FUEL SYSTEM (Programmed Fuel Injection)

### PGM-FI MIL 10 BLINK (BARO SENSOR)

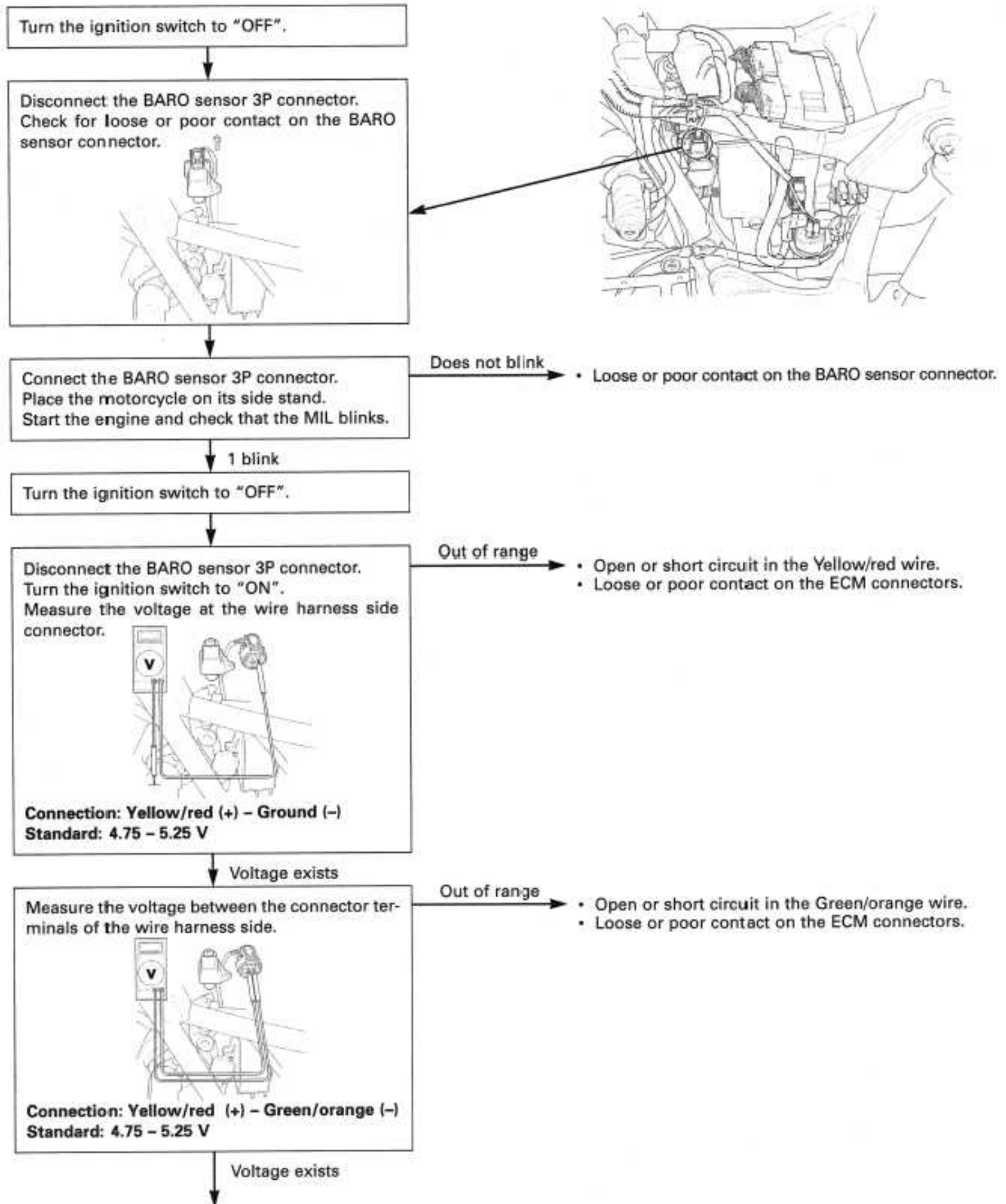

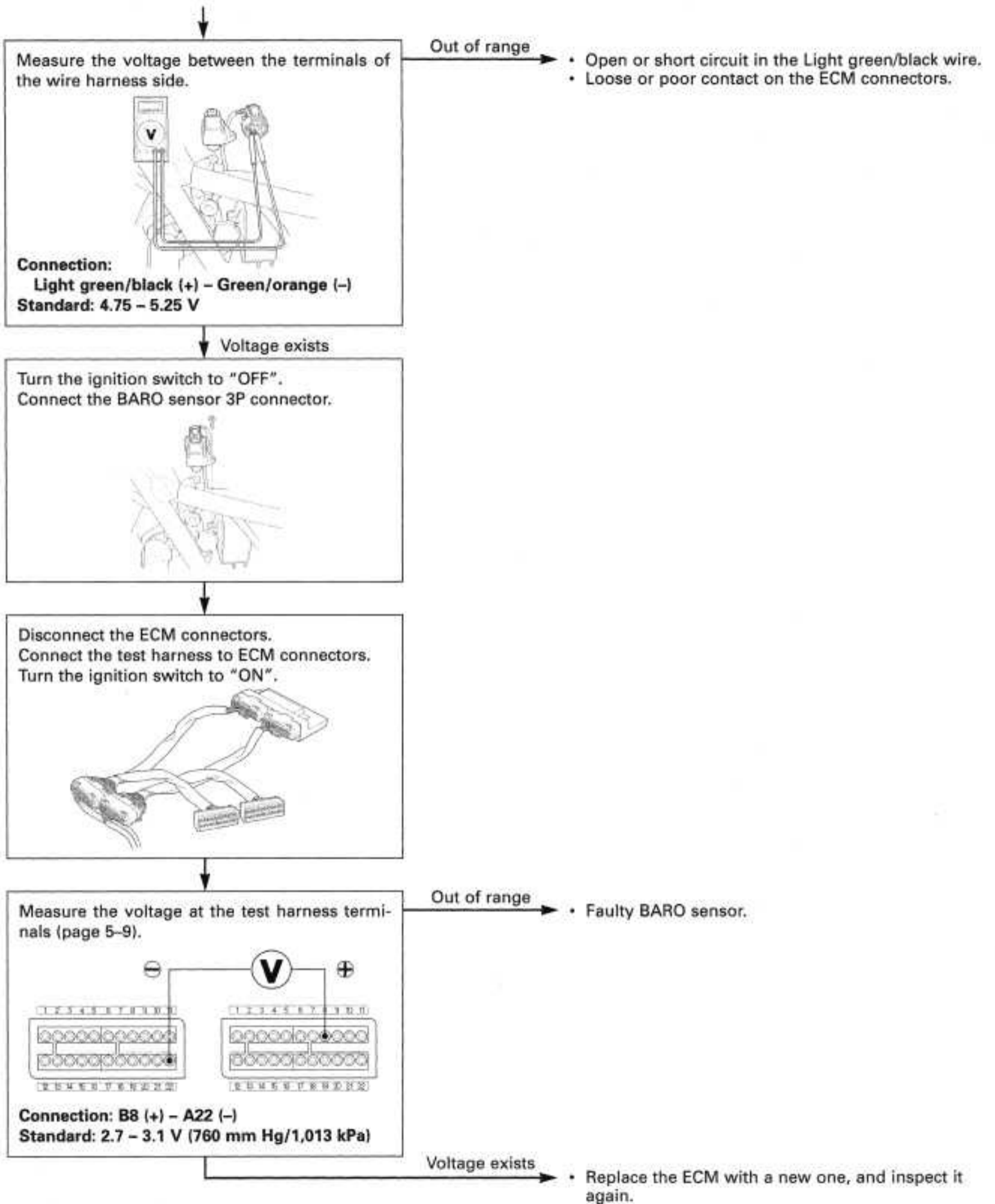

## FUEL SYSTEM (Programmed Fuel Injection)

### PGM-FI MIL 11 BLINKS (VEHICLE SPEED SENSOR)

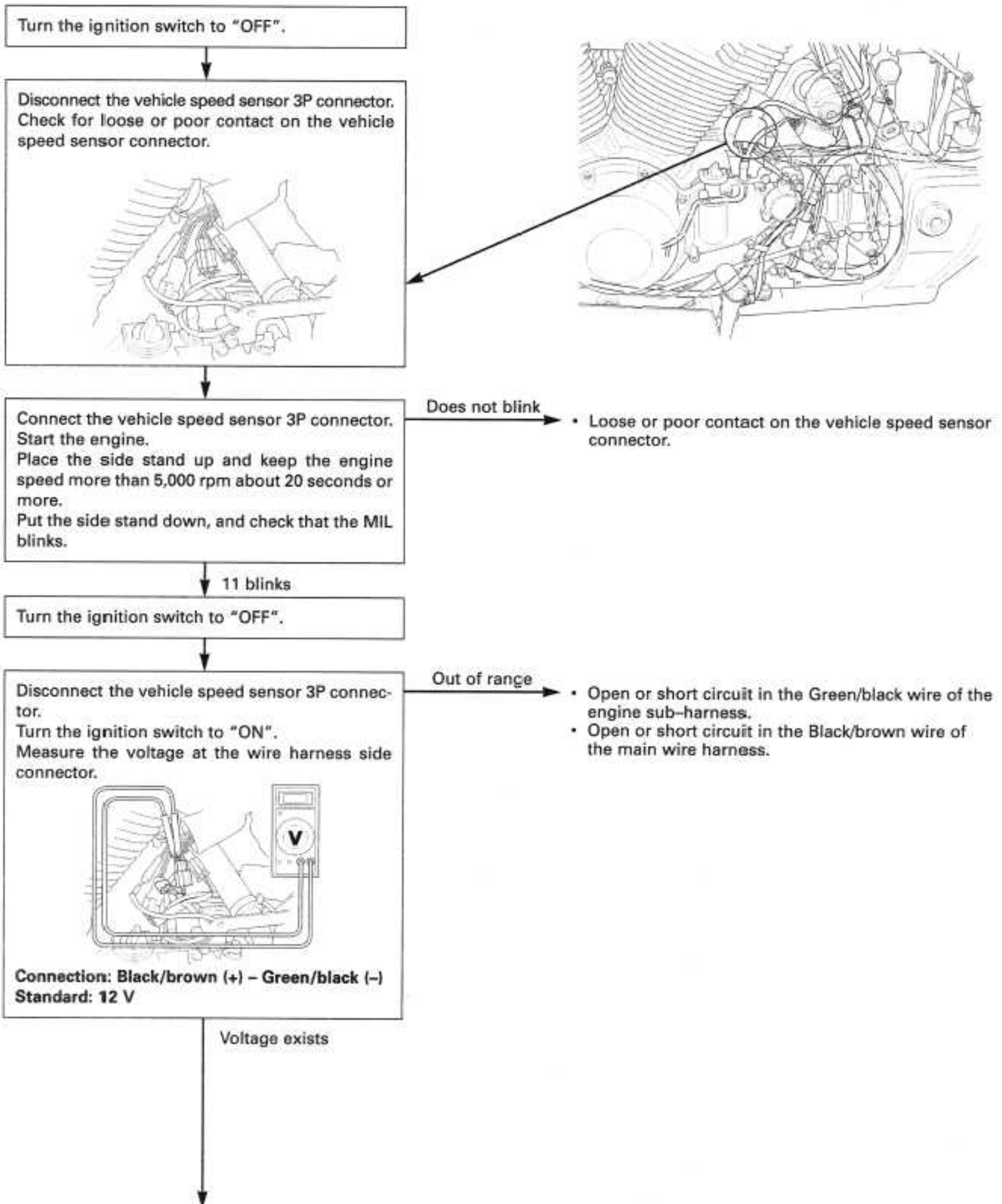

Connect the speed sensor 3P connector.



Disconnect the ECM connectors.  
Connect the test harness to the wire harness connectors.

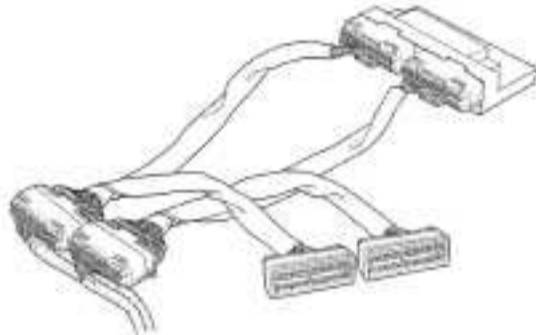

Support the motorcycle securely and place the rear wheel off the ground.  
Shift the transmission into gear.  
Measure the voltage at the test harness terminals with the ignition switch turned to "ON" while slowly turning the rear wheel by hand.

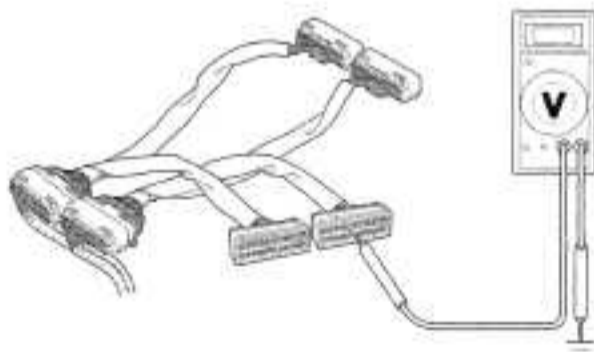

**CONNECTION:** Pink/green (+) - Ground (-)  
**STANDARD:** Repeat 0 to 5V

Abnormal

- Open or short circuit in the Pink wire of the engine sub-harness.
- Open or short circuit in the Pink/green wire of the main wire harness.

Normal

- Replace the ECM with a new one, and inspect it again.



## FUEL SYSTEM (Programmed Fuel Injection)

### PGM-FI MIL 12 BLINKS (REAR INJECTOR)

Turn the ignition switch to "OFF".

Disconnect the rear injector 2P gray connector. Check for loose or poor contact on the rear injector 2P gray connector.

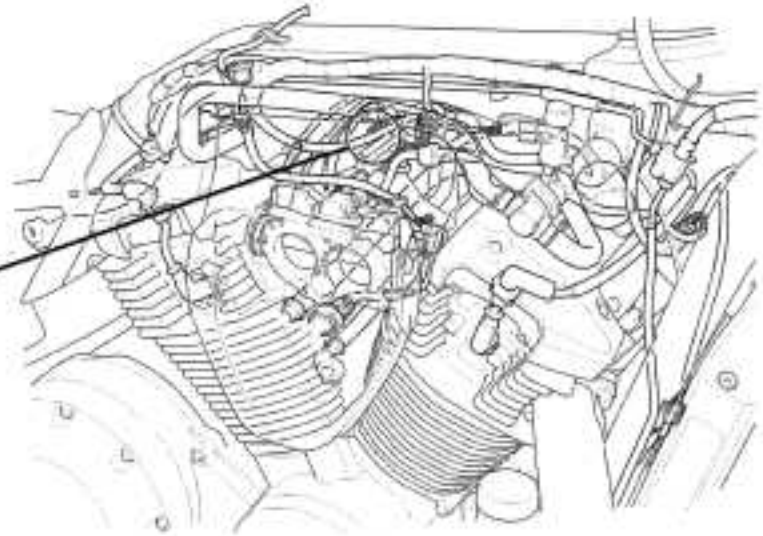

Connect the rear injector 2P gray connector. Place the motorcycle on its side stand. Turn the ignition switch to "ON". Check that the MIL blinks.

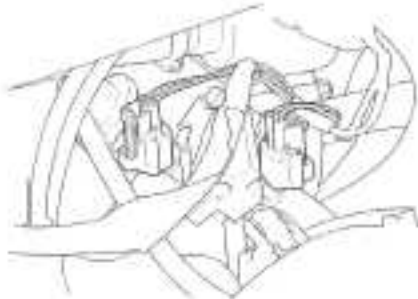

Does not blink

- Loose or poor contact on the rear injector 2P gray connector.

13 blinks

Abnormal

- Faulty rear injector.

Turn the ignition switch to "OFF". Disconnect the rear injector 2P gray connector and measure the resistance of the rear injector.

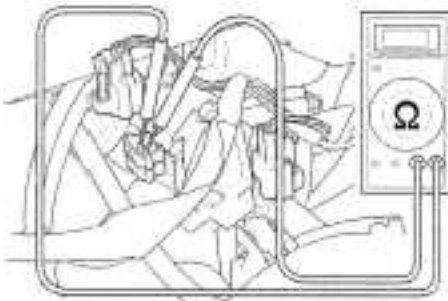

**Connection:**

**Black/white (+) - Pink/yellow (-)**  
**Standard: 13.4 - 14.2  $\Omega$  (20°C/68°F)**

Normal

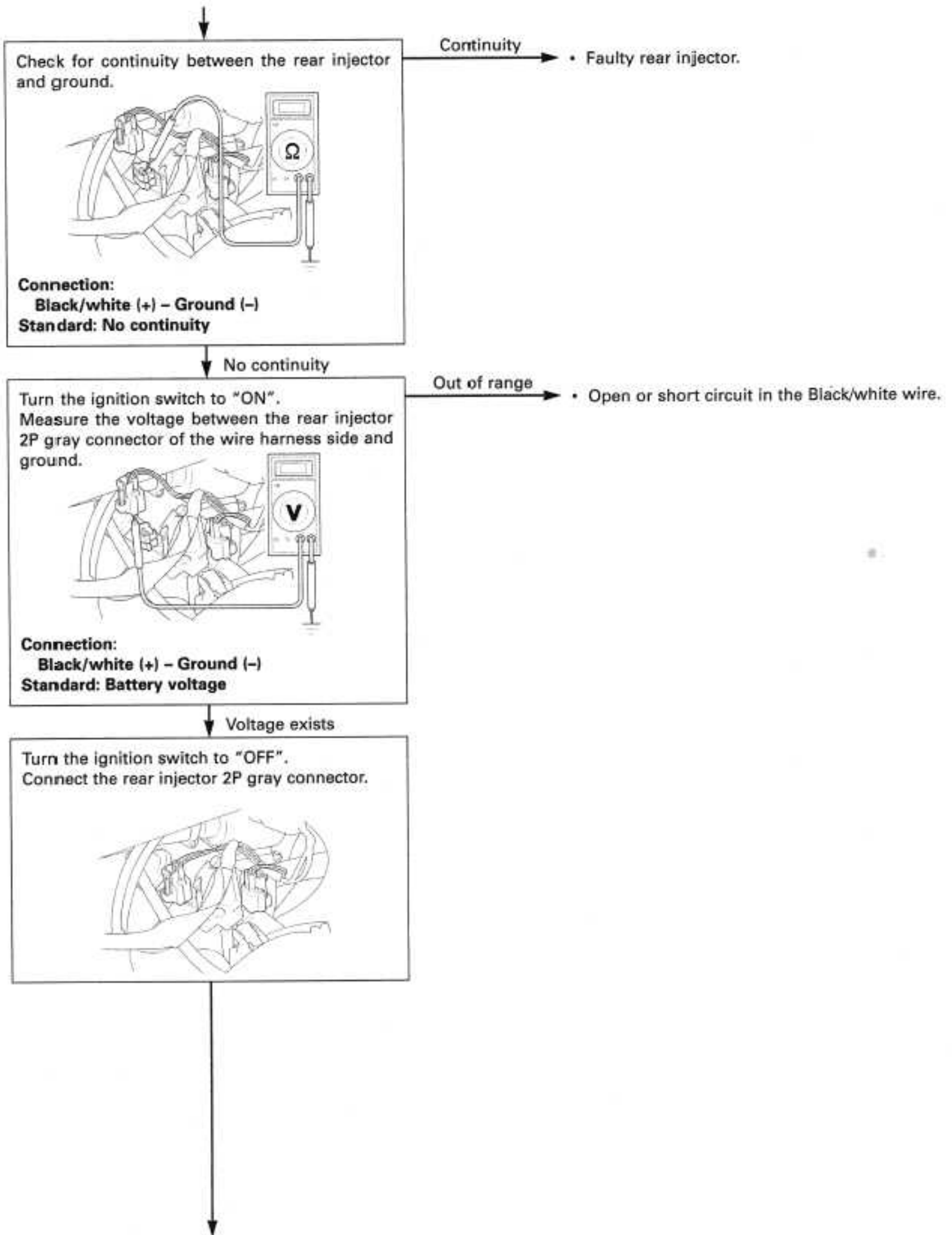

## FUEL SYSTEM (Programmed Fuel Injection)

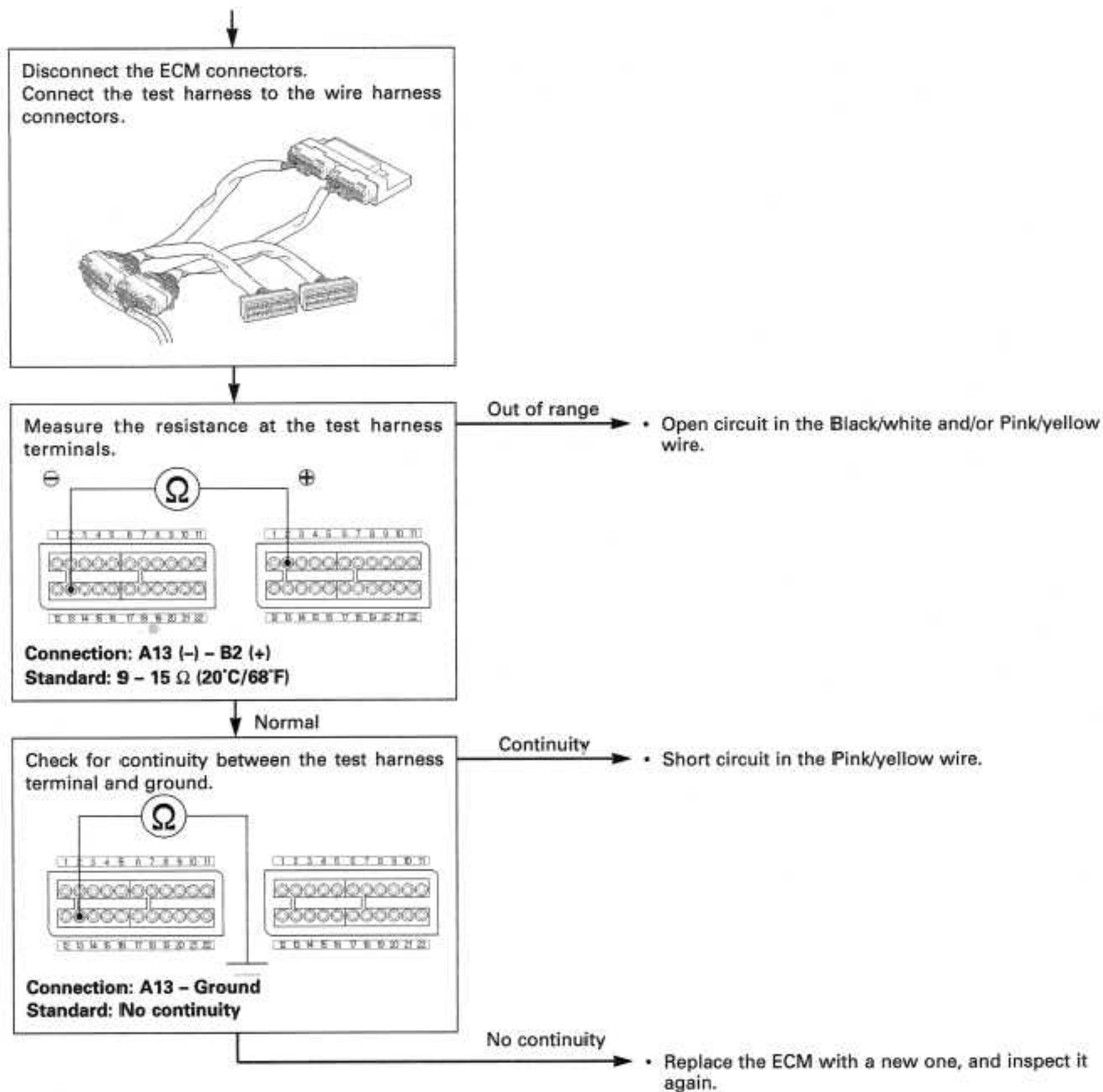

PGM-FI MIL 13 BLINKS (FRONT INJECTOR)

Turn the ignition switch to "OFF".

Disconnect the front injector 2P brown connector. Check for loose or poor contact on the front injector 2P brown connector.

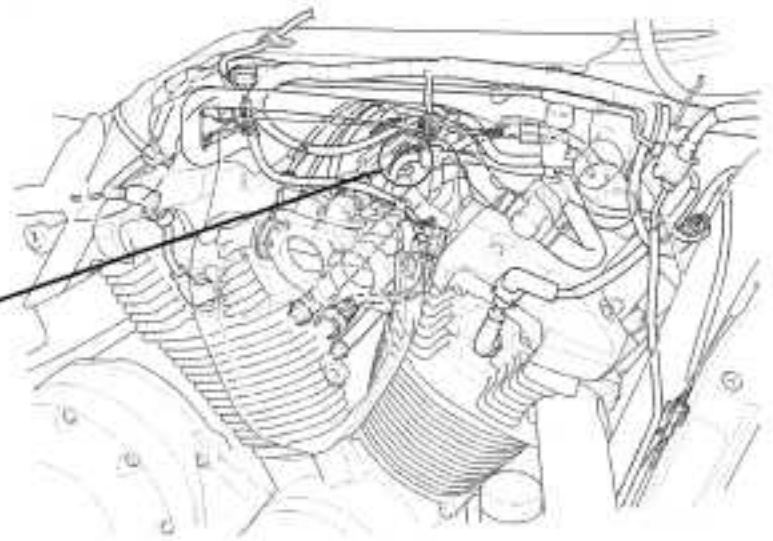
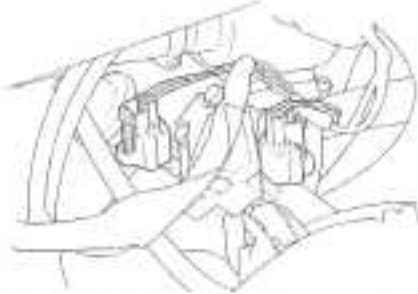

Connect the front injector 2P brown connector. Place the motorcycle on its side stand. Turn the ignition switch to "ON". Check that the MIL blinks.



Does not blink

- Loose or poor contact on the front injector 2P brown connector.

12 blinks

Abnormal

- Faulty front injector.

Turn the ignition switch to "OFF". Disconnect the front injector 2P brown connector and measure the resistance of the front injector

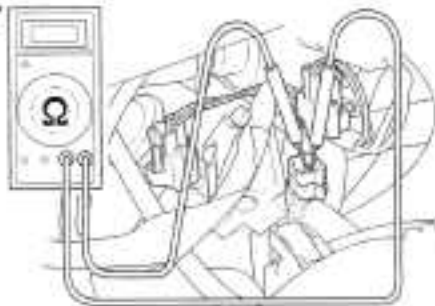

Connection:  
 Black/white (+) - Pink/blue (-)  
 Standard: 13.2 - 14.2  $\Omega$  (20°C/68°F)

Normal

## FUEL SYSTEM (Programmed Fuel Injection)

---

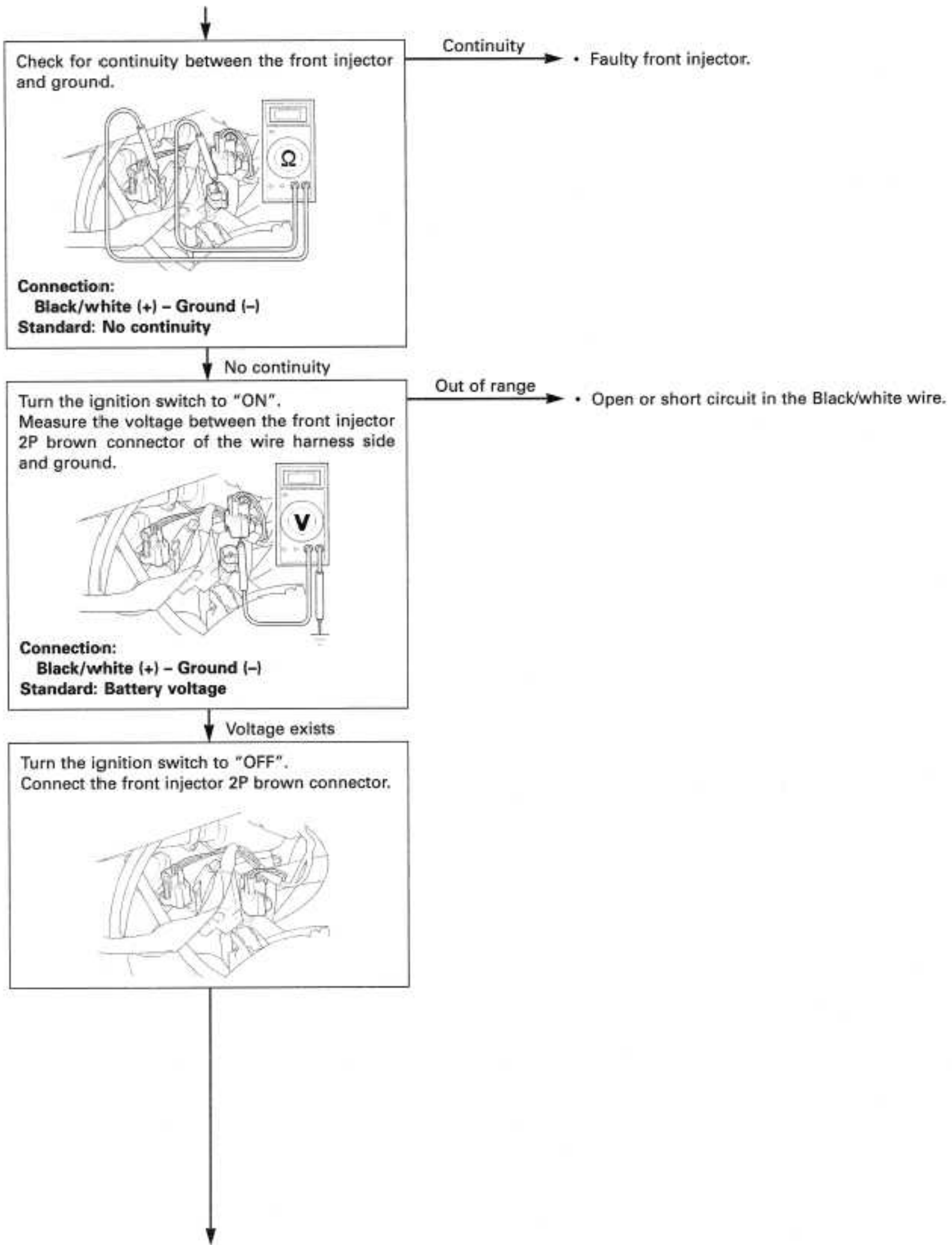



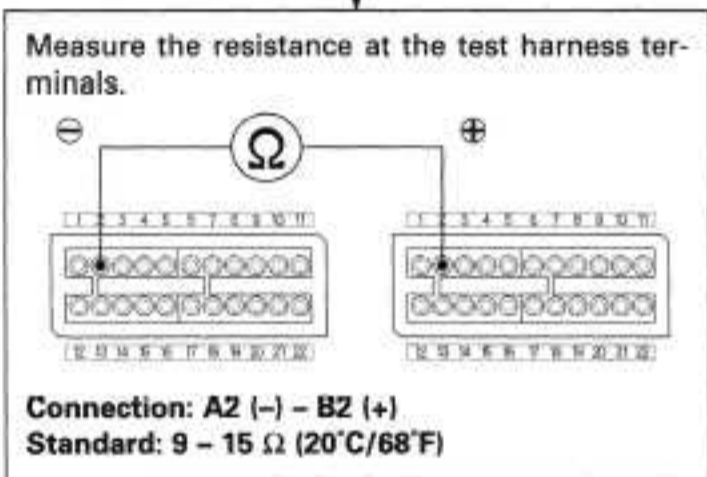
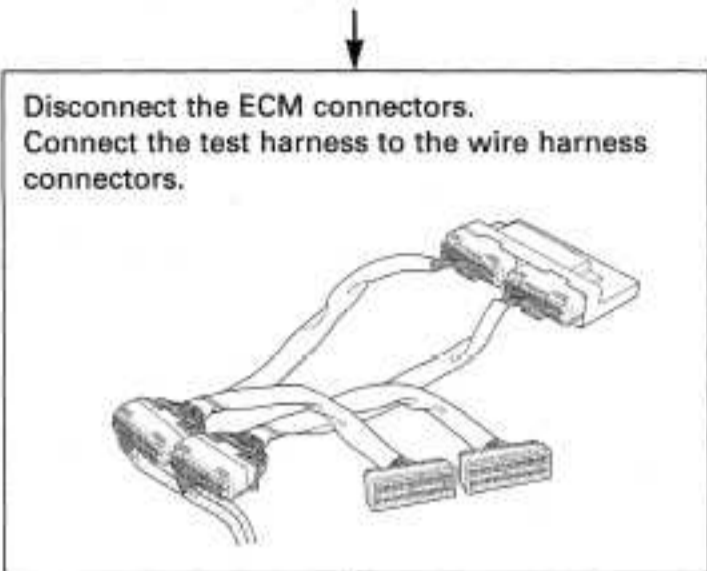

Out of range → • Open circuit in the Black/white and/or Pink/blue wire.

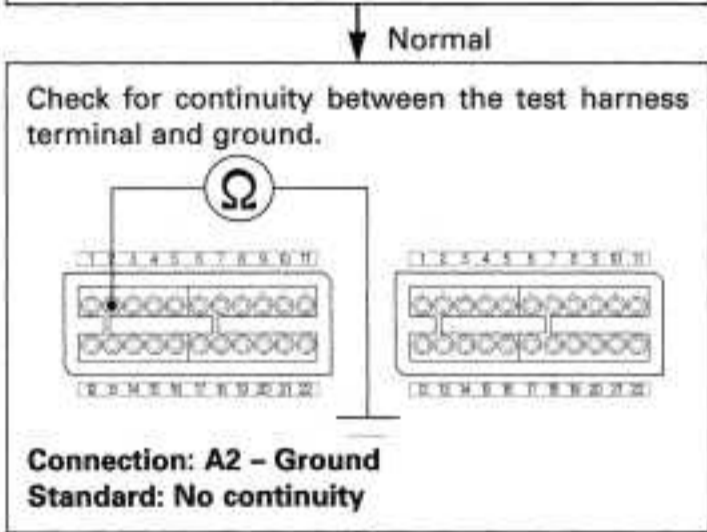

Continuity → • Short circuit in the Pink/blue wire.

No continuity → • Replace the ECM with a new one, and inspect it again.

## FUEL SYSTEM (Programmed Fuel Injection)

### PGM-FI MIL 18 BLINKS (CAM PULSE GENERATOR)

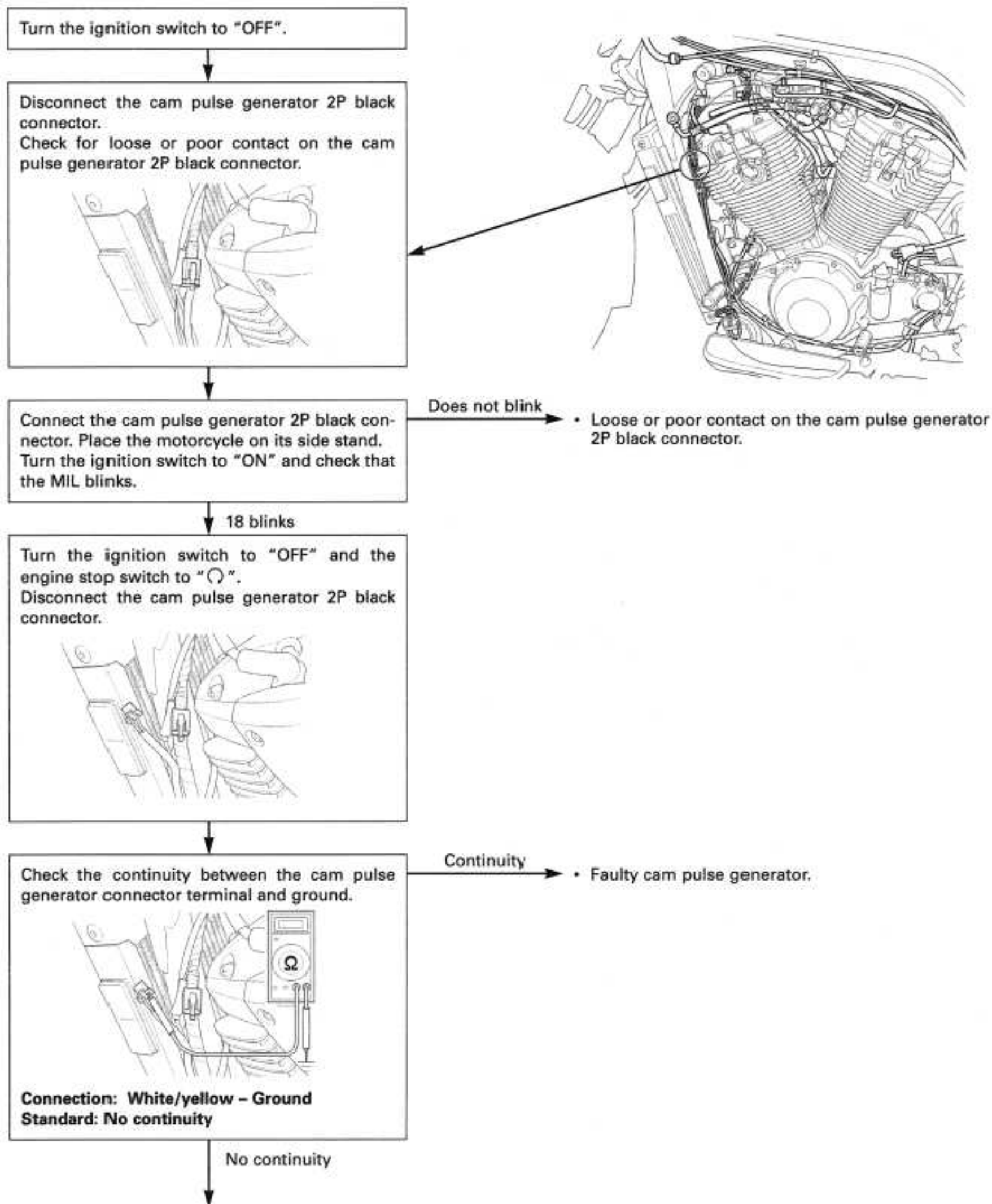

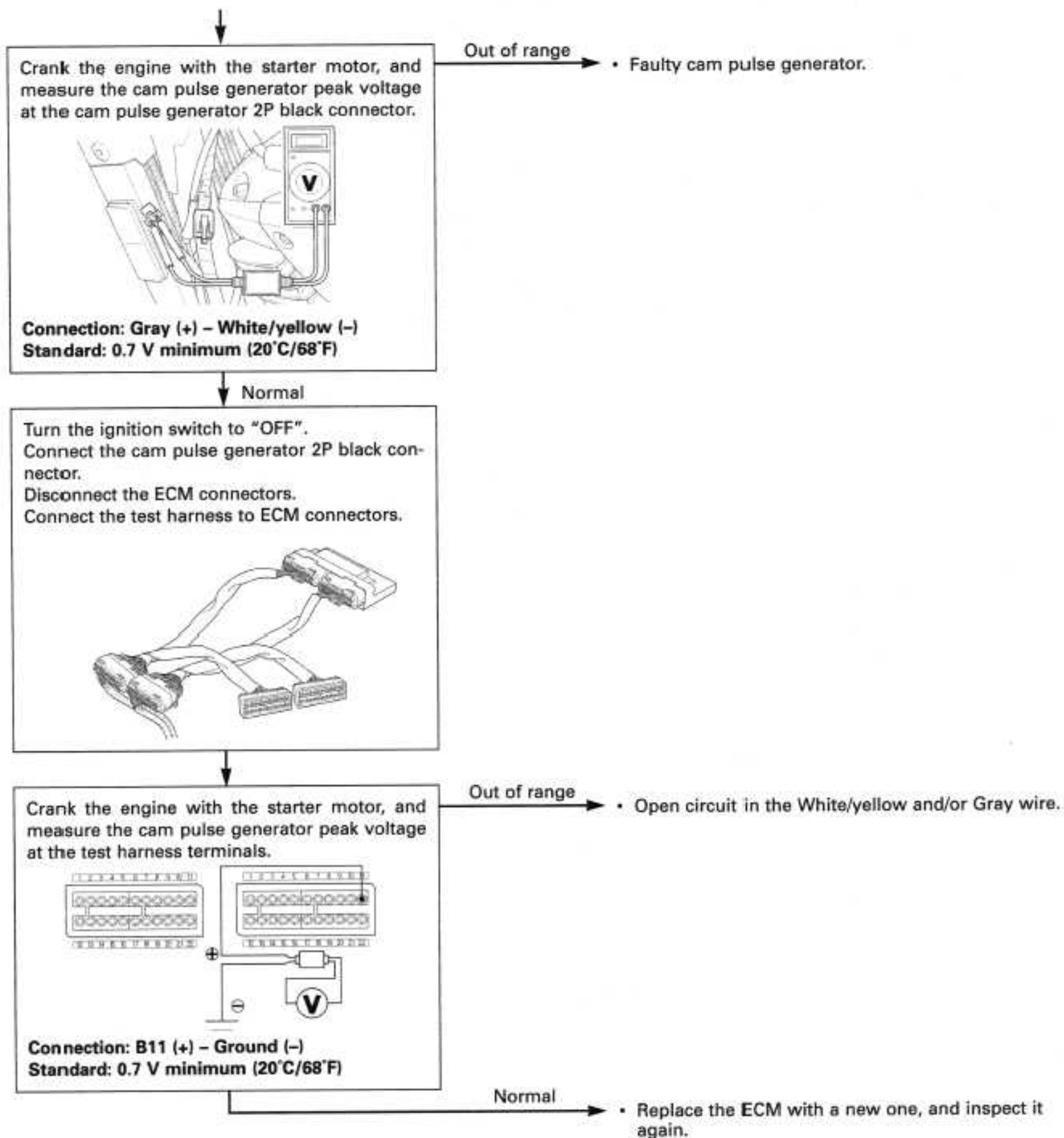

## FUEL SYSTEM (Programmed Fuel Injection)

### PGM-FI MIL 19 BLINKS (IGNITION PULSE GENERATOR)

Turn the ignition switch to "OFF".

Disconnect the ignition pulse generator 2P connector.  
Check for loose or poor contact on the ignition pulse generator 2P connector.

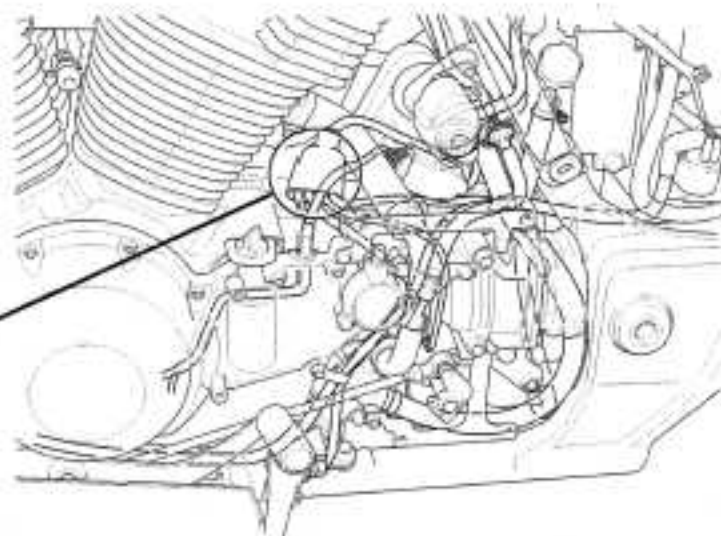

Connect the ignition pulse generator 2P connector.  
Place the motorcycle on its side stand.  
Turn the ignition switch to "ON" and check that the MIL blinks.

Does not blink

- Loose or poor contact on the ignition pulse generator 2P connector.

19 blinks

Turn the ignition switch to "OFF" and the engine stop switch to "O".  
Disconnect the ignition pulse generator 2P connector.



Check the continuity between the ignition pulse generator connector terminal and ground.

Abnormal

- Faulty ignition pulse generator.



Connection: White/yellow - Ground  
Standard: No continuity

No continuity

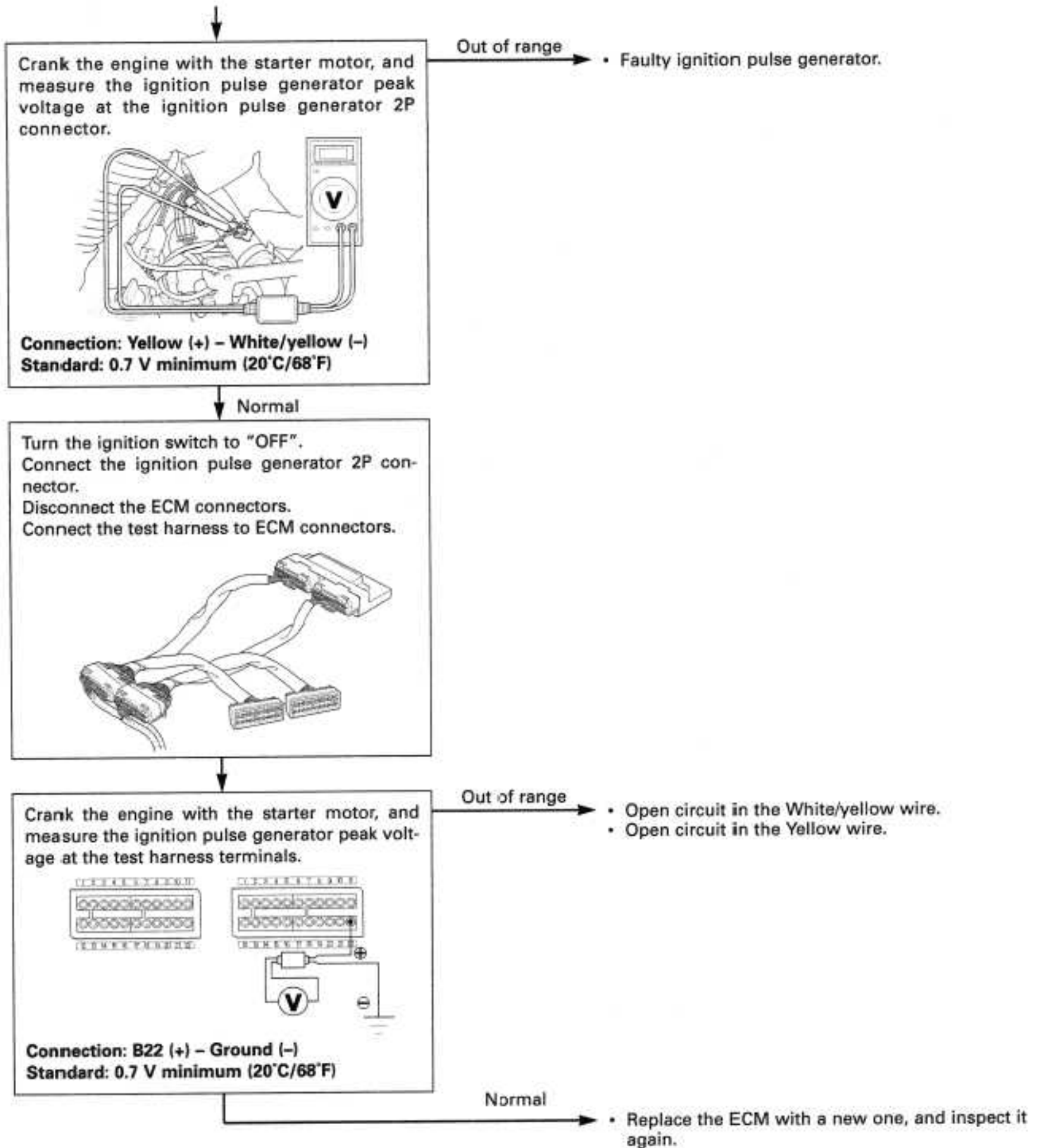



## FUEL SYSTEM (Programmed Fuel Injection)

### PGM-FI MIL 21 BLINKS (REAR O<sub>2</sub> SENSOR/CALIFORNIA TYPE ONLY)

Turn the ignition switch to "OFF".

Disconnect the rear O<sub>2</sub> sensor 4P black connector. Check for loose or poor contact on the rear O<sub>2</sub> sensor 4P black connector.

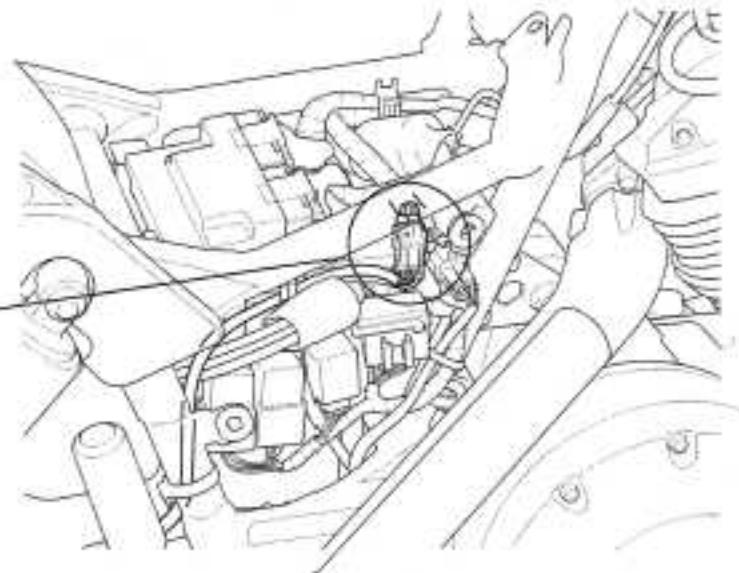

Disconnect the ECM connectors. Connect the test harness to ECM connectors.

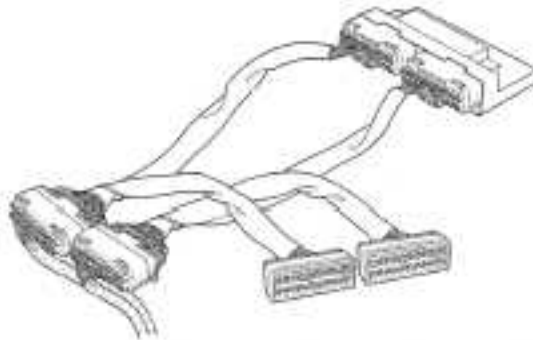

Check the continuity between the test harness terminal and rear O<sub>2</sub> sensor 4P black connector terminal.

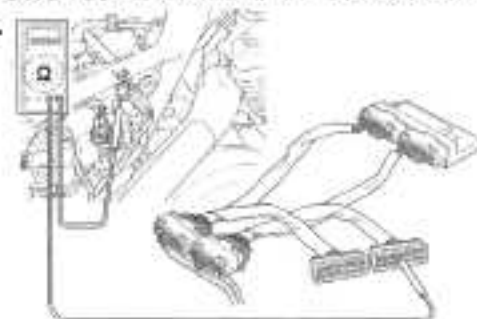

Connection: White/orange - B5  
Standard: Continuity

No continuity

• Open circuit in rear O<sub>2</sub> sensor White/orange wire.

Continuity

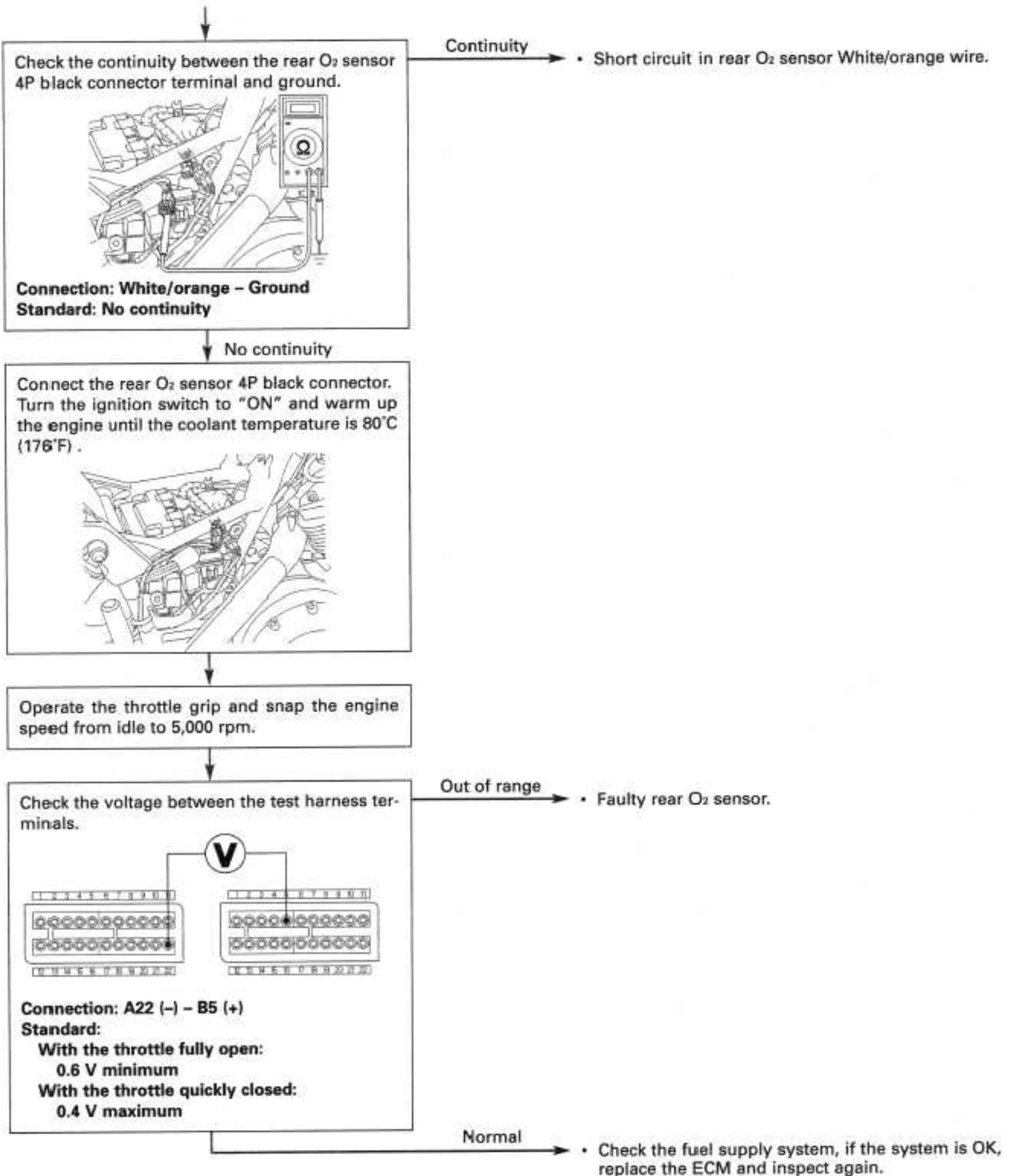

## FUEL SYSTEM (Programmed Fuel Injection)

### PGM-FI MIL 22 BLINKS (FRONT O<sub>2</sub> SENSOR/CALIFORNIA TYPE ONLY)

Turn the ignition switch to "OFF".

Disconnect the front O<sub>2</sub> sensor 4P connector.  
Check for loose or poor contact on the front O<sub>2</sub> sensor 4P connector.

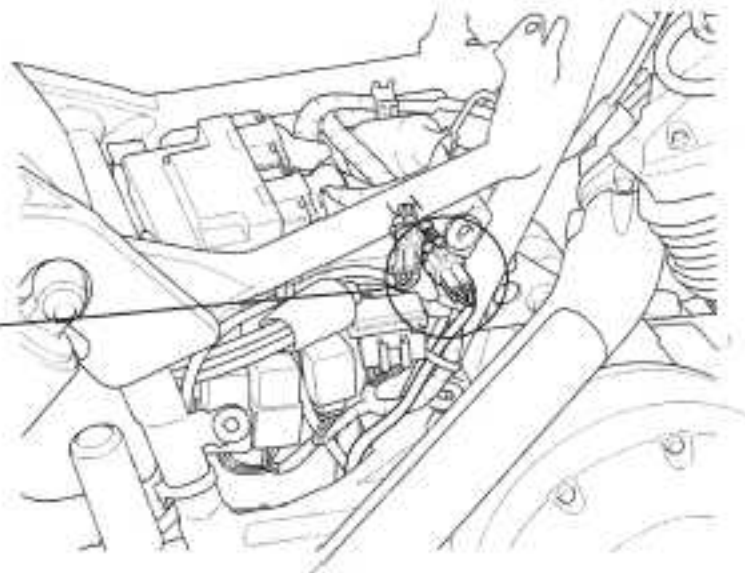
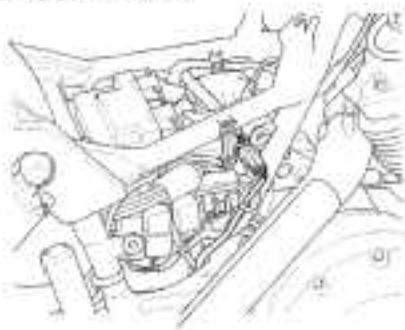

Disconnect the ECM connectors.  
Connect the test harness to ECM connectors.

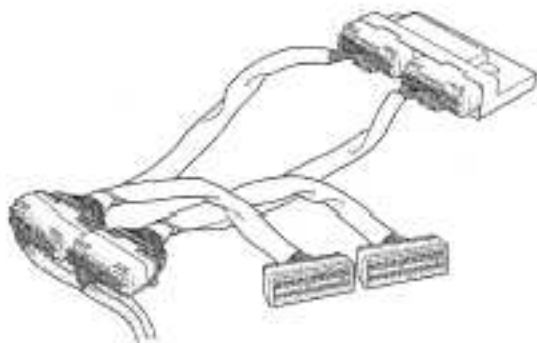

Check the continuity between the test harness terminal and front O<sub>2</sub> sensor 4P connector terminal.

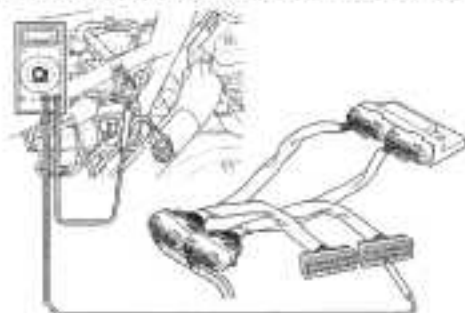

Connection: White/black - B16  
Standard: Continuity

No continuity

- Open circuit in O<sub>2</sub> sensor White/orange wire.

Continuity

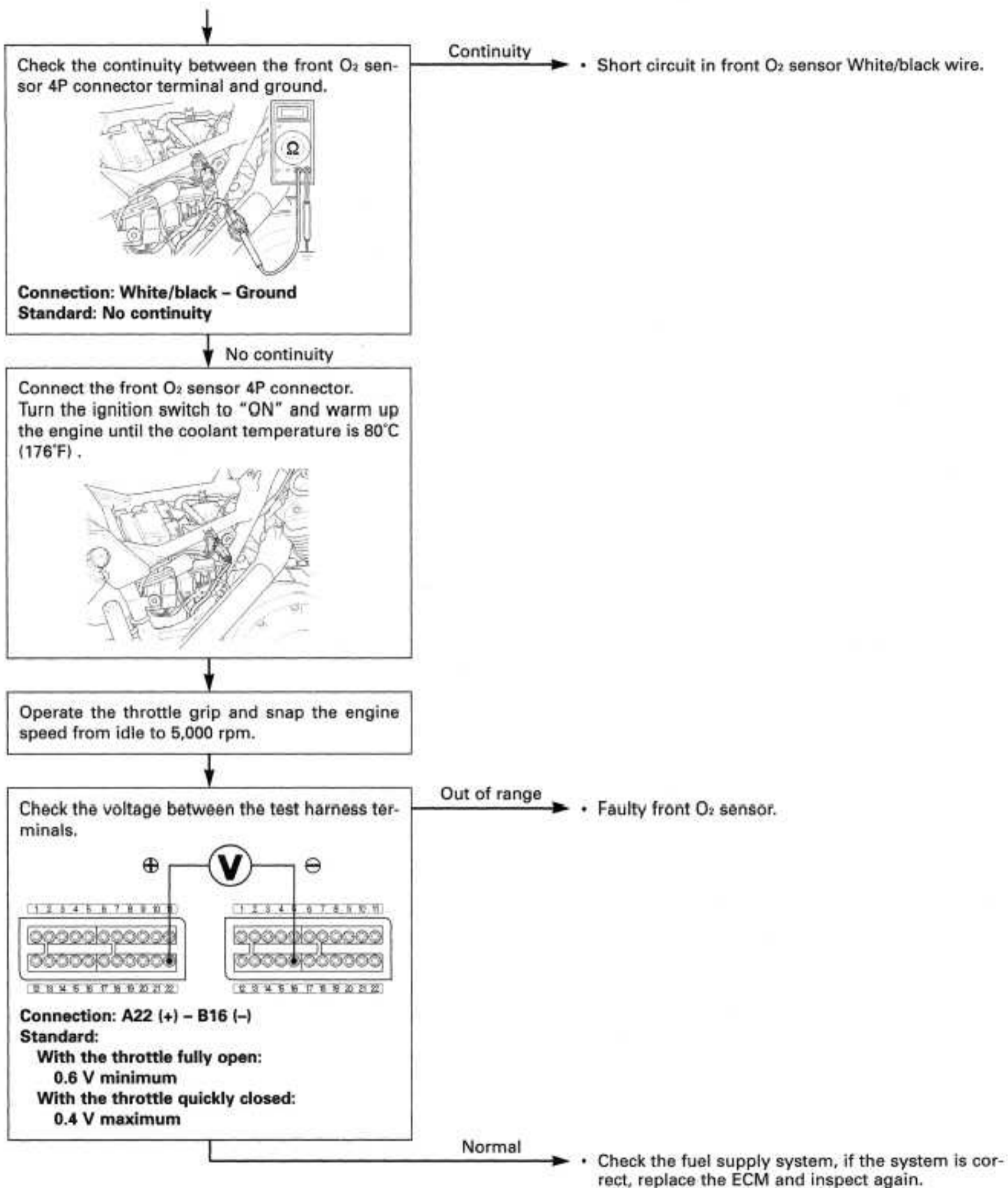

## FUEL SYSTEM (Programmed Fuel Injection)

### PGM-FI MIL 23 BLINKS (REAR O<sub>2</sub> SENSOR HEATER/CALIFORNIA TYPE ONLY)

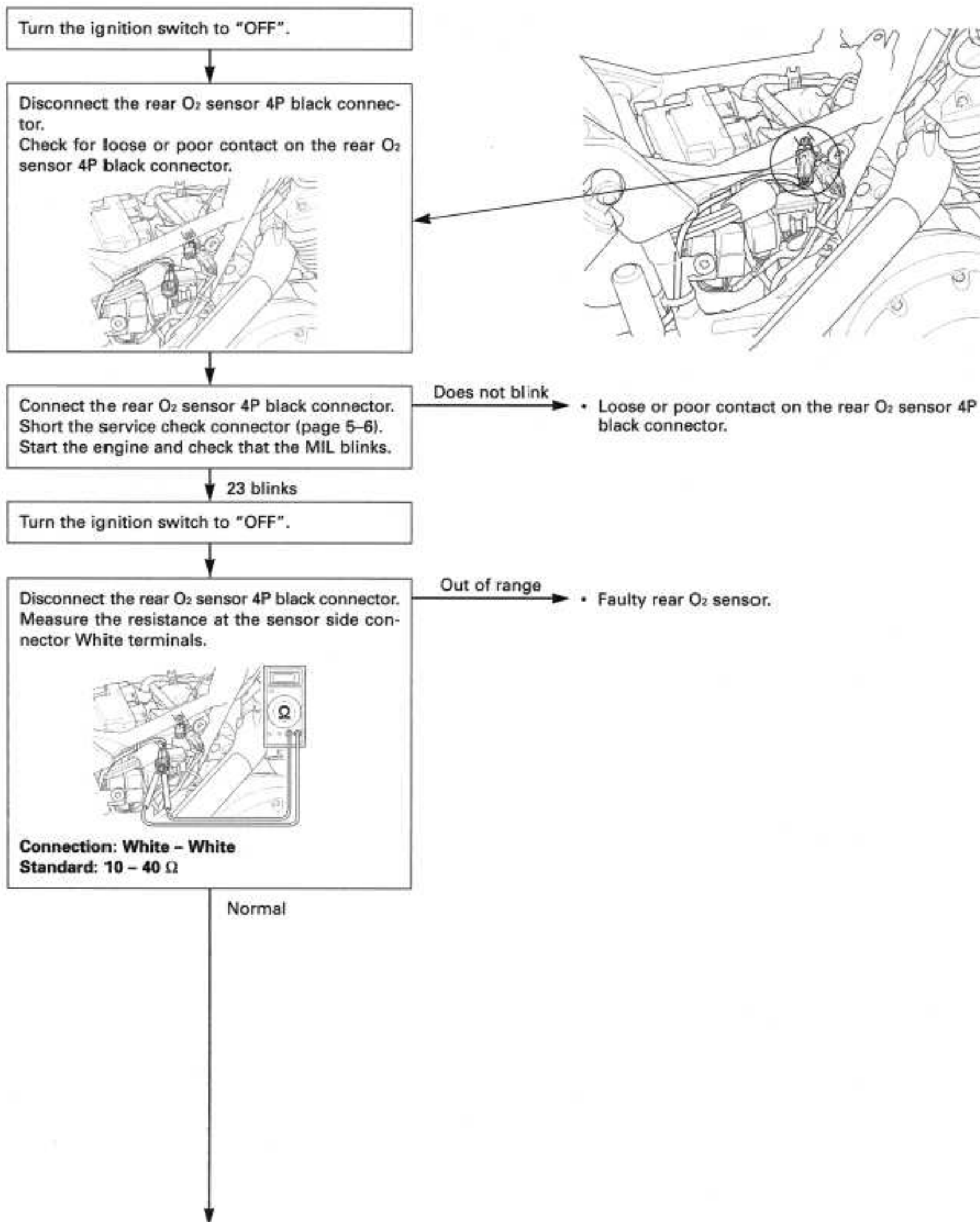



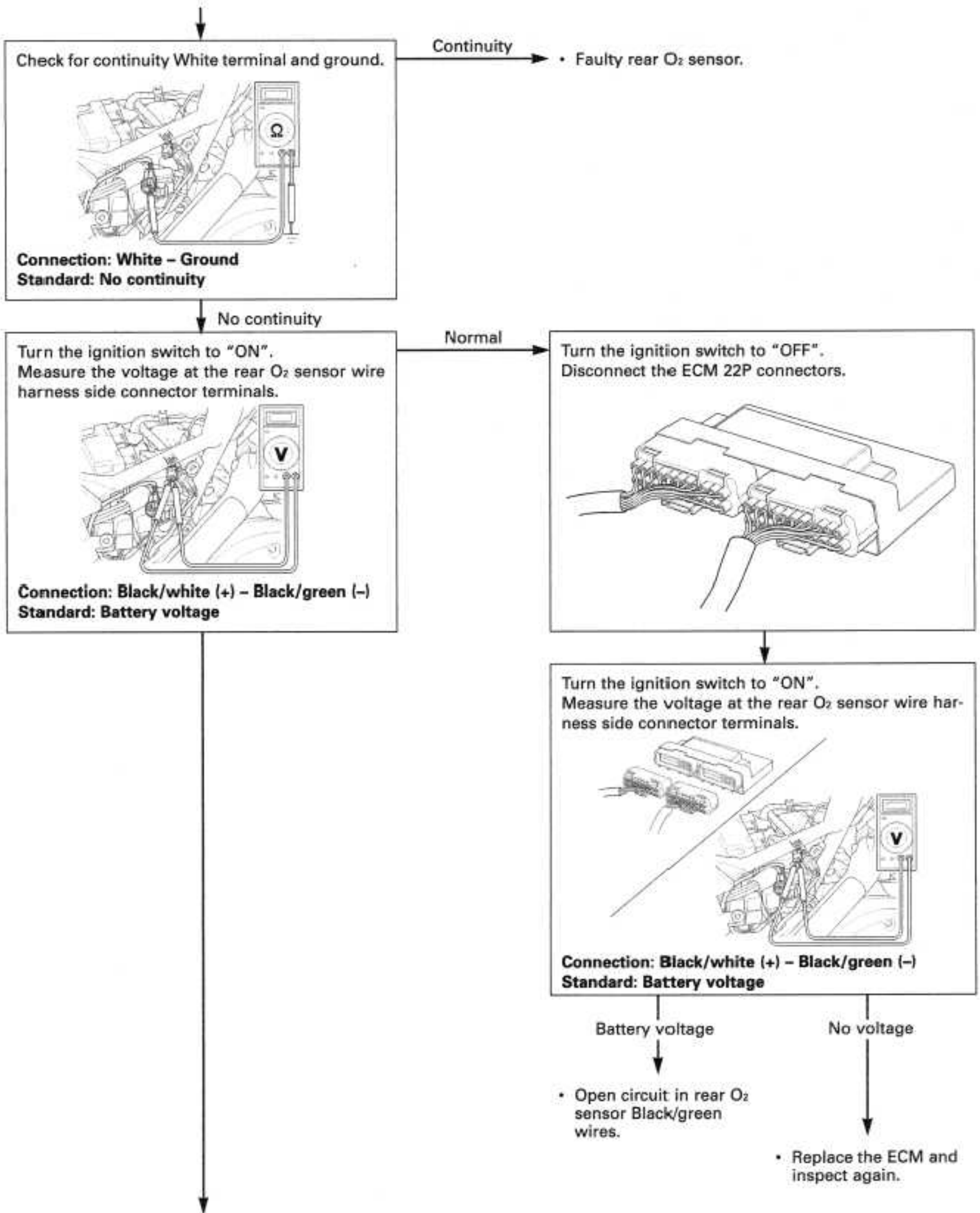

## FUEL SYSTEM (Programmed Fuel Injection)

---

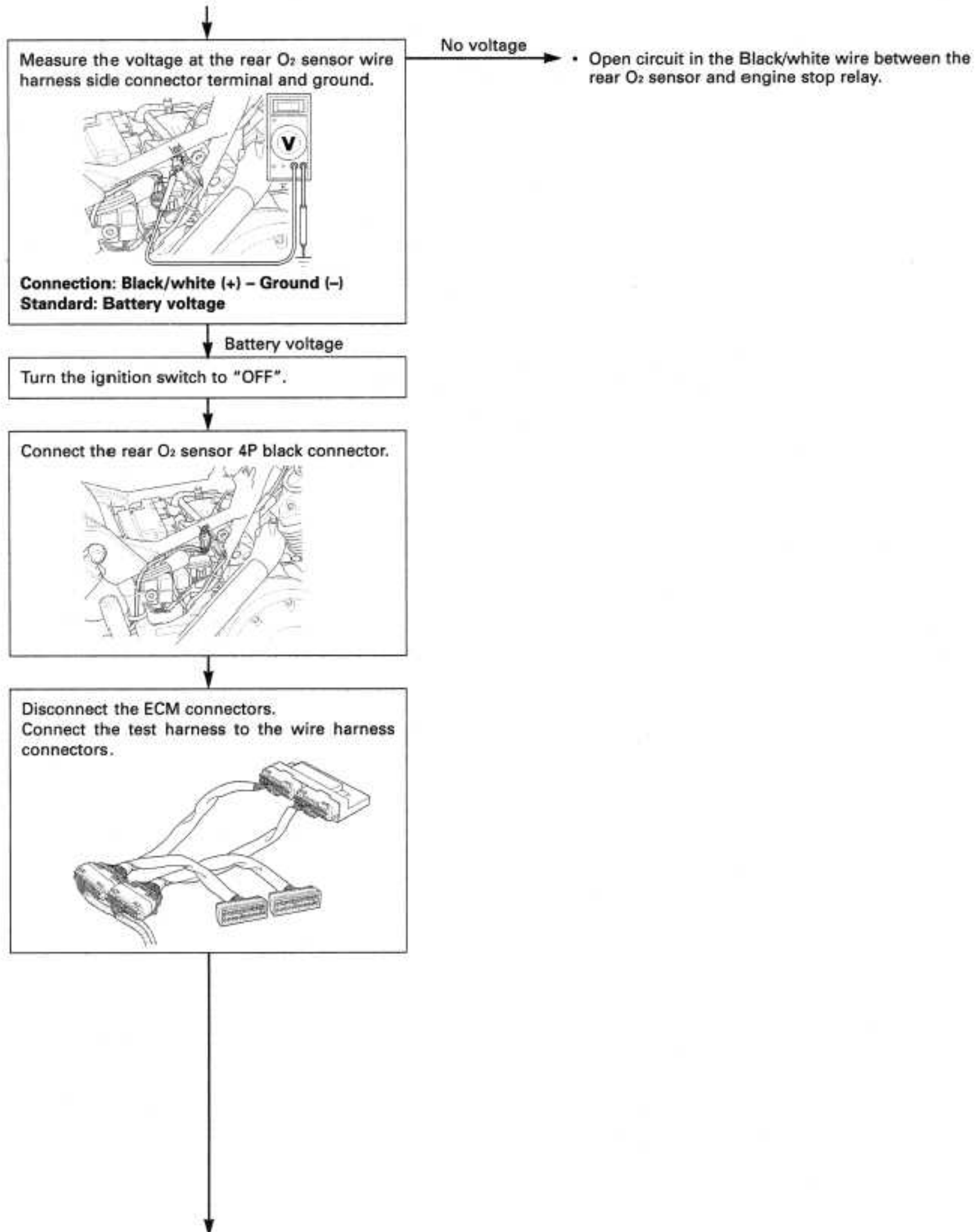

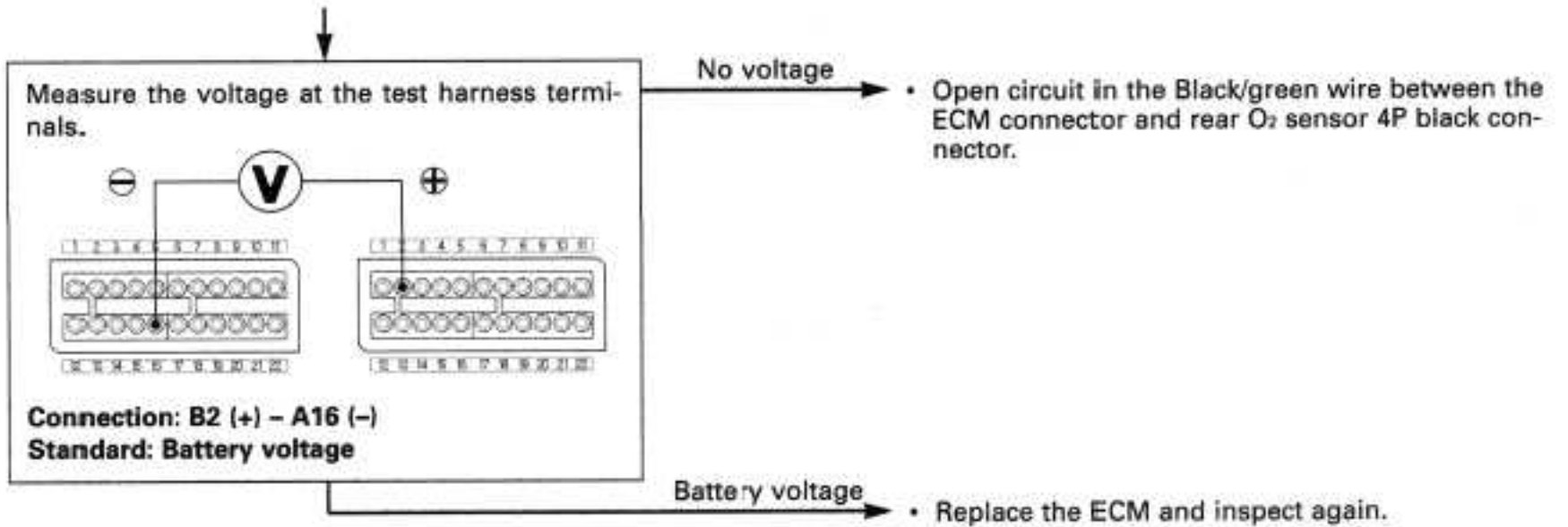

## FUEL SYSTEM (Programmed Fuel Injection)

### PGM-FI MIL 24 BLINKS (FRONT O<sub>2</sub> SENSOR HEATER/CALIFORNIA TYPE ONLY)

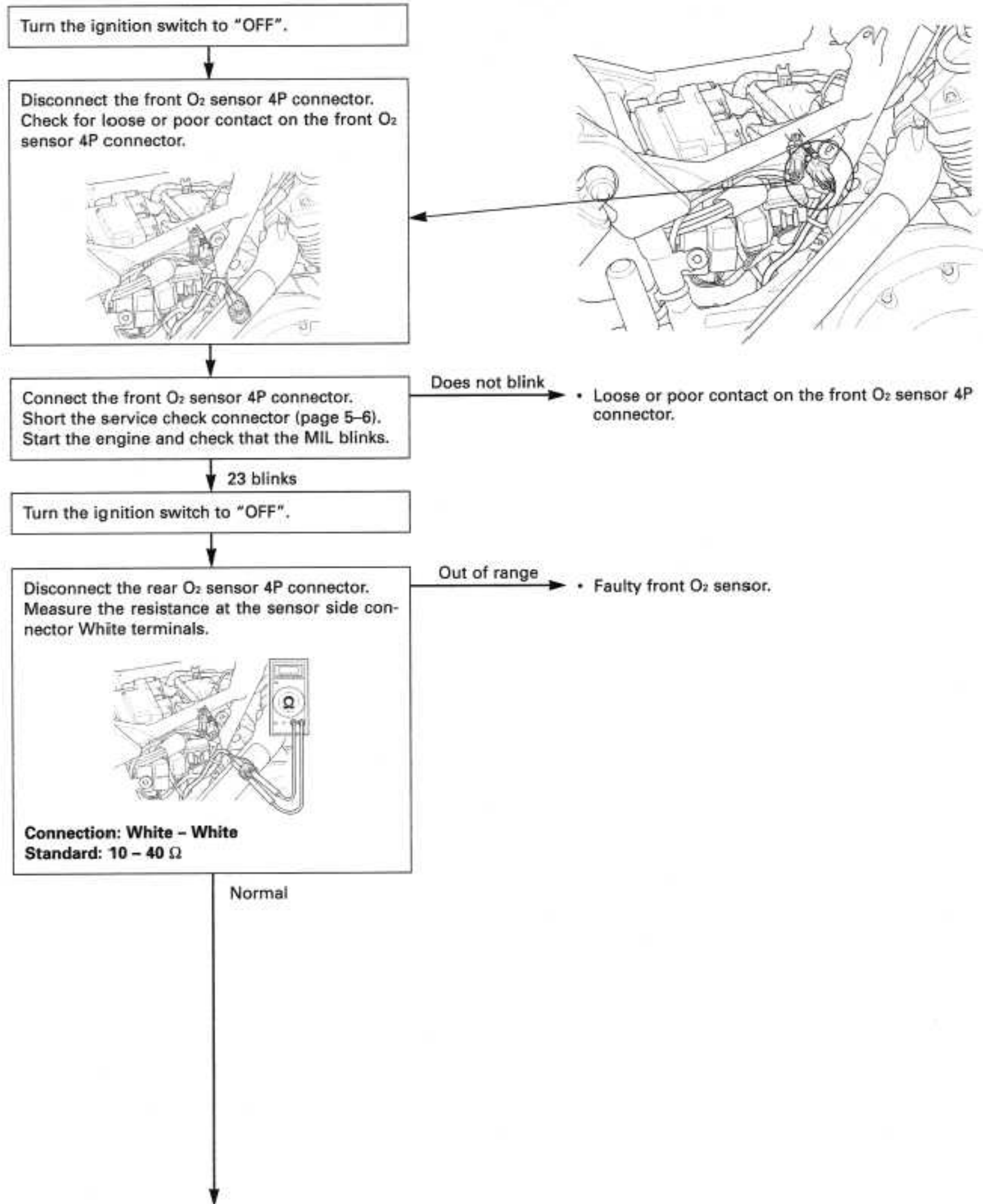

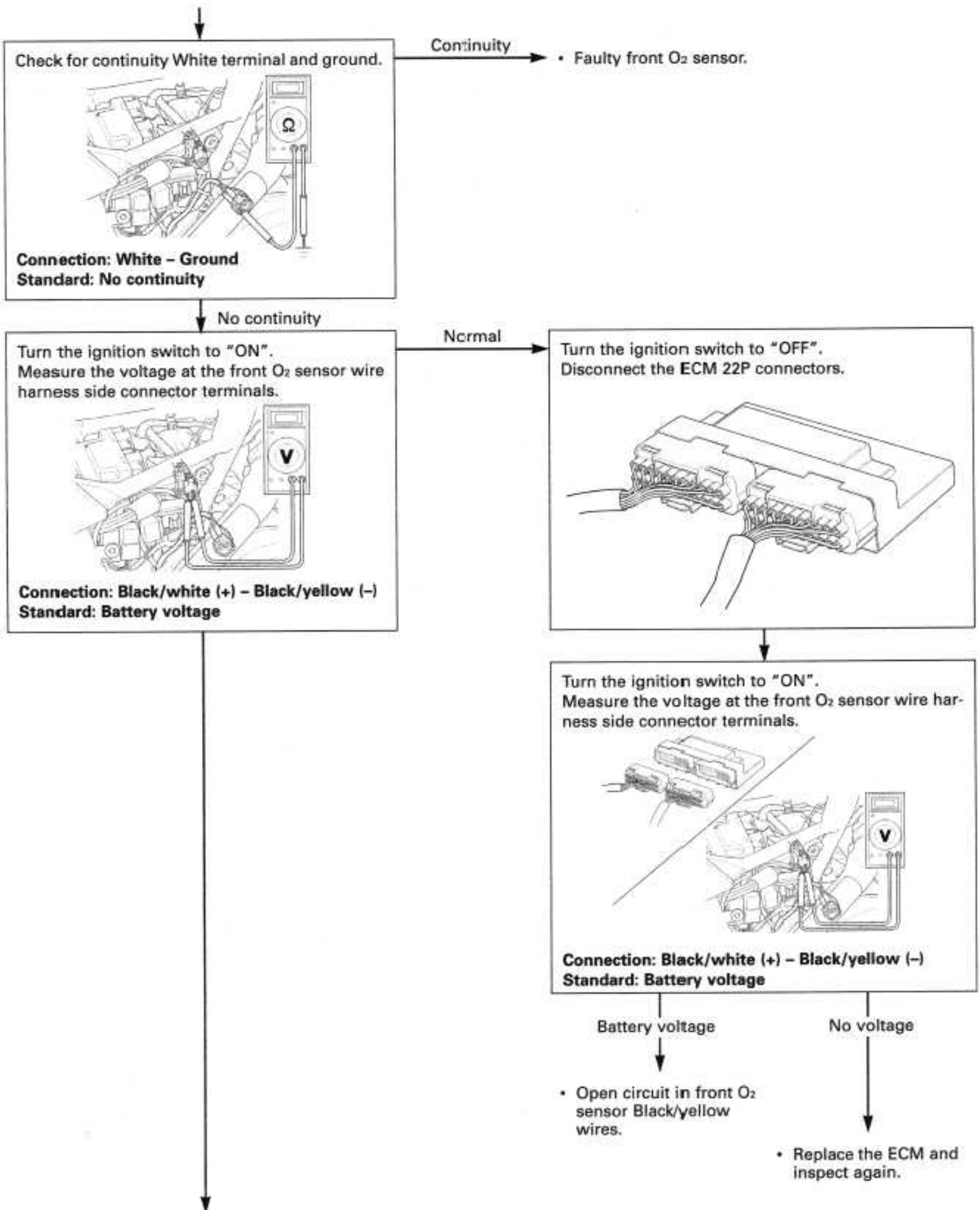



## FUEL SYSTEM (Programmed Fuel Injection)

---

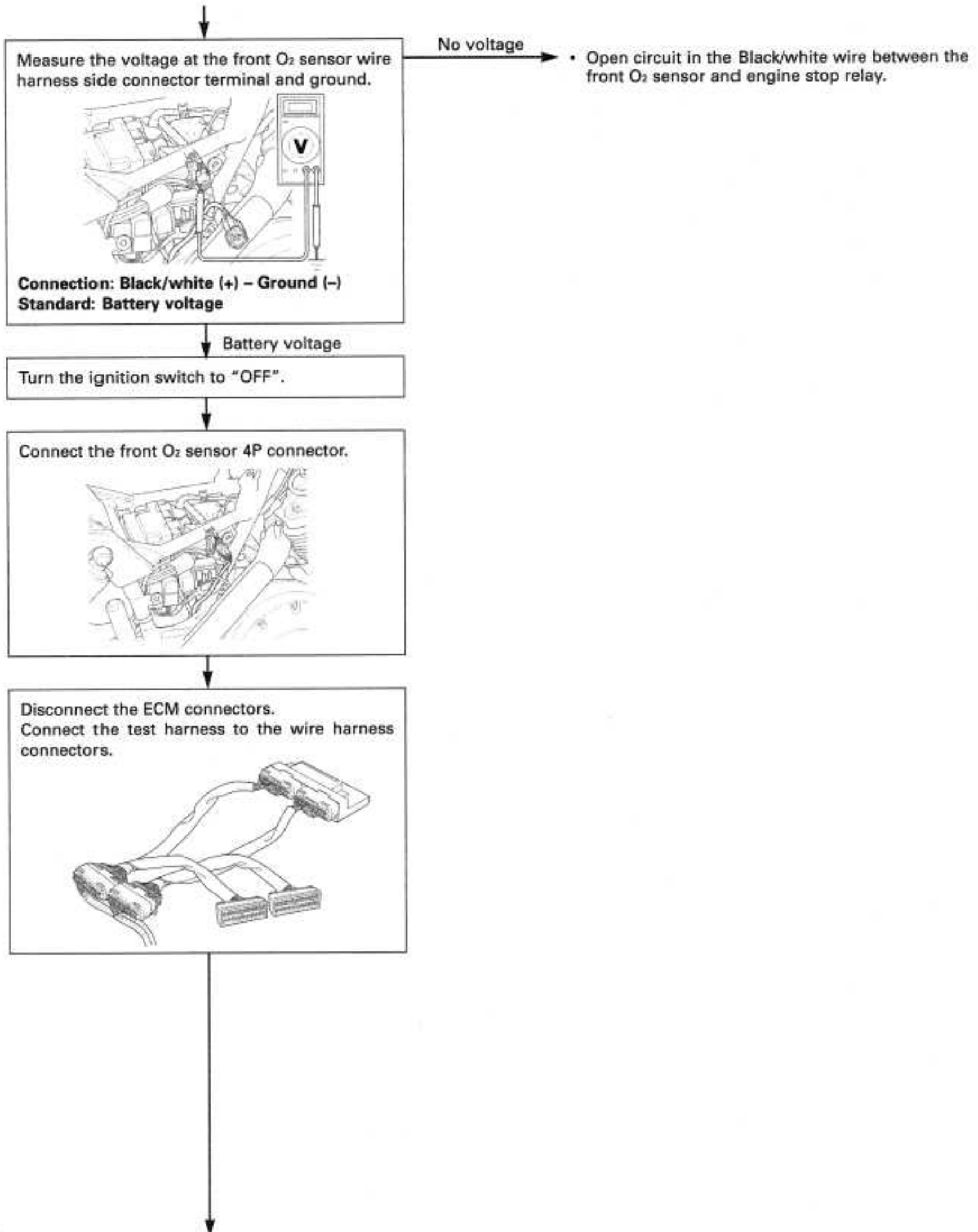

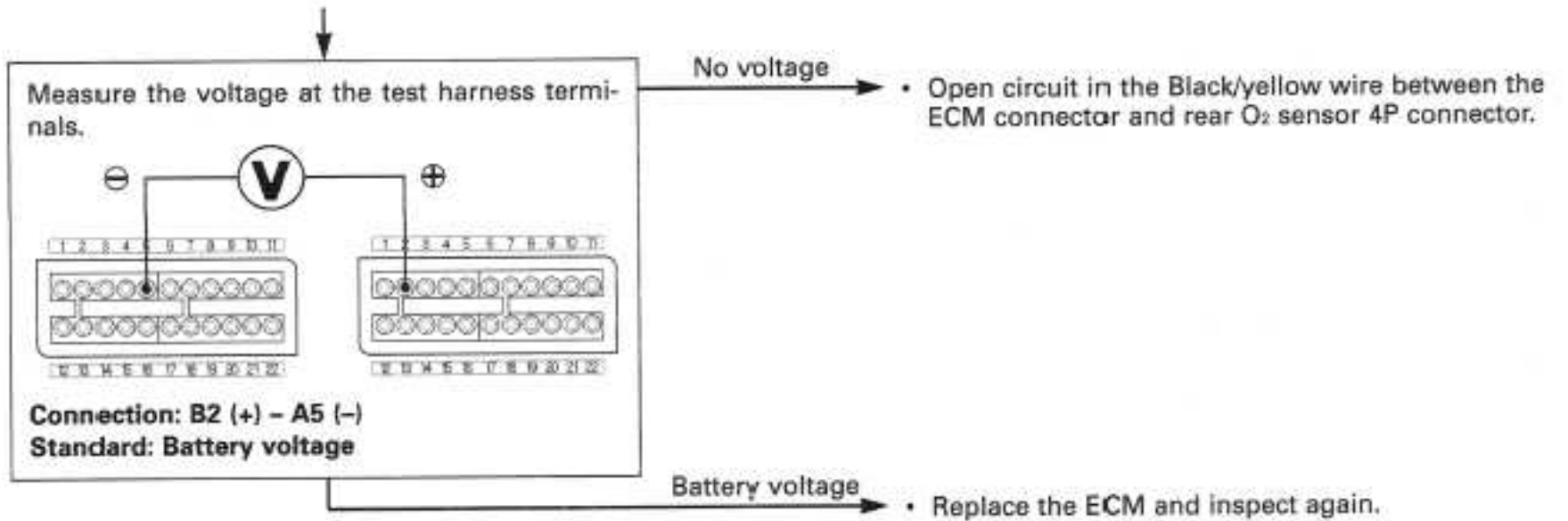

## FUEL SYSTEM (Programmed Fuel Injection)

### PGM-FI MIL 33 BLINKS (E<sup>2</sup>-PROM)

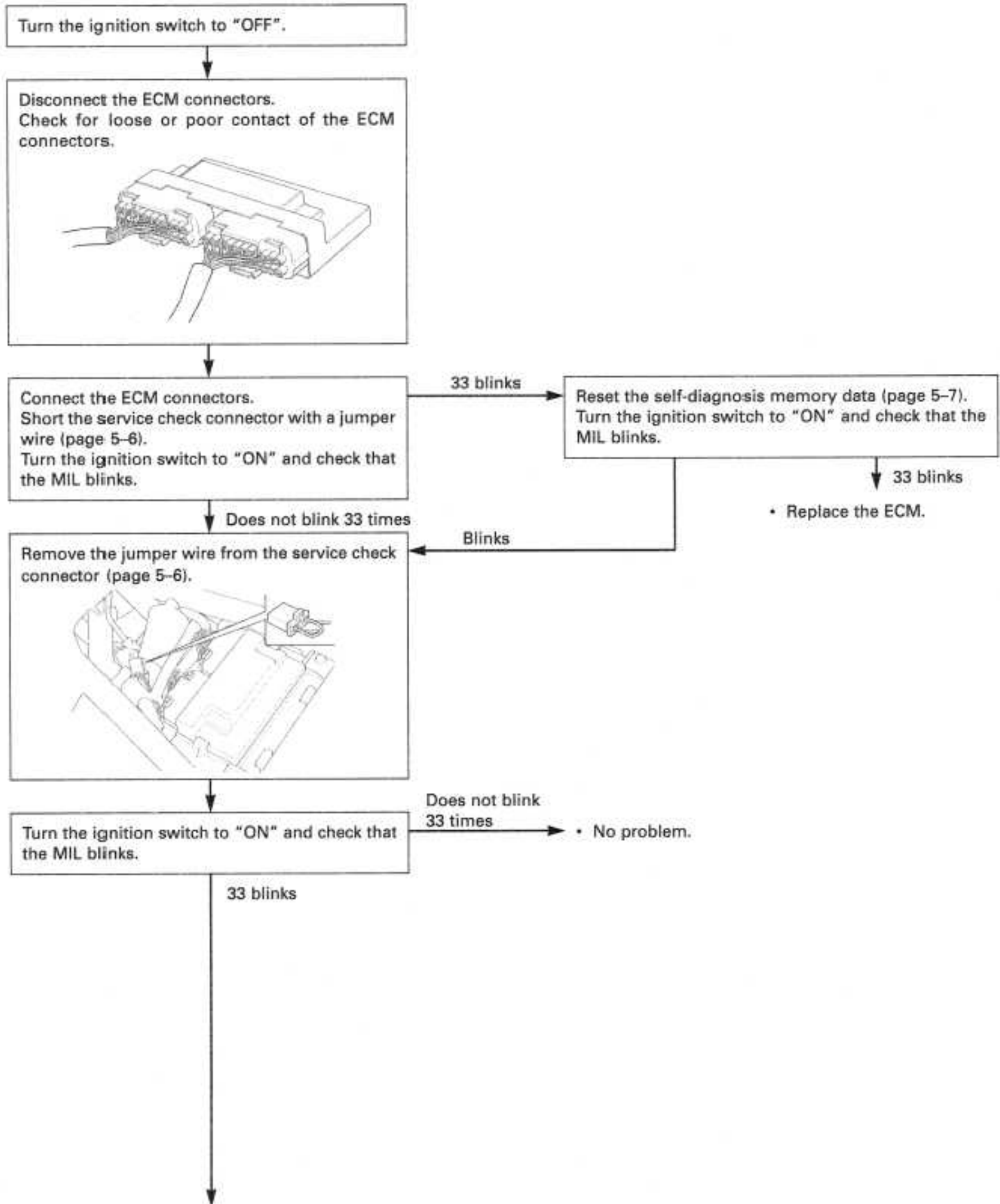

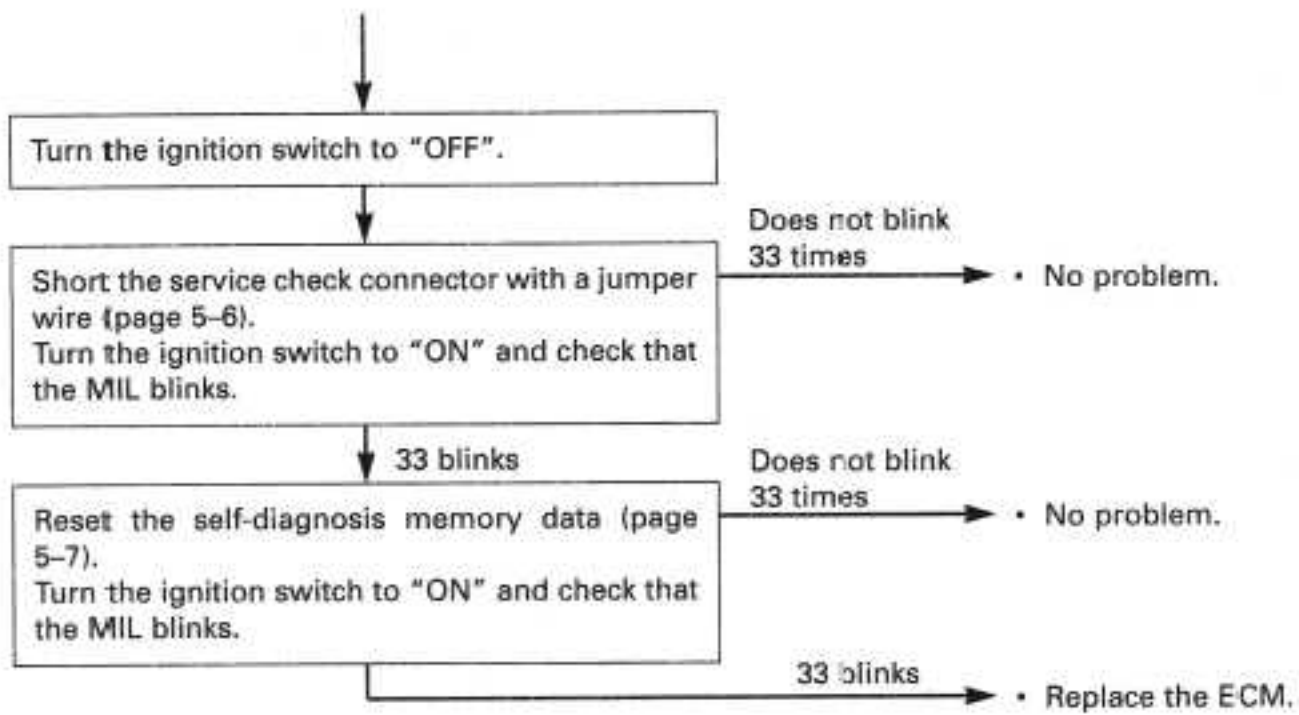

## FUEL LINE INSPECTION

### FUEL PRESSURE INSPECTION

Remove the seat (page 2-2).

Disconnect the battery negative cable from the battery terminal.

Open and support the rear end of the fuel tank (page 3-4).

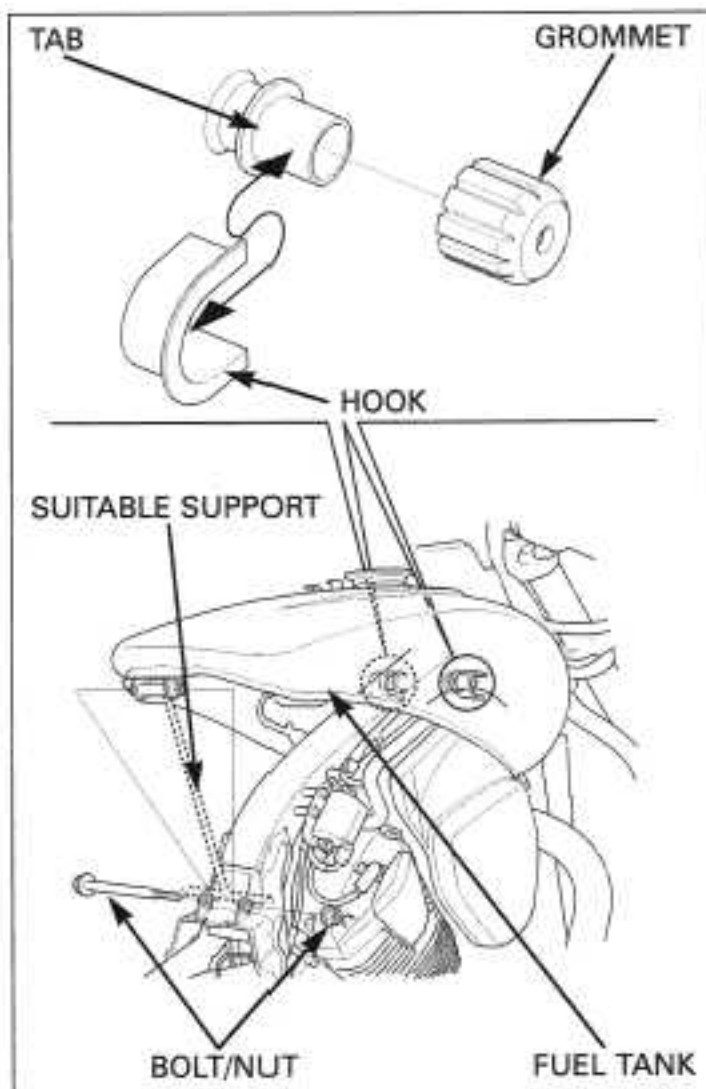

Disconnect the pressure regulator vacuum hose and plug the vacuum hose.

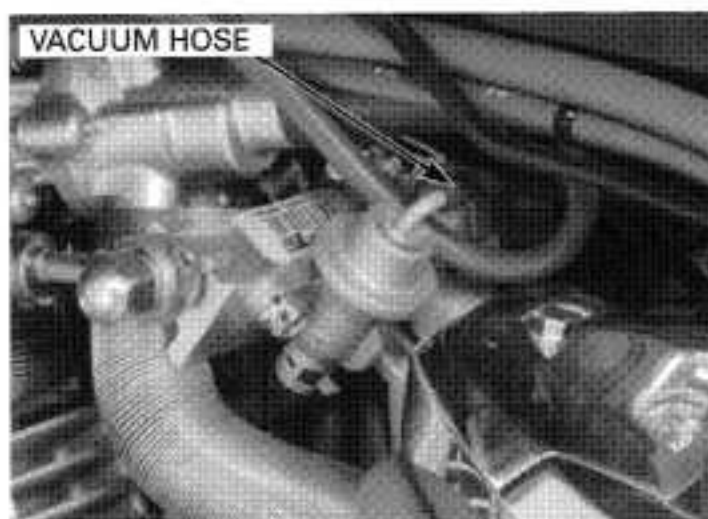

*Always replace the sealing washers when the fuel hose banjo bolt is removed or loosened.*

Cover the fuel hose banjo bolt with a shop towel.

Slowly loosen the fuel hose banjo bolt and catch the remaining fuel using an approved gasoline container.

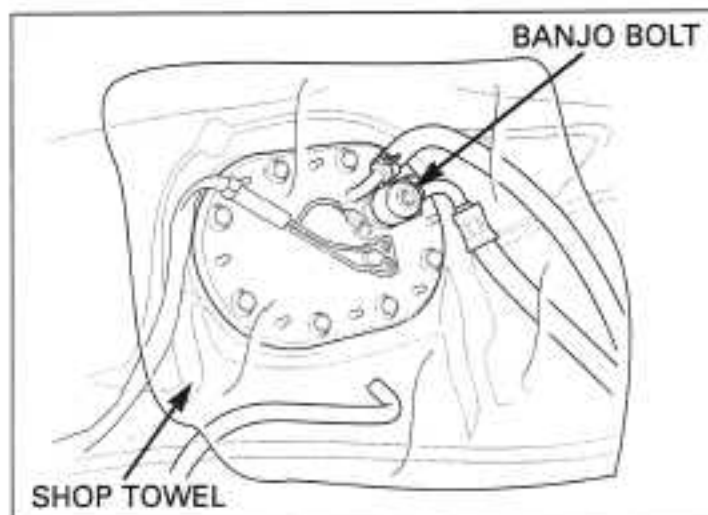



Remove the fuel hose banjo bolt and attach the fuel pressure gauge with the following Honda genuine parts.

Banjo bolt, 12 mm: Parts No. 90008-PD6-010  
 Sealing washer, 12 mm: Parts No. 90428-PD6-003  
 Sealing washer, 6 mm: Parts No. 90430-PD6-003

**TOOL:**

Fuel pressure gauge **07406-004000A**

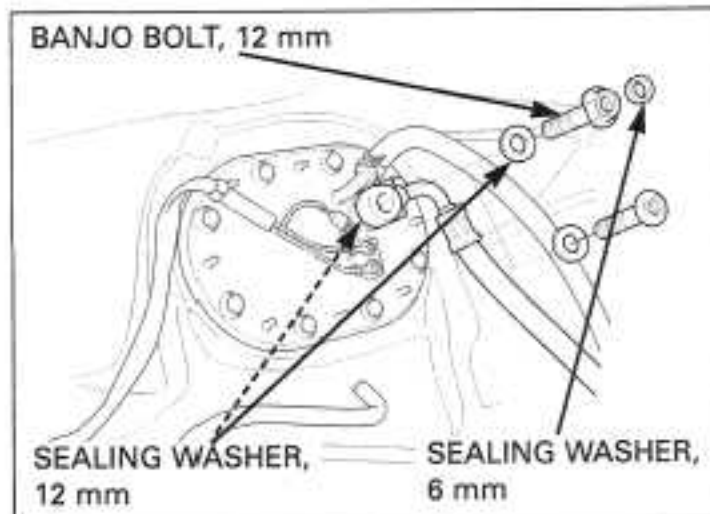

Connect the battery negative cable.  
 Start the engine and let it idle.  
 Read the fuel pressure.

**IDLE SPEED: 800 ± 100 rpm**  
**STANDARD: 343 kPa (3.5 kgf/cm<sup>2</sup>, 50 psi)**

If the fuel pressure is higher than specified, inspect the following:

- Pinched or clogged fuel return hose
- Pressure regulator
- Fuel pump (page 5-54)

If the fuel pressure is lower than the specified, inspect the following:

- Fuel line leaking
- Clogged fuel filter
- Pressure regulator
- Fuel pump (page 5-54)

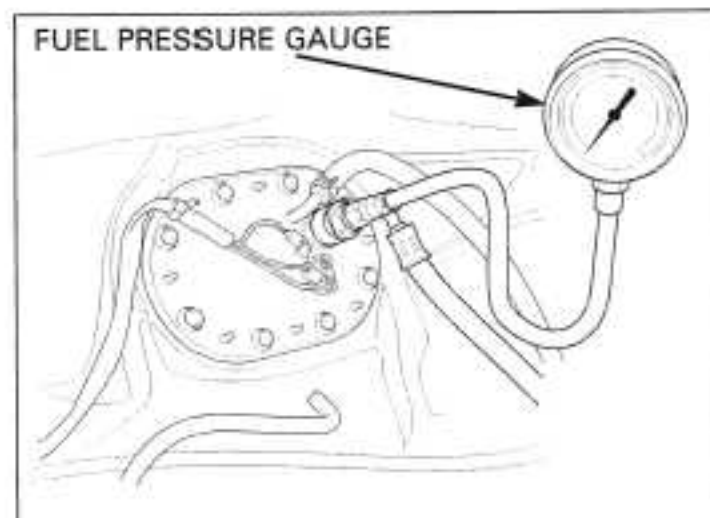

After inspection, remove the fuel hose banjo bolt and tighten the original fuel hose banjo bolt using the new sealing washers.

**TORQUE: 22 N·m (2.2 kgf·m, 16 lbf·ft)**

*Always replace the sealing washers when the fuel hose banjo bolt is removed or loosened.*

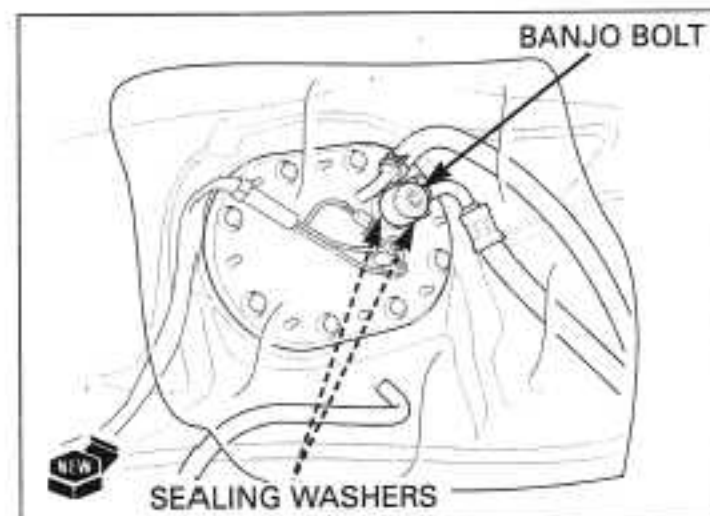

Connect the pressure regulator vacuum hose.

Install the removed parts in the reverse order of removal.

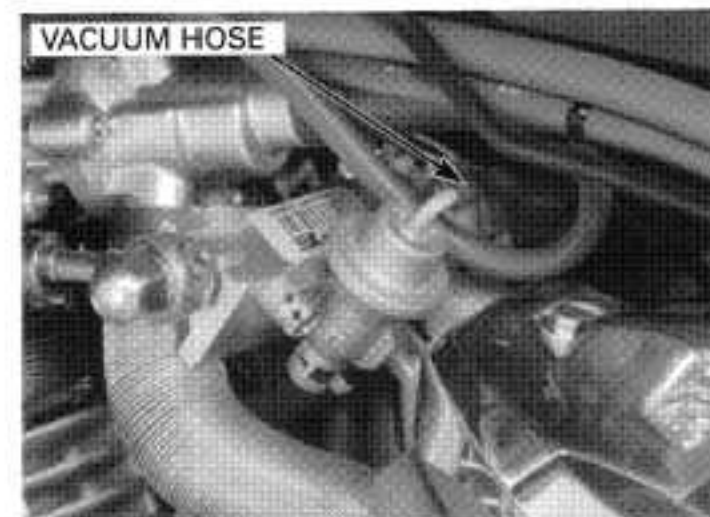

## FUEL SYSTEM (Programmed Fuel Injection)

### FUEL FLOW INSPECTION

Open and support the rear end of the fuel tank (page 3-4).

Disconnect the fuel cut-off relay 4P connector.

Jump the Brown and Black/white wire terminals of the wire harness side using a jumper wire.

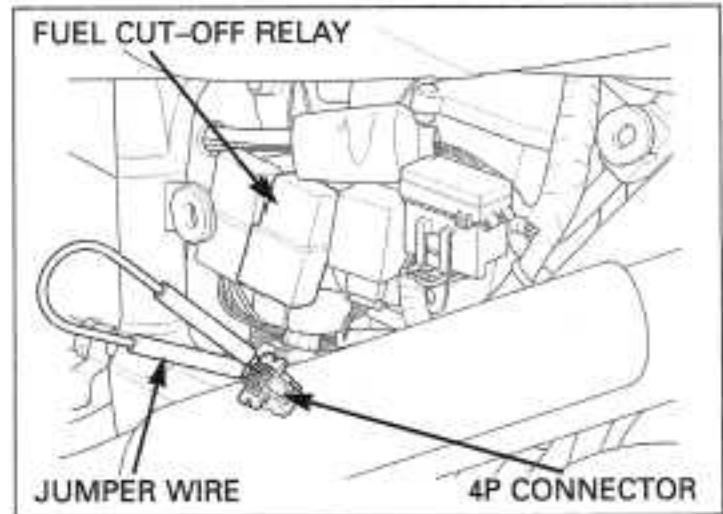

- When the fuel return hose is disconnected, gasoline will spill out. Place an approved gasoline container under the hose and drain the gasoline.
- Wipe off any spilled out gasoline.

Disconnect the fuel return hose at the pressure regulator, plug the fuel return hose.

Turn the ignition switch to "ON" for 10 seconds. Measure the amount of the fuel flow.

#### AMOUNT OF FUEL FLOW:

**188 cm<sup>3</sup> (6.4 US oz, 6.6 Imp oz) minimum/10 seconds**

If the fuel flow is less than specified, inspect the following:

- Pinched or clogged fuel hose and fuel return hose
- Clogged fuel filter
- Pressure regulator
- Fuel pump (see below)

After inspection, connect the fuel return hose to the pressure regulator.

Start the engine and check for leak.

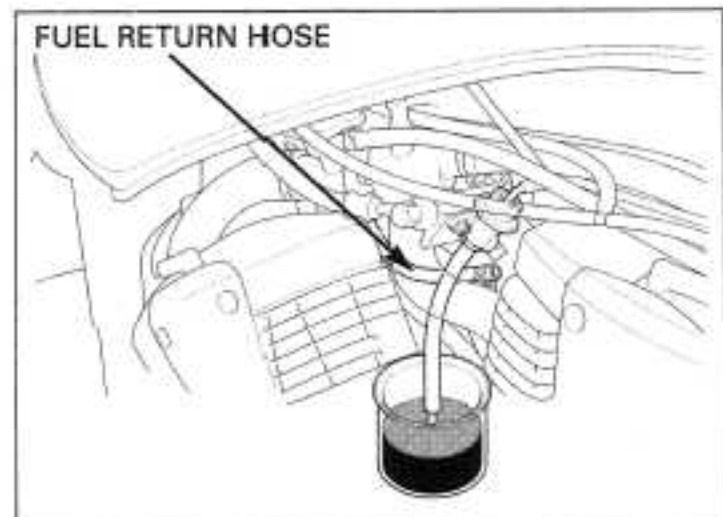

## FUEL PUMP

### INSPECTION

Turn the ignition switch to "ON" and confirm that the fuel pump operates for a few seconds.

If the fuel pump does not operate, inspect as follows:

Open and support the rear end of the fuel tank (page 3-4).

Disconnect the fuel pump 3P black connector.

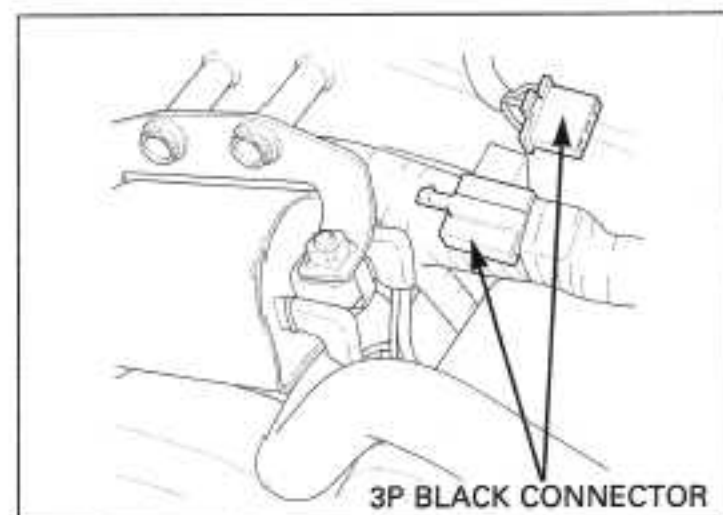

Turn the ignition switch to "ON" and measure the voltage between the terminals.

**CONNECTION: Brown (+) - Green (-)**

There should be battery voltage for a few seconds.

If there is battery voltage, replace the fuel pump. If there is no battery voltage, inspect the following:

- Main fuse 30 A
- Sub fuse 10 A
- Engine stop switch (page 19-14)
- Engine stop relay (page 5-78)
- Fuel cut-off relay (page 5-56)
- Bank angle sensor (page 5-77)
- ECM (page 5-79)

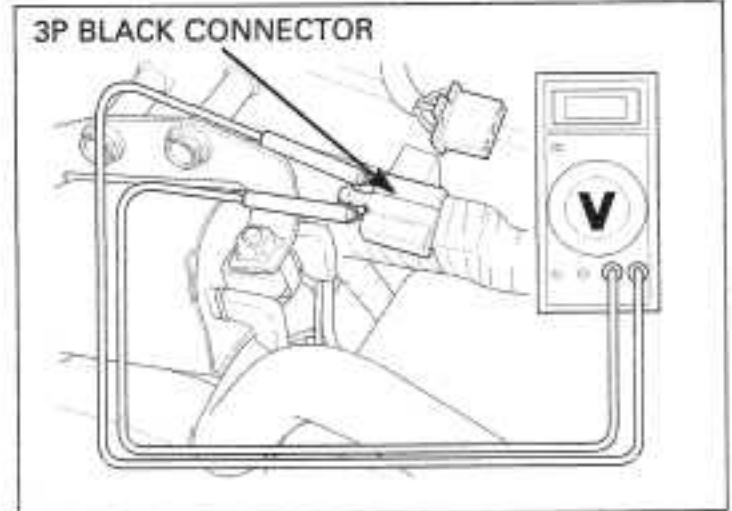

### REMOVAL

Remove the fuel tank (page 5-56).

Remove the fuel pump mounting bolts.

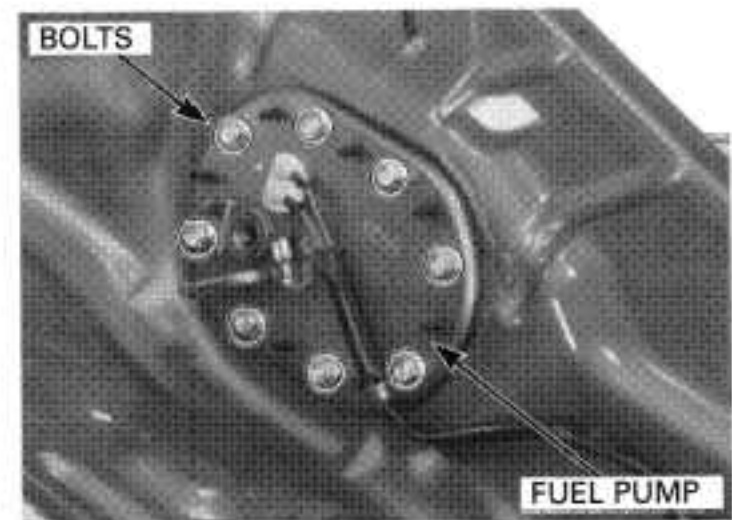

Remove the fuel pump assembly and packing.

### FUEL FILTER REPLACEMENT

Disconnect the fuel hoses from the fuel filter. Remove the screw and fuel filter.

Install the fuel filter in the reverse order of removal.

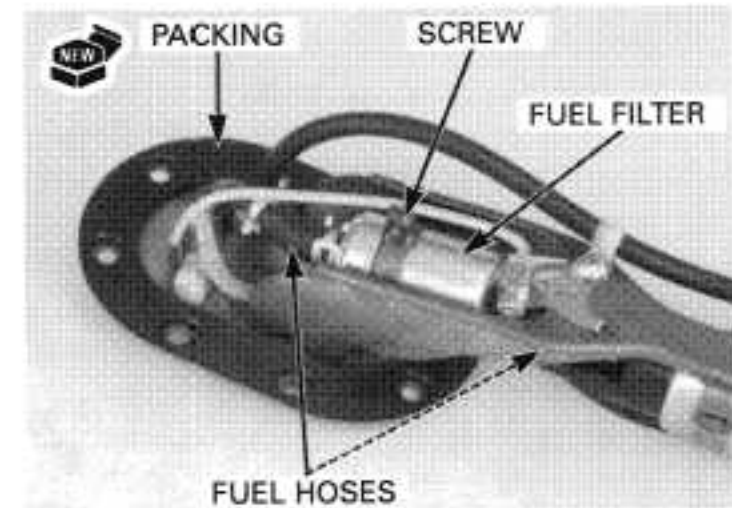

### INSTALLATION

Place a new packing onto the fuel tank.

Install the fuel pump being careful not to damage the fuel pump wire.

Install and tighten the fuel pump mounting nuts in the sequence shown.

**TORQUE: 12 N·m (1.2 kgf·m, 9 lbf·ft)**

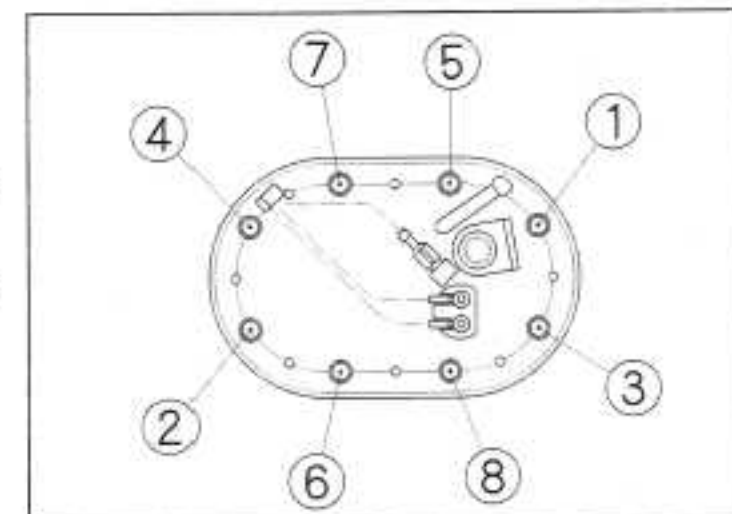

*Always replace the sealing washers when the fuel hose banjo bolt is removed or loosened.*

*Note the direction of the fuel filter.*

*Always replace the packing with a new one.*

### FUEL CUT-OFF RELAY

#### INSPECTION

Remove the right side cover (page 2-2).

Disconnect the fuel cut-off relay 4P connector, then remove the fuel cut-off relay.

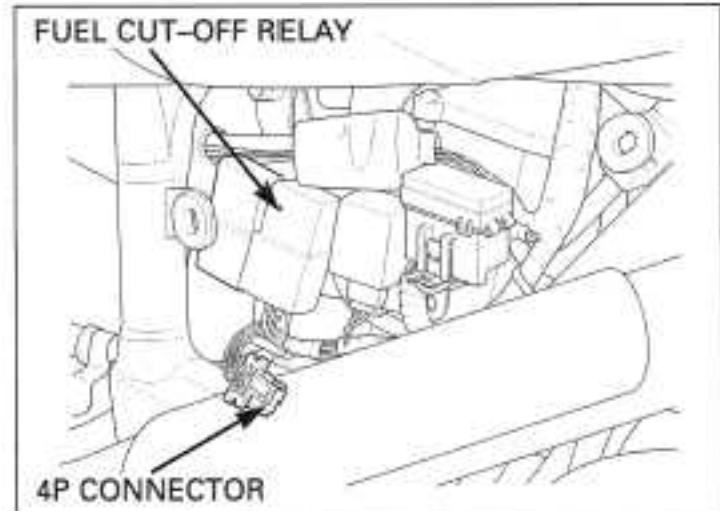

Connect the ohmmeter to the fuel cut-off relay connector terminals.

**CONNECTION: Black/white – Brown**

Connect the 12-V battery to the following fuel cut-off relay connector terminals.

**CONNECTION: Brown/black – Black/white**

There should be continuity only when the 12-V battery is connected.

If there is no continuity when the 12-V battery is connected, replace the fuel cut-off relay.

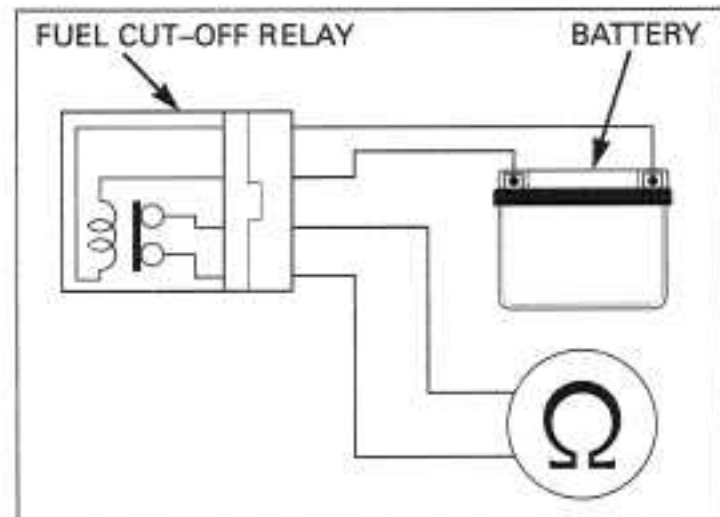

### FUEL TANK

#### REMOVAL

Disconnect the fuel pump 3P black connector.

Open and support the rear end of the fuel tank (page 3-4).

#### NOTICE

*Do not apply excessive force to the fuel pipe.*

Disconnect the fuel tank breather hose from the fuel tank.

Disconnect the fuel return hose from the pressure regulator and drain the fuel.

Remove the fuel hose sealing nut, sealing washers and fuel hose.

Close the fuel tank and drain the fuel from the fuel tank.

Remove the fuel tank from the frame.

#### INSTALLATION

Installation is in the reverse order of removal.

**TORQUE: 12 N·m (1.2 kgf·m, 9 lbf·ft)**

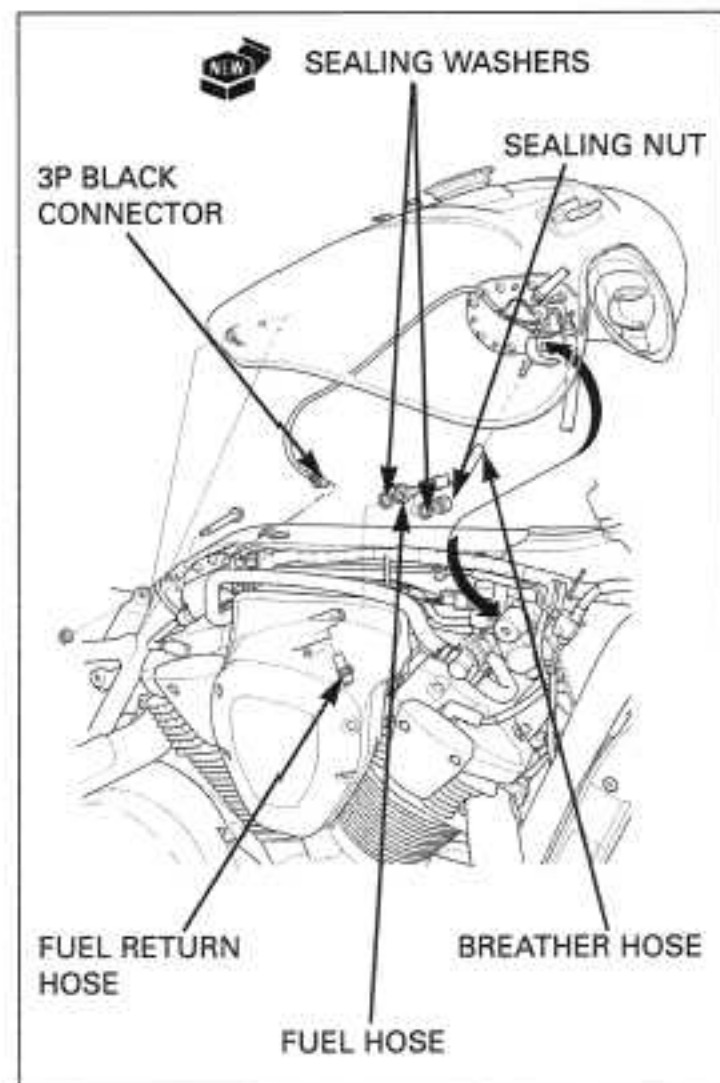

*Always replace the sealing washers when the fuel hose banjo bolt is removed or loosened.*



## AIR CLEANER HOUSING

### REMOVAL

Open and support the rear end of the fuel tank (page 3-4).

Remove the air cleaner element (page 3-5).

Disconnect the intake duct control hose.



Remove the screws and air funnel from the air cleaner housing.

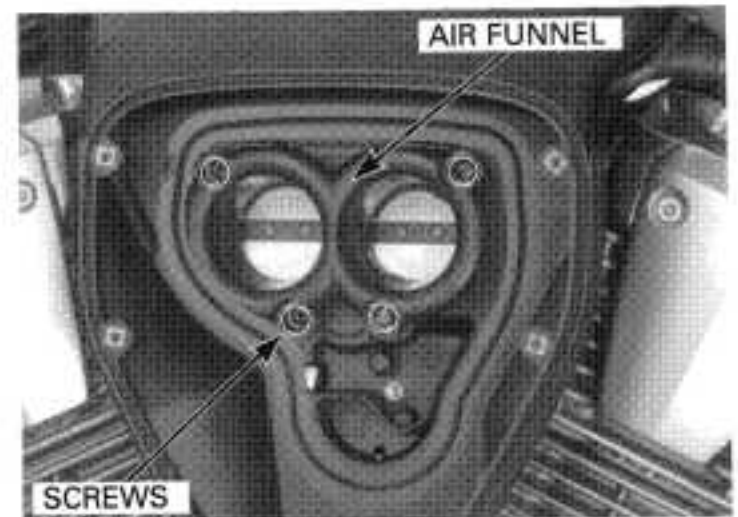

Remove the tab on the air cleaner housing from the grommet on the stay, then remove the air cleaner housing.

Disconnect the breather hose and intake air hose from the air cleaner housing.  
Disconnect the IAT sensor 2P connector.

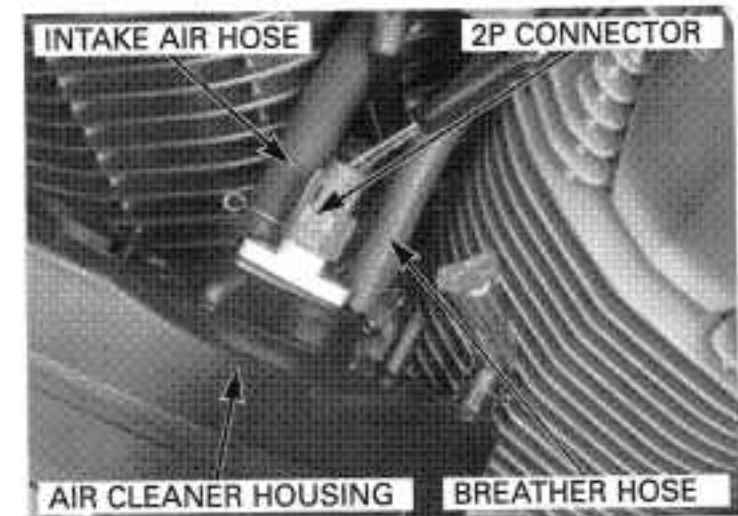

### INSTALLATION

Installation is in the reverse order of removal.

Install the air cleaner element (page 3-5).



### THROTTLE BODY

#### THROTTLE BODY REMOVAL

Drain the coolant from the cooling system (page 6-5).

*Always replace the sealing washers when the fuel hose banjo bolt is removed or loosened.*

Remove the following:

- Fuel tank (page 5-56)
- Air cleaner housing (page 5-57)

Remove the throttle stop screw from the guide.

Disconnect the TP sensor 3P gray connector and MAP sensor 3P black connector.

Loosen the band screw and disconnect the water hose.

Remove the sub-harness from the clamp.  
Remove the bolts, clamp and throttle body.  
Remove the O-ring.

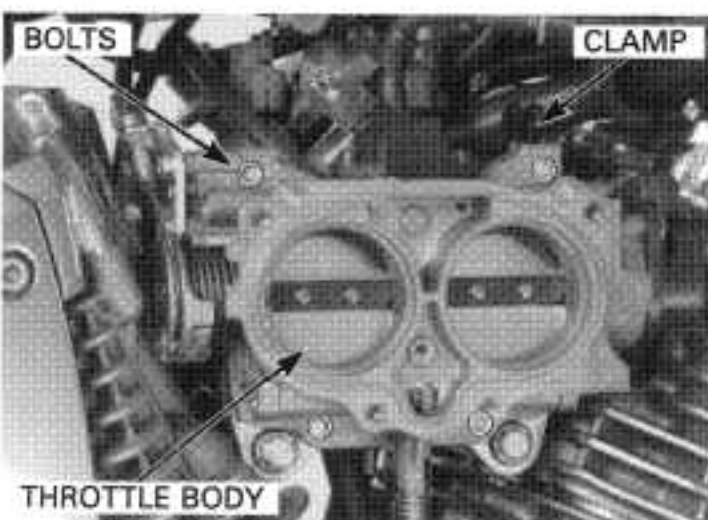
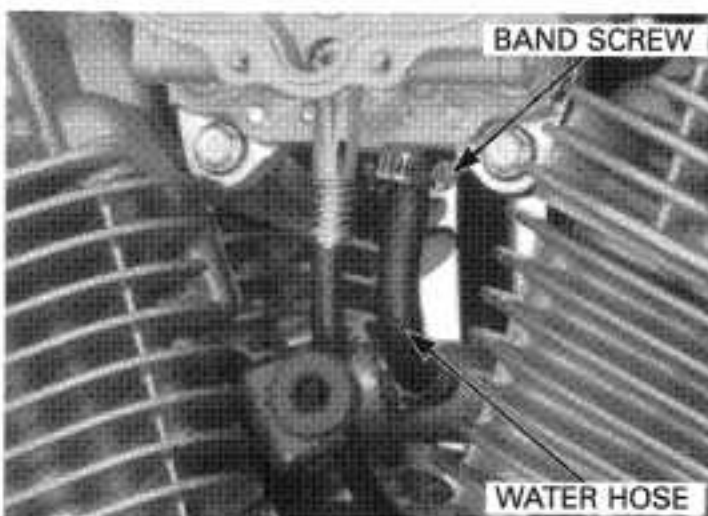

Do not snap the throttle valve from fully open to fully closed after the throttle cable has been removed. It may cause incorrect idle operation.

Loosen the lock nuts and disconnect the throttle cables from the throttle drum.

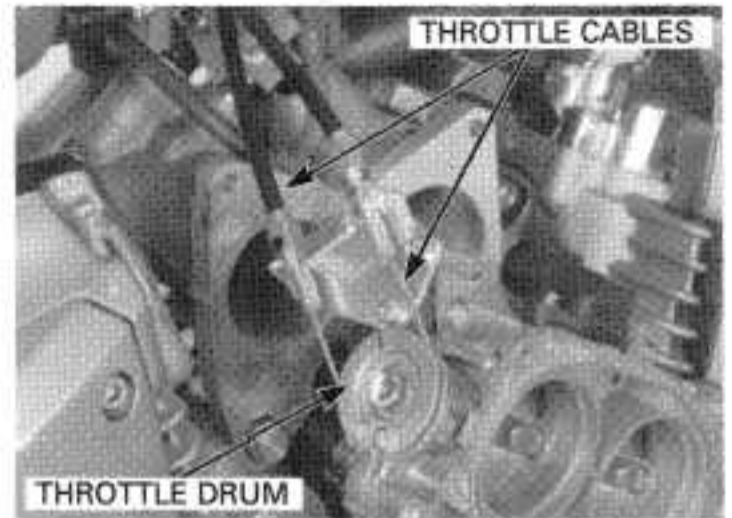

Loosen the band screw and disconnect the water hose.

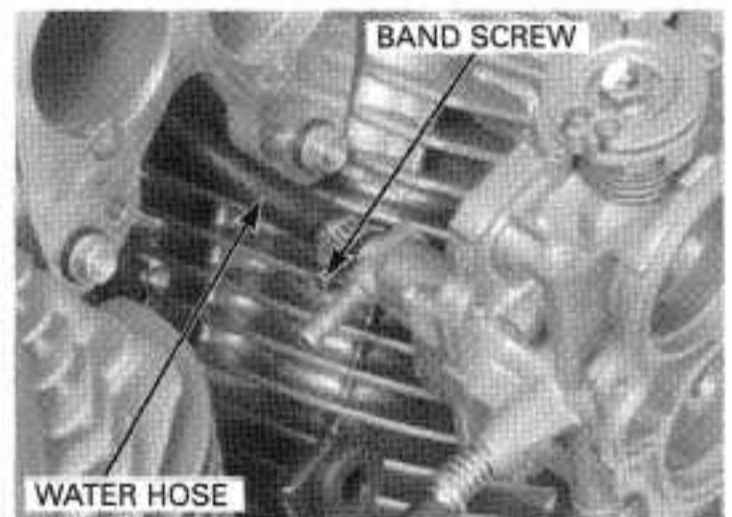

### NOTICE

- Do not damage the throttle body. It may cause incorrect throttle and idle valve synchronization.
- The throttle body is factory pre-set. Do not disassemble in a way other than shown in this manual.
- Do not loosen or tighten the white painted bolts and screws of the throttle body. Loosening or tightening them can cause throttle and idle valve synchronization failure.

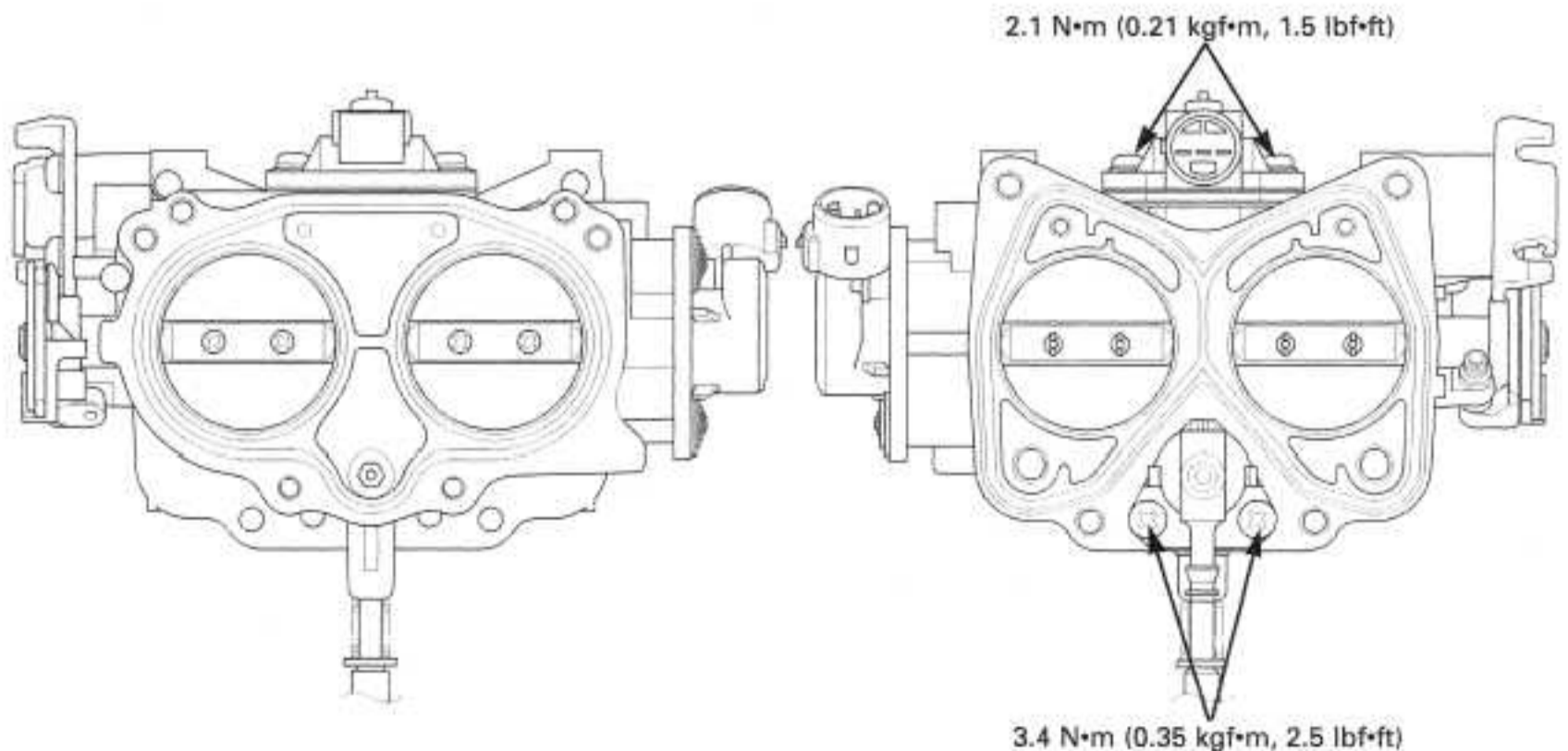

## FUEL SYSTEM (Programmed Fuel Injection)

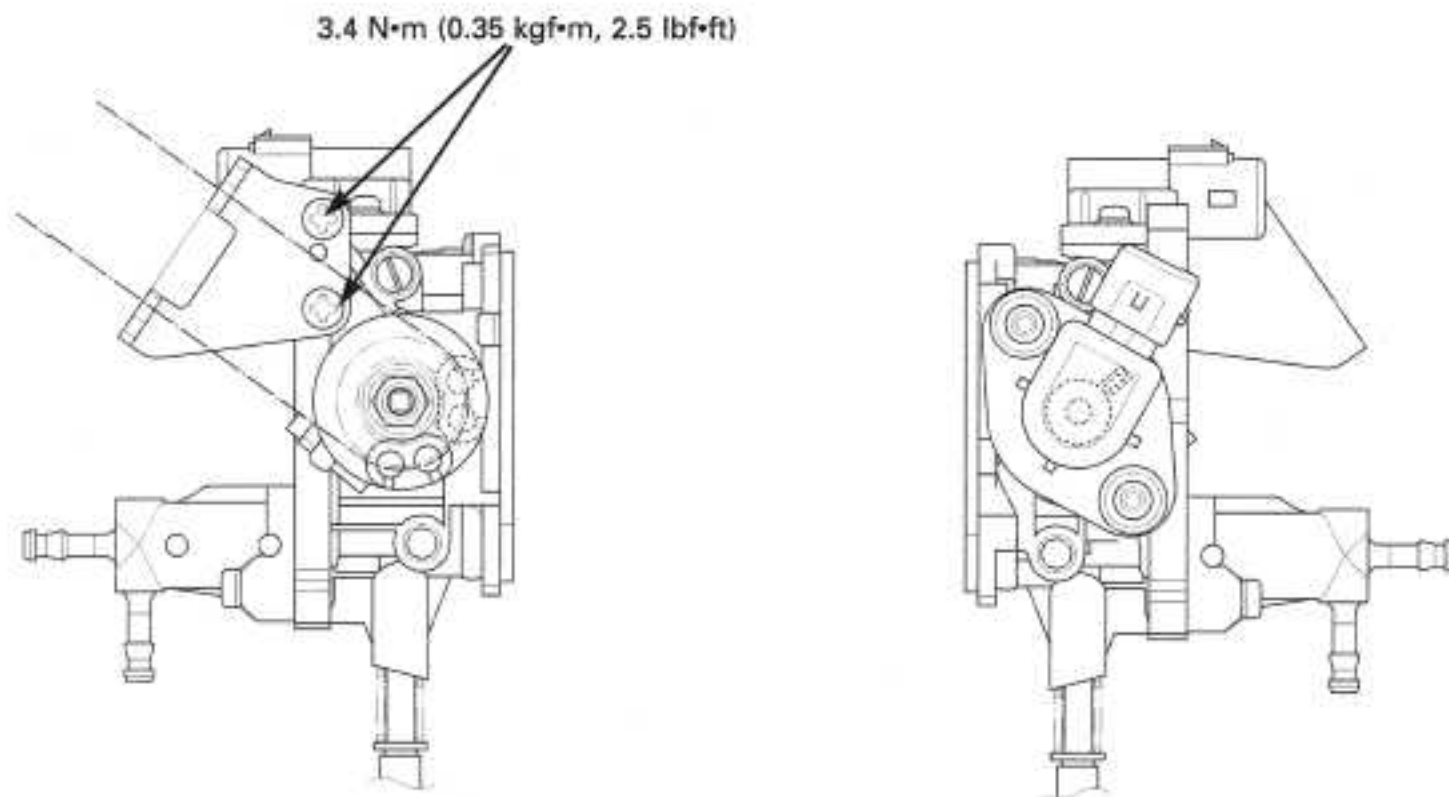

### INTAKE MANIFOLD REMOVAL

Remove the throttle body (page 5-58).

Disconnect the front injector 2P brown connector and rear injector 2P gray connector.

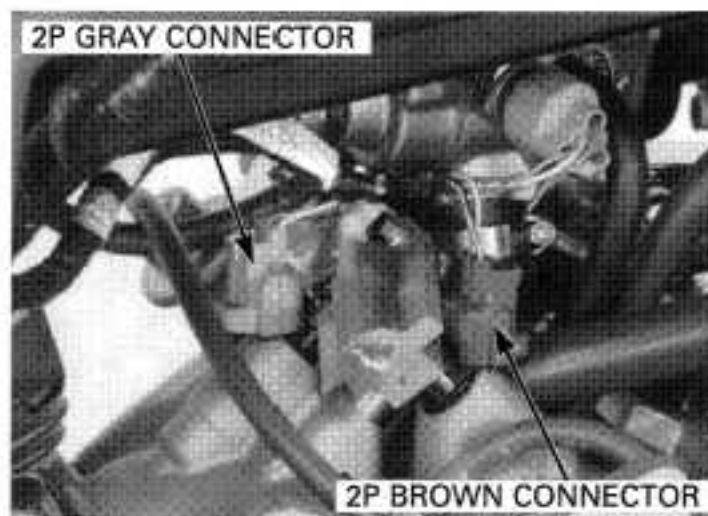

Disconnect the intake duct control solenoid valve hose from the intake manifold.

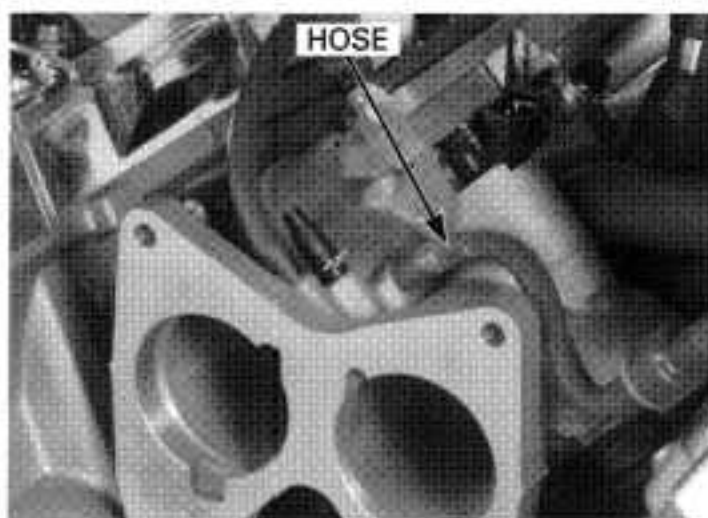

Loosen the rear insulator band screw.

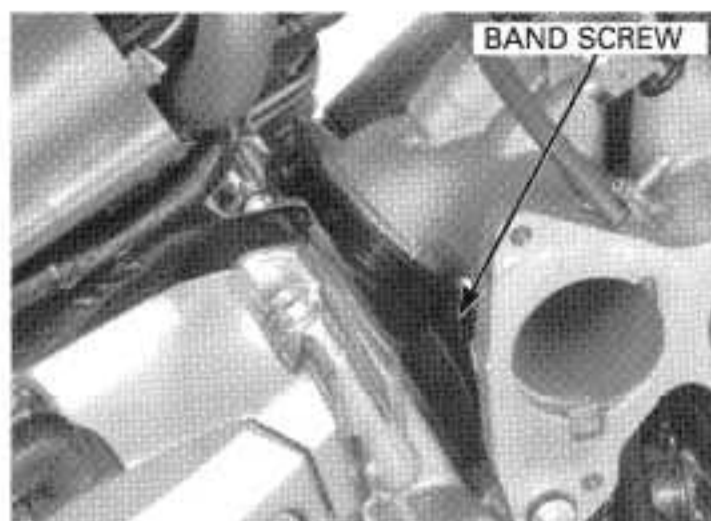

Loosen the front insulator band screw.

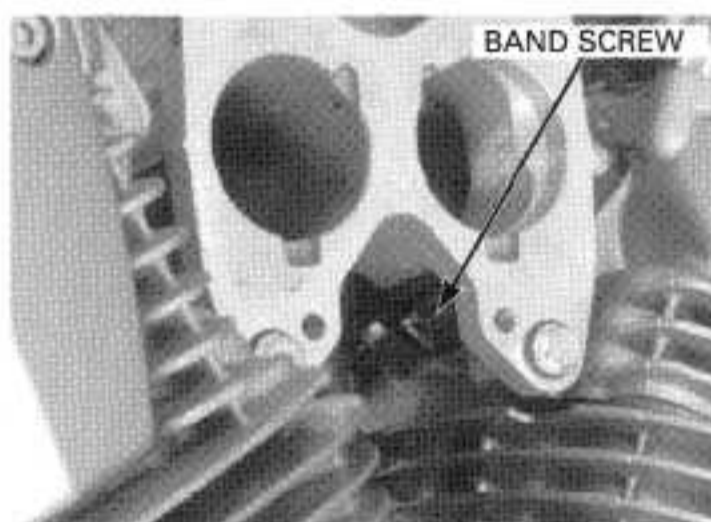

Remove the bolts and intake manifold assembly.

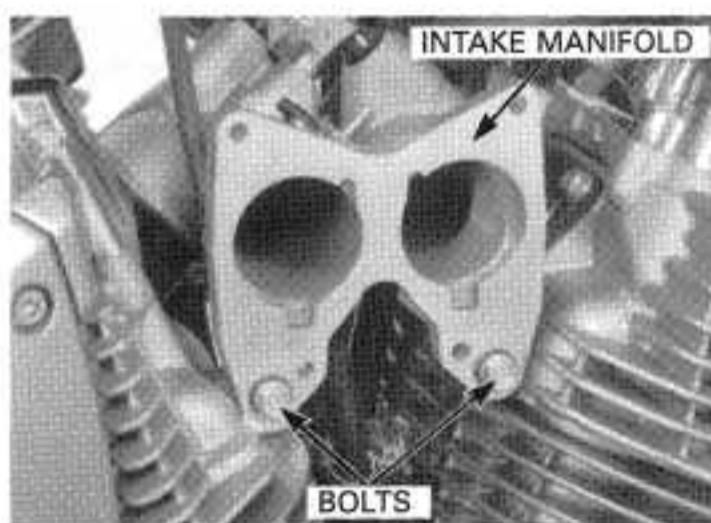

Remove the socket bolts and front and rear insulator.  
Remove the O-rings from the insulator grooves.

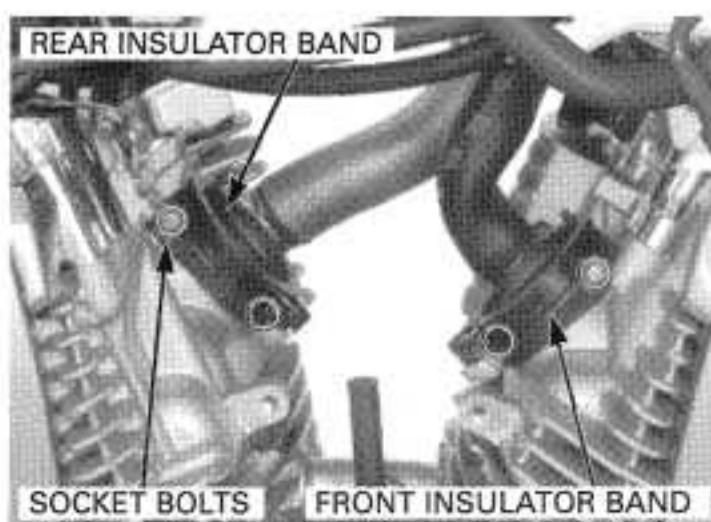



### INTAKE MANIFOLD INSTALLATION

Check the collars for wear or damage.  
Check the rubbers for wear or damage.

Replace them if necessary.

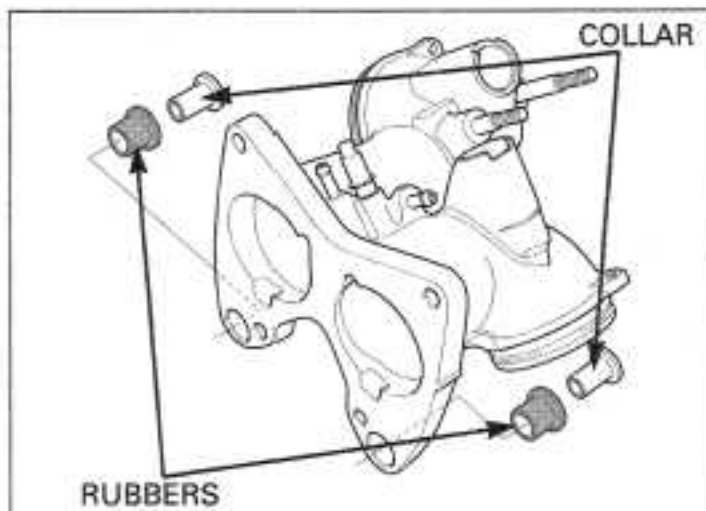

Install a new O-rings to the front and rear insulator grooves.

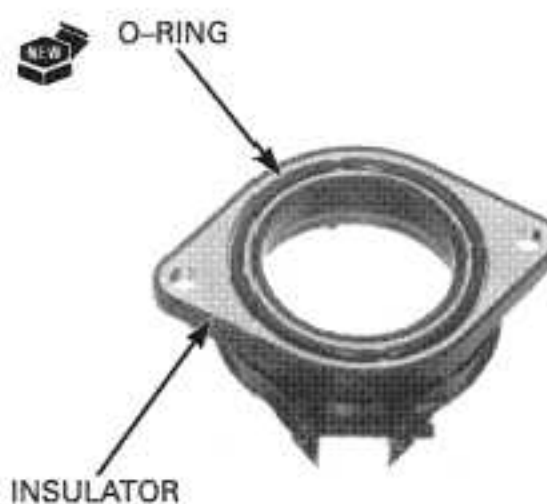

Install the front insulator to the cylinder head and tighten the socket bolts securely.

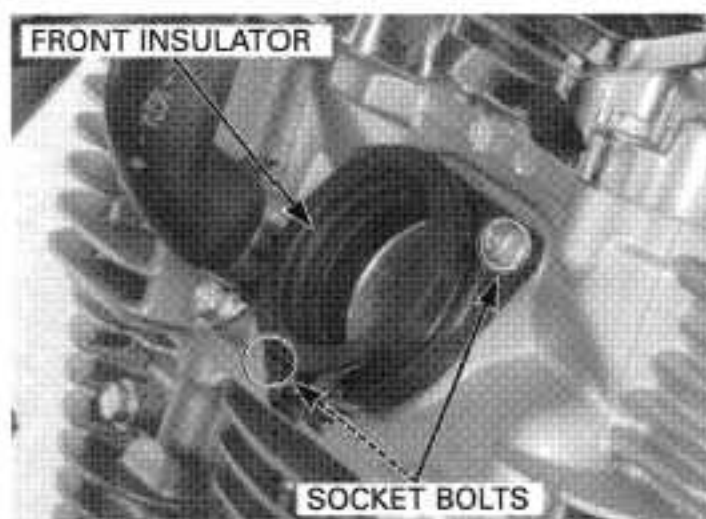

*Do not tighten the insulator band screw yet.*

Install the rear insulator to the intake manifold.

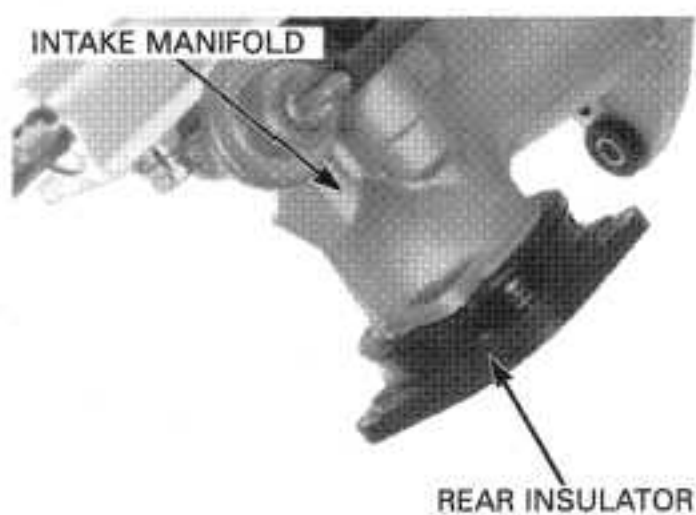



Install the intake manifold to the front insulator securely.

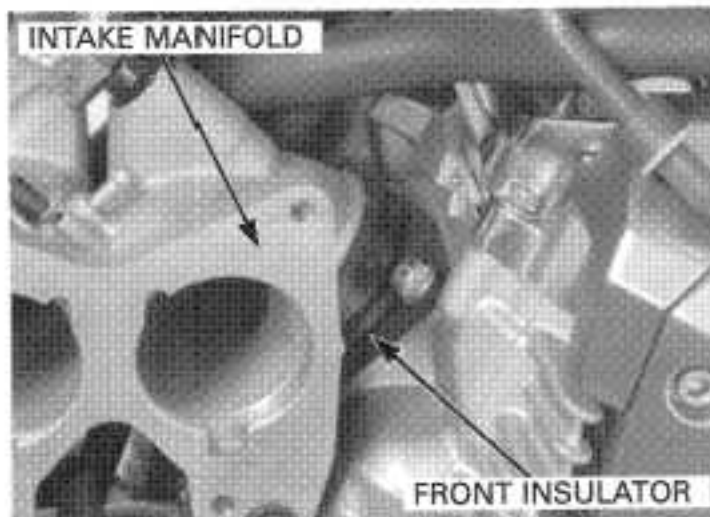

Install the intake manifold/rear insulator to the cylinder head and align the bolt holes.

Install and tighten the rear insulator socket bolts securely.

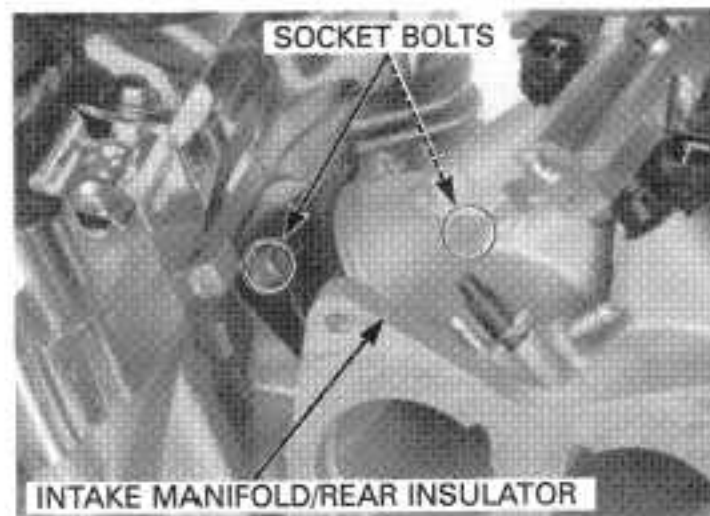

Tighten the insulator band so the insulator band distance is 9 mm (0.4 in).

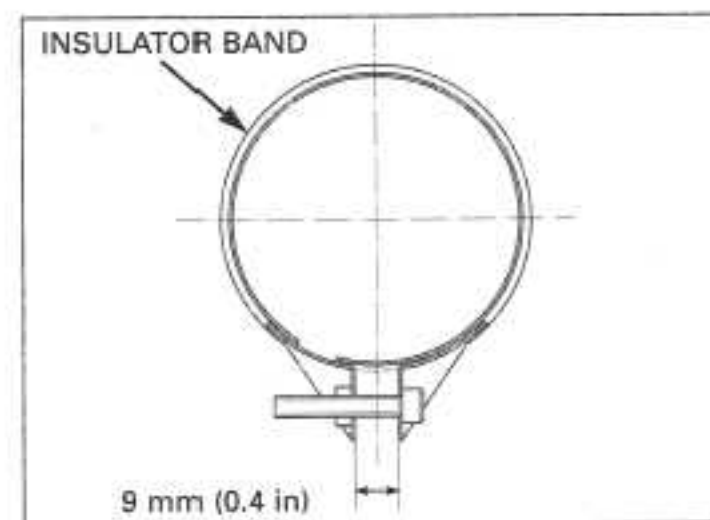
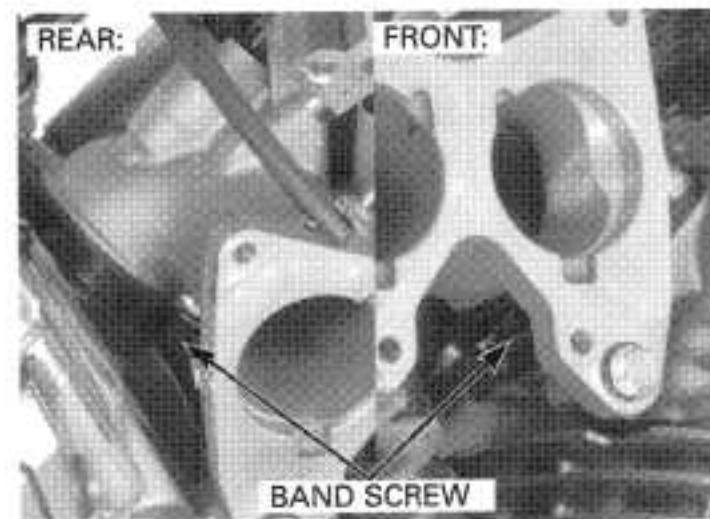

## FUEL SYSTEM (Programmed Fuel Injection)

Install and tighten the bolts securely.

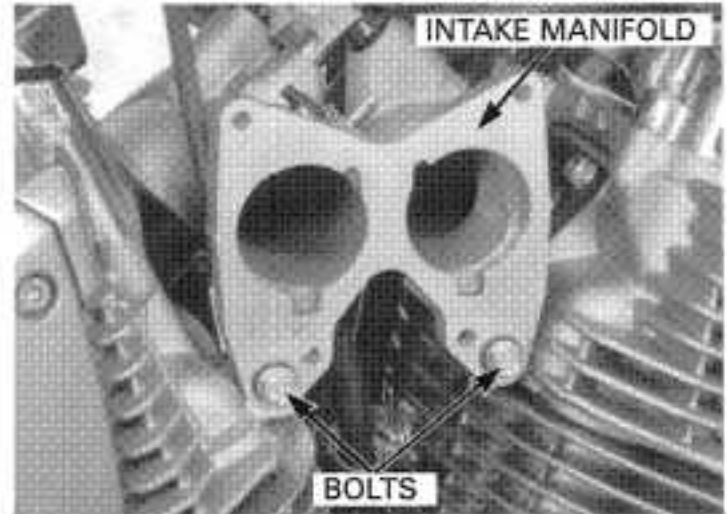

Connect the intake duct control solenoid valve hose to the intake manifold.

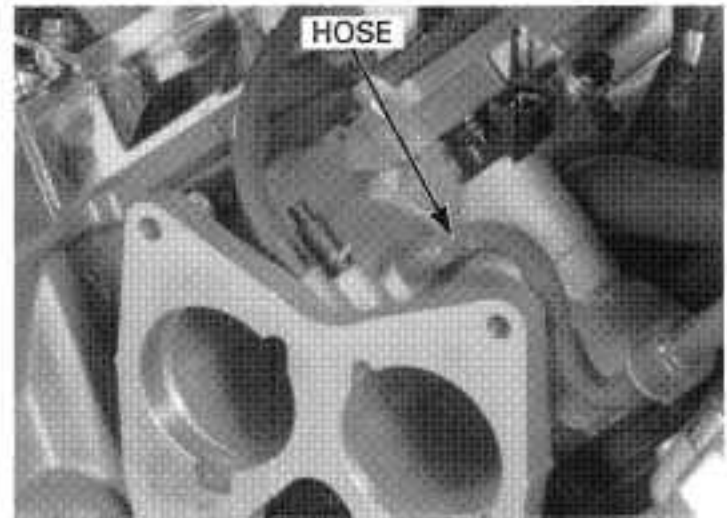

*Install the injector 2P connectors to their original position.*

Connect the 2P brown connector to the front injector.  
Connect the 2P gray connector to the rear injector.

Install the throttle body (see below).

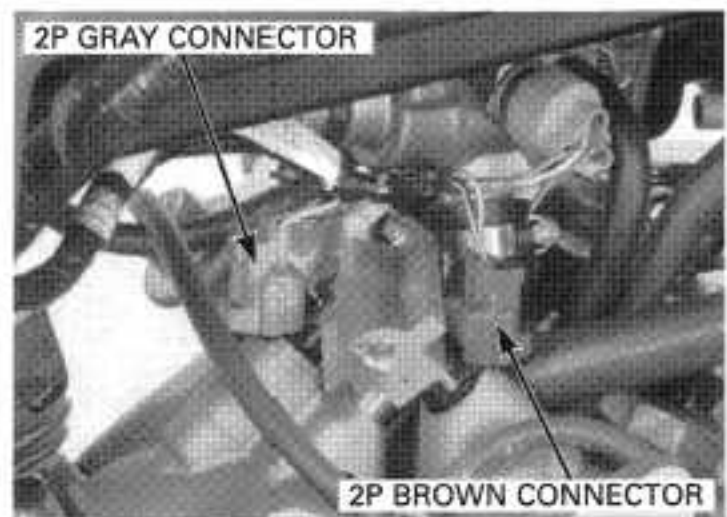

### THROTTLE BODY INSTALLATION

Check that the O-ring is in good condition, replace if necessary.

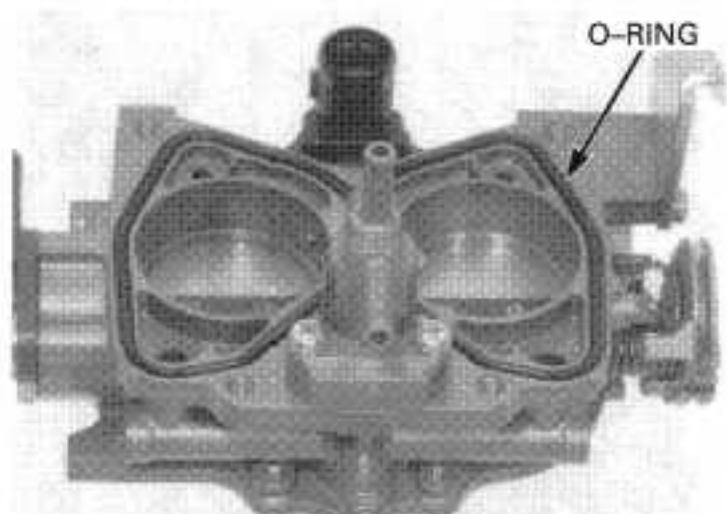

## FUEL SYSTEM (Programmed Fuel Injection)

Connect the water hose and tighten the band screw securely.

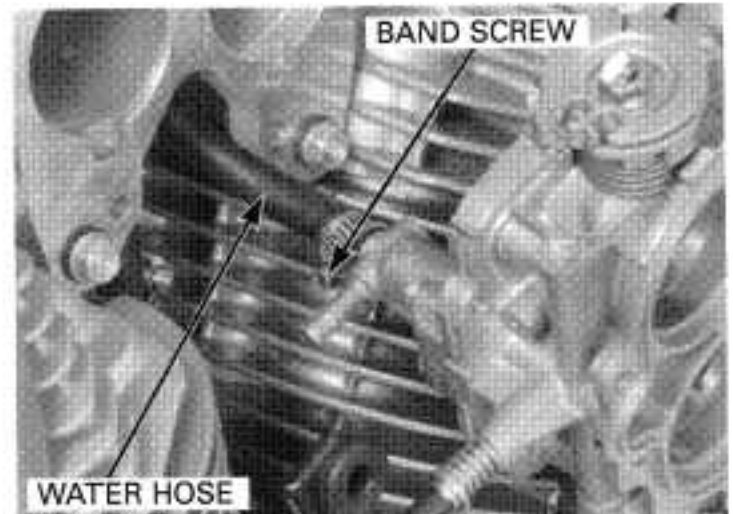

Connect the throttle cables to the throttle drum.

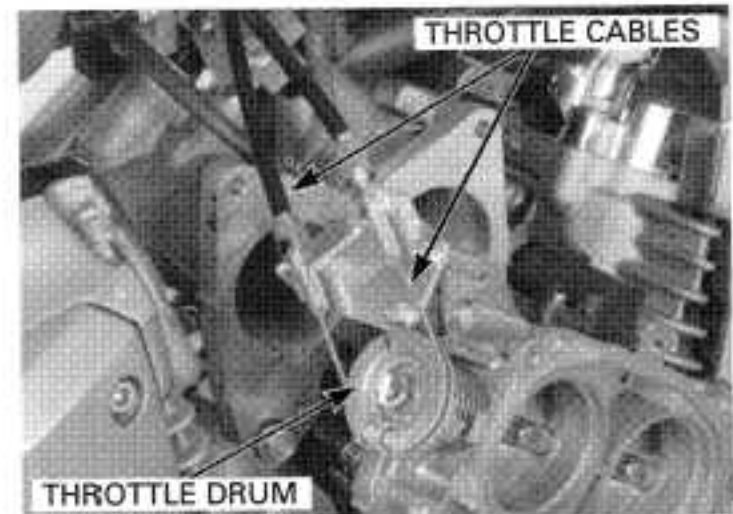

Install the throttle body and clamp.  
Tighten the bolts securely.

Install the sub-harness to the clamp.

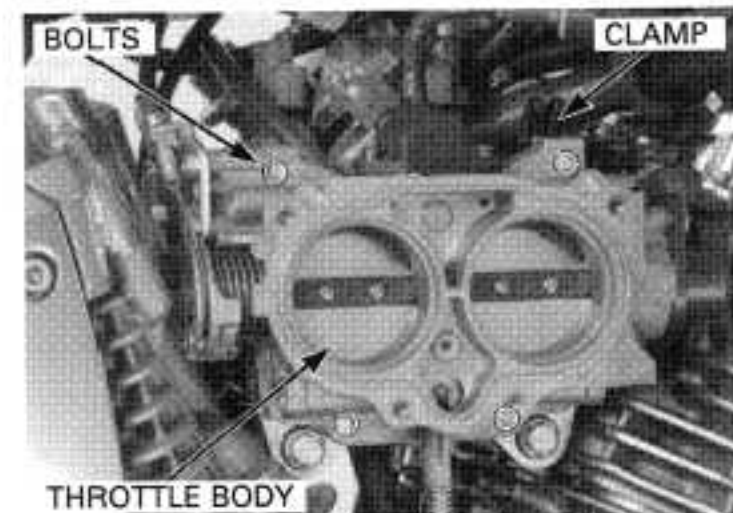

Connect the water hose and tighten the band screw securely.

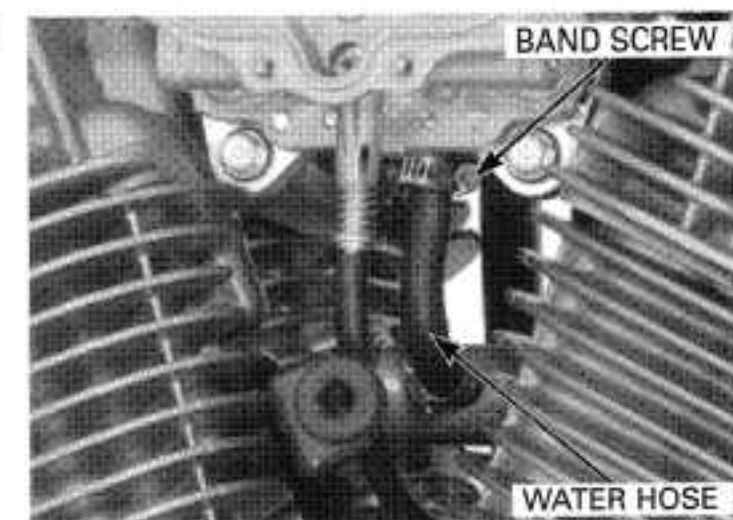

## FUEL SYSTEM (Programmed Fuel Injection)

Connect the TP sensor 3P gray connector and MAP sensor 3P black connector.



Install the throttle stop screw to the guide.

Install the following:

- Air cleaner housing (page 5-57)
- Fuel tank (page 5-56)

Fill the cooling system with the recommended coolant and bleed any air (page 6-5).



## INJECTORS

### INSPECTION

Start the engine and let it idle.  
Confirm the injector operating sounds with a sounding rod or stethoscope.

If the injector does not operate, replace it.

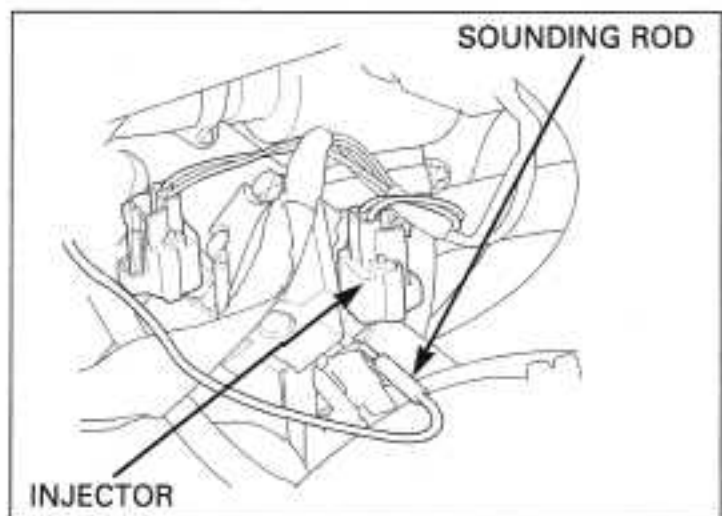

### REMOVAL

Remove the intake manifold (page 5-60).

Disconnect the vacuum hose.  
Remove the bolts and pressure regulator.  
Remove the O-ring.

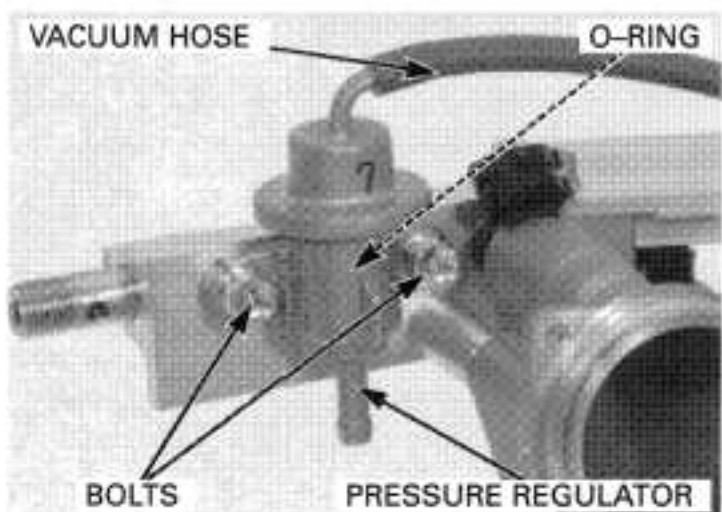



## FUEL SYSTEM (Programmed Fuel Injection)

Remove the bolts, fuel rail A and O-ring.

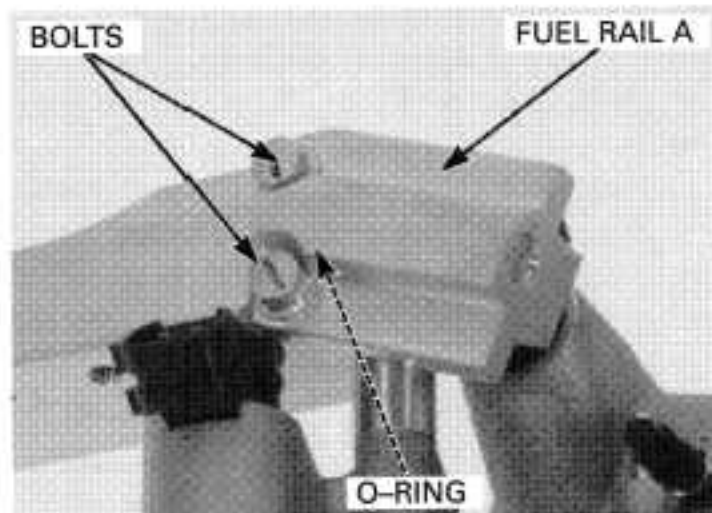

Remove the front injector from the intake manifold.

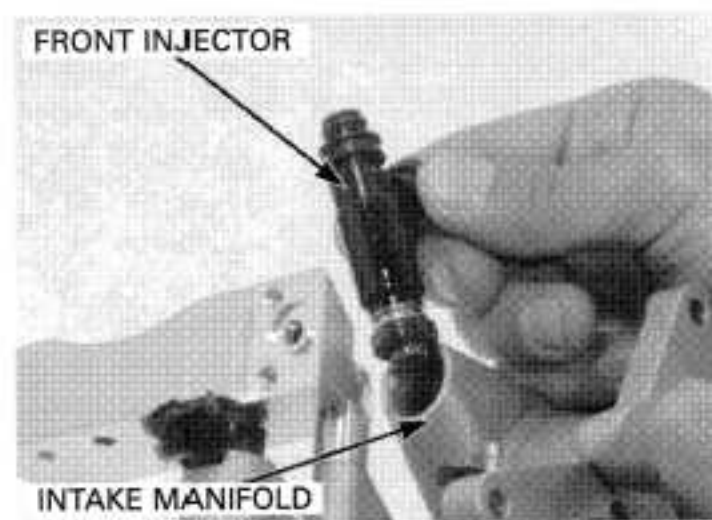

Remove the nuts, fuel rail B and collars.

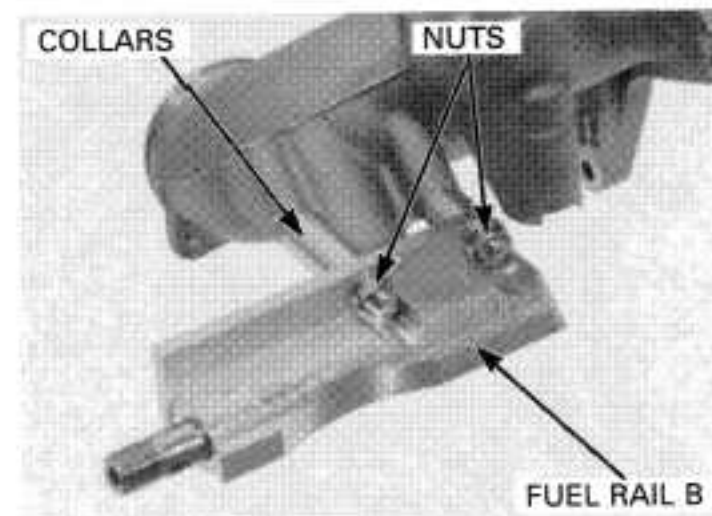

Remove the rear injector from the intake manifold.

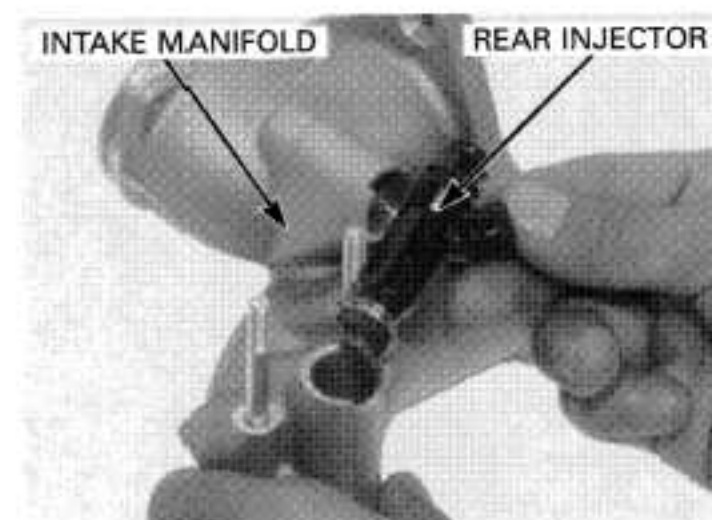



# FUEL SYSTEM (Programmed Fuel Injection)

Remove the seal ring, O-ring and cushion ring from the injector.

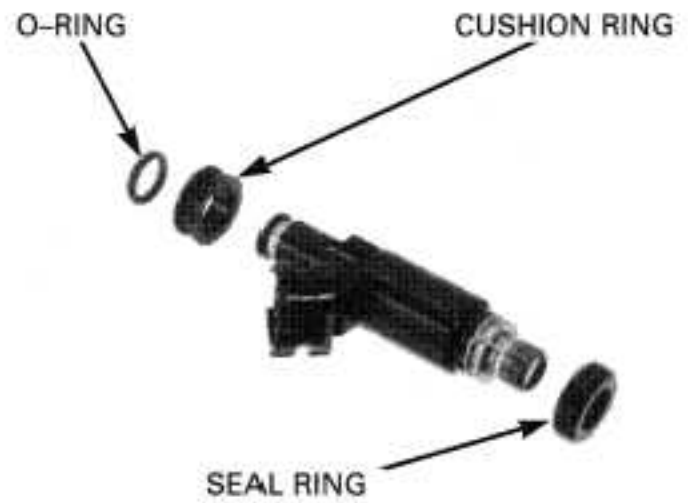

## INSTALLATION

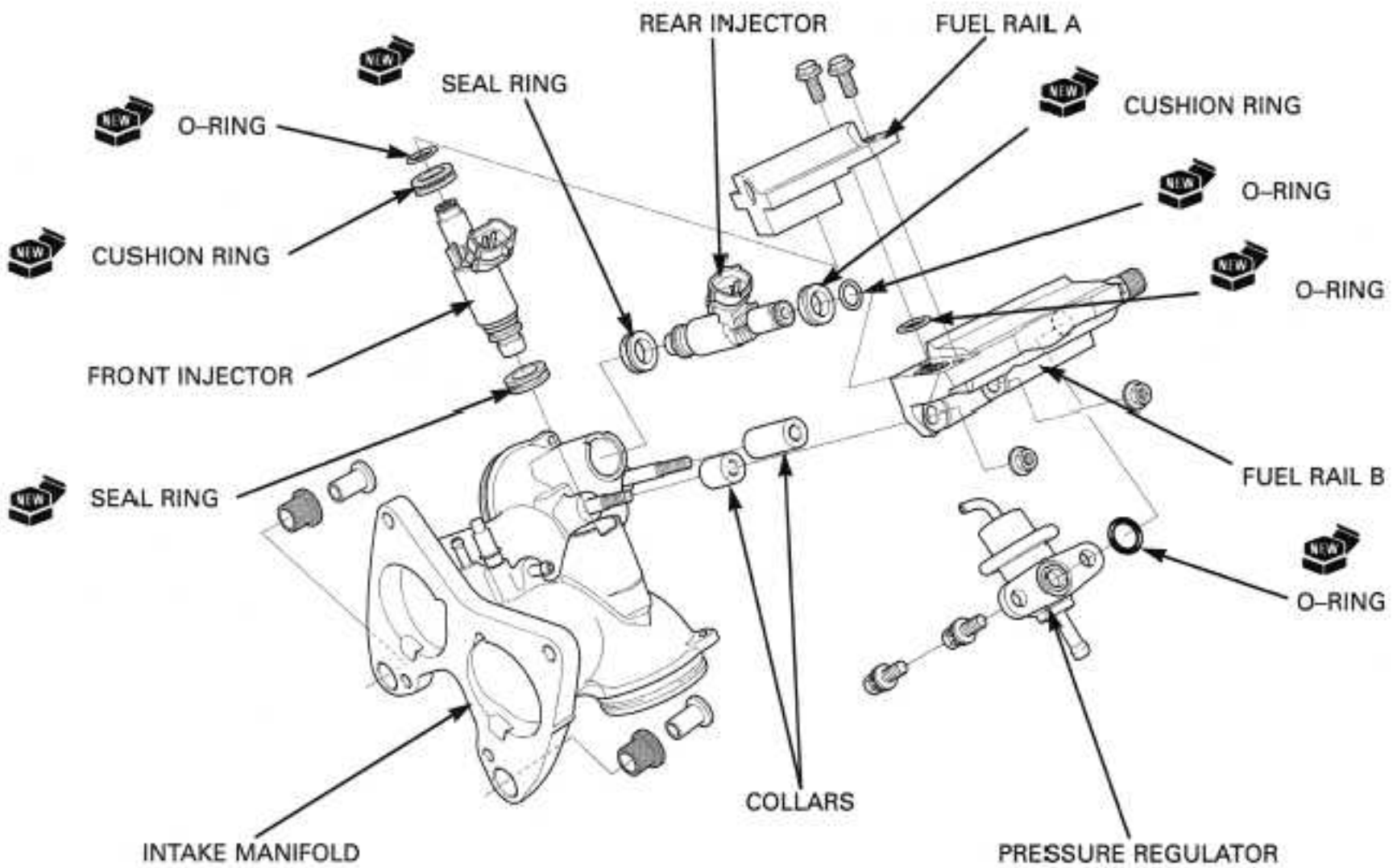

Replace the seal ring, cushion ring and O-ring with new ones as a set.

Apply oil to the new O-ring. Install the new seal ring, cushion ring and O-ring, being careful not to damage the O-ring.

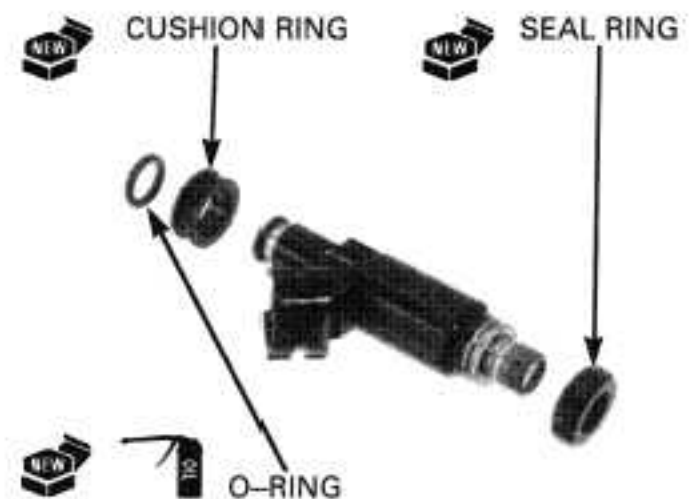

## FUEL SYSTEM (Programmed Fuel Injection)

Install the rear injector to the intake manifold aligning the connector of the injector and groove on the intake manifold.

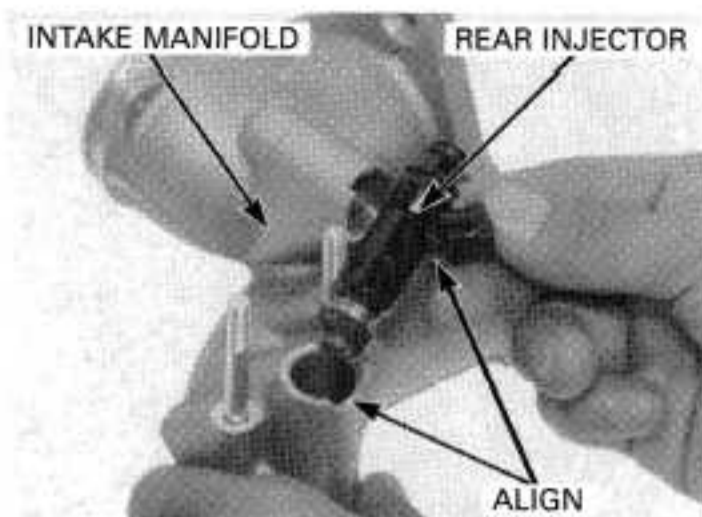

*Be careful not to damage the O-ring.*

Install the collars, fuel rail B and tighten the nuts securely.

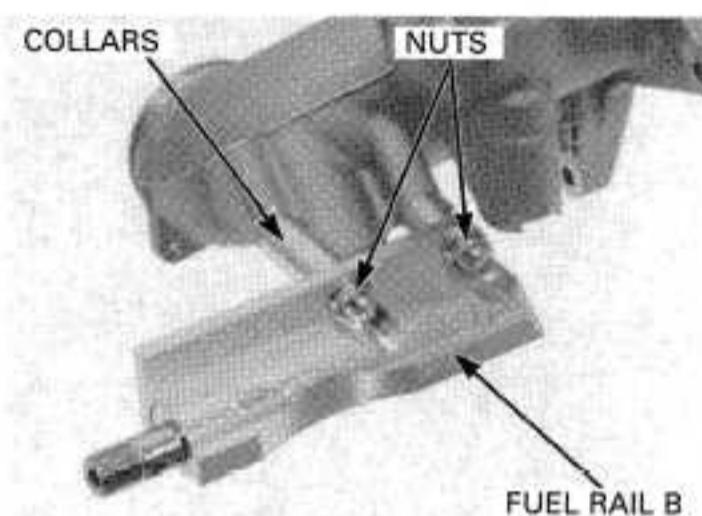

Install the front injector to the intake manifold aligning the connector of the injector and groove on the intake manifold.

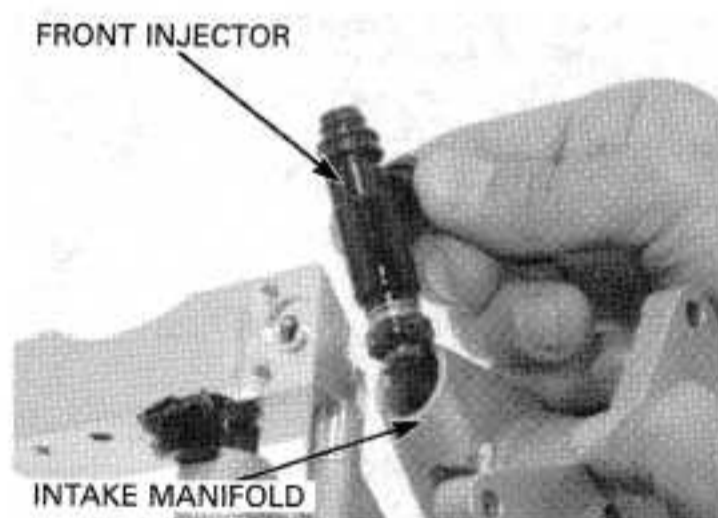

Install a new O-ring to fuel rail B.

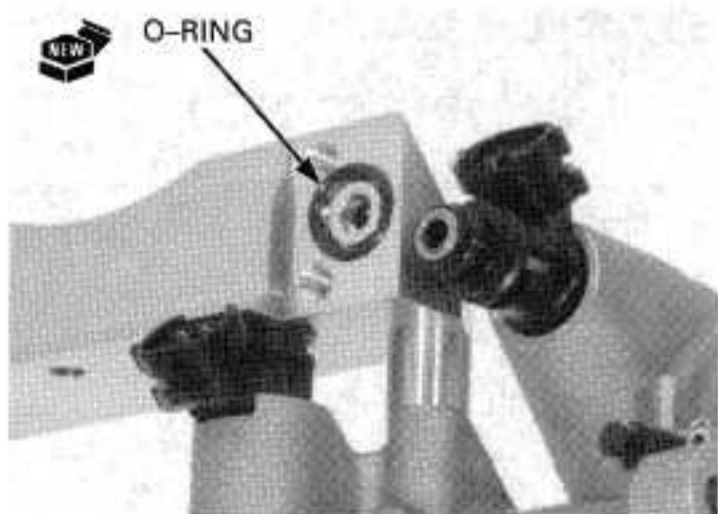

## FUEL SYSTEM (Programmed Fuel Injection)

Be careful not to damage the O-ring.

Install fuel rail A and tighten the bolts securely.

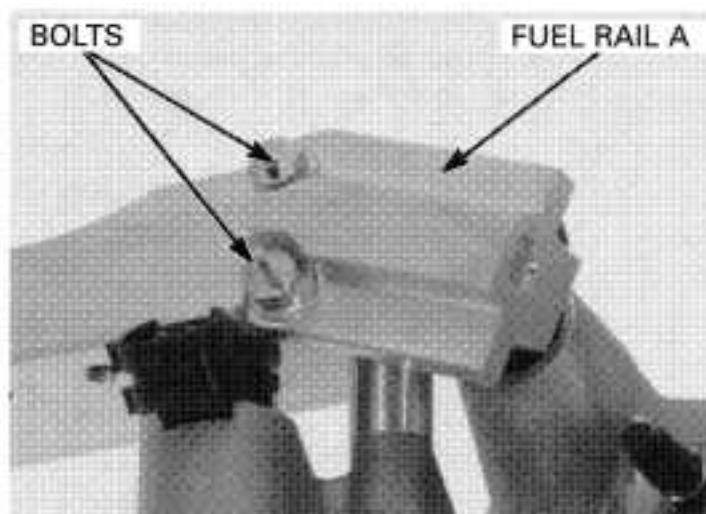

Install a new O-ring to the pressure regulator.

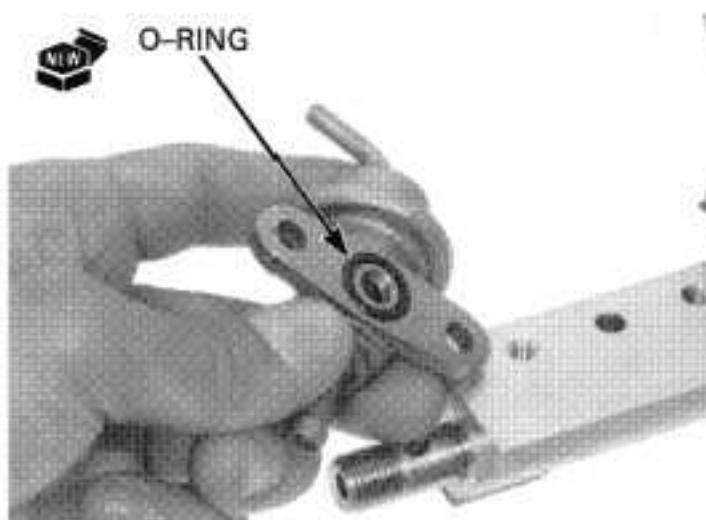

Install the pressure regulator and tighten the bolts securely.  
Connect the vacuum hose.

Install the intake manifold (page 5-62).

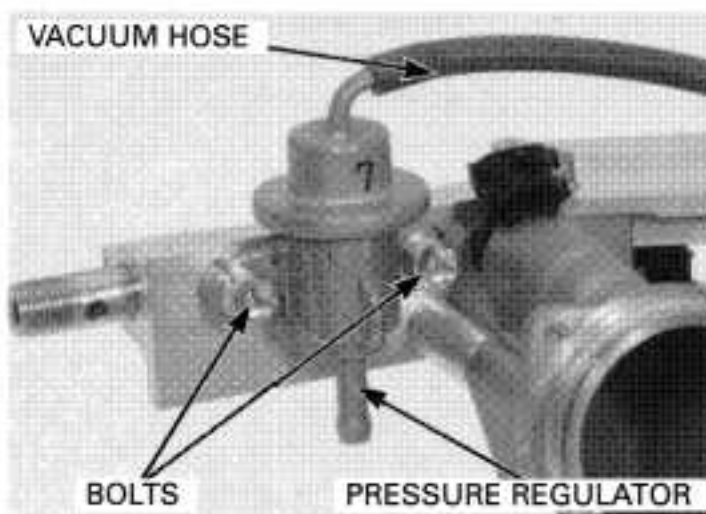

## STARTER VALVE

### DISASSEMBLY

Remove the throttle body (page 5-58).

Remove the screws and starter valve assembly from the throttle body.

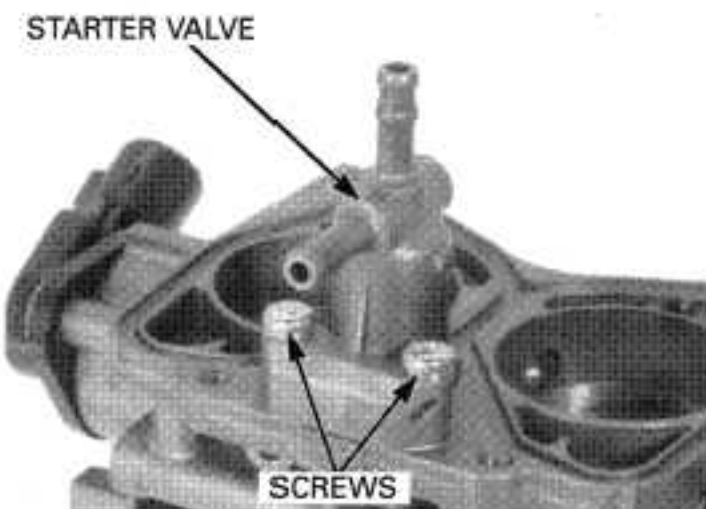

Remove the starter valve assembly from the throttle body.

*Do not apply commercially available carburetor cleaners to the inside of the throttle bore, which is coated with molybdenum.*

Clean the starter valve bypass using compressed air.

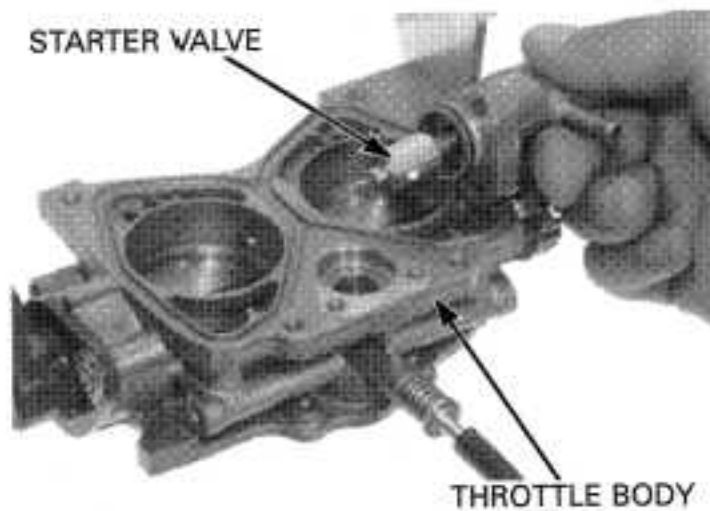

Remove the O-ring from the starter valve assembly.

Check the starter valve for wear or damage.

Replace the starter valve assembly if necessary.

### ASSEMBLY

Install a new O-ring to the starter valve groove.

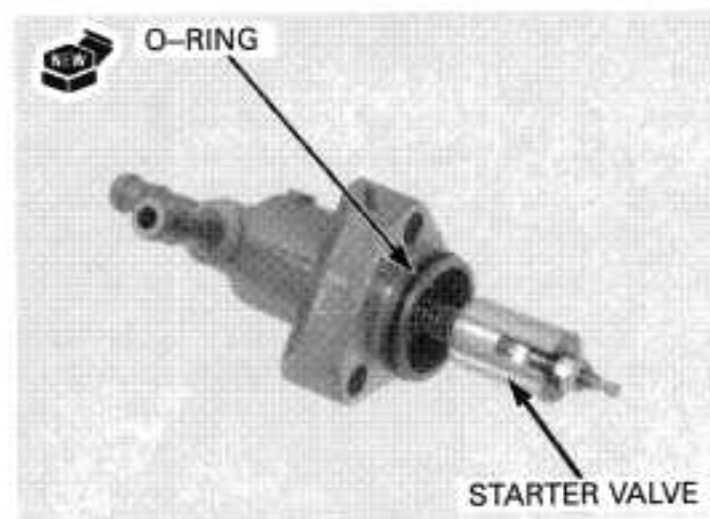

Install the starter valve assembly to the throttle body aligning the groove on the starter valve with the end of the throttle stop screw.

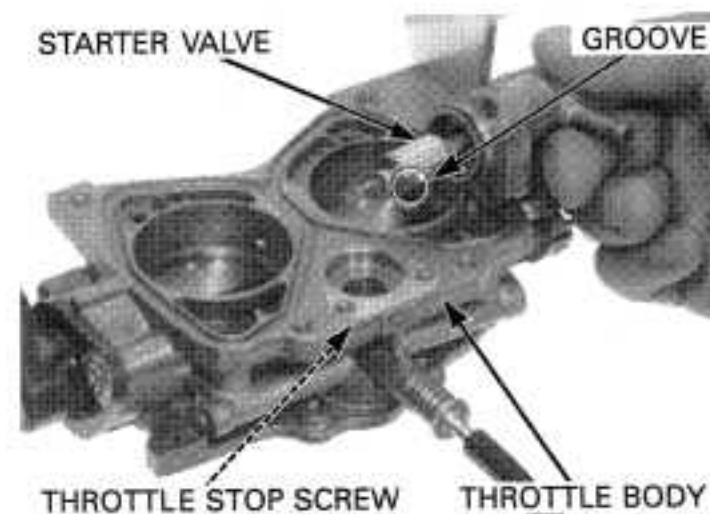

Install and tighten the screws to the specified torque.

**TORQUE: 3.4 N·m (0.35 kgf·m, 2.5 lbf·ft)**

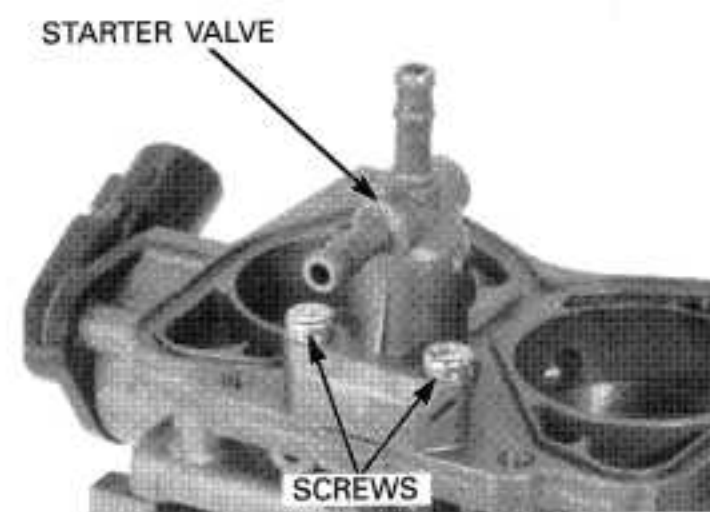



### AIR SCREW SYNCHRONIZATION

**NOTE:**

Synchronize the air screw with the engine at the normal operating temperature and with the transmission in neutral.

Open and support the rear end of the fuel tank (page 3-4).  
Remove the air cleaner housing (page 5-57).

Disconnect the intake duct control solenoid valve hose from the intake manifold.  
Remove the vacuum joint plug from the intake manifold.  
Connect the vacuum gauge hoses to the hose joints.

**TOOL:**

**Vacuum gauge set**                      **07LMJ-001000A**

Connect the tachometer.  
Start the engine and let it idle until the radiator fan starts.

1. Check the difference in vacuum between each cylinder.
  - The front cylinder vacuum pressure is higher than the rear cylinder vacuum pressure:  
Adjust the front cylinder vacuum pressure with the rear cylinder vacuum pressure by turning in the front cylinder air screw.
  - The rear cylinder vacuum pressure is higher than the front cylinder vacuum pressure:  
Adjust the front cylinder vacuum pressure with the rear cylinder vacuum pressure by turning out the front cylinder air screw.

**TOOL:**

**Pilot screw wrench**                      **07908-4730002**

2. If the front cylinder air screw is 1•1/2 turns in/out or more, adjust the rear cylinder air screw.
  - 1•1/2 turns in or more: Turn out the rear cylinder air screw 1/2 turn.
  - 1•1/2 turns out or more: Turn in the rear cylinder air screw 1/2 turn.Then, repeat step 1.
3. Stop the engine.  
Disconnect the vacuum gauge hoses from the hose joints.  
Connect the intake duct control solenoid valve hose to the intake manifold.  
Install the vacuum joint plug to the intake manifold.  
  
Install the air cleaner housing (page 5-57).  
Close the fuel tank.  
Start the engine and let it idle.
4. Turn the throttle stop screw as required to obtain the specified idle speed.

**IDLE SPEED: 800 ± 100 rpm**

Stop the engine.

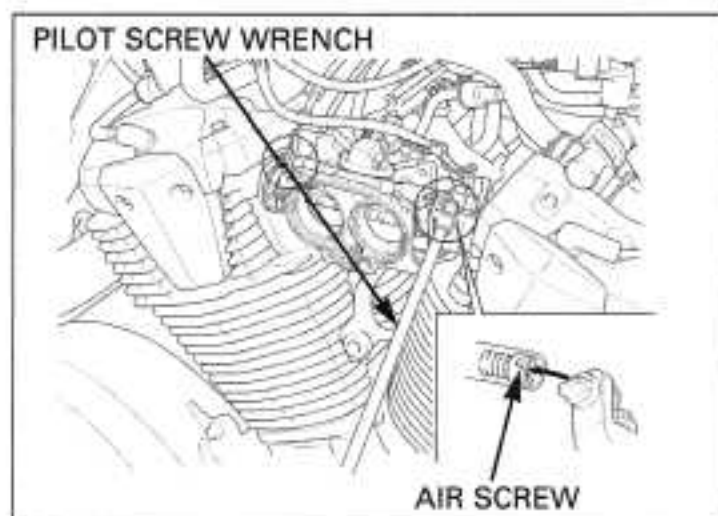
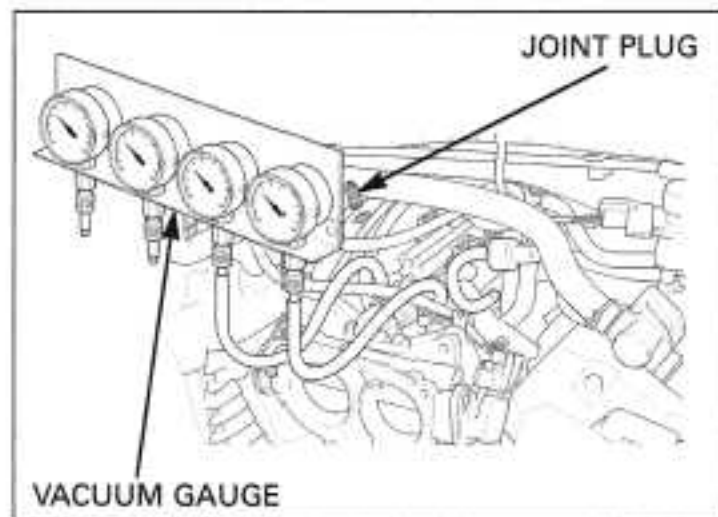
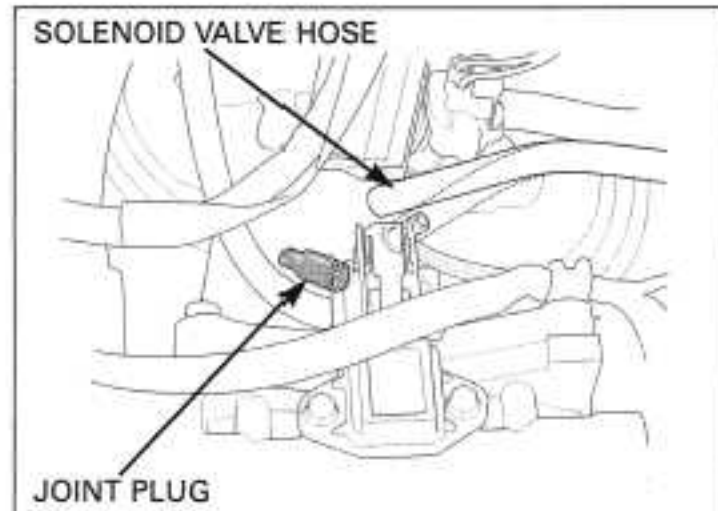



## BARO/MAP SENSOR

### OUTPUT VOLTAGE INSPECTION

Connect the test harness to the ECM (page 5-8).

Measure the voltage at the test harness terminals (page 5-9).

#### CONNECTION:

**BARO sensor:** B1 (+) - B8 (-)

**MAP sensor:** B1 (+) - B7 (-)

**STANDARD:** 2.7 - 3.1 V

The BARO and MAP sensor output voltage (above) is measured under the standard atmosphere (1 atm = 1,030 hPa).

The BARO and MAP sensor output voltage is affected by the distance above sea level, because the output voltage is changed by atmosphere.

Check the sea level measurement and be sure the measured voltage falls within the specified value.

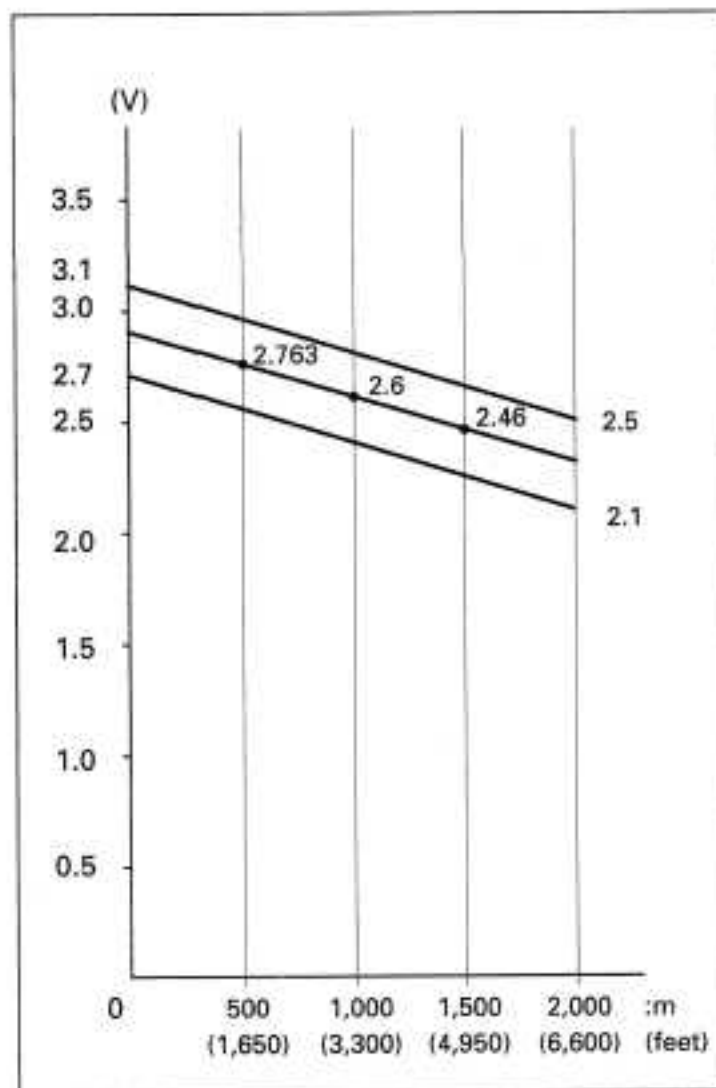

### BARO SENSOR REMOVAL/INSTALLATION

Remove the seat (page 2-2).

Remove the tool box cover (page 16-7).

Remove the screw and disconnect the BARO sensor 3P connector.

Remove the BARO sensor.

Installation is in the reverse order of removal.

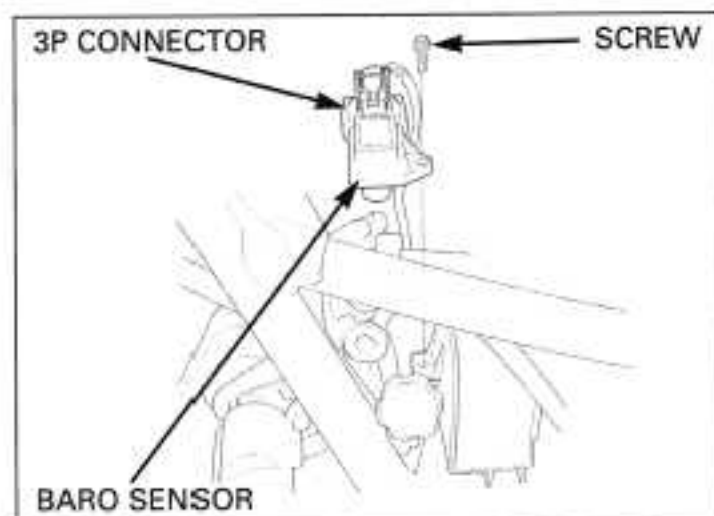

### MAP SENSOR REMOVAL/INSTALLATION

Remove the air cleaner housing (page 5-57).

Remove the screws, MAP sensor and O-ring.

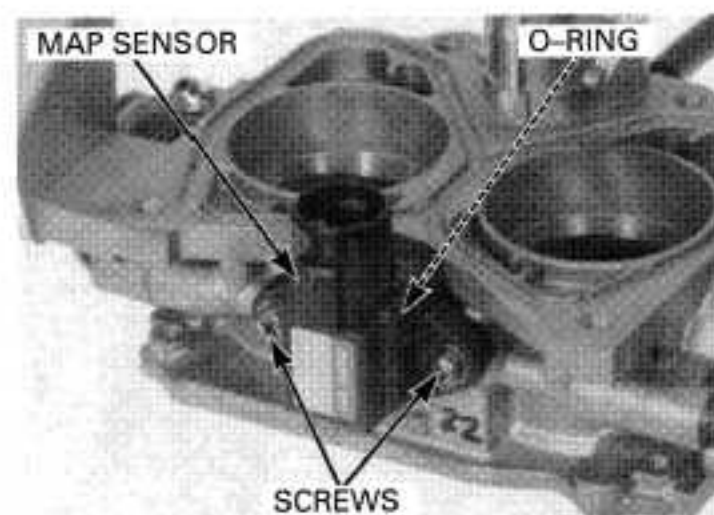

## FUEL SYSTEM (Programmed Fuel Injection)

*Always replace an O-ring with a new one.*

Installation is in the reverse order of removal.  
Install and tighten the screws to the specified torque.

**TORQUE: 2.1 N·m (0.21 kgf·m, 1.5 lbf·ft)**

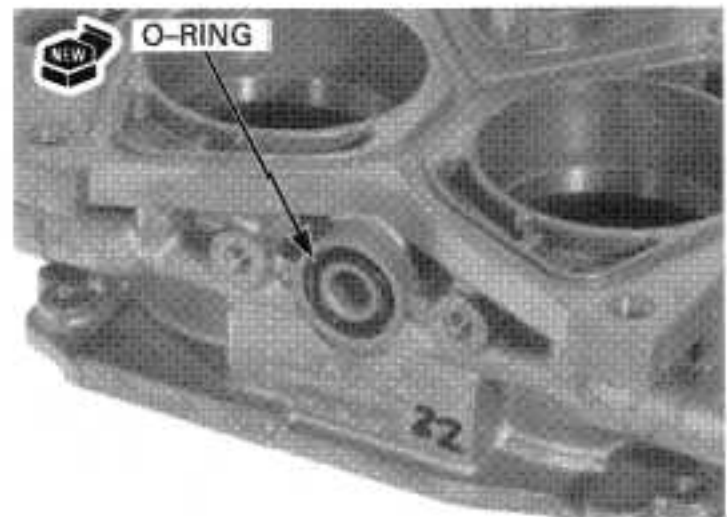

## IAT SENSOR

### REMOVAL/INSTALLATION

Remove the air cleaner housing (page 5-57).  
Remove the screws and IAT sensor from the air cleaner housing.  
Installation is in the reverse order of removal.

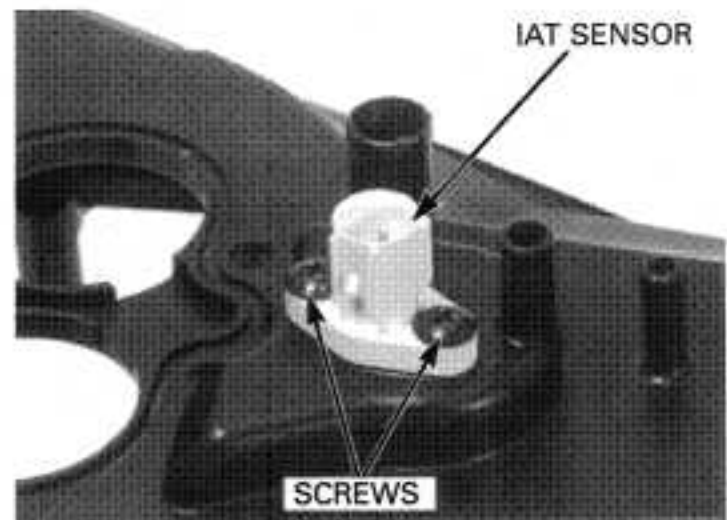

## ECT SENSOR

### REMOVAL/INSTALLATION

*Replace the ECT sensor while the engine is cold.*

Drain the coolant from the system (page 6-5).  
Remove the air cleaner housing (page 5-57).  
Disconnect the ECT sensor 3P connector from the sensor.

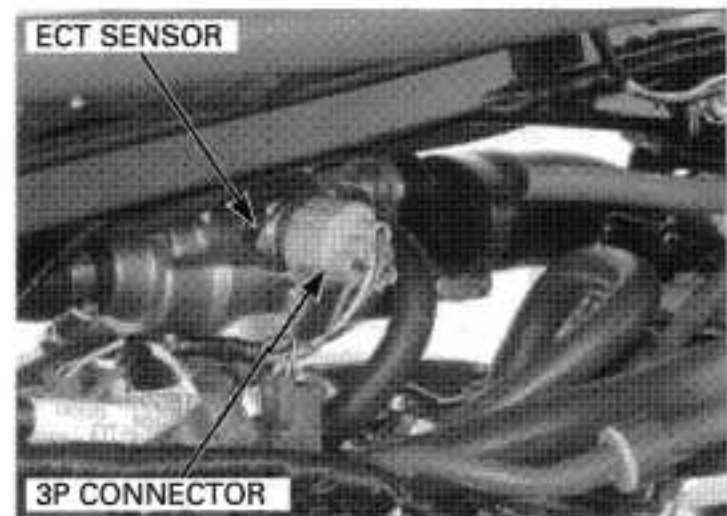

Remove the ECT sensor and sealing washer.

*Always replace a sealing washer with a new one.*

Install the new sealing washer and ECT sensor.  
Tighten the ECT sensor to the specified torque.

**TORQUE: 18 N·m (1.8 kgf·m, 13 lbf·ft)**

Connect the ECT sensor 3P connector.

Fill the cooling system with the recommended coolant (page 6-5).

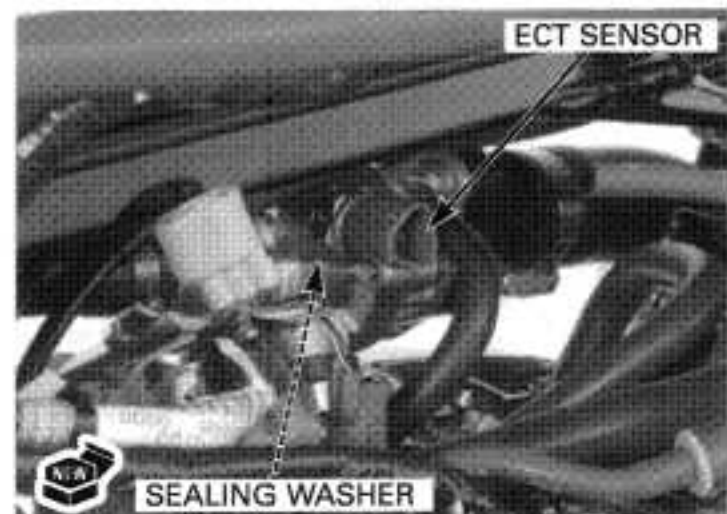

## CAM PULSE GENERATOR

### REMOVAL/INSTALLATION

Open and support the rear end of the fuel tank (page 3-4).

Disconnect the cam pulse generator 2P black connector.

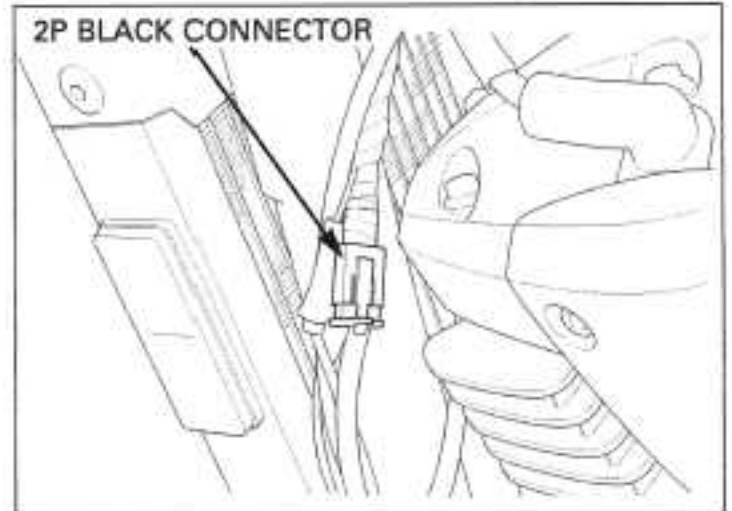

Remove the bolt and cam pulse generator.

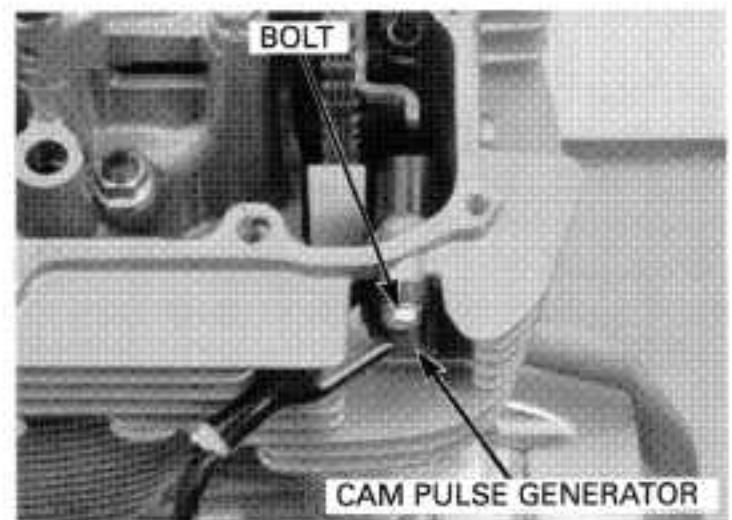

Remove the O-ring from the cam pulse generator groove.

*Always replace an O-ring with a new one.*

Installation is in the reverse order of removal.

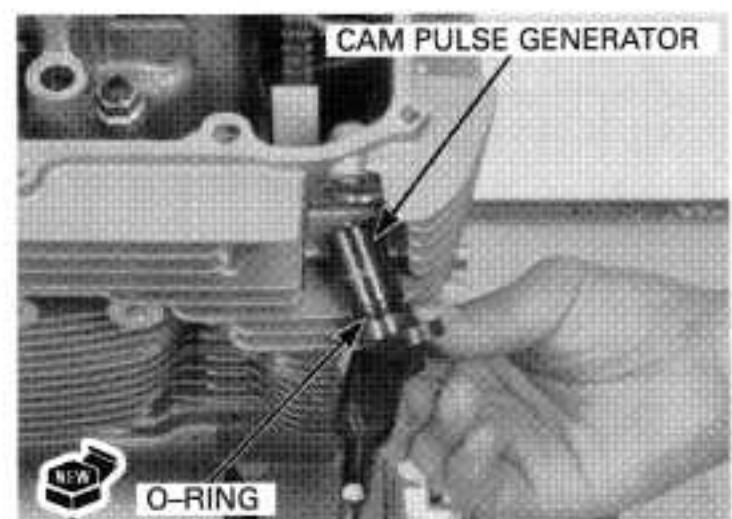

## TP SENSOR

### INSPECTION

Remove the seat (page 2-2).

Disconnect the ECM 22P black and 22P gray connectors.

Check the connector for loose or corroded terminals. Connect the ECU test harness between the ECM and main wire harness.

#### TOOL:

ECU test harness

07YMZ-0010100  
(two required)

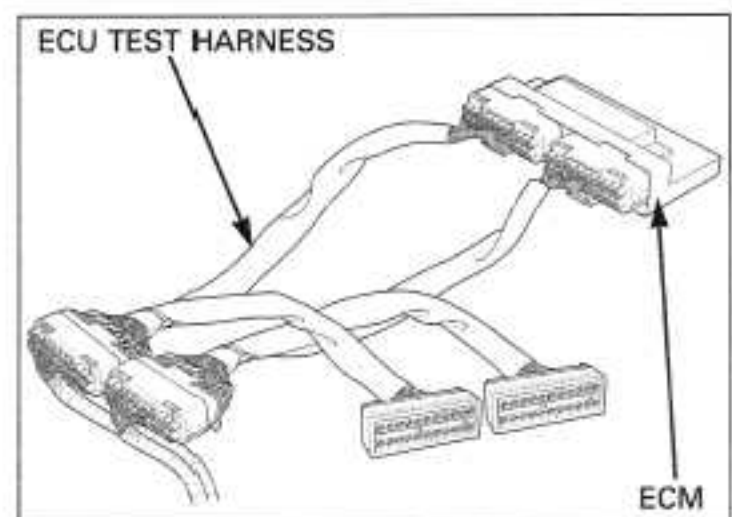

## FUEL SYSTEM (Programmed Fuel Injection)

### 1. INPUT VOLTAGE INSPECTION

Turn the ignition switch to "ON", then measure and record the input voltage at the test harness terminals using a digital multimeter.

#### CONNECTION:

**B2 (+) – A22 (-)**

**Standard: 4.5 – 5.5 V**

If the measurement is out of specification, check the following:

- Loose connection of the ECM multi-connector
- Open circuit in the wire harness

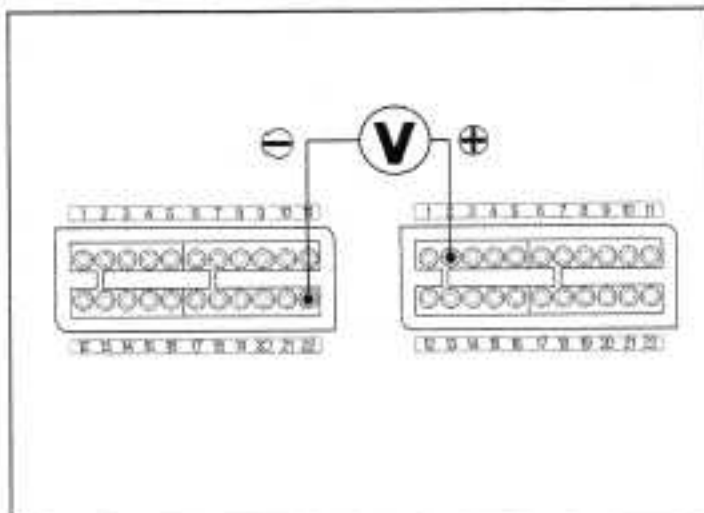

### 2. OUTPUT VOLTAGE INSPECTION WITH THROTTLE FULLY OPEN

Turn the ignition switch to "ON" and measure and record the output voltage at the test harness terminals.

#### CONNECTION:

**B9 (+) – A22 (-)**

#### MEASURING CONDITION:

**Throttle fully open**

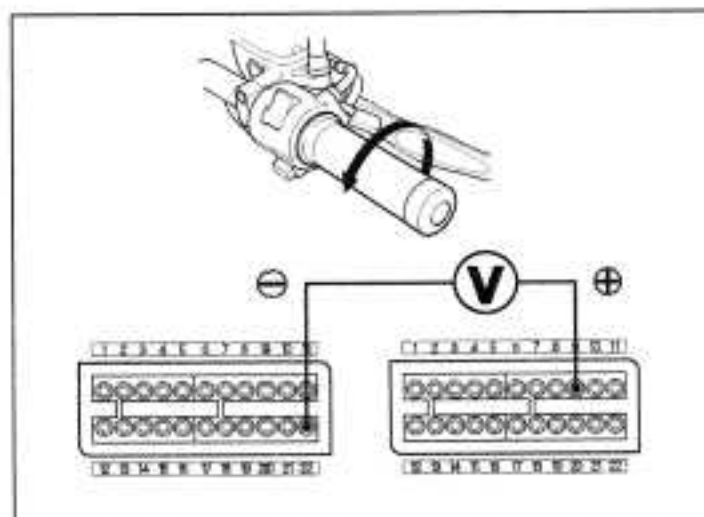

### 3. OUTPUT VOLTAGE INSPECTION WITH THROTTLE FULLY CLOSED

Turn the ignition switch to "ON", then measure and record the output voltage with the throttle fully closed.

#### CONNECTION:

**B9 (+) – A22 (-)**

#### MEASURING CONDITION:

**Throttle fully closed**

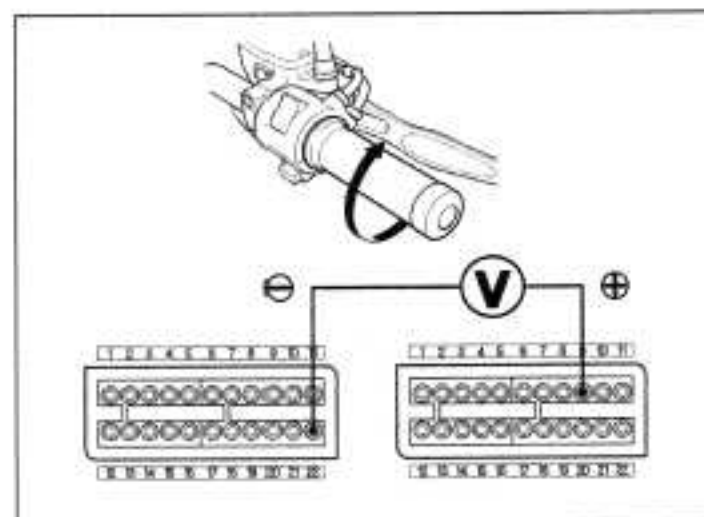

### 4. CALCULATE RESULT COMPARISON

Compare the measurement to the result of the following calculation.

With the throttle fully open:

**Measured input voltage x 0.824 =  $V_o$**

The sensor is normal if the measurement output voltage measured in step 2 is within 10% of  $V_o$ .

With the throttle fully closed:

**Measured input voltage x 0.1 =  $V_c$**

The sensor is normal if the throttle closed output voltage measured in step 3 is within 10% of  $V_c$ .

Using an analog meter, check that the needle of the voltmeter swings slowly when the throttle is opened gradually.



**CONTINUITY INSPECTION**

Open and support the rear end of the fuel tank (page 3-4).

Disconnect the ECM 22P gray connector and the TP sensor 3P connector.  
Check for continuity between the ECM and TP sensor.

If there is no continuity, check for an open or short circuit in the wire harness.

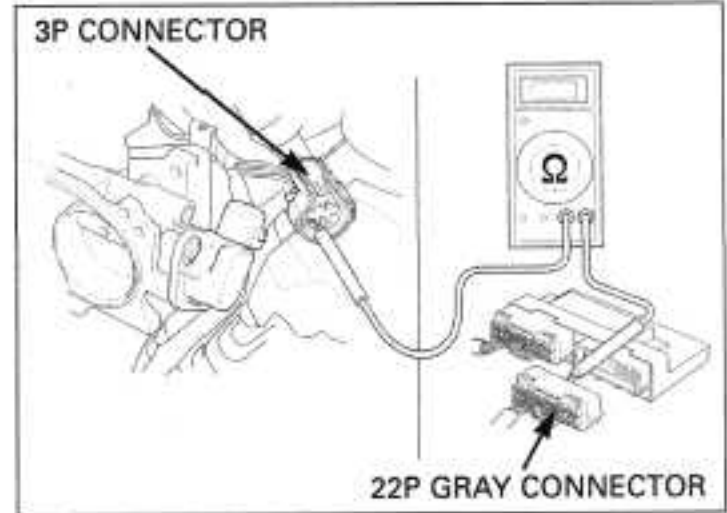

**BANK ANGLE SENSOR**

**INSPECTION**

Support the motorcycle on a level surface.  
Remove the seat (page 2-2).

Turn the ignition switch to "ON" and measure the voltage between the following terminals of the bank angle sensor 3P green connector with the connector connected.

TERMINAL	STANDARD
White/black (+) - Green (-)	Battery voltage
Red/white (+) - Green (-)	0 - 1 V

*Do not disconnect the bank angle sensor connector during inspection.*

Turn the ignition switch to "OFF".

Disconnect the bank angle sensor 3P green connector.

Remove the battery case (page 16-7).

Remove the screws and bank angle sensor.

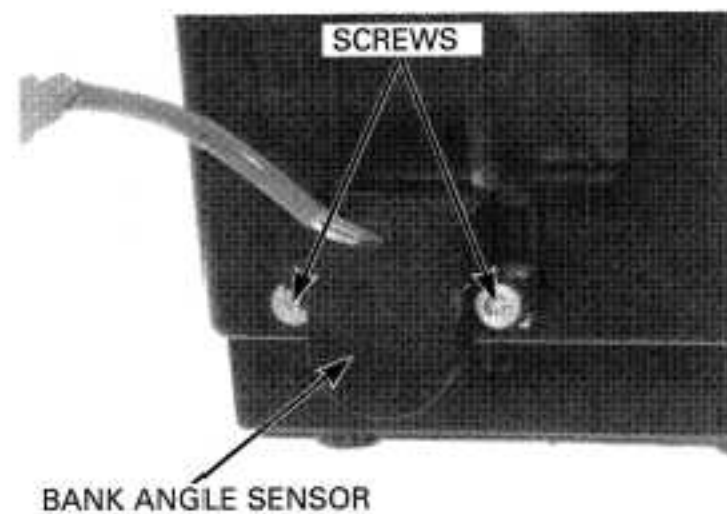
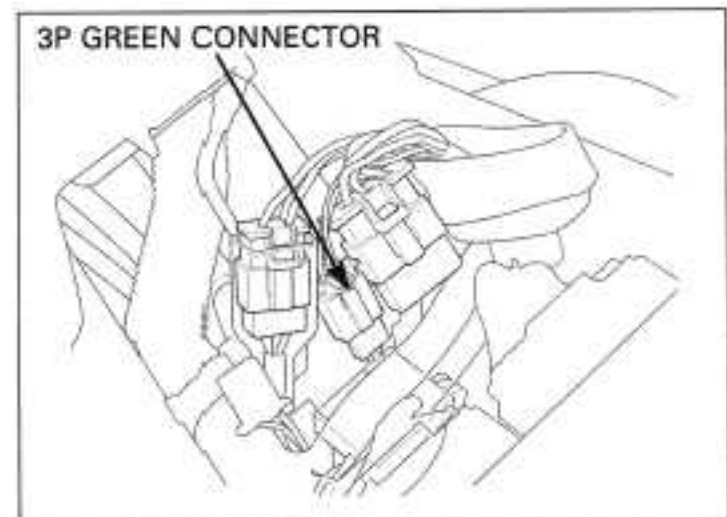

Place the bank angle sensor horizontal as shown, and turn the ignition switch to "ON".

The bank angle sensor is normal if the engine stop relay clicks and power supply is closed.

Incline the bank angle sensor approximately 42.5 degrees to the left or right with the ignition switch turned to "ON".

The bank angle sensor is normal if the engine stop relay clicks and power supply is open.

If you repeat this test, first turn the ignition switch to "OFF", then to "ON".

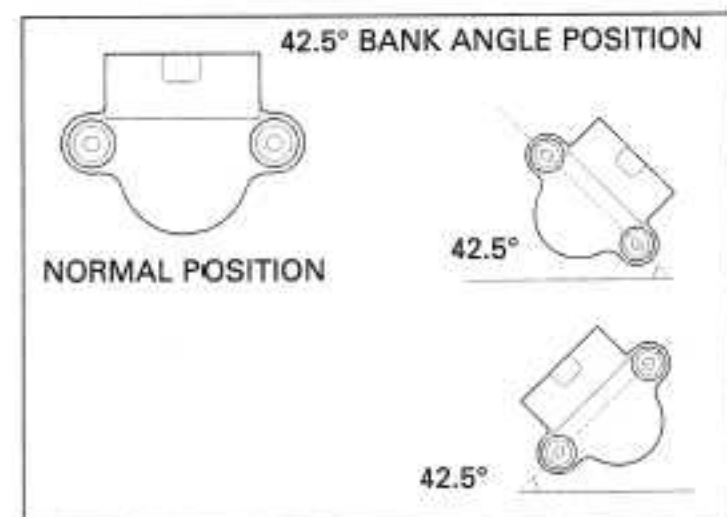



## FUEL SYSTEM (Programmed Fuel Injection)

### REMOVAL/INSTALLATION

Disconnect the bank angle sensor 3P green connector.

Remove the battery case (page 16-7).

Remove the screws and bank angle sensor.

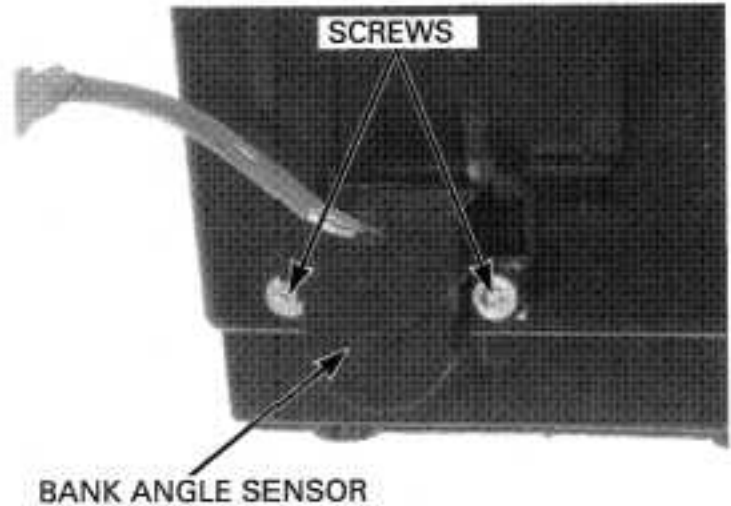

*Install the bank angle sensor with its "UP" mark facing up and towards the battery case.*

Installation is in the reverse order of removal.

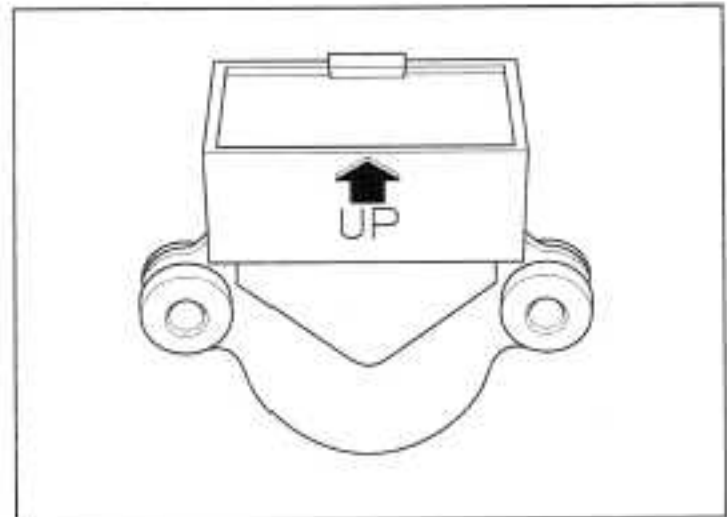

## ENGINE STOP RELAY

### INSPECTION

Disconnect the engine stop relay 4P connector, remove the engine stop relay.

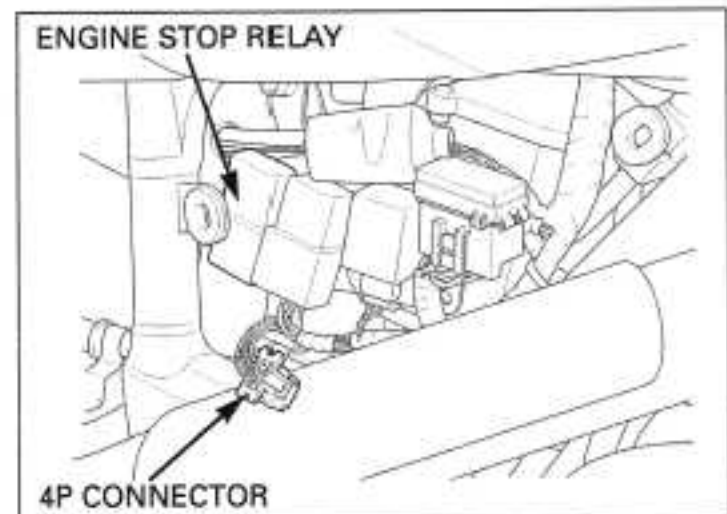

Connect the ohmmeter to the engine stop relay connector terminals.

**CONNECTION: Red/white - Black/white**

Connect the 12-V battery to the following engine stop relay connector terminals.

**CONNECTION: Red/orange - Black**

There should be continuity only when the 12-V battery is connected.

If there is no continuity when the 12-V battery is connected, replace the engine stop relay.

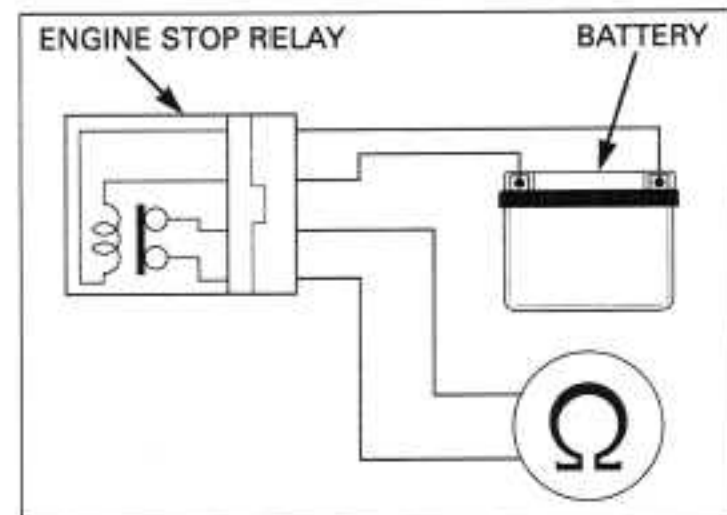

## ECM (Engine Control Module)

### REMOVAL/INSTALLATION

Remove the seat (page 2-2).

Disconnect the ECM 22P black and 22P gray connectors.

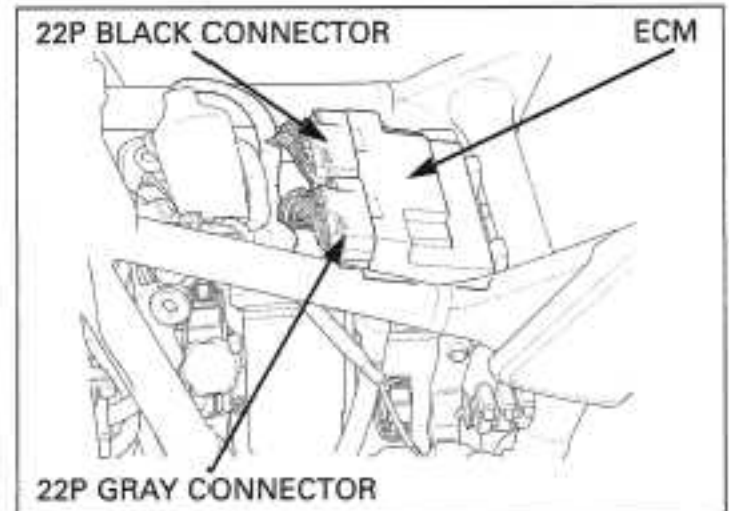

### POWER/GROUND LINE INSPECTION

Connect the test harness between the main wire harness and ECM (page 5-8).

#### TOOL:

ECU test harness

07YMZ-0010100  
(two required)

#### GROUND LINE

Check for continuity between the ECM test harness connector A10 terminal and ground, between the A11 terminal and ground, between the A21 terminal and ground, and between the A22 terminal and ground.

There should be continuity at all times.

If there is no continuity, check for an open circuit in the Green/pink wire and Green wire.

#### POWER INPUT LINE

Turn the ignition switch to "ON" and the engine stop switch to "O".

Measure the voltage between the ECM test harness connector B2 terminal (+) and ground.

There should be battery voltage.

If there is no voltage, check for an open circuit in the Black/white wire between the ECM and bank angle sensor/relay.

If the wire is OK, check the bank angle sensor/relay (page 5-77).

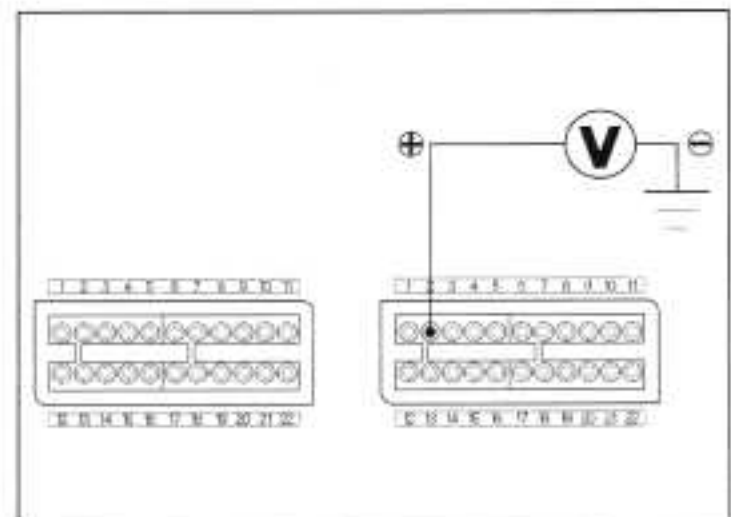
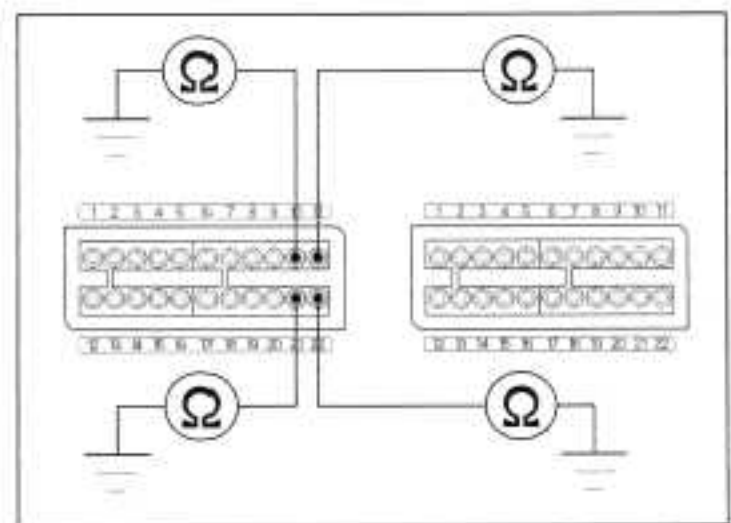

## INTAKE DUCT CONTROL SOLENOID VALVE

### REMOVAL/INSTALLATION

Remove the fuel tank (page 5-56).

Disconnect the intake duct control solenoid valve 2P connector.

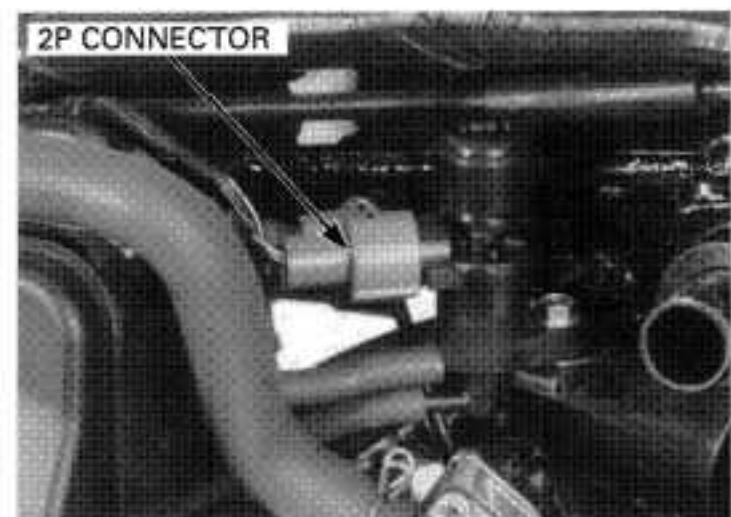

## FUEL SYSTEM (Programmed Fuel Injection)

Disconnect the vacuum hoses from the intake duct control solenoid valve.

Remove the bolt and intake duct control solenoid valve.

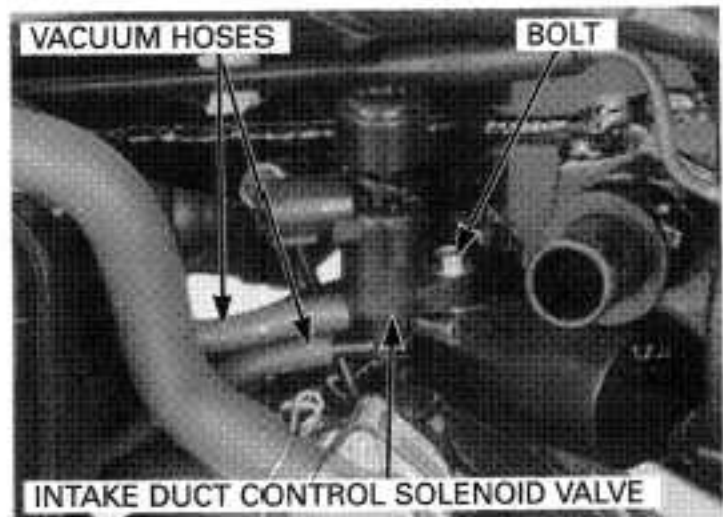

Disconnect the vacuum hose and remove the vacuum chamber.

Check the vacuum chamber for scratches or damage, and replace it if necessary.

Installation is in the reverse order of removal.

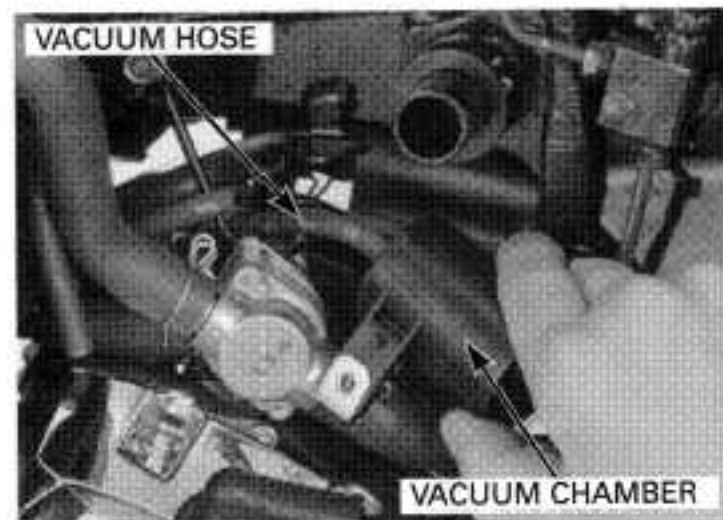

### INSPECTION

Remove the intake duct control solenoid valve.

Check that the air should not flow from (A) to (B), only when the 12-V battery is connected to the intake duct control solenoid valve terminals.

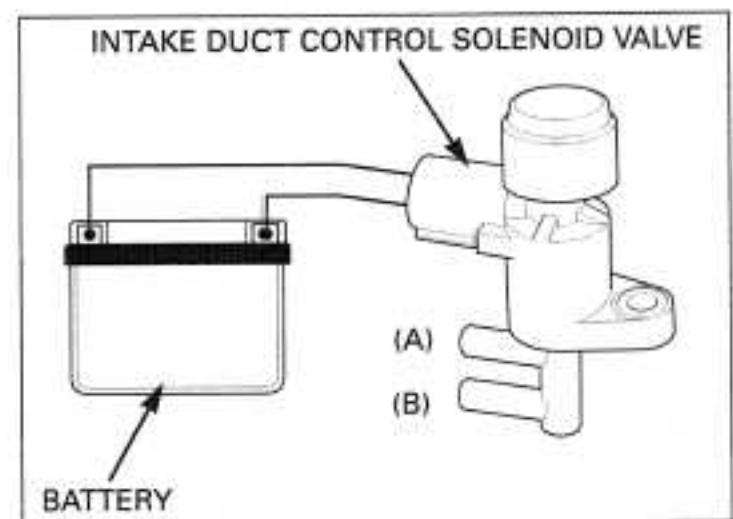

Check the resistance between the terminals of the intake duct control solenoid valve.

**STANDARD: 28 - 32  $\Omega$  (20 °C/68°F)**

If the resistance is out of specification, replace the intake duct control solenoid valve.

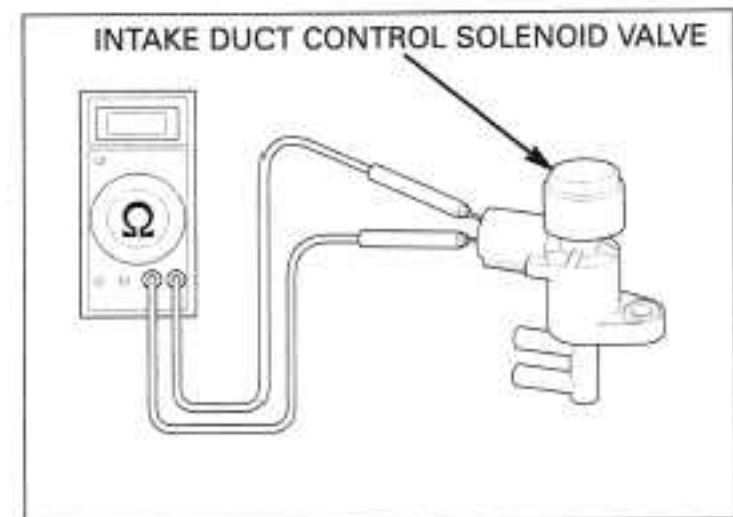

### ONE-WAY VALVE

Disconnect the vacuum hoses and remove the one-way valve.

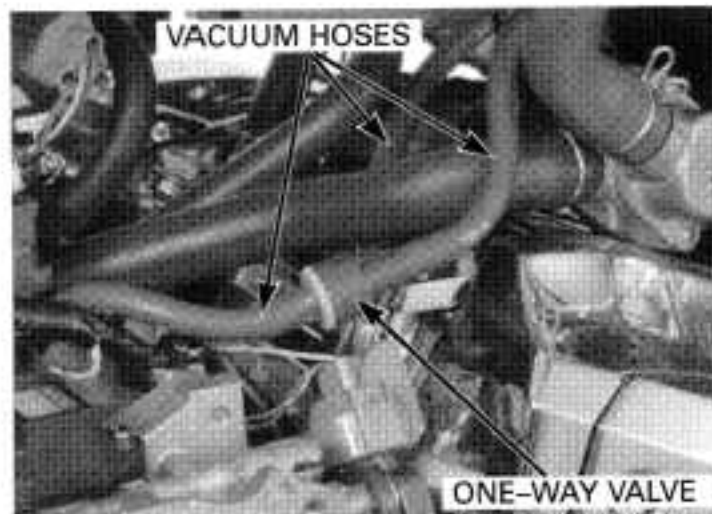

Check the one-way valve operation as follows:

- Air should flow from (A) to (B).
- Air should flow from (A) to (C).
- Air should not flow from (B) to (A).
- Air should not flow from (B) to (C).

If the operation is incorrect, replace the one-way valve.

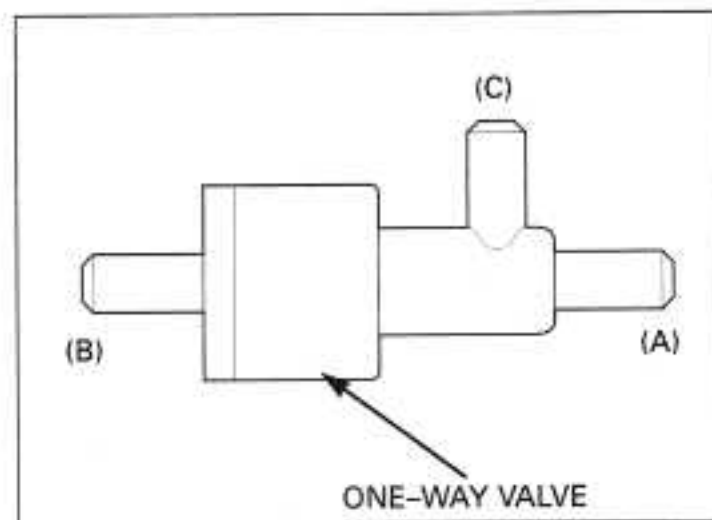

### PAIR SOLENOID VALVE

#### REMOVAL/INSTALLATION

Remove the intake duct control solenoid valve (page 5-79).

Disconnect the PAIR solenoid valve 2P connector.

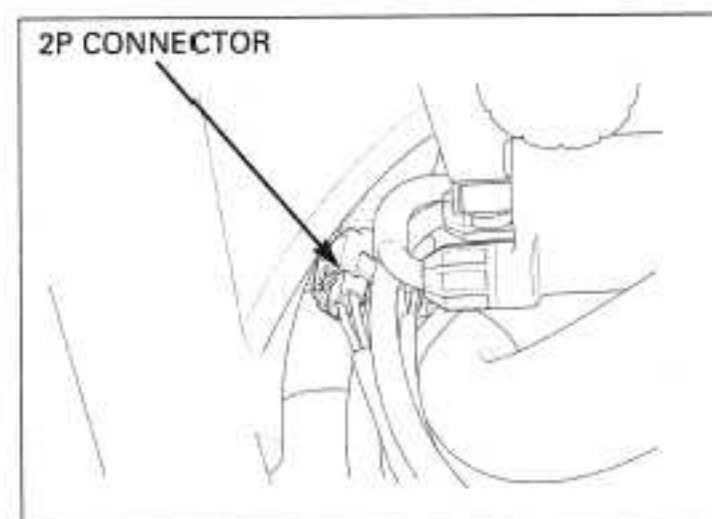

Disconnect the PAIR air suction hoses.  
Remove the bolt and PAIR solenoid valve.

Installation is in the reverse order of removal.

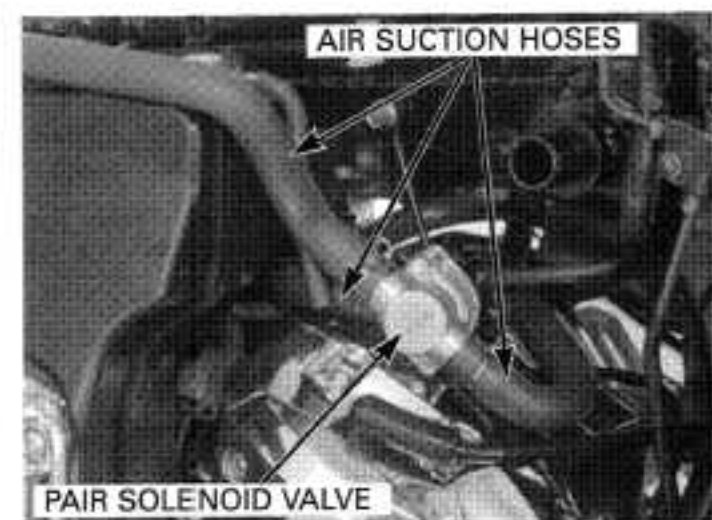



## FUEL SYSTEM (Programmed Fuel Injection)

### INSPECTION

Remove the PAIR solenoid valve.

Check that the air should not flow from (A) to (B), only when the 12-V battery is connected to the PAIR solenoid valve terminals.

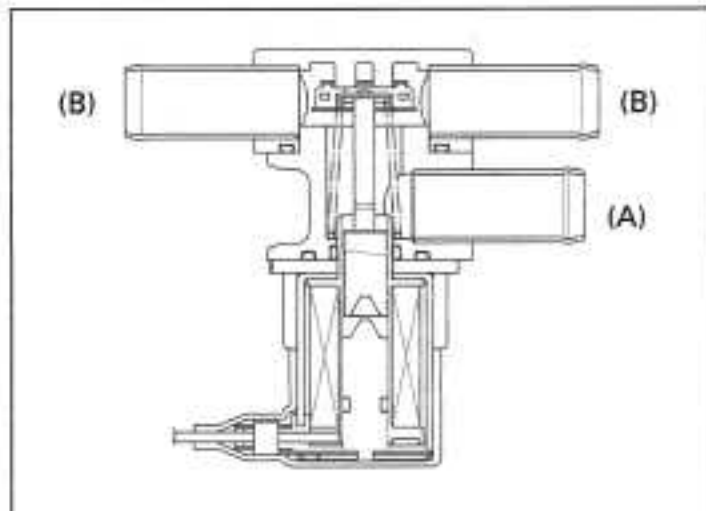

Check the resistance between the terminals of the PAIR solenoid valve.

**STANDARD: 20 – 24  $\Omega$  (20 °C/68°F)**

If the resistance is out of specification, replace the PAIR solenoid valve.

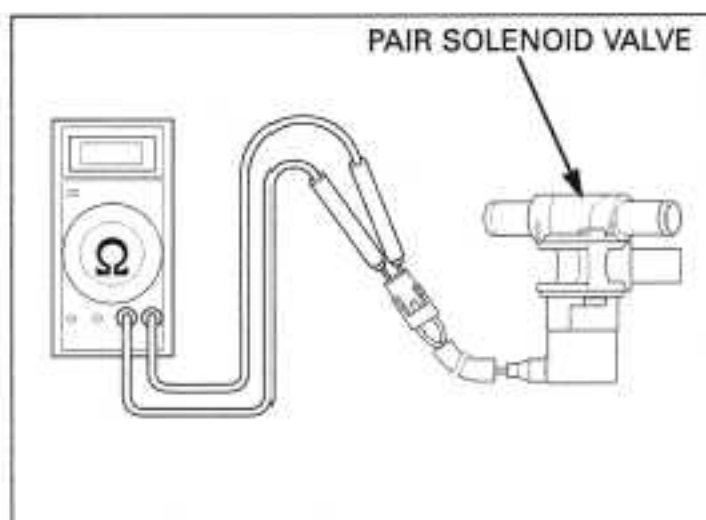

## PAIR CHECK REED VALVE

### REMOVAL/INSTALLATION

Remove the fuel tank (page 5-56).  
Remove the front and rear ignition coils (page 17-5).  
Remove the bolts and PAIR check reed valve cover.

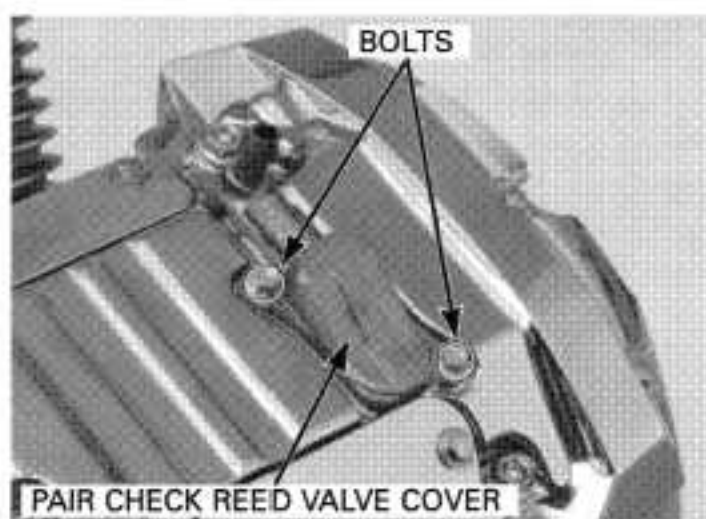

Remove the PAIR check reed valve.  
Installation is in the reverse order of removal.

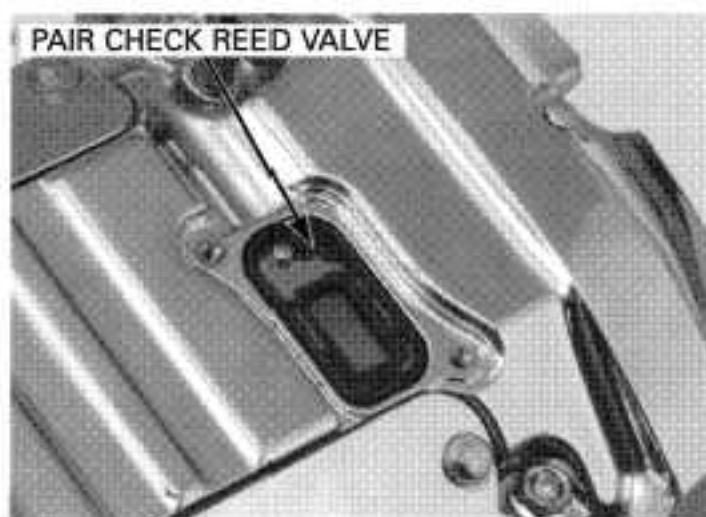



**INSPECTION**

Check the reed valve for damage or fatigue.  
 Replace if necessary.  
 Replace the reed valve if the seat rubber is cracked, deteriorated or damaged, or if there is clearance between the reed and seat.



**EVAP PURGE CONTROL VALVE (CALIFORNIA TYPE ONLY)**

**REMOVAL/INSTALLATION**

Disconnect the EVAP purge control valve 2P black connector.  
 Disconnect the air hoses from the EVAP purge control valve.  
 Remove the bolt and EVAP purge control valve bracket assembly.

Installation is in the reverse order of removal.

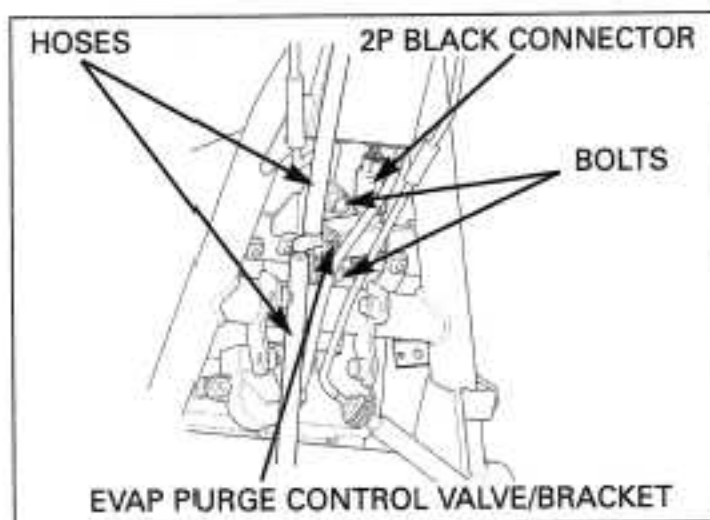

**INSPECTION**

Remove the EVAP purge control valve.

Check that the air should not flow from (A) to (B), only when the 12-V battery is connected to the EVAP purge control valve terminals.

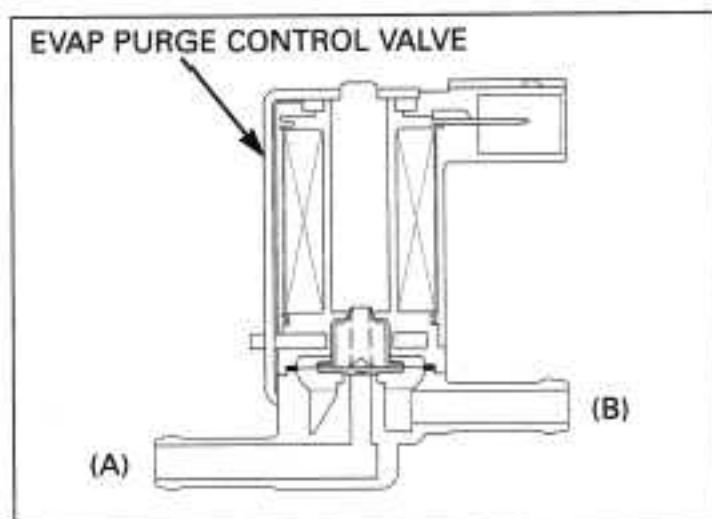

Check the resistance between the terminals of the EVAP purge control valve.

**STANDARD: 30 - 34 Ω (20 °C/68°F)**

If the resistance is out of specification, replace the EVAP purge control valve.

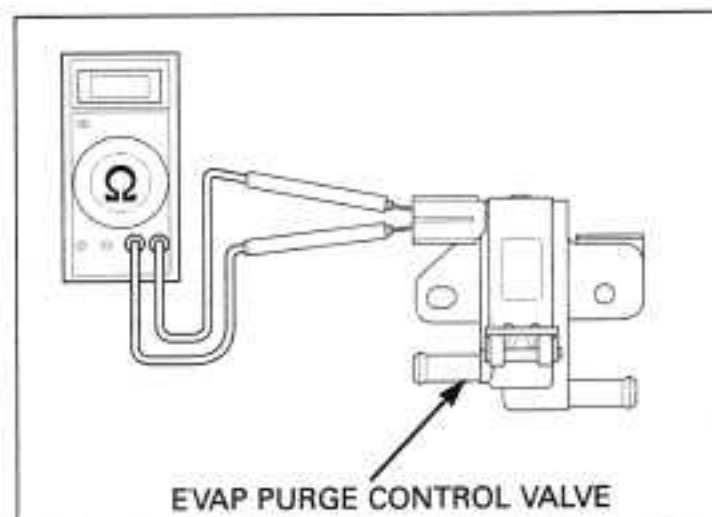

## O<sub>2</sub> SENSOR (CALIFORNIA TYPE ONLY)

### REMOVAL/INSTALLATION

#### NOTICE

*Do not service the O<sub>2</sub> sensor while it is hot.*

- *Handle the O<sub>2</sub> sensor with care.*
- *Do not get grease, oil or other materials in the O<sub>2</sub> sensor air hole.*

Remove the seat (page 2-2).

Disconnect the rear O<sub>2</sub> sensor 4P black connector.  
Disconnect the front O<sub>2</sub> sensor 4P connector.

Remove the O<sub>2</sub> sensor wire from the frame.

Remove the front and rear O<sub>2</sub> sensor units.

#### NOTICE

- *Be careful not to damage the sensor wire.*
- *Do not use an impact wrench while removing or installing the O<sub>2</sub> sensor.*

Install the front and rear O<sub>2</sub> sensor units.  
Tighten the unit to the specified torque.

**TORQUE: 24.5 N·m (2.5 kgf·m, 18 lbf·ft)**

Route the O<sub>2</sub> sensor wires into the frame.  
Connect the rear O<sub>2</sub> sensor 4P black connector.  
Connect the front O<sub>2</sub> sensor 4P connector.

Install the seat (page 2-2).

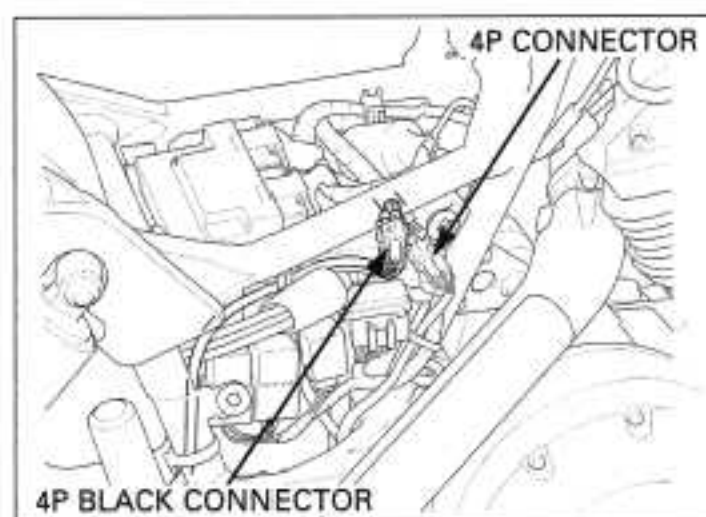
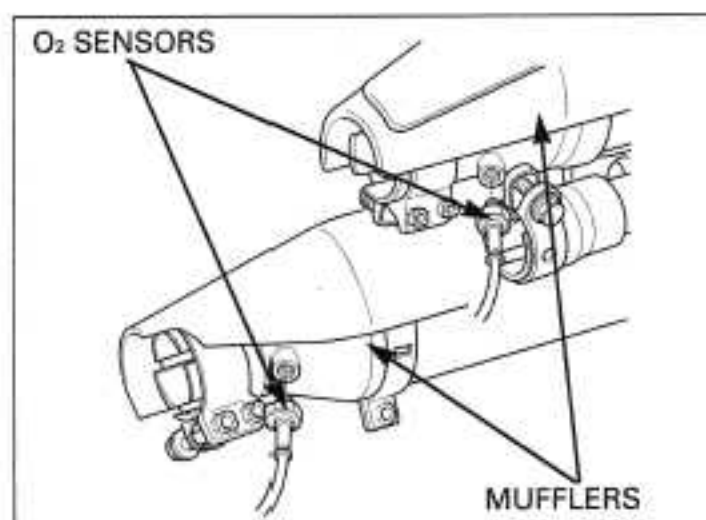
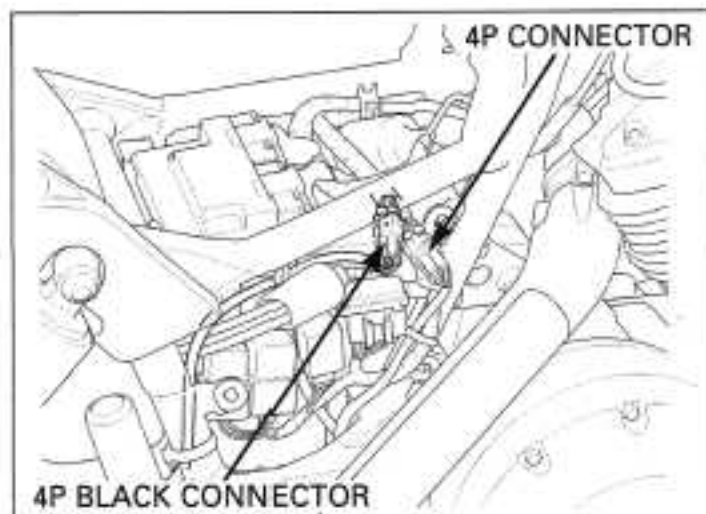

# COOLING SYSTEM

---

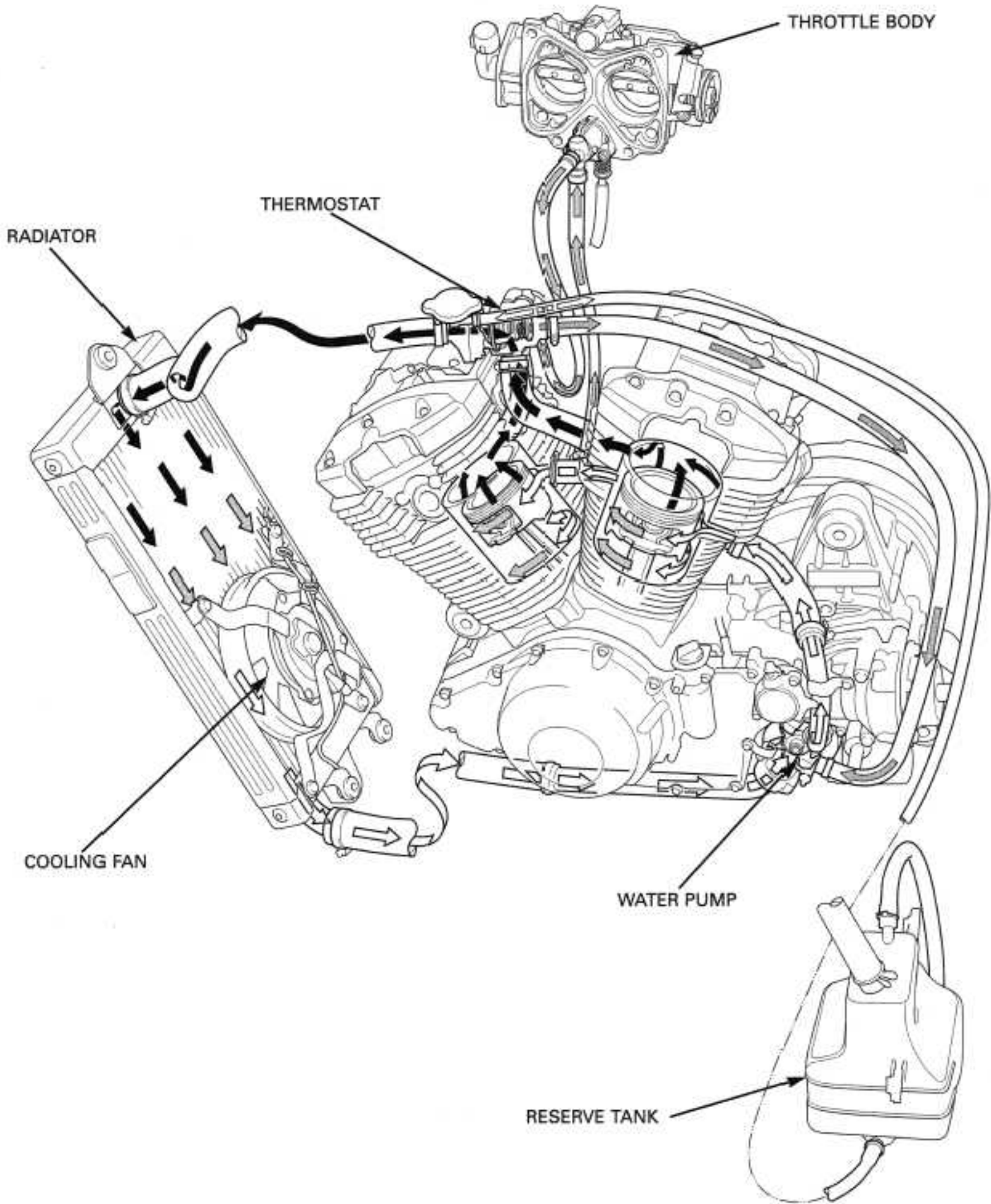

# 6. COOLING SYSTEM

SERVICE INFORMATION	6-1	RADIATOR/COOLING FAN	6-6
TROUBLESHOOTING	6-2	RADIATOR RESERVE TANK	6-9
SYSTEM TESTING	6-3	THERMOSTAT	6-9
COOLANT REPLACEMENT	6-4	WATER PUMP	6-12

## SERVICE INFORMATION

### GENERAL

#### **⚠ CAUTION**

**6**

Removing the radiator cap while the engine is hot can allow the coolant to spray out, seriously scalding you. Always let the engine and radiator cool down before removing the radiator cap.

#### **NOTICE**

Using coolant with silicate corrosion inhibitors may cause premature wear of water pump seals or blockage of radiator passages. Using tap water may cause engine damage.

- Add coolant at the reserve tank. Do not remove the radiator cap except to refill or drain the system.
- Avoid spilling coolant on painted surfaces.
- After servicing the system, check for leaks with a cooling system tester.
- If any coolant gets in your eyes, rinse them with water and consult a physician immediately.
- If any coolant is swallowed, induce vomiting, gargle and consult a physician immediately.
- If any coolant gets on your skin or clothes, rinse thoroughly with plenty of water.
- Refer to section 19 for fan motor switch and thermosensor information.

### SPECIFICATIONS

ITEM		SPECIFICATIONS
Coolant capacity	Radiator and engine	2.60 liter (2.75 US qt, 2.29 Imp qt)
	Reserve tank	0.46 liter (0.49 US qt, 0.40 Imp qt)
Radiator cap relief pressure		108 – 137 kPa (1.1 – 1.4 kgf/cm <sup>2</sup> , 16 – 20 psi)
Thermostat	Begin to open	80 – 84 °C (176 – 183 °F)
	Fully open	95 °C (203 °F)
	Valve lift	8 mm (0.3 in) minimum
Recommended antifreeze		Pro Honda HP coolant or equivalent high quality ethylene glycol antifreeze containing silicate-free corrosion inhibitors
Standard coolant concentration		1:1 mixture with soft water

### TORQUE VALUES

Water pump assembly bolt	13 N•m (1.3 kgf•m, 9 lbf•ft)
Radiator cover bolt	10 N•m (1.0 kgf•m, 7 lbf•ft)
Radiator cover side bolt	3.4 N•m (0.35 kgf•m, 2.5 lbf•ft)

### TROUBLESHOOTING

#### Engine temperature too high

- Faulty temperature unit (indicator) or thermosensor
- Thermostat stuck closed
- Faulty radiator cap
- Insufficient coolant
- Passages blocked in radiator, hoses or water jacket
- Air in system
- Faulty cooling fan motor
- Faulty fan motor switch
- Faulty water pump

#### Engine temperature too low

- Faulty temperature unit (indicator) or thermosensor
- Thermostat stuck open
- Faulty fan motor switch

#### Coolant leaks

- Faulty water pump mechanical seal
- Deteriorated O-rings
- Faulty radiator cap
- Damaged or deteriorated cylinder gasket
- Loose hose connection or clamp
- Damaged or deteriorated hoses



## SYSTEM TESTING

### COOLANT (HYDROMETER TEST)

Remove the fuel tank (page 5-56).

Remove the radiator cap.

*The engine must be cool before removing the radiator cap, or severe scalding may result.*



Test the coolant mixture with a hydrometer (see below for "Coolant specific gravity chart"). For maximum corrosion protection, a 1:1 solution of ethylene glycol and distilled water is recommended (page 6-4). Look for contamination and replace the coolant if necessary.



**Coolant specific gravity chart**

Coolant temperature °C (°F)	Coolant ratio %										
	0 (32)	5 (41)	10 (50)	15 (59)	20 (68)	25 (77)	30 (86)	35 (95)	40 (104)	45 (113)	50 (122)
5	1.009	1.009	1.008	1.008	1.007	1.006	1.005	1.003	1.001	0.999	0.997
10	1.018	1.017	1.017	1.016	1.015	1.014	1.013	1.011	1.009	1.007	1.005
15	1.028	1.027	1.026	1.025	1.024	1.022	1.020	1.018	1.016	1.014	1.012
20	1.036	1.035	1.034	1.033	1.031	1.029	1.027	1.025	1.023	1.021	1.019
25	1.045	1.044	1.043	1.042	1.040	1.038	1.036	1.034	1.031	1.028	1.025
30	1.053	1.052	1.051	1.047	1.046	1.045	1.043	1.041	1.038	1.035	1.032
35	1.063	1.062	1.060	1.058	1.056	1.054	1.052	1.049	1.046	1.043	1.040
40	1.072	1.070	1.068	1.066	1.064	1.062	1.059	1.056	1.053	1.050	1.047
45	1.080	1.078	1.076	1.074	1.072	1.069	1.066	1.063	1.060	1.057	1.054
50	1.086	1.084	1.082	1.080	1.077	1.074	1.071	1.068	1.065	1.062	1.059
55	1.095	1.093	1.091	1.088	1.085	1.082	1.079	1.076	1.073	1.070	1.067
60	1.100	1.098	1.095	1.092	1.089	1.086	1.083	1.080	1.077	1.074	1.071

## COOLING SYSTEM

### RADIATOR CAP/SYSTEM PRESSURE INSPECTION

Remove the radiator cap (page 6-3).

Wet the sealing surface of the cap, then install the cap to the tester.

*Excessive pressure can damage the cooling system components.*

*Do not exceed 137 kPa (1.4 kgf/cm<sup>2</sup>, 20psi).*

Pressure test the radiator cap. Replace the radiator cap if it does not hold the pressure, or if relief pressure is too high or too low. It must hold the specified pressure for at least 6 seconds.

#### RADIATOR CAP RELIEF PRESSURE:

**108 - 137 kPa (1.1 - 1.4 kgf/cm<sup>2</sup>, 16 - 20 psi)**

Pressurize the radiator, engine and hoses, and check for leaks.

Repair or replace components if the system will not hold the specified pressure for at least 6 seconds.

COOLING SYSTEM TESTER  
(commercially available)



COOLING SYSTEM TESTER  
(commercially available)



## COOLANT REPLACEMENT

The effectiveness of coolant decreases with the accumulation of rust or if there is a change in the mixing proportion during usage. Therefore, for best performance change the coolant regularly as specified in the maintenance schedule.

Mix only distilled, low mineral water with the antifreeze.

#### RECOMMENDED MIXTURE:

**1:1 (distilled water and antifreeze)**

#### RECOMMENDED ANTIFREEZE:

**Pro Honda HP coolant or an equivalent high quality ethylene glycol antifreeze containing silicate-free corrosion inhibitors**

#### NOTICE

*Using coolant with silicate corrosion inhibitors may cause premature wear of water pump seals or blockage of radiator passages. Using tap water may cause engine damage.*

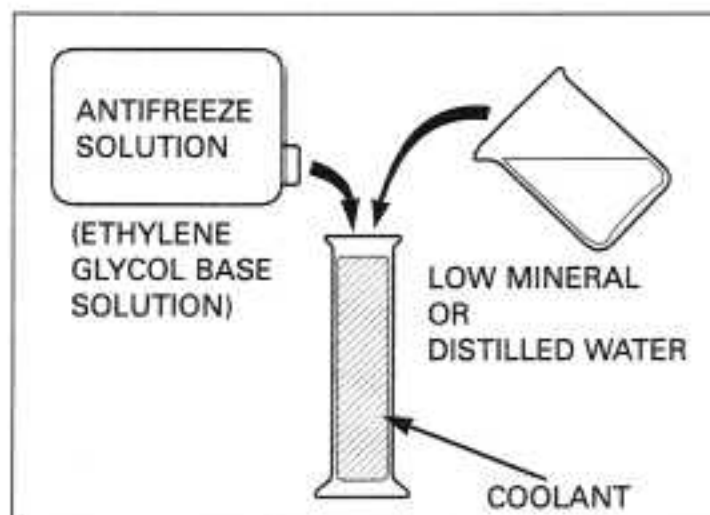

**REPLACEMENT/AIR BLEEDING**

**NOTE:**

When filling the system or reserve tank with coolant (checking the coolant level), place the motorcycle in a vertical position on a flat, level surface.

Remove the fuel tank (page 5-56).

Remove the radiator cap.

Remove the drain bolt on the water pump and drain the system coolant.

Reinstall the drain bolt with a new sealing washer.

Place a suitable container under the siphon hose joint of the reserve tank.

Disconnect the siphon hose from the reserve tank and drain the reserve coolant.

Empty the coolant and rinse the inside of the reserve tank with water.

Reconnect the siphon hose.

Fill the system with the recommended coolant through the filler opening up to the filler neck.

*The engine must be cool before servicing the cooling system, or severe scalding may result.*

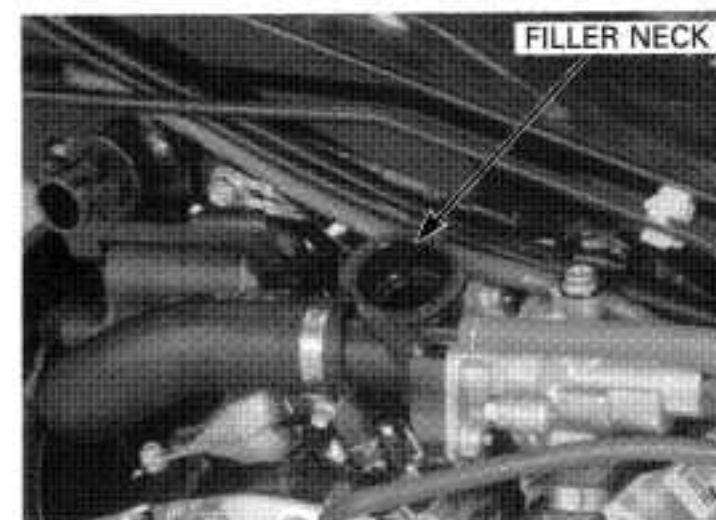
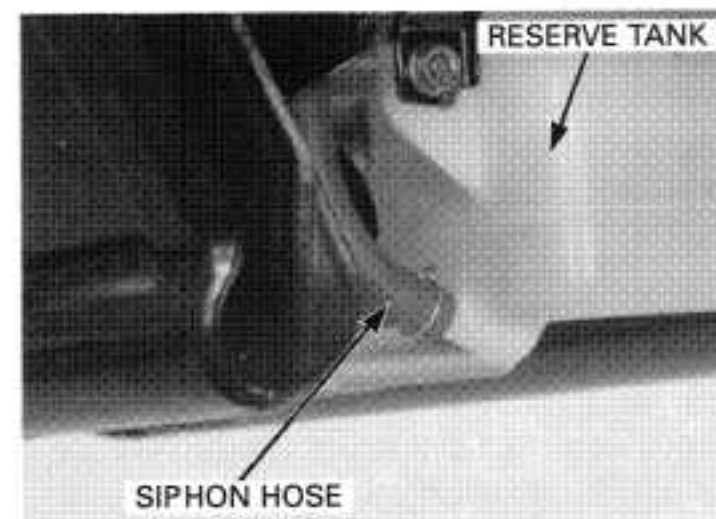
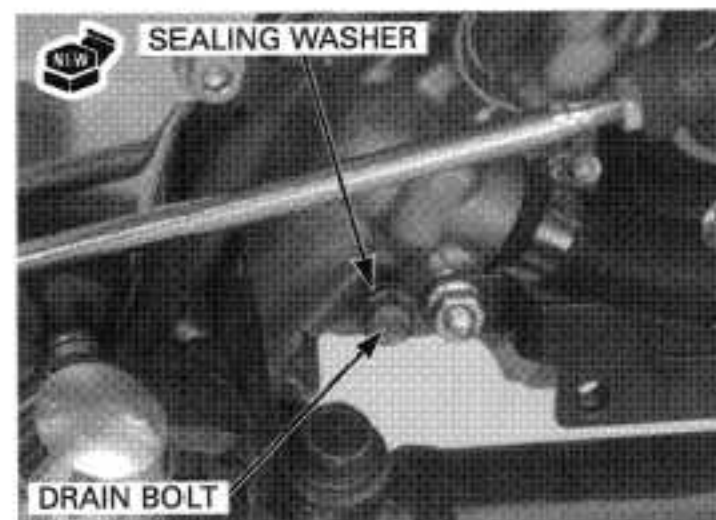



## COOLING SYSTEM

Remove the reserve tank cap and fill the reserve tank to the upper level line.

Bleed air from the system as follows:

1. Shift the transmission into neutral.  
Start the engine and let it idle for 2 – 3 minutes.
2. Snap the throttle three or four times to bleed air from the system.
3. Stop the engine and add coolant to the proper level if necessary. Reinstall the radiator cap.
4. Check the level of coolant in the reserve tank and fill to the upper level if it is low.

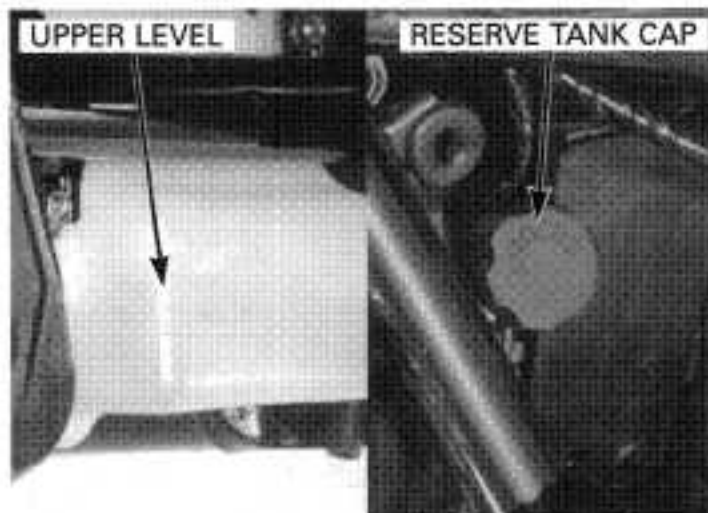

## RADIATOR/COOLING FAN

### REMOVAL

Drain the coolant (page 6-5).

*Be careful not to damage the radiator fins while servicing the radiator and fan.*

Loosen the band screw.  
Disconnect the lower radiator hose from the radiator.

Remove the bolts from the radiator bottom.

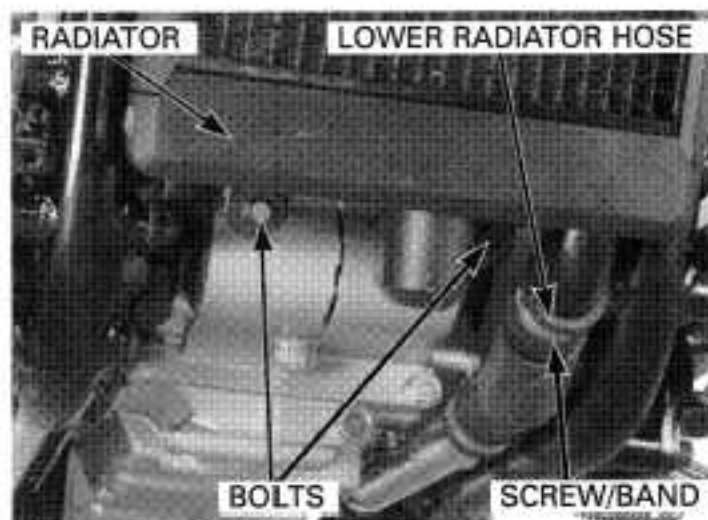

Loosen the band screw.  
Disconnect the upper radiator hose from the radiator.

Remove the radiator mounting bolt and washer.

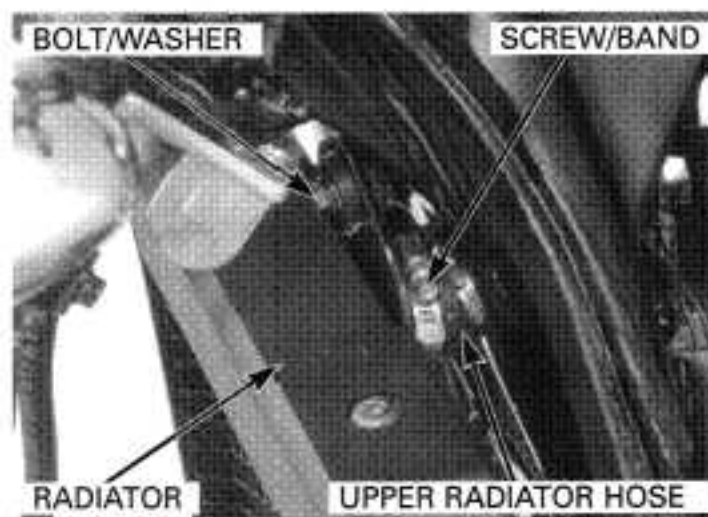

Disconnect the fan motor switch 2P connector and remove it from the tab on the frame.

Remove the radiator.

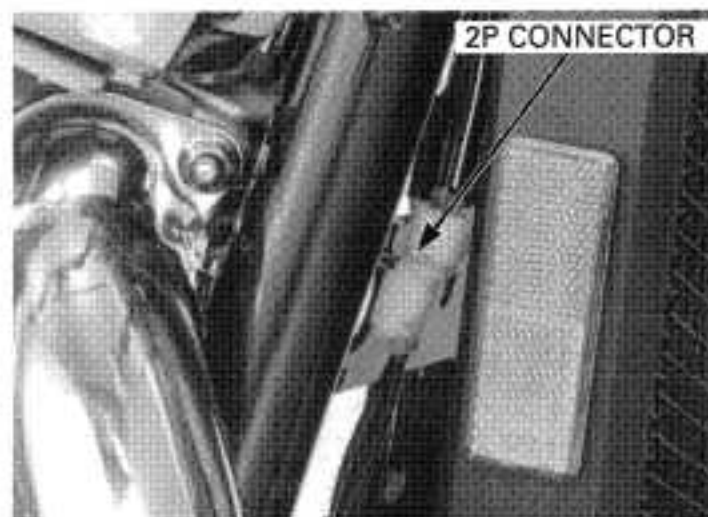

**DISASSEMBLY**

Remove the radiator cover bolts, radiator lower cover, upper cover and grill.

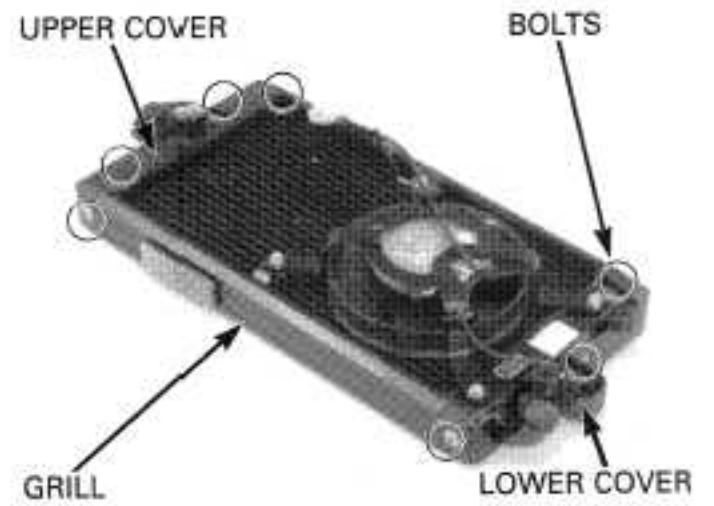

Disconnect the fan motor switch connector and remove the wires from the clamps. Remove the bolts and the ground terminal. Remove the fan motor assembly from the radiator.

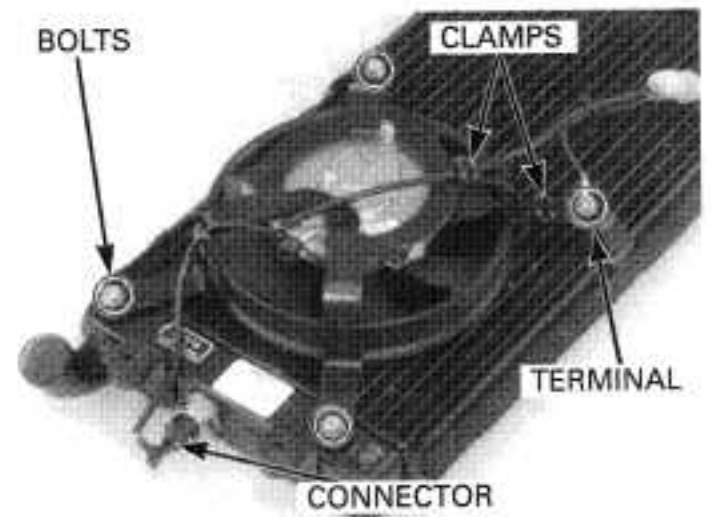

Remove the nut and cooling fan from the motor.

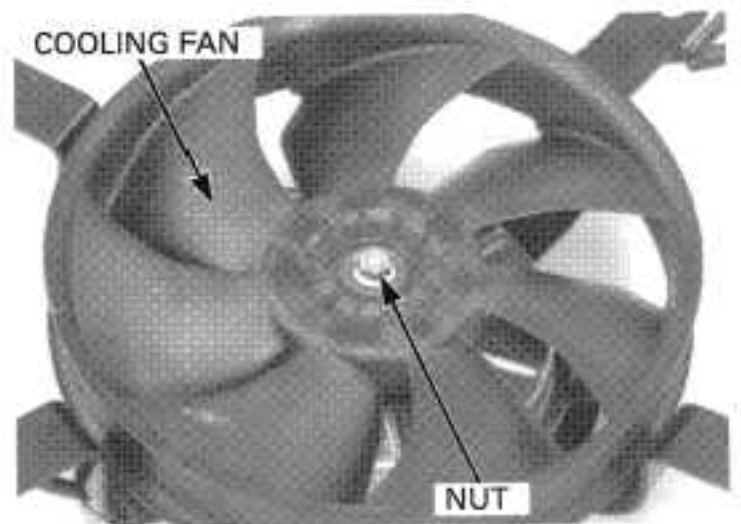

Remove the nuts and the fan motor from the shroud. For fan motor switch information, refer to page 19-14.

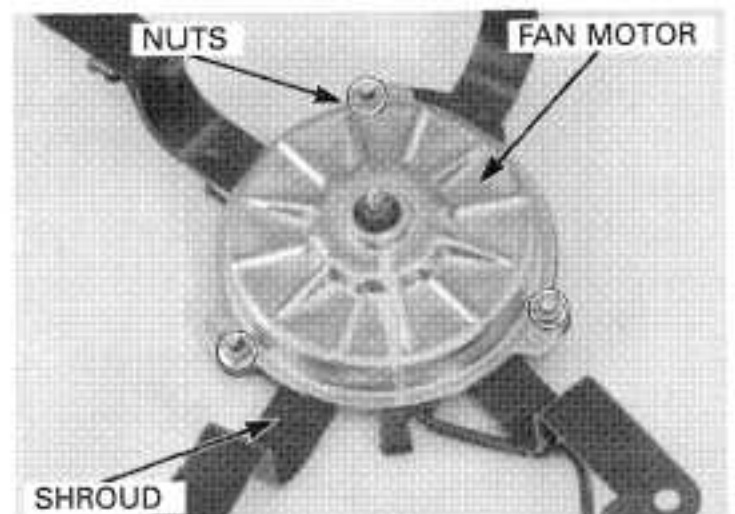



## COOLING SYSTEM

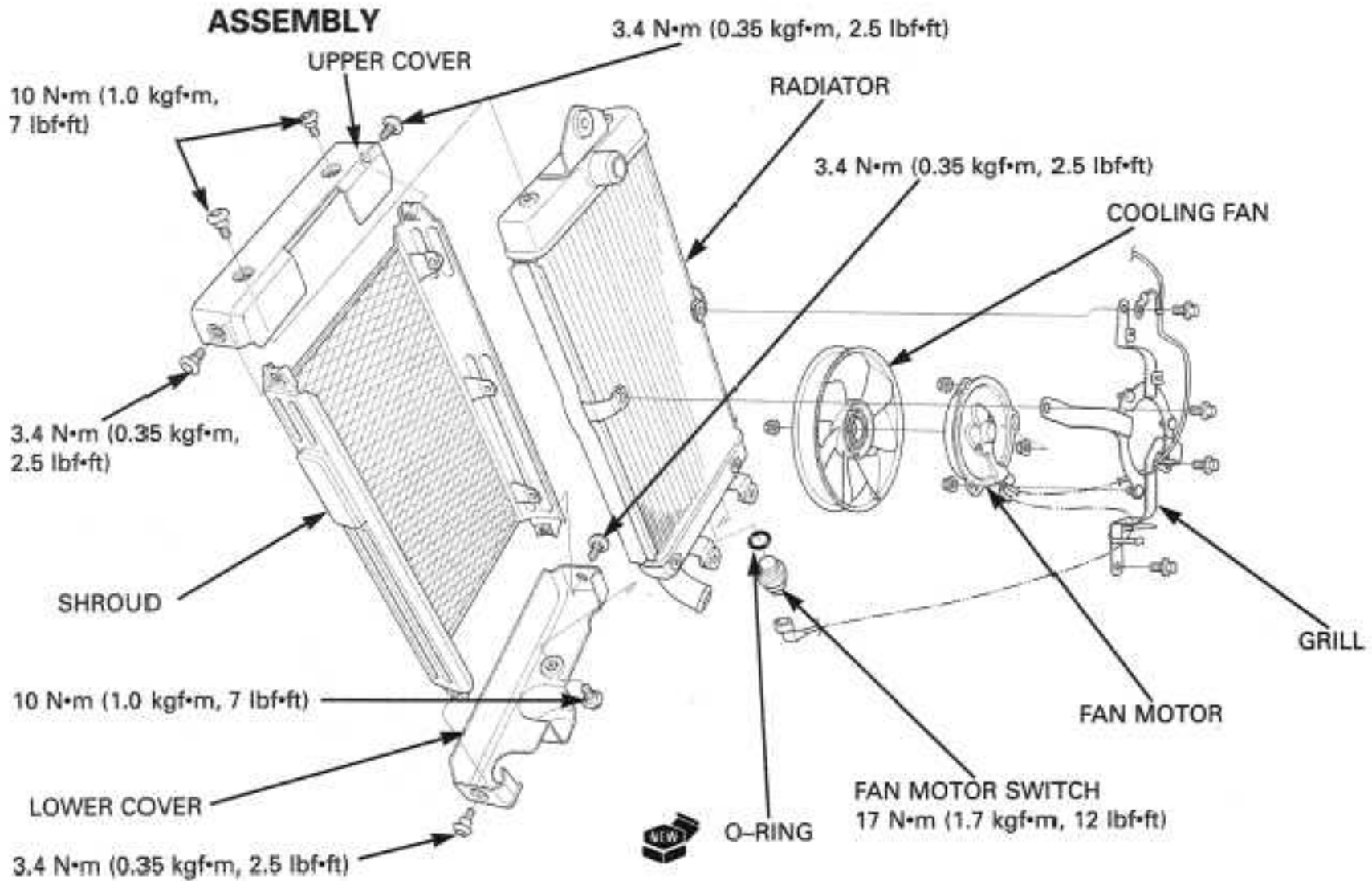

Install the fan motor onto the shroud with the drain hose facing down as shown, and tighten the nuts securely.

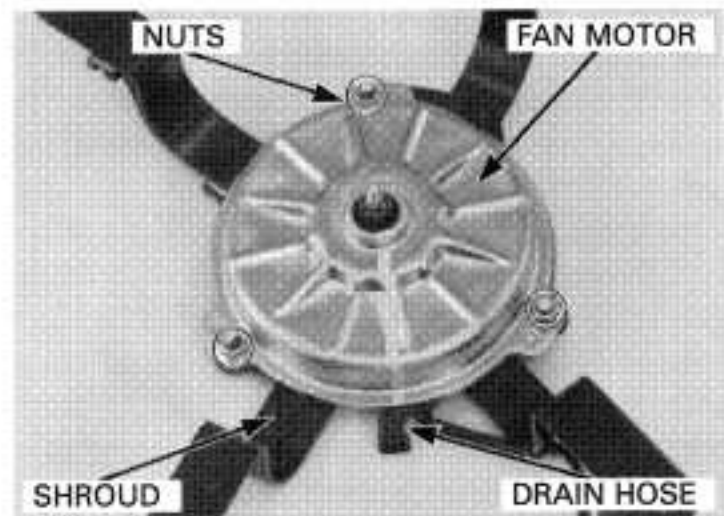

Install the cooling fan onto the motor shaft, aligning the flat surfaces. Install and tighten the nut securely.

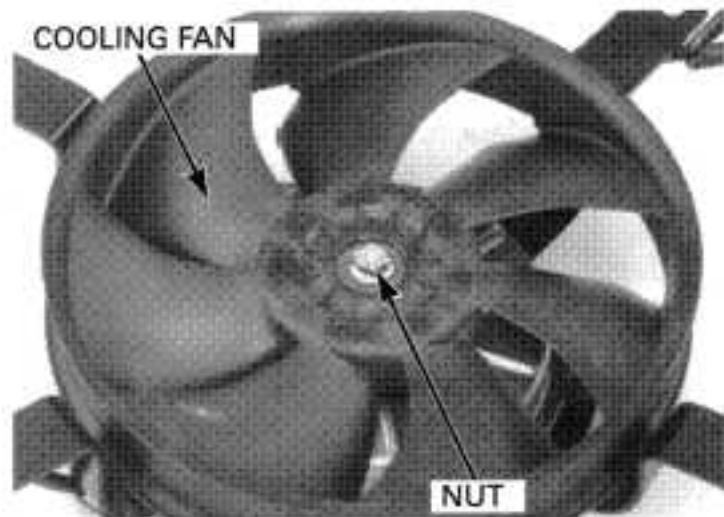

Install the fan motor assembly onto the radiator and tighten the mounting bolts with the ground terminal.

Route the wires properly, clamp the wires and connect the switch connector.

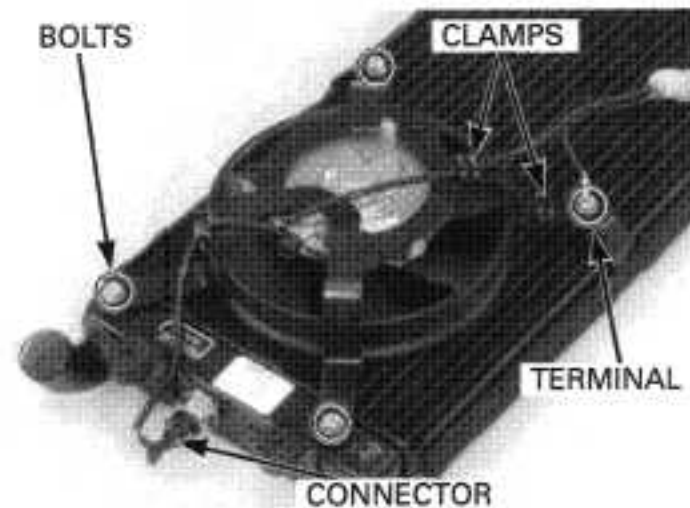

Install the radiator grill, lower cover and upper cover. Install and tighten the radiator cover bolts to the specified torque.

**TORQUE:**

Radiator cover bolt: 10 N·m (1.0 kgf·m, 7 lbf·ft)

Radiator cover side bolt: 3.4 N·m (0.35 kgf·m, 2.5 lbf·ft)

**INSTALLATION**

Installation is in the reverse order of removal.

Fill and bleed the cooling system (page 6-5).

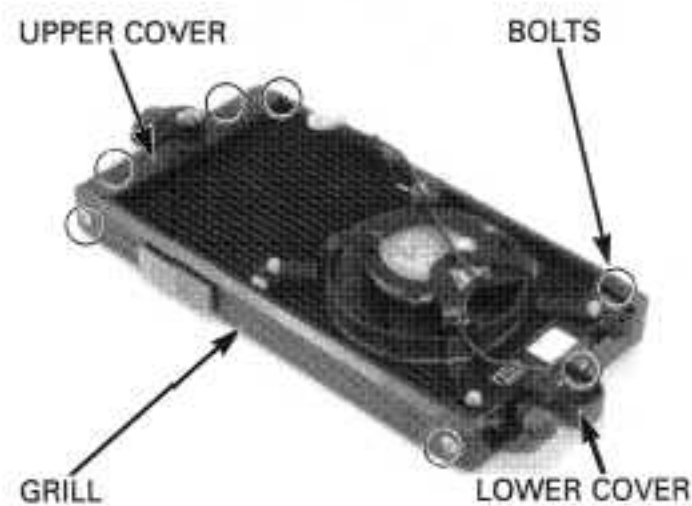

**RADIATOR RESERVE TANK**

**REMOVAL/INSTALLATION**

Drain the coolant from the reserve tank (page 6-5).

Remove the bolts.

Disconnect the filler hose and remove the breather hose from the frame clamp.

Remove the reserve tank out of the frame to the rear.

Install the removed parts in the reverse order of removal.

Fill the tank with coolant (page 6-5).

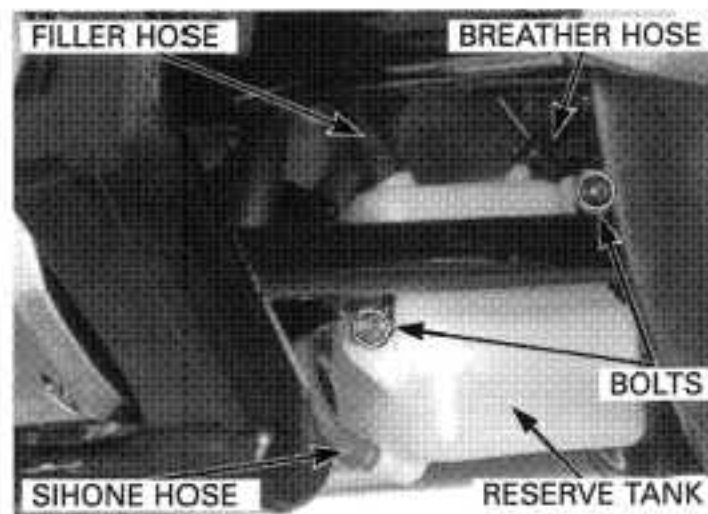

**THERMOSTAT**

**REMOVAL**

Drain the coolant (page 6-5).

Remove the fuel tank (page 5-56).

Remove the bolt and thermostat housing.

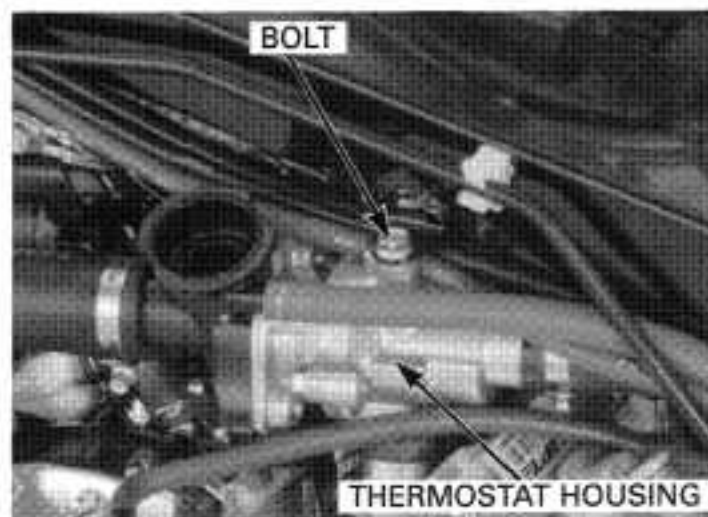

## COOLING SYSTEM

Remove the filler neck bolts and filler neck/thermostat housing cover.

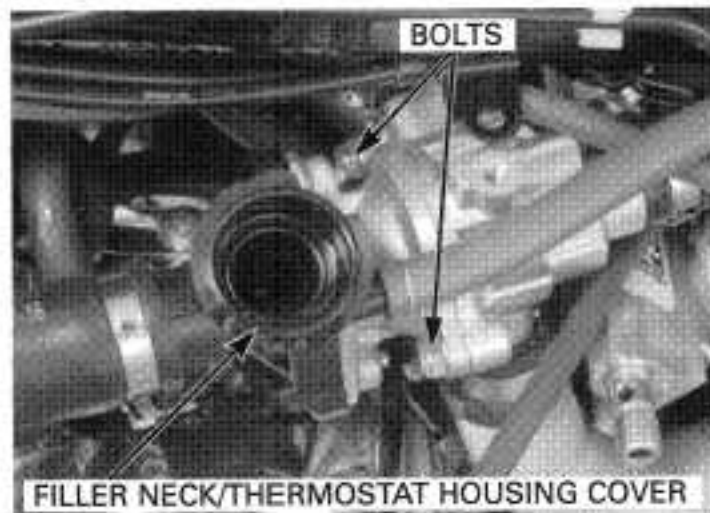

Remove the thermostat from the housing.

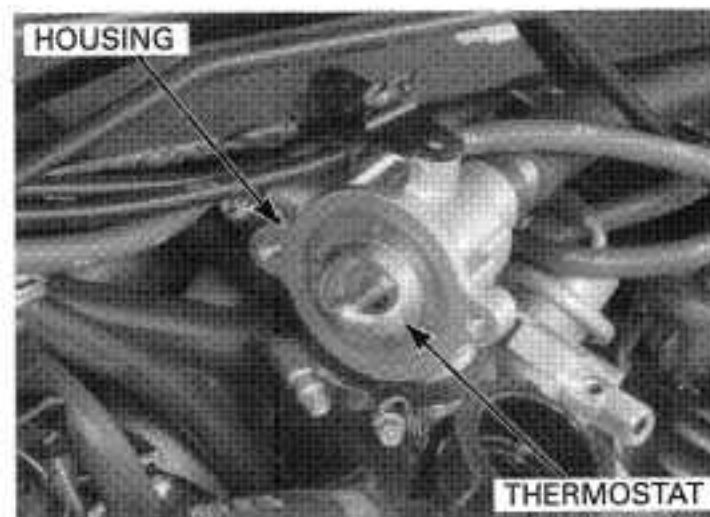

If the filler neck/thermostat housing cover is to be removed, loosen the band screws and disconnect the upper radiator hose from the housing.



If the thermostat housing is to be removed, disconnect the thermosensor connector (page 5-74). Loosen the band screws and disconnect the water hoses from the housing.

Refer to page 19-14 for thermosensor (coolant temperature indicator) information.

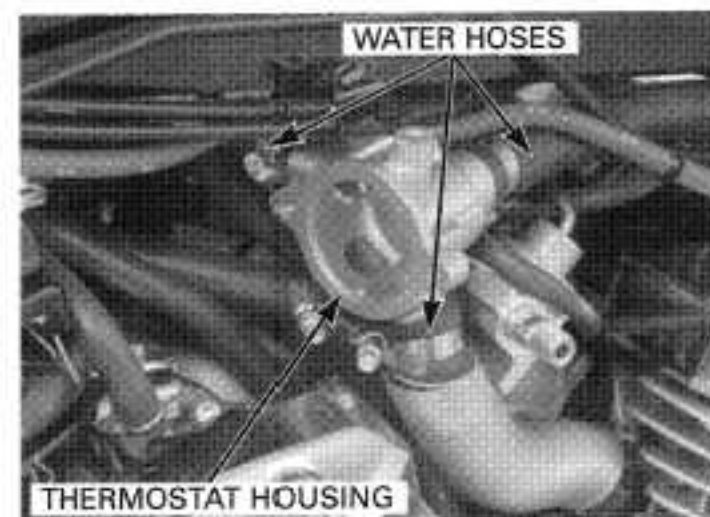

**INSPECTION**

Visually inspect the thermostat for damage.  
 Replace the thermostat if the valve stays open at room temperature.

*Wear insulated gloves and adequate eye protection. Keep flammable materials away from the electric heating element. Do not let the thermostat or thermometer touch the pan, or you will get false readings.*

Heat a container of water with an electric heating element for 5 minutes.  
 Suspend the thermostat in the heated water to check its operation.

Replace the thermostat if the valve responds at temperatures other than specified.

**THERMOSTAT BEGINS TO OPEN:**  
 80 - 84 °C (176 - 183 °F)  
**VALVE LIFT:**  
 8 mm (0.3 in) minimum at 95 °C (203 °F)

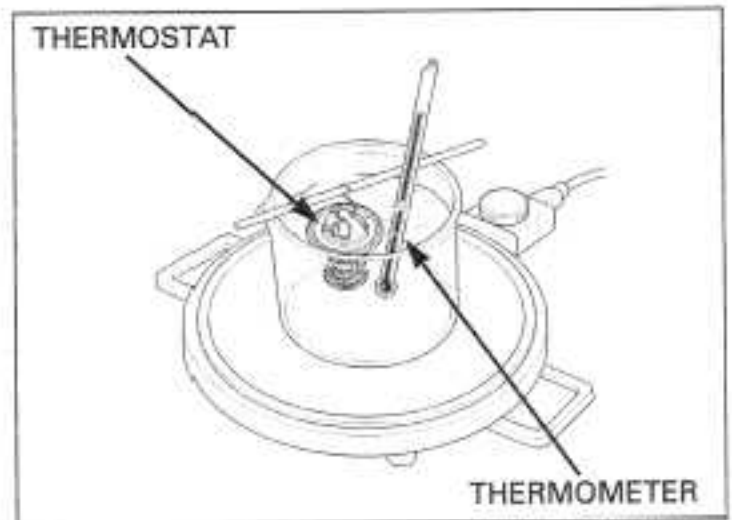
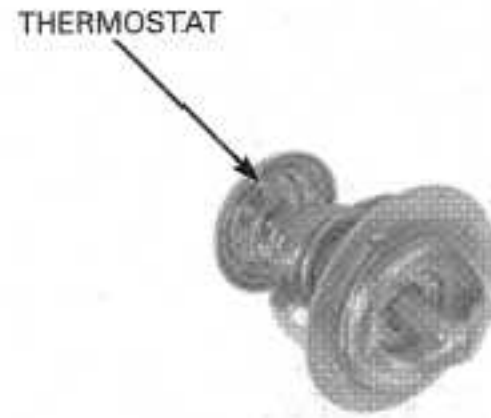

**INSTALLATION**

Install the thermostat into the housing with its hole facing upright.  
 Align the thermostat flange with the groove in the housing upper surface. Make sure the thermostat is securely installed.

Install the new O-ring on the thermostat housing cover.

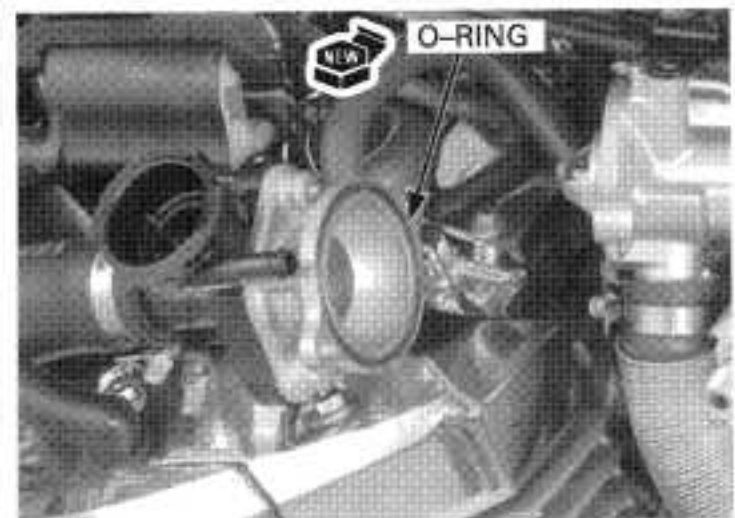
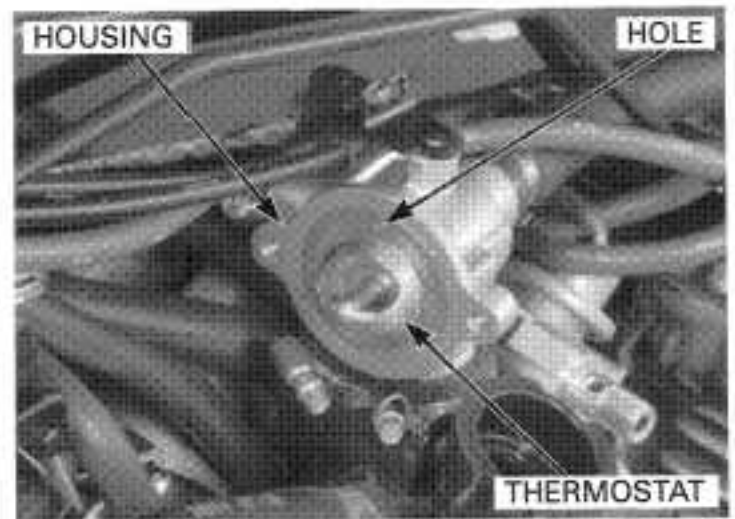



## COOLING SYSTEM

Install the thermostat housing cover and tighten the cover bolts.

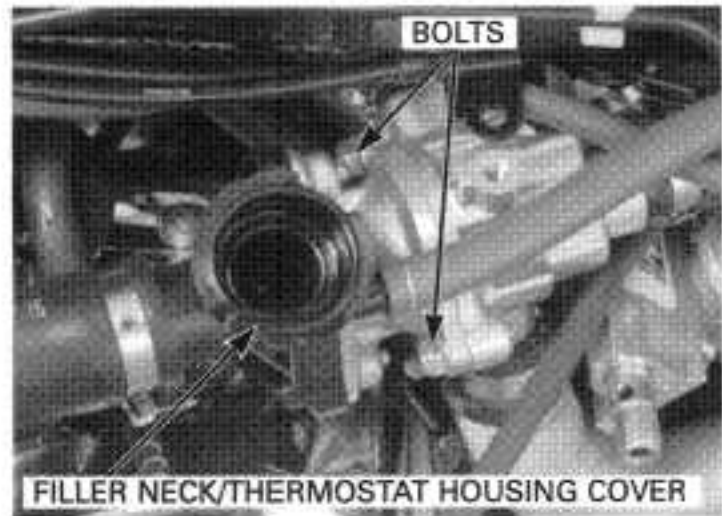

Align the tab on thermostat housing with the groove on the frame.  
Install and tighten the bolt securely.

Install the fuel tank (page 5-56).

Fill and bleed the cooling system (page 6-5).

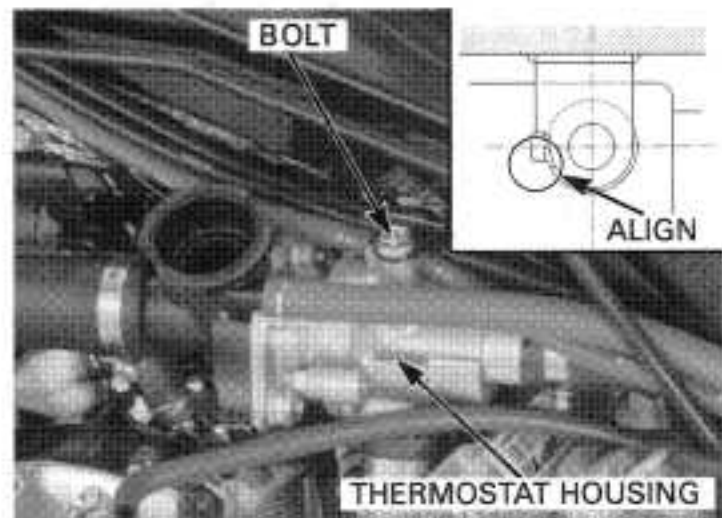

## WATER PUMP

### MECHANICAL SEAL INSPECTION

Remove the left crankcase rear cover (page 2-3).

Inspect the telltale hole for signs of coolant leakage. If there is leakage, the mechanical seal is defective and you must replace the water pump as an assembly.

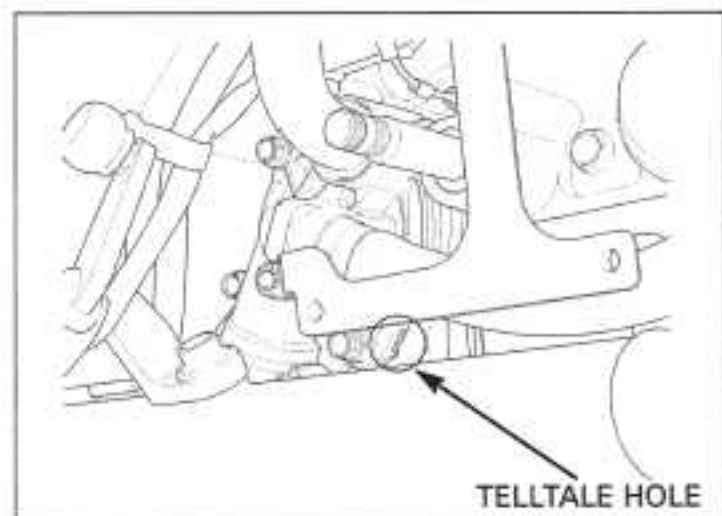

### REMOVAL

Drain the coolant (page 6-5).

Remove the bolt and water pipe/O-ring from the water pump.

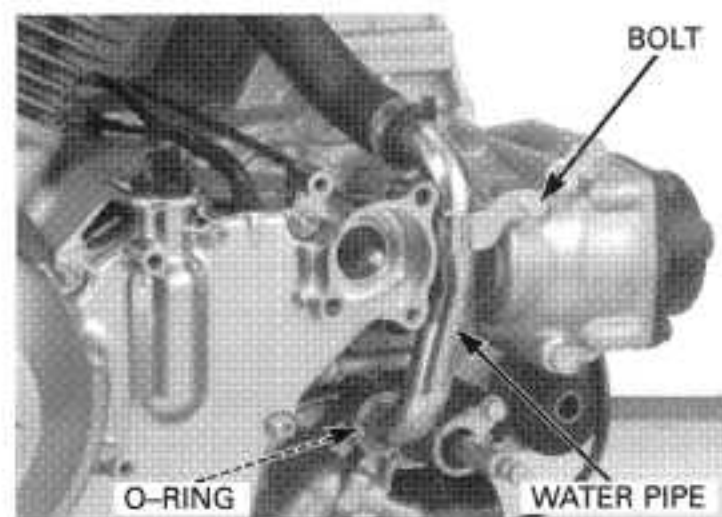



Remove the water pump cover bolts, water pump assembly bolts, water pump cover and O-ring.

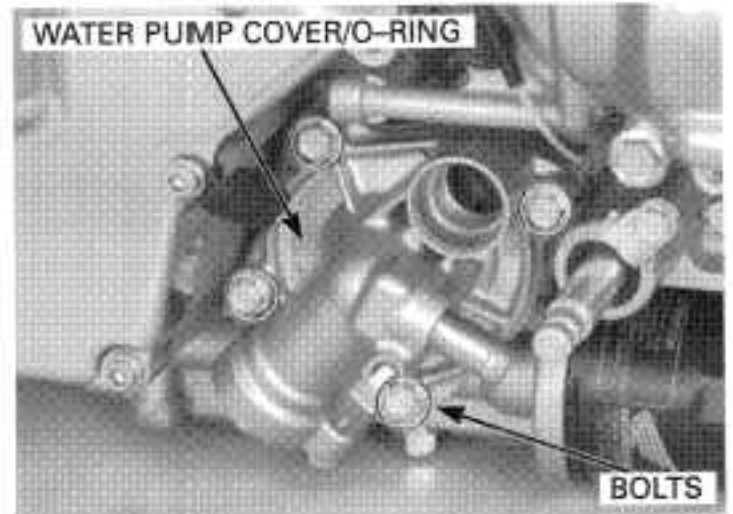

Remove the O-ring and water pump from the crankcase.

**INSTALLATION**

Apply engine oil to a new O-ring and install it onto the stepped portion of the water pump.

Install the water pump into the crankcase while aligning the water pump shaft groove with the oil pump shaft end.

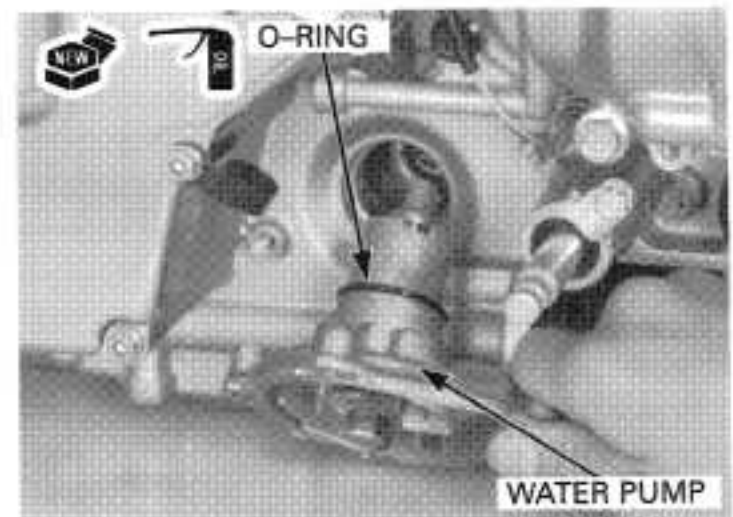

Align the mounting bolt holes in the water pump and crankcase.  
Make sure the water pump is securely installed.

Install a new O-ring into the groove in the water pump.

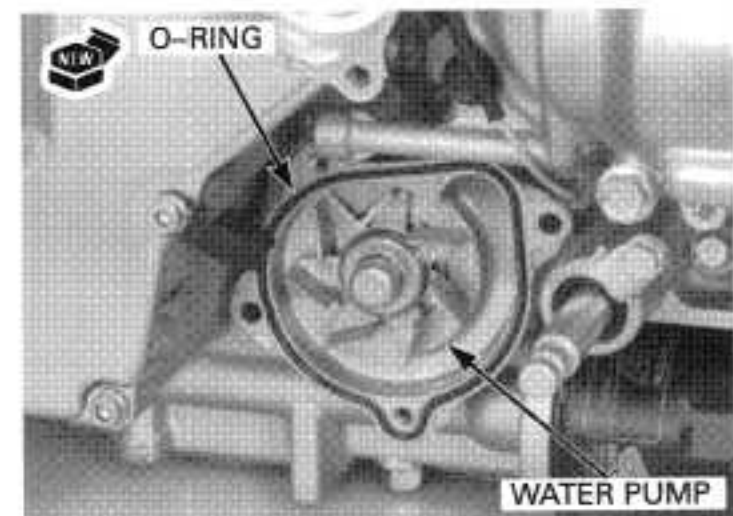

Install the water pump cover and tighten the water pump cover bolts and water pump assembly bolts securely.

**TORQUE: 13 N·m (1.3 kgf·m, 9 lbf·ft)**

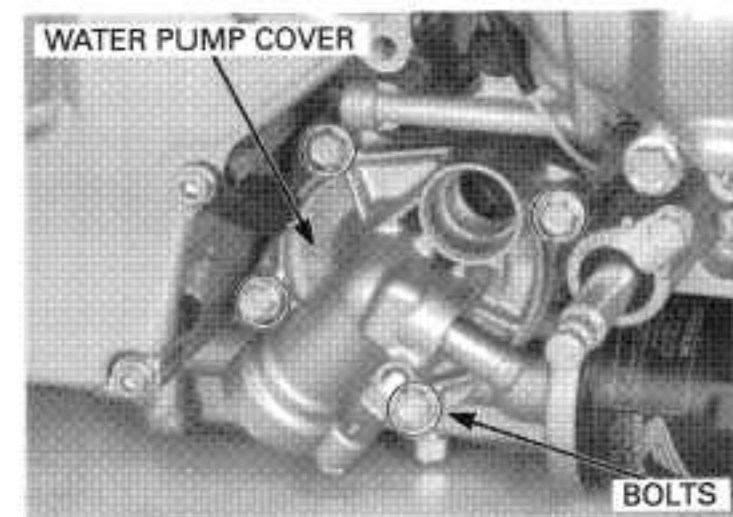

## COOLING SYSTEM

---

Install a new O-ring to the water pipe.

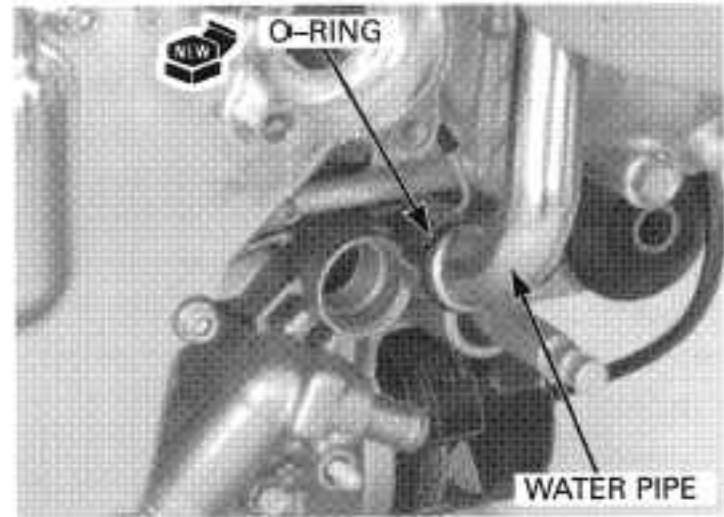

Install the water pipe to the water pump and tighten the bolt securely.

Fill and bleed the cooling system (page 6-5).

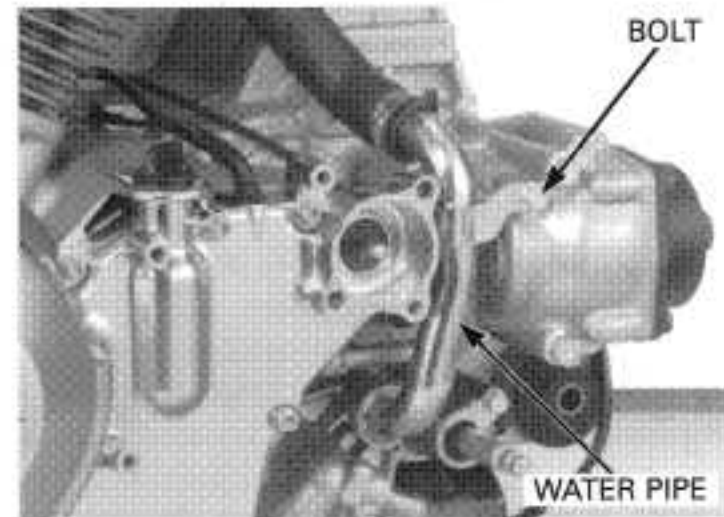

## ENGINE REMOVAL/INSTALLATION

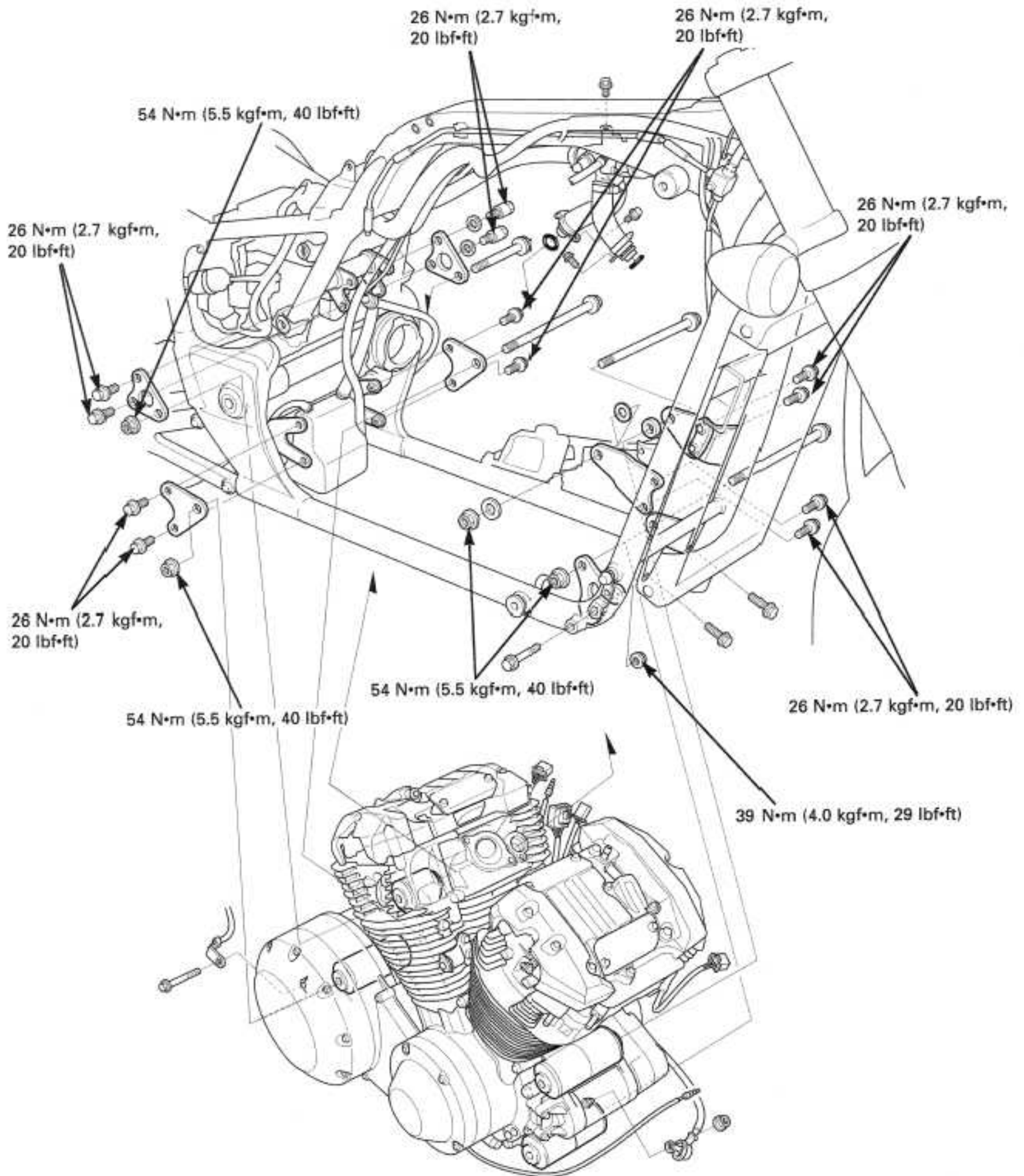

# 7. ENGINE REMOVAL/INSTALLATION

SERVICE INFORMATION

7-1

ENGINE INSTALLATION

7-9

ENGINE REMOVAL

7-3

## SERVICE INFORMATION

### GENERAL

- Do not support the engine using the oil filter.
- A floor jack or other adjustable support is required to support and maneuver the engine.
- It is recommended to use two steel poles to help remove and install the engine. These poles will go through the front and rear upper engine mounts, and the engine can then be carried out of the frame. See the illustrations below for pole specifications.

#### FRONT:

Pole: 1371 mm (54 in)  
Holes: 140 mm (5.5 in)  
686 mm (27 in) off center

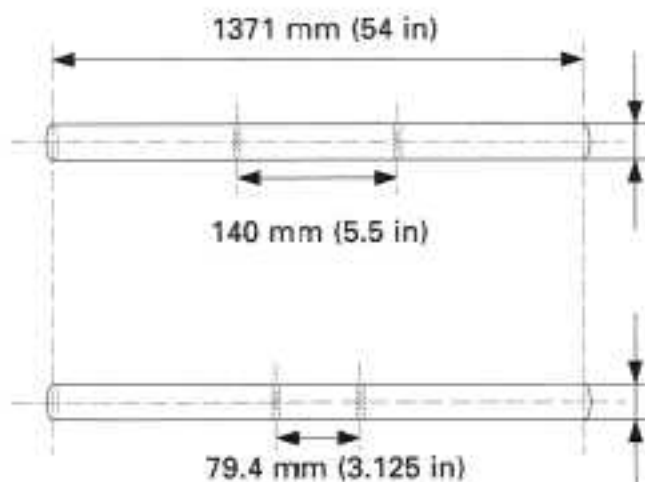

#### REAR:

Pole: 1371 mm (54 in)  
Holes: 79.4 mm (3.125 in)  
686 mm (27 in) off center

- When removing and installing the engine, tape the frame around the engine beforehand for frame protection.

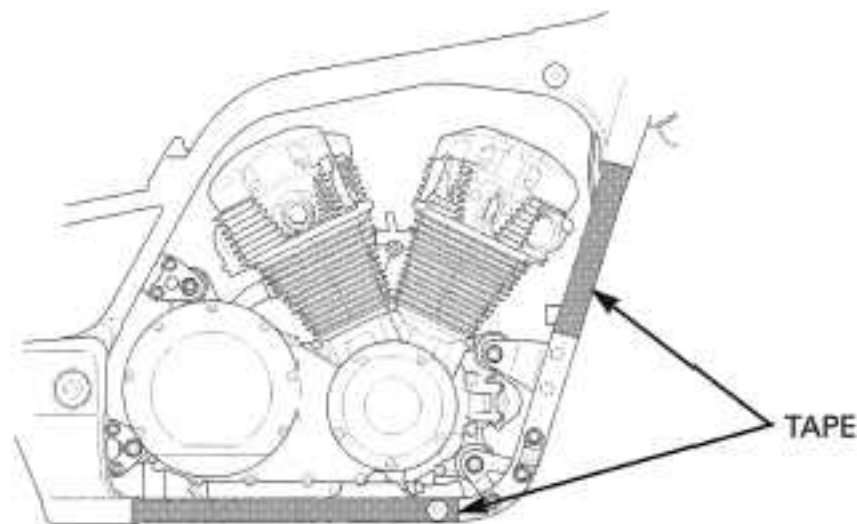

- The following components require engine removal for service.
  - Oil pump (Section 4)
  - Cylinder head/camshaft (Section 8)
  - Cylinder/piston (Section 9)
  - Crankshaft (Section 11)
  - Transmission/shift drum/shift fork (Section 11)
  - Output gear (Section 11)
- The following components can be serviced with the engine in the frame.
  - Throttle body (Section 5)
  - Water pump (Section 6)
  - Clutch/gearshift linkage (Section 10)
  - Alternator (Section 16)
  - Starter clutch/flywheel (Section 18)
  - Starter motor (Section 18)

## ENGINE REMOVAL/INSTALLATION

---

### SPECIFICATION

ITEM	STANDARD
Engine dry weight	122.5 kg (270 lbs)
Engine oil capacity at disassembly	4.5 liter (4.8 US qt, 4.0 Imp qt)
Coolant capacity (radiator and engine)	2.6 liter (2.75 US qt, 2.29 Imp qt)

### TORQUE VALUES

Front upper engine mounting nut	54 N•m (5.5 kgf•m, 40 lbf•ft)
Front lower engine mounting nut	54 N•m (5.5 kgf•m, 40 lbf•ft)
Rear upper engine mounting nut	54 N•m (5.5 kgf•m, 40 lbf•ft)
Rear lower engine mounting nut	54 N•m (5.5 kgf•m, 40 lbf•ft)
Right front upper engine hanger plate bolt	26 N•m (2.7 kgf•m, 20 lbf•ft)
Left front upper engine hanger plate bolt	26 N•m (2.7 kgf•m, 20 lbf•ft)
Right front lower engine hanger plate nut	39 N•m (4.0 kgf•m, 29 lbf•ft)
Rear upper engine hanger plate bolt	26 N•m (2.7 kgf•m, 20 lbf•ft)
Rear lower engine hanger plate bolt	26 N•m (2.7 kgf•m, 20 lbf•ft)
Starter motor cable terminal nut	7 N•m (0.7 kgf•m, 5.1 lbf•ft)



## ENGINE REMOVAL

Refer to General Service Information on page 7-1 before removing or installing the engine. Especially note the areas to tape on the frame.

Drain the engine oil (page 3-13) and coolant (page 6-5).

Support the motorcycle securely.

Remove the following:

- Exhaust system (page 2-4)
- Left step holder (page 16-10)
- Fuel tank (page 5-56)
- Throttle body (page 5-58)
- Front/rear ignition coils (page 17-5)
- Thermostat housing bolt (page 6-9)

Disconnect the following connectors:

- Alternator 3P connector
- Ignition pulse generator 2P connector
- Neutral switch connector
- Oil pressure switch connector
- Speed sensor 3P connector
- Cam pulse generator 2P black connector
- Ground cable on the right crankcase cover

Disconnect the intake duct control solenoid valve 2P connector.

Remove the bolt, intake duct control solenoid valve and vacuum chamber.

Disconnect the PAIR solenoid valve 2P connector.  
Remove the bolt and PAIR solenoid valve.

Disconnect the PAIR air hose from the rear PAIR reed valve cover.

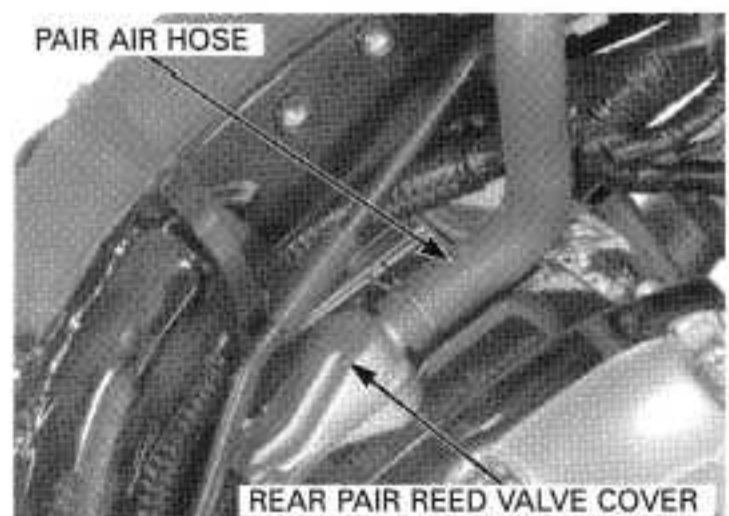
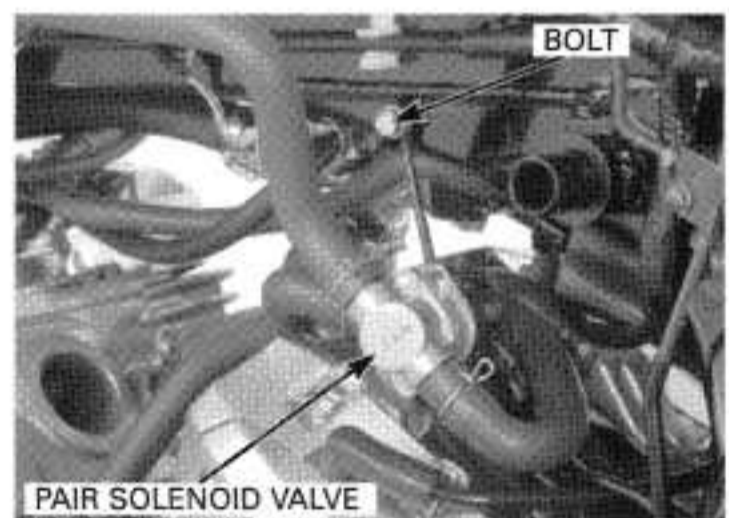
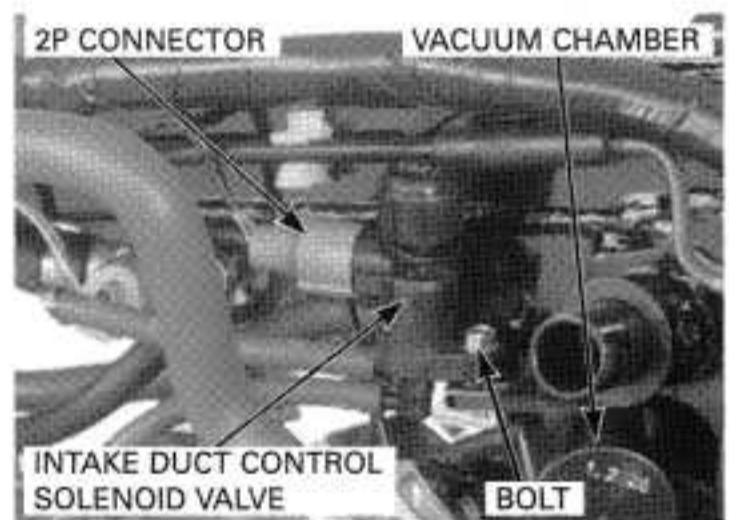

## ENGINE REMOVAL/INSTALLATION

Disconnect the PAIR air hose from the front PAIR reed valve cover and remove the PAIR assembly.

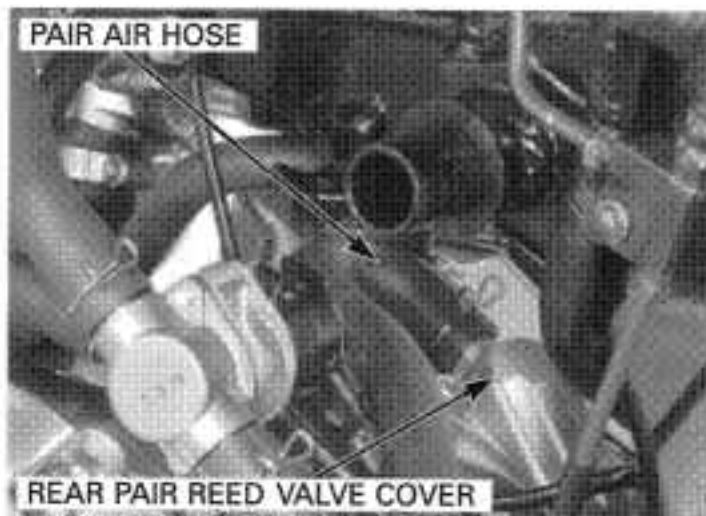

Remove the bolt, nut and left crankcase rear cover stay.

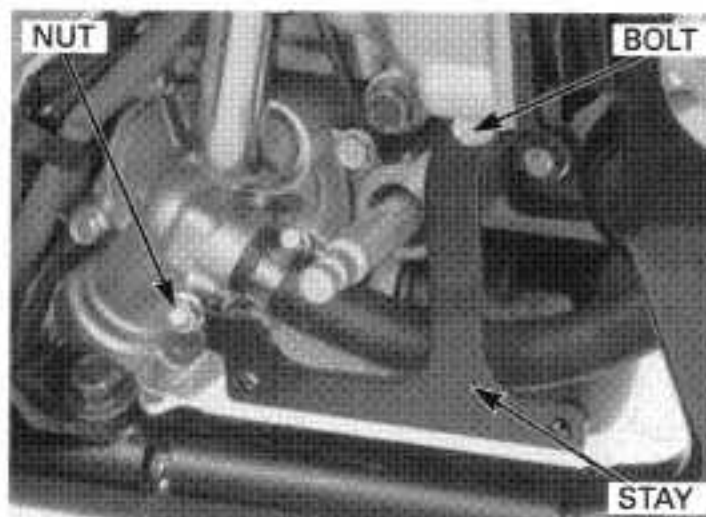

Remove the starter motor cable from the clamp.

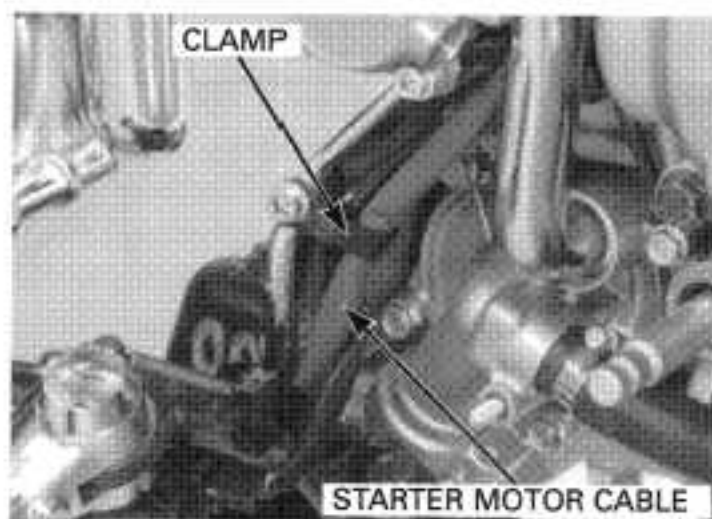

*It may be necessary to reposition the coolant hose clamp to allow the starter motor cable to be pulled under the hose.*

Remove the starter motor cable from the other clamp. Pull the starter motor cable under the rear cylinder coolant hose and away from the engine. Loosen the band screw and disconnect the lower radiator hose. Remove the water pump pipe.

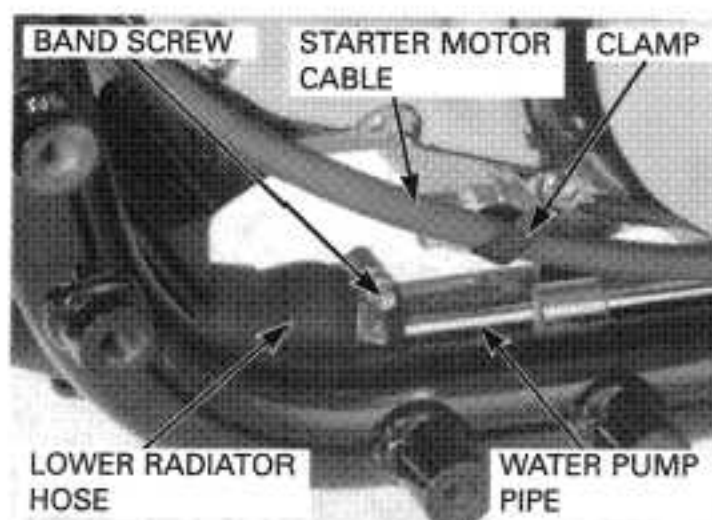

Remove the radiator mounting bolts (page 6-6).

Remove the starter motor nut and disconnect the starter motor cable from the starter motor.

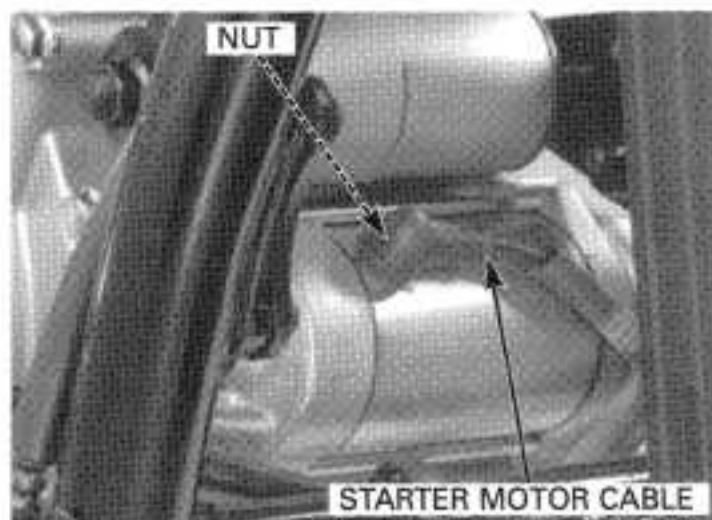

Remove the ignition switch (page 19-12).

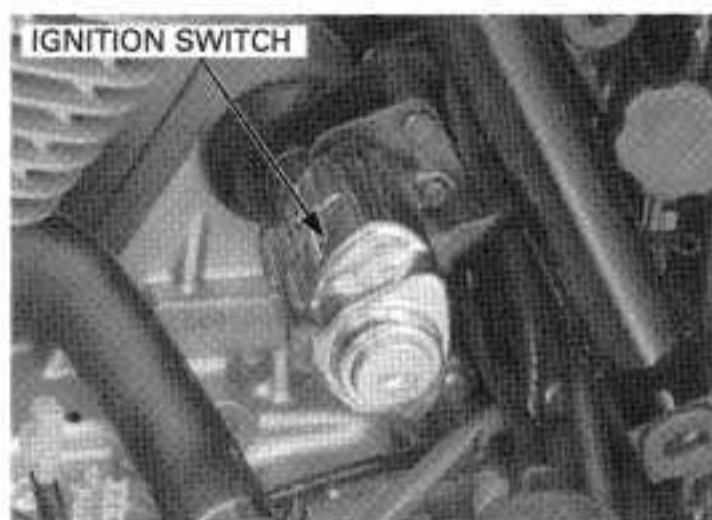

Disconnect the breather hose from the front cylinder head.



Remove the bolts and disconnect the water hose joints from the cylinder heads.

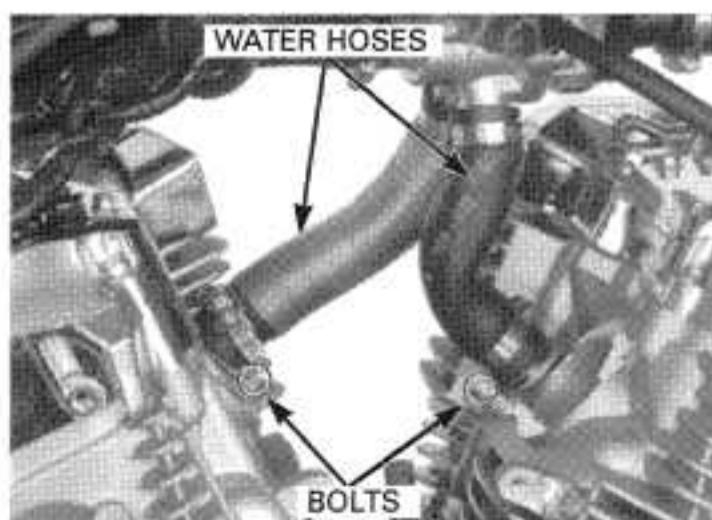

## ENGINE REMOVAL/INSTALLATION

Remove the front upper engine mounting nut and bolt.

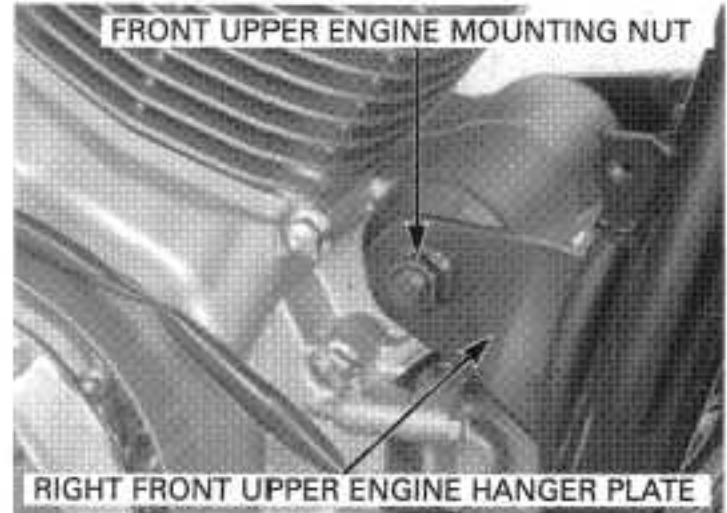

Remove the bolts and right front upper engine hanger plate.

Remove the bolts and left front upper engine hanger plate.

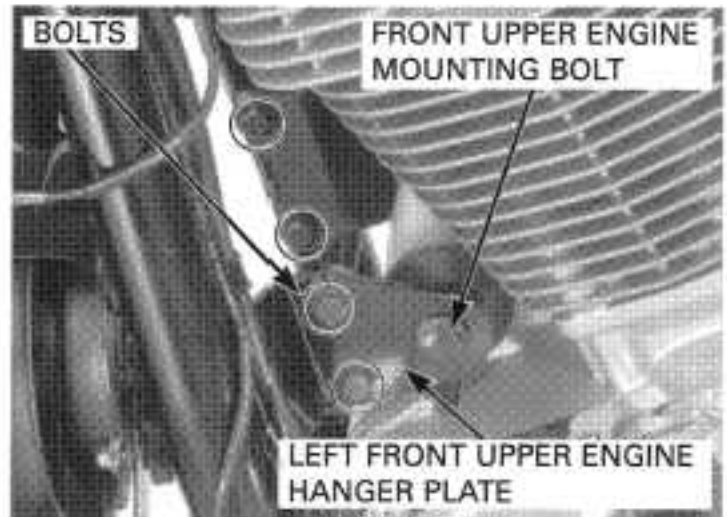

Remove the front lower engine mounting nut and bolt.  
Remove the bolt and right front lower engine hanger plate.

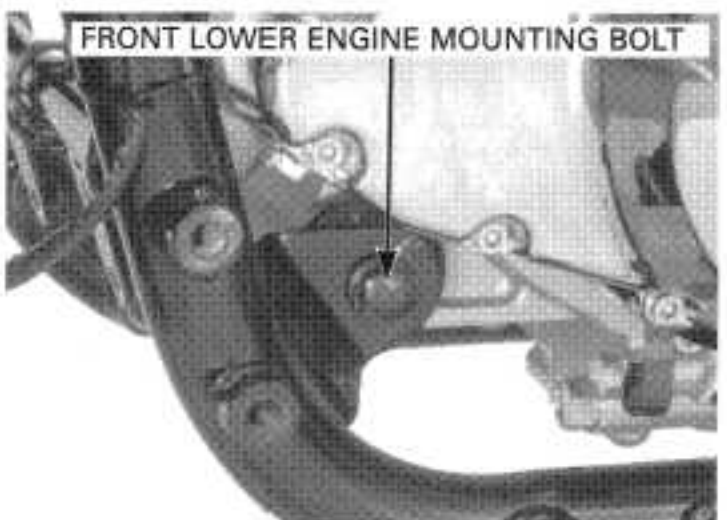
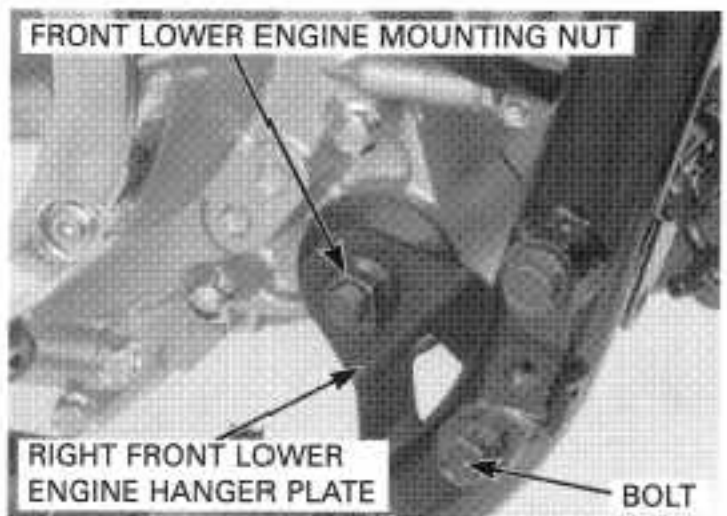



Remove the rear lower engine mounting nut and bolt. Remove the bolt and right rear lower engine hanger plate.

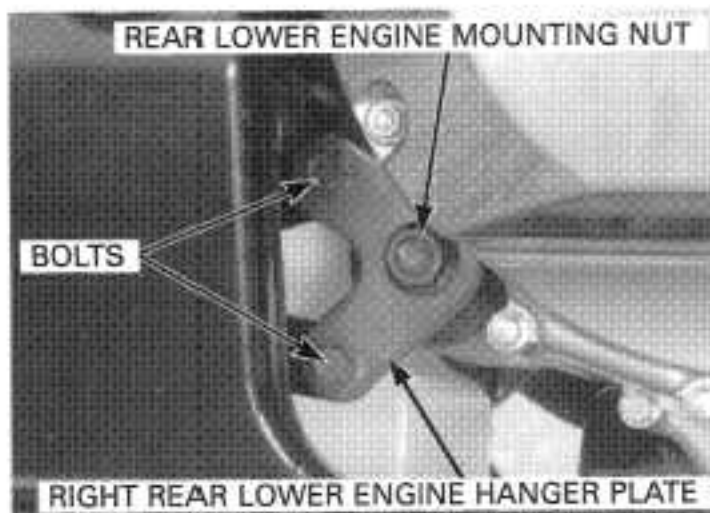

Remove the bolts and left rear lower engine hanger plate.

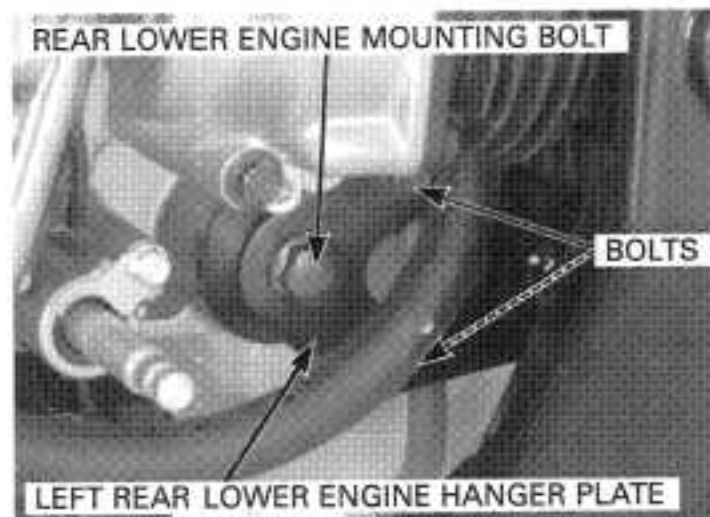

Remove the rear upper engine mounting nut and bolt. Remove the bolt and right rear upper engine hanger plate.

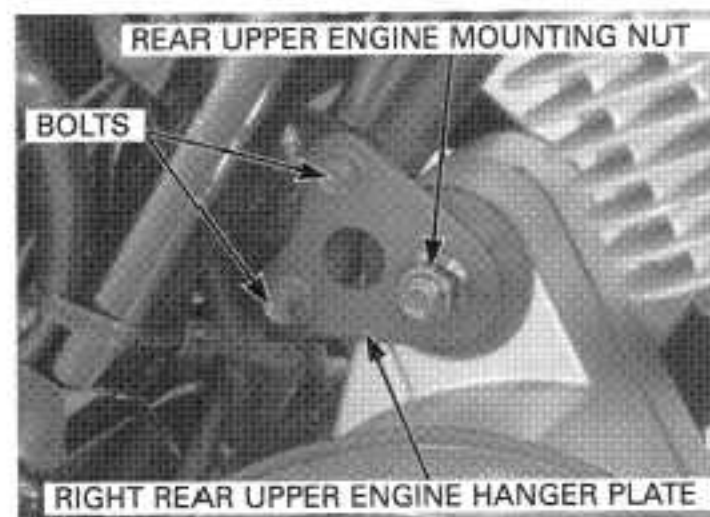

Remove the bolts and left rear upper engine hanger plate.

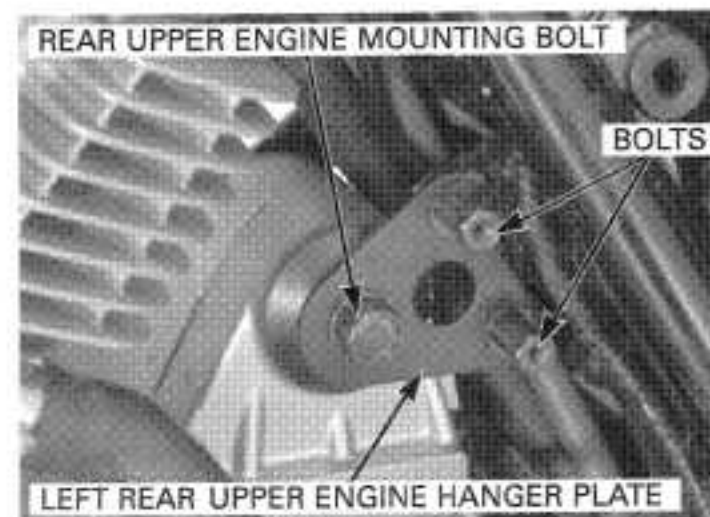



## ENGINE REMOVAL/INSTALLATION

Remove the engine from the frame by releasing the output driven gear shaft from the universal joint in the swingarm.

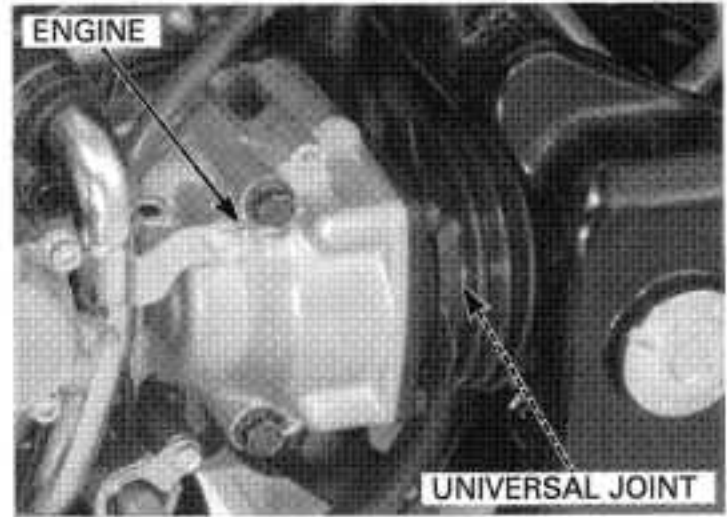

It is recommended to use two steel poles to help remove and install the engine. These poles will go through the front and rear upper engine mounts, and the engine can then be carried out of the frame. See the illustrations for pole specifications (page 7-1).

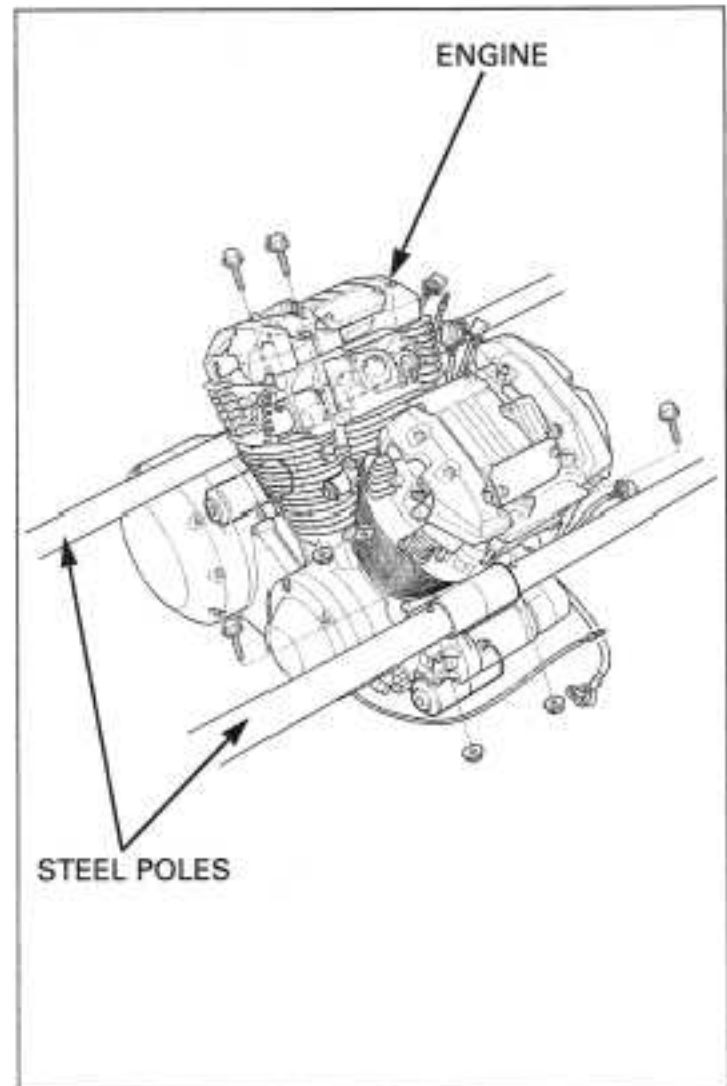

## ENGINE INSTALLATION

- Note the direction of the hanger plate bolts.
- Use a floor jack or other adjustable support to carefully maneuver the engine into place.
- Support the rear portion of the frame under the swingarm pivot to raise the rear wheel. This will allow you to rotate the rear wheel when aligning the output driven gear shaft and U-joint spline.

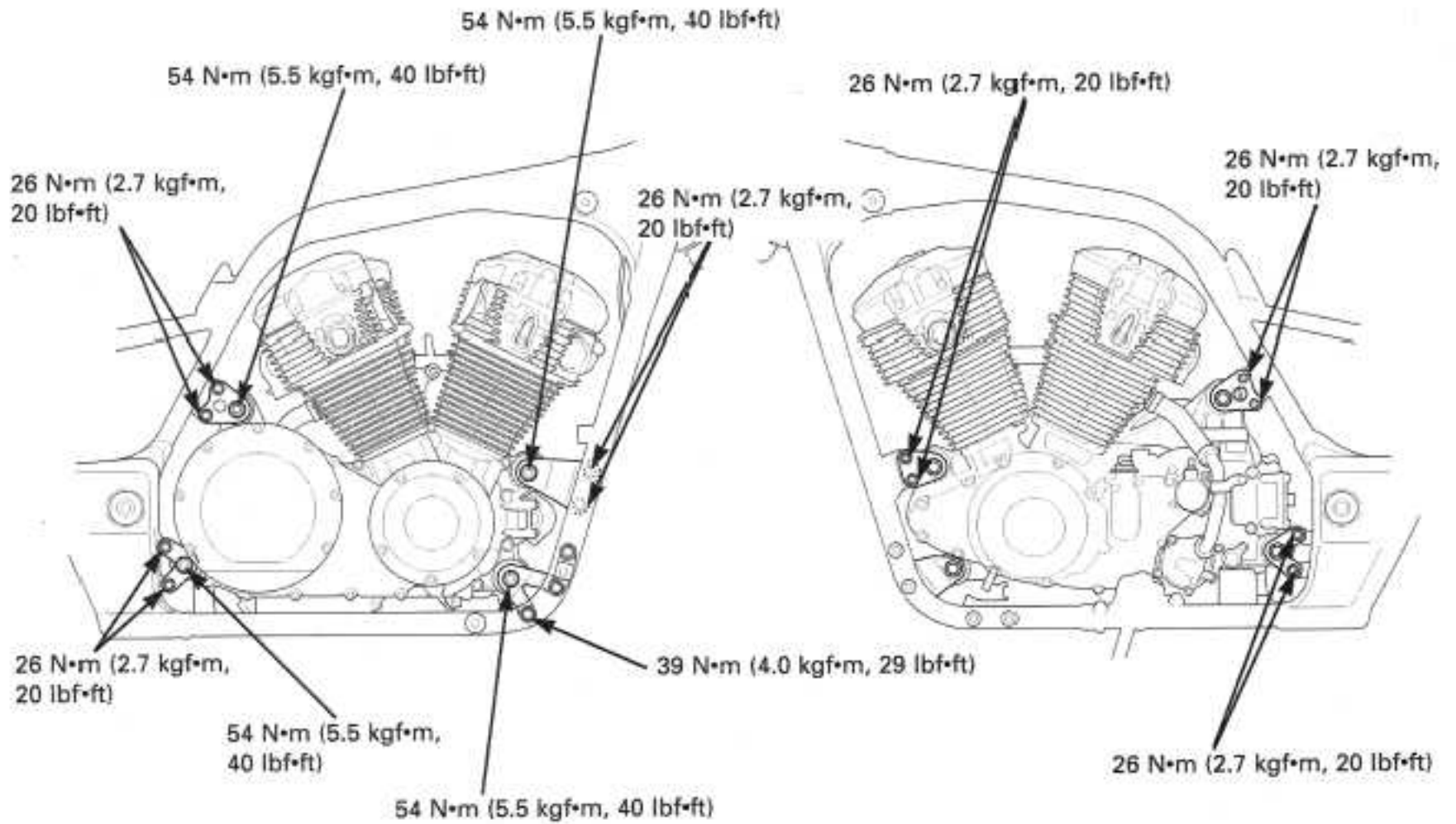

Apply molybdenum disulfide grease to the output driven gear shaft spline.  
Use a floor jack or other adjustable support to carefully maneuver the engine into the universal joint in the swingarm.

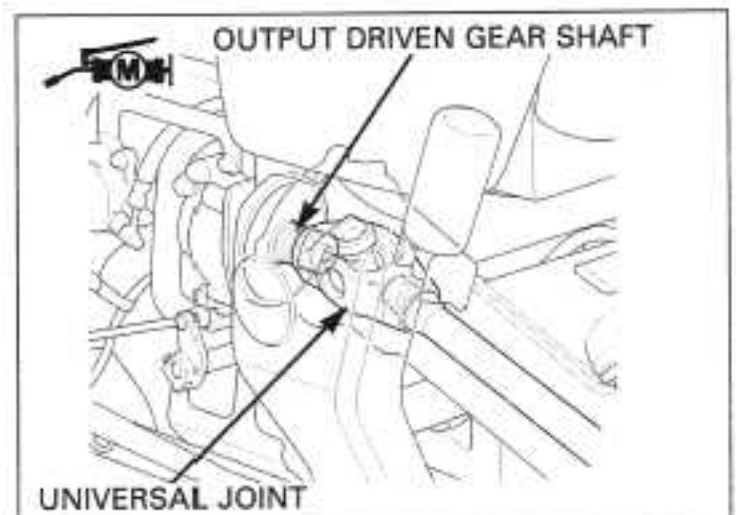

## ENGINE REMOVAL/INSTALLATION

Install the left rear upper engine hanger plate and bolts.

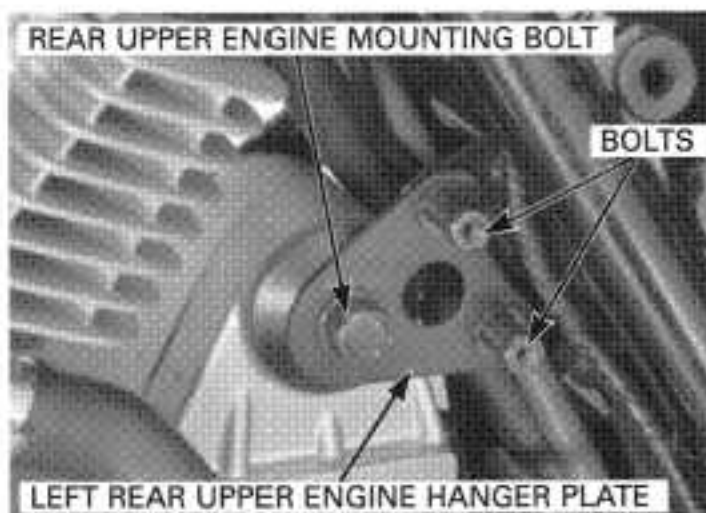

Install the right rear upper engine hanger plate and bolts.

Carefully align the bolt holes in the hanger plates and engine then insert the rear upper engine mounting bolt.

Loosely install the rear upper engine mounting nut.

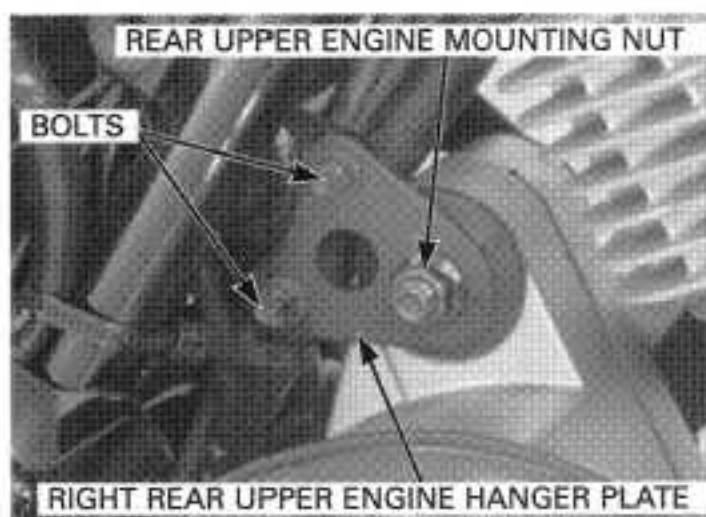

Install the left rear lower engine hanger plate and bolts.

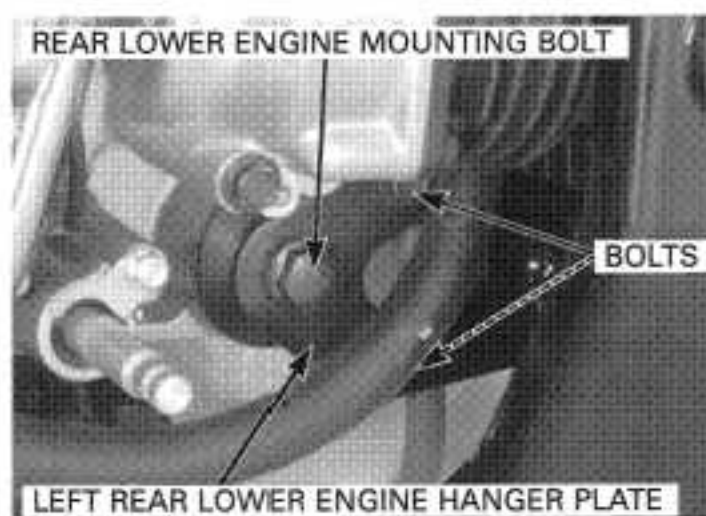

Install the right rear lower engine hanger plate and bolts.

Carefully align the bolt holes in the hanger plates and engine then insert the rear lower engine mounting bolt.

Loosely install the rear lower engine mounting nut.

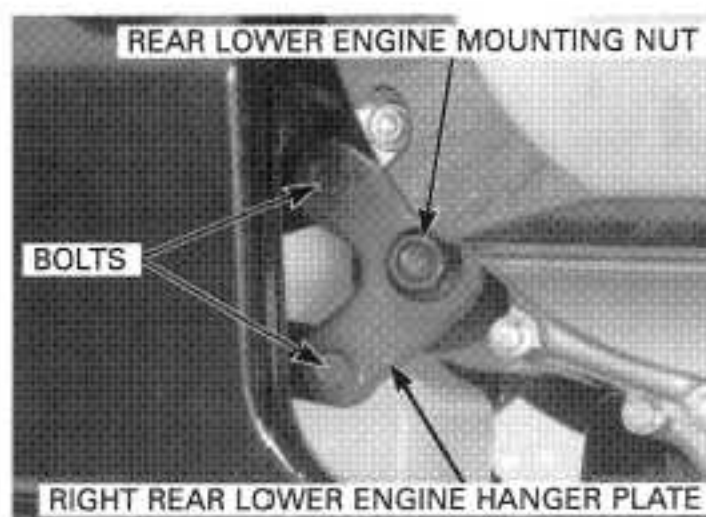

Install the right front lower engine hanger plate and bolt.

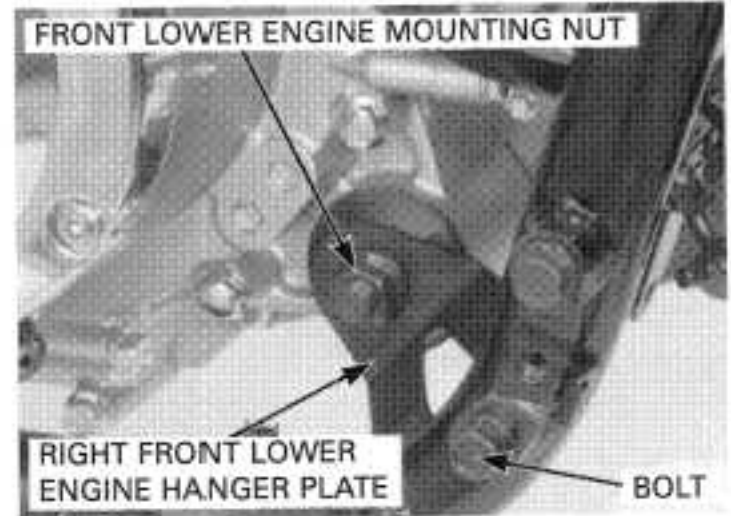

Carefully align the bolt holes in the hanger plates and engine then insert the front lower engine mounting bolt.  
Loosely install the front lower engine mounting nut.

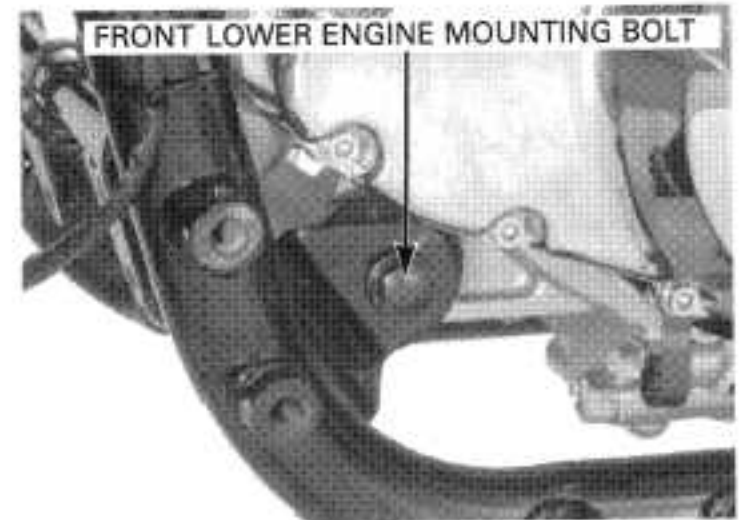

Install the left front upper engine hanger plate and bolts.

Install the right front upper engine hanger plate and bolts.

Carefully align the bolt holes in the hanger plates and engine then insert the front upper engine mounting bolt.  
Loosely install the front upper engine mounting nut.

After installing the engine, tighten all engine mounting nuts and hanger plate bolts to the specified torque.

### TORQUE:

Front upper engine mounting nut:  
54 N·m (5.5 kgf·m, 40 lbf·ft)

Front lower engine mounting nut:  
54 N·m (5.5 kgf·m, 40 lbf·ft)

Rear upper engine mounting nut:  
54 N·m (5.5 kgf·m, 40 lbf·ft)

Rear lower engine mounting nut:  
54 N·m (5.5 kgf·m, 40 lbf·ft)

Right front upper engine hanger plate bolt:  
26 N·m (2.7 kgf·m, 20 lbf·ft)

Left front lower engine hanger plate bolt:  
26 N·m (2.7 kgf·m, 20 lbf·ft)

Right front lower engine hanger plate bolt:  
39 N·m (4.0 kgf·m, 29 lbf·ft)

Rear upper engine hanger plate bolt:  
26 N·m (2.7 kgf·m, 20 lbf·ft)

Rear lower engine hanger plate bolt:  
26 N·m (2.7 kgf·m, 20 lbf·ft)

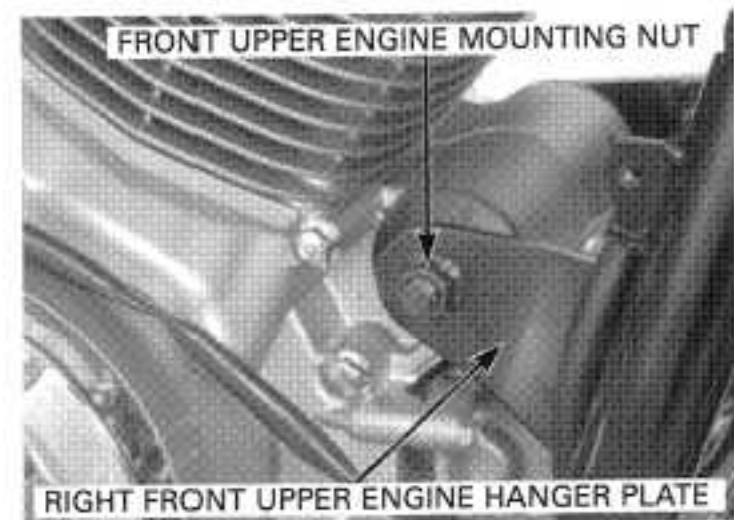
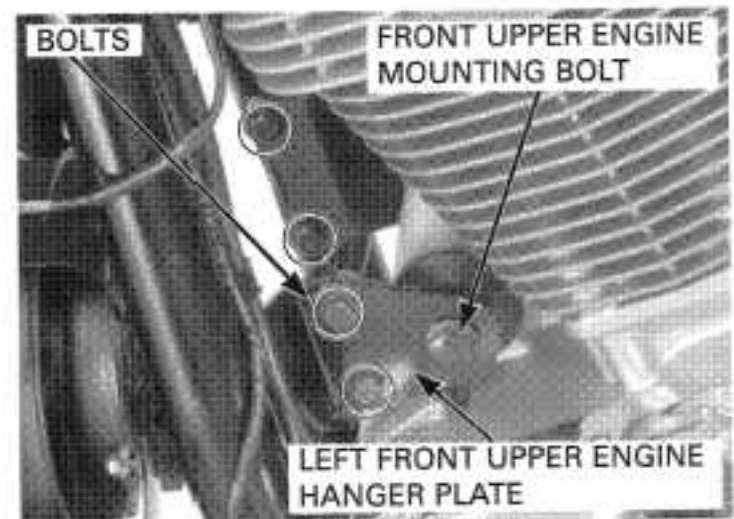



## ENGINE REMOVAL/INSTALLATION

---

Coat new O-rings with coolant and install them onto the water hose joints.

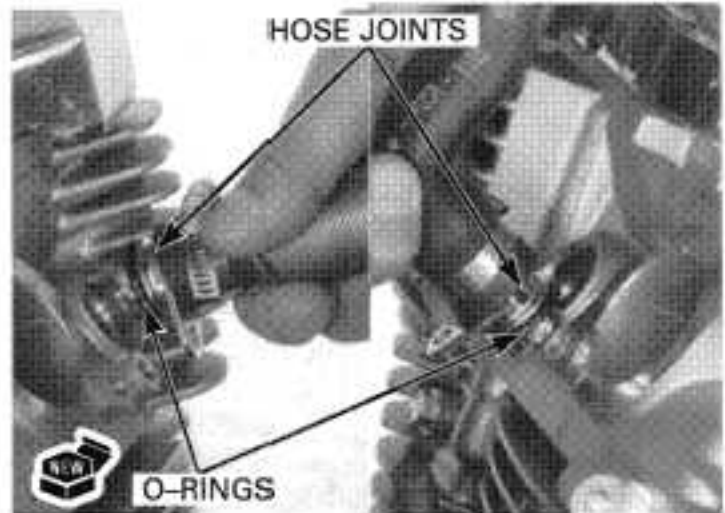

Connect the water hose joints to the cylinder heads and tighten the bolts securely.

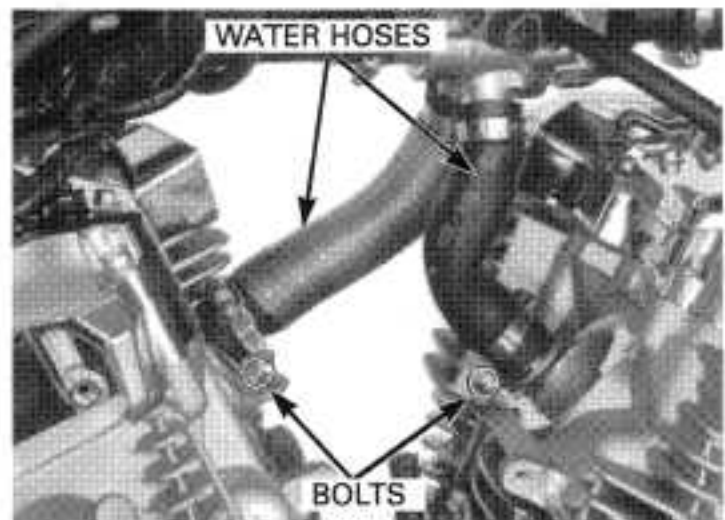

Connect the breather hose to the cylinder head.



Install the ignition switch (page 19-12).

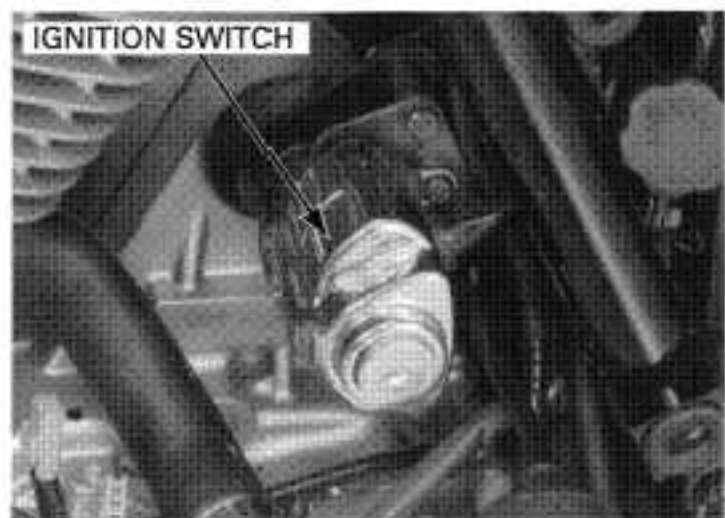



Route the starter motor cable and install it to the starter motor.  
Install and tighten the starter motor cable nut to the specified torque.

**TORQUE: 7 N·m (0.7 kgf·m, 5.1 lbf·ft)**

Install the radiator mounting bolts (page 6–9).

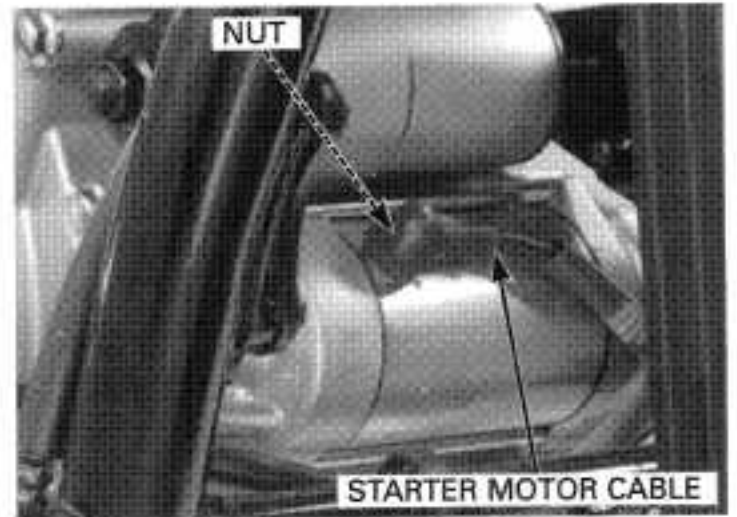

Install a new O-ring to the water pump pipe.  
Install the water pump pipe and tighten the bolts securely.

Connect the lower radiator hose and tighten the band screw securely.

Install the starter motor cable to the clamp.

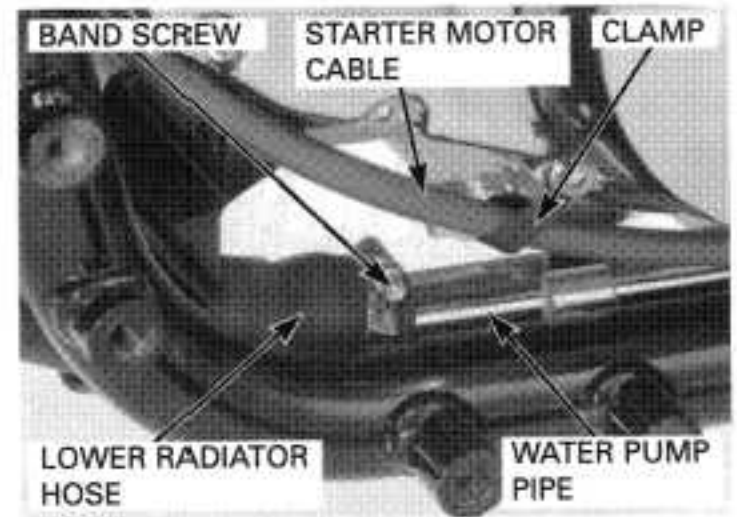

Install the starter motor cable to the clamp.

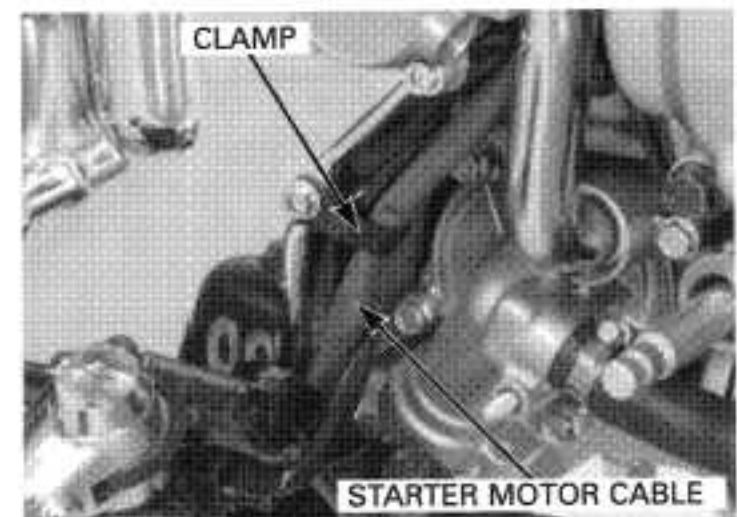

Install the left crankcase rear cover stay and tighten the bolt and nut securely.

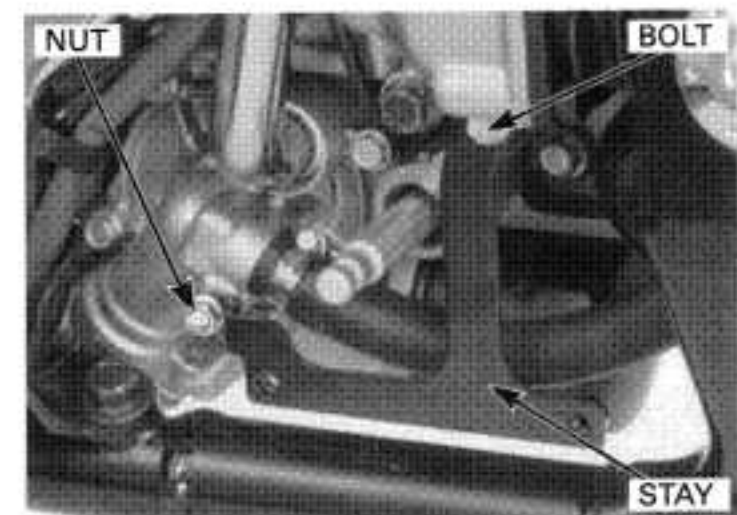

## ENGINE REMOVAL/INSTALLATION

Install the PAIR assembly.  
Connect the PAIR air hose to the front PAIR reed valve cover.

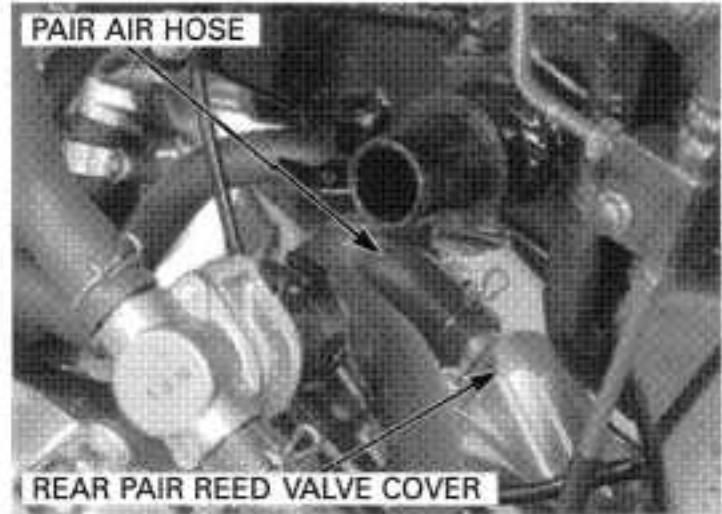

Connect the PAIR air hose to the rear PAIR reed valve cover.

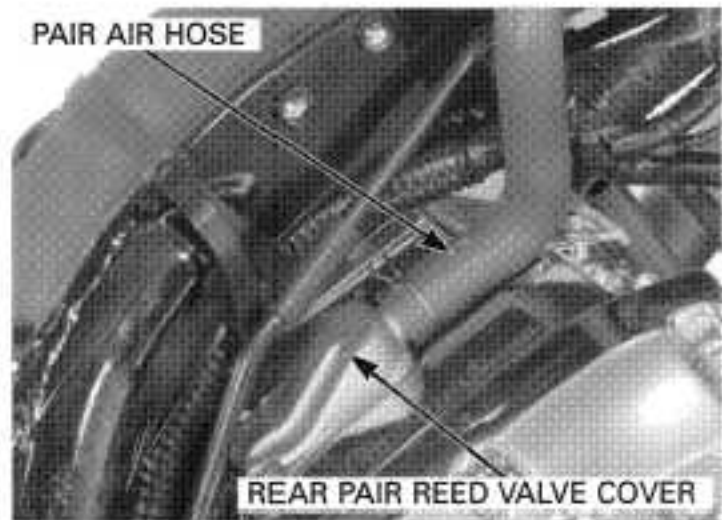

Install the PAIR solenoid valve and tighten the bolt securely.  
Connect the PAIR solenoid valve 2P connector.

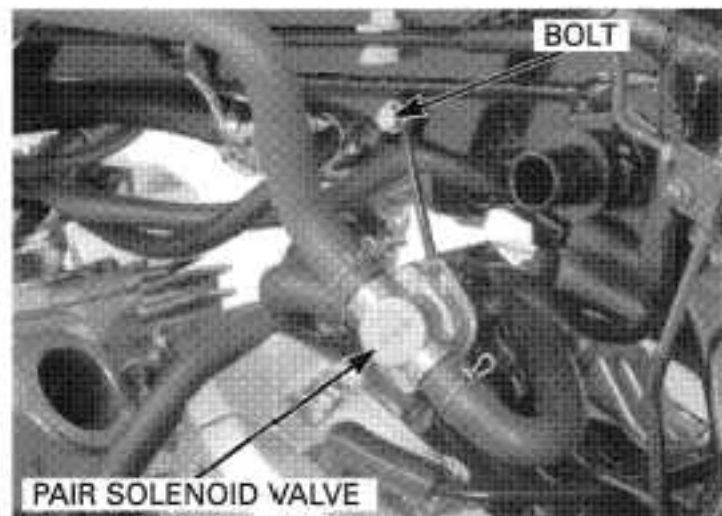

Install the intake duct control solenoid valve and accumulator.  
Install and tighten the bolt securely.  
Connect the intake duct control solenoid valve 2P connector.

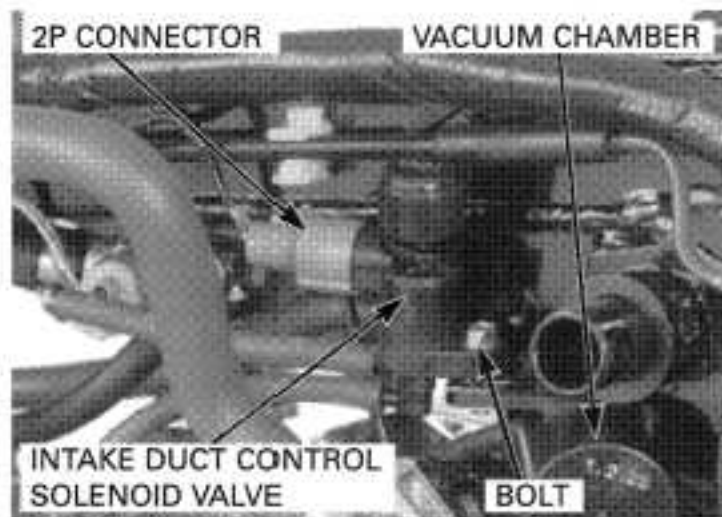

Connect the following connectors:

- Alternator 3P connector
- Ignition pulse generator 2P connector
- Neutral switch connector
- Oil pressure switch connector
- Speed sensor 3P connector
- Cam pulse generator 2P black connector
- Ground cable on the right crankcase cover

Install the following:

- Front/rear ignition coil (page 17-5)
- Throttle body (page 5-64)
- Fuel tank (page 5-56)
- Left step holder (page 16-12)
- Exhaust system (page 2-5)
- Thermostat housing bolt (page 6-12)

Pour the recommended engine oil to the proper level (page 3-14).

Fill the cooling system with the recommended coolant and bleed any air (page 6-5).

# CYLINDER HEAD/VALVE

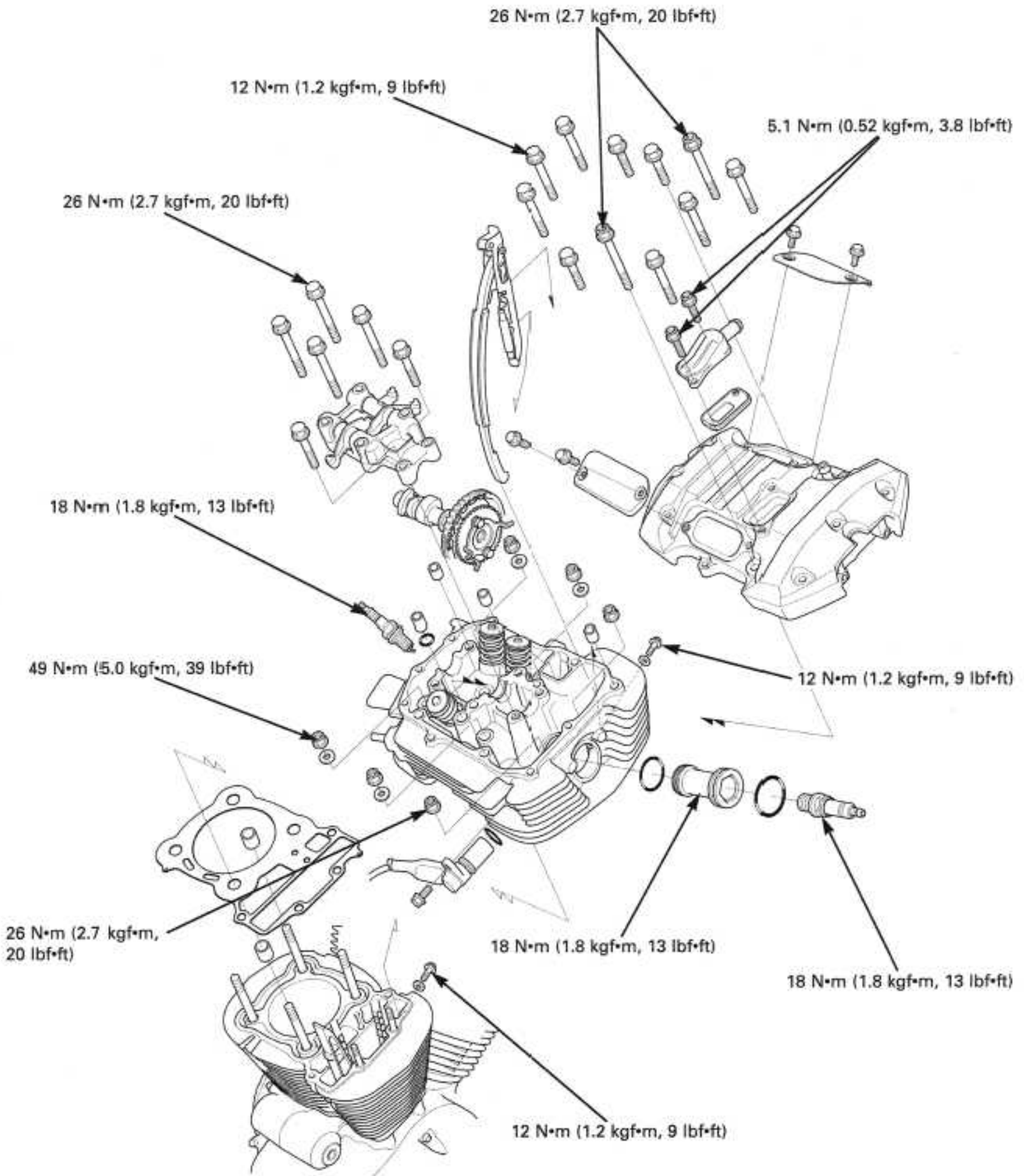

# 8. CYLINDER HEAD/VALVES

<b>SERVICE INFORMATION</b>	<b>8-1</b>	<b>VALVE GUIDE REPLACEMENT</b>	<b>8-13</b>
<b>TROUBLESHOOTING</b>	<b>8-2</b>	<b>VALVE SEAT INSPECTION/REFACING</b>	<b>8-14</b>
<b>CYLINDER COMPRESSION</b>	<b>8-3</b>	<b>CYLINDER HEAD ASSEMBLY</b>	<b>8-17</b>
<b>CYLINDER HEAD COVER REMOVAL</b>	<b>8-3</b>	<b>CYLINDER HEAD INSTALLATION</b>	<b>8-19</b>
<b>CAMSHAFT REMOVAL</b>	<b>8-4</b>	<b>CAMSHAFT INSTALLATION</b>	<b>8-20</b>
<b>CYLINDER HEAD REMOVAL</b>	<b>8-9</b>	<b>CYLINDER HEAD COVER INSTALLATION</b>	<b>8-25</b>
<b>CYLINDER HEAD DISASSEMBLY</b>	<b>8-10</b>		

## SERVICE INFORMATION

### GENERAL

- This section covers service of the cylinder head, valves, camshafts and rocker arms. To service these parts, the engine must be removed from the frame.
- When disassembling, mark and store the disassembled parts to ensure that they are reinstalled in their original locations.
- Clean all disassembled parts with cleaning solvent and dry them with compressed air before inspection.
- Camshaft and rocker arm lubricating oil is fed through oil passages in the cylinder head and head cover. Clean the oil passages before assembling the cylinder head and head cover.
- Pour clean engine oil into the oil pockets in the cylinder head during assembly to lubricate the camshaft.
- Be careful not to damage the mating surfaces when removing the head cover and cylinder head.

8

### SPECIFICATION

Unit: mm (in)

ITEM		STANDARD	SERVICE LIMIT
Cylinder compression		657 kPa (6.7 kgf/cm <sup>2</sup> , 95 psi) at 320 rpm	—
Valve clearance		IN 0.13 ± 0.02 (0.005 ± 0.001)	—
		EX 0.32 ± 0.02 (0.013 ± 0.001)	—
Camshaft	Cam lobe height	IN 39.953 – 40.033 (1.5729 – 1.5761)	39.92 (1.572)
		EX 39.423 – 39.503 (1.5521 – 1.5552)	39.40 (1.551)
	Runout	—	0.05 (0.002)
Oil clearance		0.040 – 0.101 (0.0016 – 0.0040)	0.12 (0.005)
Rocker arm, rocker arm shaft	Rocker arm shaft O.D.	IN/EX 13.976 – 13.994 (0.5502 – 0.5509)	13.92 (0.548)
	Rocker arm I.D.	IN/EX 14.006 – 14.024 (0.5514 – 0.5521)	14.05 (0.553)
	Rocker arm-to-rocker arm shaft clearance	0.012 – 0.048 (0.0005 – 0.0019)	0.14 (0.006)
Valve, valve guide	Valve stem O.D.	IN 6.575 – 6.590 (0.2589 – 0.2594)	6.57 (0.259)
		EX 7.955 – 7.970 (0.3132 – 0.3138)	7.94 (0.313)
	Valve guide I.D.	IN 6.600 – 6.615 (0.2598 – 0.2604)	6.635 (0.2612)
		EX 8.000 – 8.015 (0.3150 – 0.3156)	8.055 (0.3171)
	Stem-to-guide clearance	IN 0.010 – 0.040 (0.0039 – 0.0016)	0.08 (0.003)
		EX 0.030 – 0.060 (0.0012 – 0.0024)	0.12 (0.005)
	Valve guide projection above cylinder head	IN 16.4 – 16.6 (0.646 – 0.654)	—
		EX 17.7 – 17.9 (0.697 – 0.705)	—
Valve seat width	IN 1.10 – 1.30 (0.043 – 0.051)	1.70 (0.669)	
	EX 1.40 – 1.60 (0.055 – 0.063)	2.00 (0.079)	



## CYLINDER HEAD/VALVES

ITEM		STANDARD		SERVICE LIMIT
Valve, valve guide	Valve spring free length	IN	43.5 (1.71)	41.9 (1.65)
		EX	44.2 (1.74)	42.4 (1.67)
Cylinder head warpage		—		0.10 (0.004)

## TORQUE VALUES

Spark plug	18 N•m (1.8 kgf•m, 13 lbf•ft)	
Spark plug sleeve	18 N•m (1.8 kgf•m, 13 lbf•ft)	Apply oil to the threads and flange surface.
Reed valve cover bolt	5.1 N•m (0.52 kgf•m, 3.8 lbf•ft)	
Cylinder head cover bolt (8 mm)	26 N•m (2.7 kgf•m, 20 lbf•ft)	
(6 mm)	12 N•m (1.2 kgf•m, 9 lbf•ft)	
Cylinder head nut (10 mm)	49 N•m (5.0 kgf•m, 39 lbf•ft)	Apply oil to the threads and flange surface.
(8 mm)	26 N•m (2.7 kgf•m, 20 lbf•ft)	Apply oil to the threads and flange surface.
Camshaft holder bolt	26 N•m (2.7 kgf•m, 20 lbf•ft)	Apply oil to the threads and flange surface.
Cam sprocket bolt	23 N•m (2.3 kgf•m, 17 lbf•ft)	
Valve adjusting screw lock nut	22 N•m (2.2 kgf•m, 16 lbf•ft)	
Cam chain tensioner bolt	12 N•m (1.2 kgf•m, 9 lbf•ft)	

## TOOLS

Valve guide driver, 6.6 mm	07942-6570100	
Valve spring compressor	07757-0010000	
Valve seat cutters		Equivalent commercially available in U.S.A.
Seat cutter, 40 mm (45° IN)	07780-0010500	
Seat cutter, 46 mm (45° EX)	07780-0011200	
Flat cutter, 38.5 mm (32° IN)	07780-0012400	
Flat cutter, 50 mm (32° EX)	07780-0013600	
Interior cutter, 34 mm (60° IN)	07780-0014700	
Interior cutter, 45 mm (60° EX)	07780-0014800	
Cutter holder, 6.6 mm	07781-0010202 or 07942-ZE2000D (U.S.A. only)	
Holder attachment	07930-KA50100	
Valve guide reamer, 6.6 mm	07984-657010D	
Valve guide driver, 8 mm	07ZMD-MCHA100	
Cutter holder, 8 mm	07ZMH-MCHC100 equivalent commercially available in U.S.A.	
Valve guide reamer, 8 mm	07ZMH-MCHA200	

## TROUBLESHOOTING

Engine top-end problems usually affect engine performance. These can be diagnosed by a compression test, or by tracing top-end noise with a sounding rod or stethoscope. (See page 8-3 engine compression testing.)

### Compression too low, hard starting or poor performance at low speed

- Valves
  - Incorrect valve adjustment
  - Burned or bent valves
  - Broken valve spring
  - Uneven valve seating
  - Valve stuck open
- Cylinder head
  - Leaking or damaged cylinder head gasket
  - Warped or cracked cylinder head
  - Loose spark plug
- Cylinder/piston (section 9)

### Compression too high

- Excessive carbon build-up on piston or combustion chamber

### Excessive smoke

- Worn valve stem or valve guide
- Damaged stem seal
- Cylinder/piston (section 9)

### Excessive noise

- Incorrect valve clearance
- Sticking valve or broken valve spring
- Worn or damaged camshaft
- Worn or damaged rocker arm and/or shaft
- Worn or damaged cam sprocket teeth
- Loose or worn cam chain
- Worn or damaged cam chain tensioner

## CYLINDER COMPRESSION

Warm up the engine to normal operating temperature.

Open and support the rear end of the fuel tank (page 3-4).

Disconnect the fuel pump 3P black connector.

*The cylinder compression pressure specification is low because each camshaft has a decompression device installed.*

Stop the engine, disconnect the spark plug caps and remove one spark plug at a time.

Shift the transmission into neutral.

Install the compression gauge into the spark plug hole.

Open the throttle all the way and crank the engine with the starter motor.

Crank the engine until the gauge reading stops rising. The maximum reading is usually reached within 4-7 seconds.

### COMPRESSION PRESSURE:

**657 kPa (6.7 kgf/cm<sup>2</sup>, 95 psi) – at 320 rpm**

If the compression is high, it indicates that carbon deposits have accumulated on the combustion chamber and/or the piston crown.

If compression is low, pour 3 – 5 cc (0.1 – 0.2 oz) of clean engine oil into the cylinder through the spark plug hole and recheck the cylinder, piston and piston rings.

If compression is the same as the previous value, check the valves for leakage.

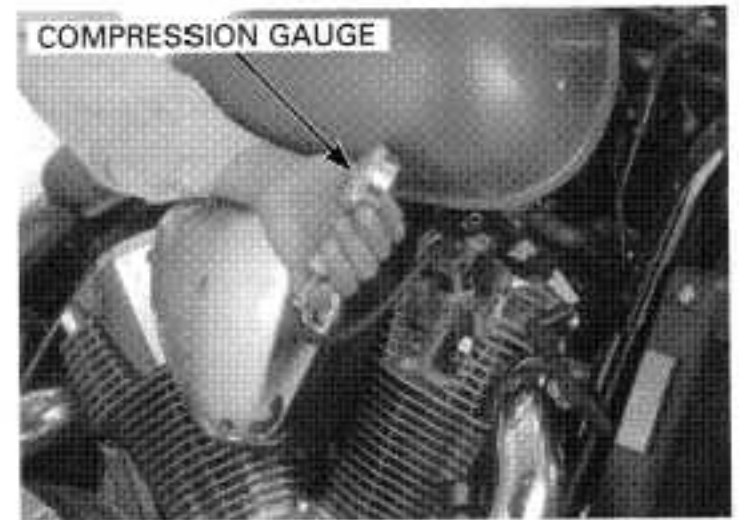
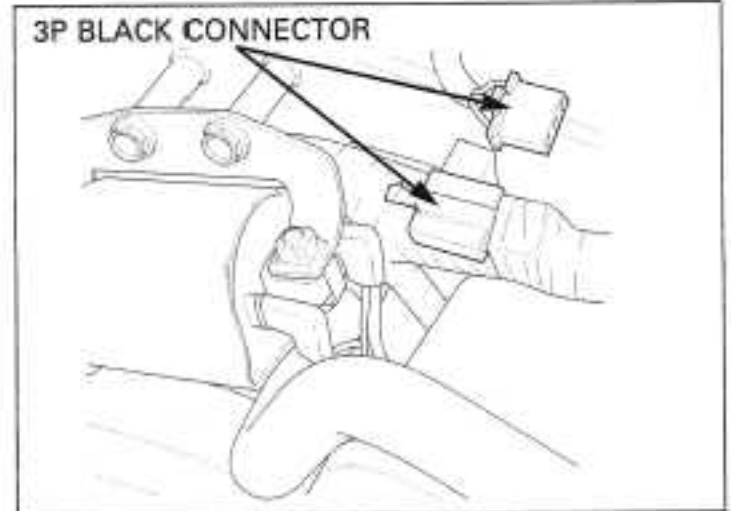

## CYLINDER HEAD COVER REMOVAL

*The front cylinder head cover can be removed with the engine in the frame.*

*Be careful not to damage the cylinder head cover mating surface.*

Remove the engine from the frame (section 7).  
Remove the PAIR check reed valves (page 5-82).  
Remove the valve adjusting covers (page 3-9).

Remove the 8 mm bolts and 10 mm bolts.  
Remove the cylinder head cover.

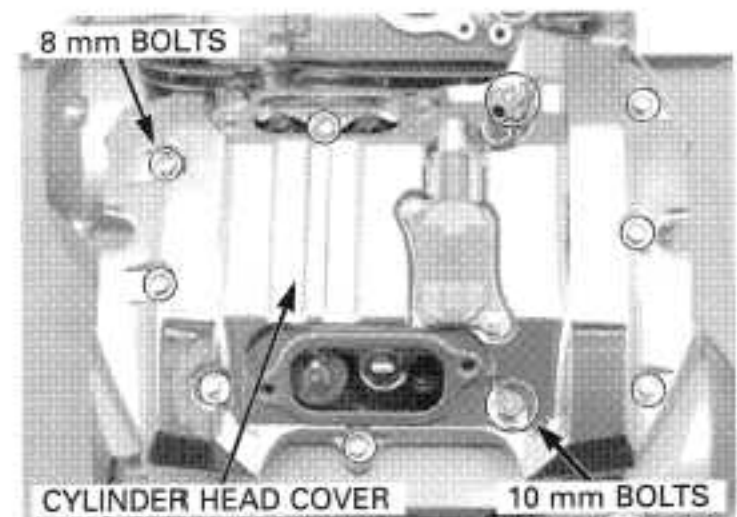

## CYLINDER HEAD/VALVES

Remove the dowel pins and O-ring.

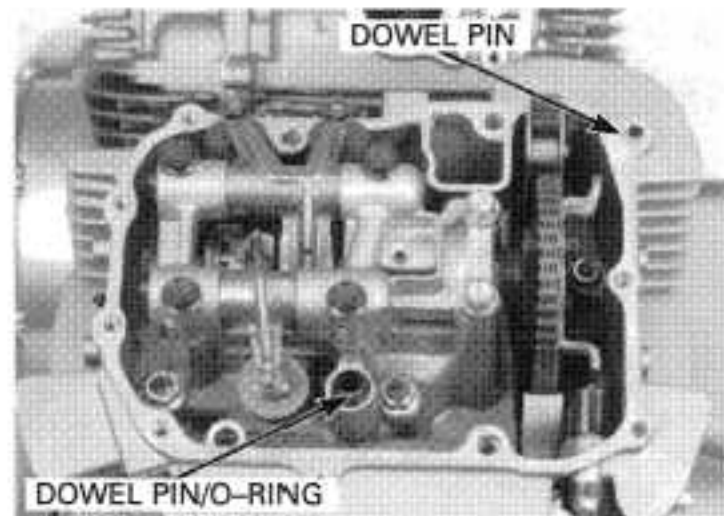

## CAMSHAFT REMOVAL

Remove the socket bolts, timing cover and the crankshaft hole cap (page 3-8).  
Remove the spark plugs (page 3-6).

Remove the spark plug sleeve on the cam chain side using the holder attachment.

**TOOL:**

Holder attachment

07930-KA50100

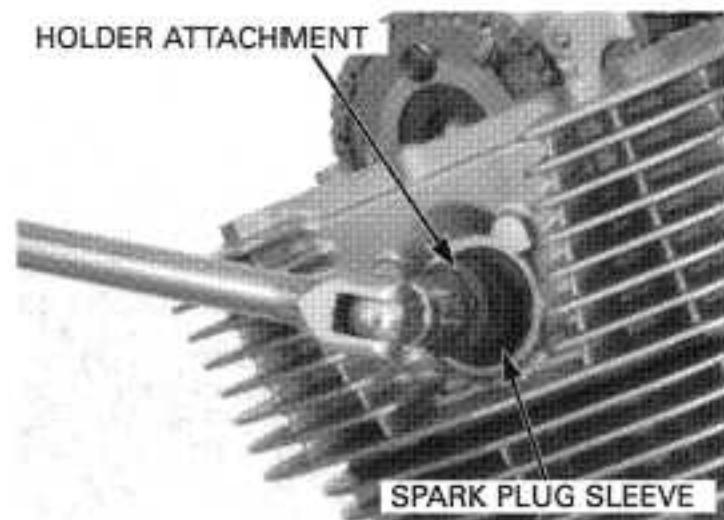

Front cylinder:

Remove the front cylinder head cover (page 8-3).

Rotate the crankshaft clockwise and align the "FT" mark on the primary drive gear with the index mark on the right crankcase cover.

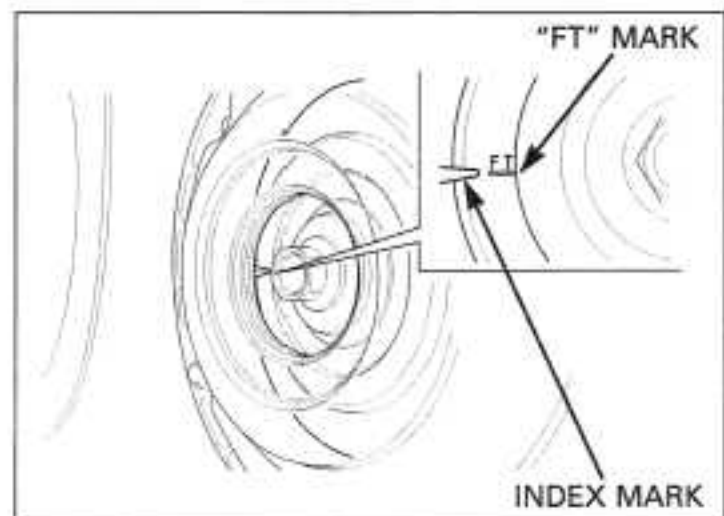

Check that the index lines on the front cylinder camshaft are flush with the cylinder head surface and "F" and "R" marks facing as shown (TDC).

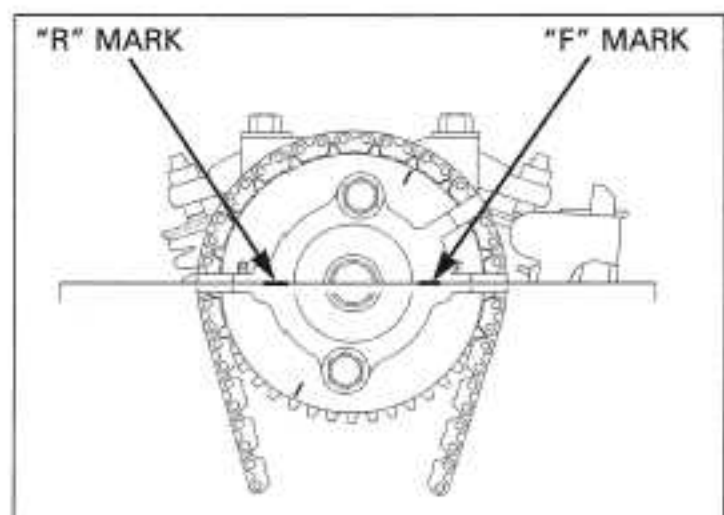

### Rear cylinder:

Remove the rear cylinder head cover (page 8-3).

Rotate the crankshaft clockwise and align the "RT" mark on the primary drive gear with the index mark on the right crankcase cover.

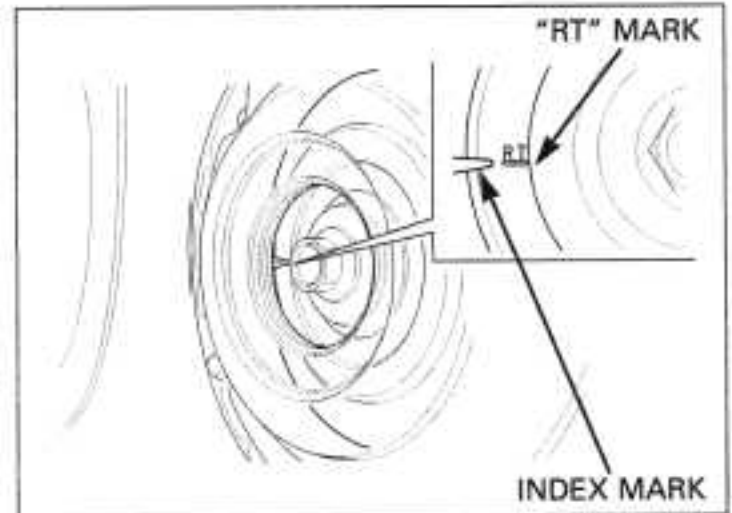

Check that the index lines on the rear cylinder camshaft are flush with the cylinder head surface and "F" and "R" marks facing as shown (TDC).

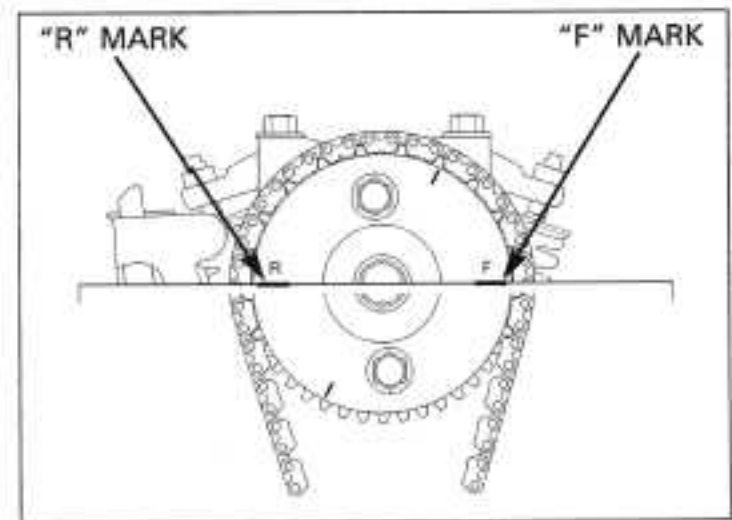

Before releasing the cam chain tensioner, measure the distance the cam chain tensioner projects above the bracket as shown.

Replace the cam chain with a new one if the projection exceeds 9.0 mm (0.35 in).

To replace the cam chain, remove the following parts:

- Cam sprocket (page 8-21)
- Front cylinder: flywheel (section 18)
- Rear cylinder: primary drive gear (section 10)

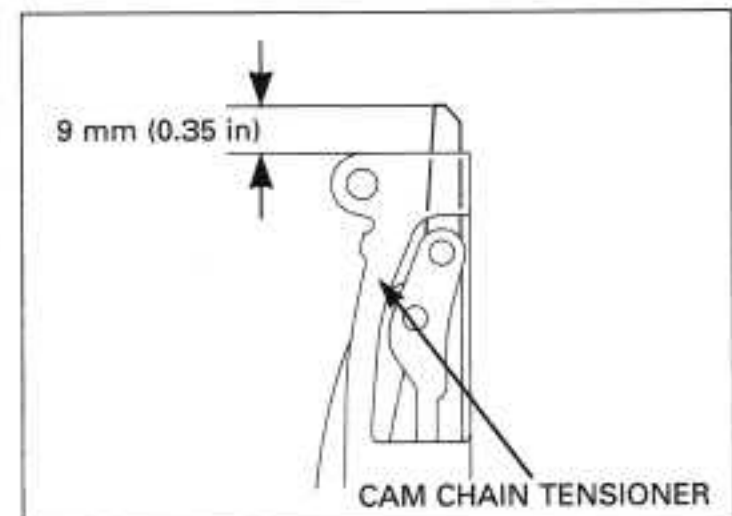

Release the tensioner by pulling wedge A straight up while holding wedge B down, then secure wedge A with a 2 mm pin as shown.

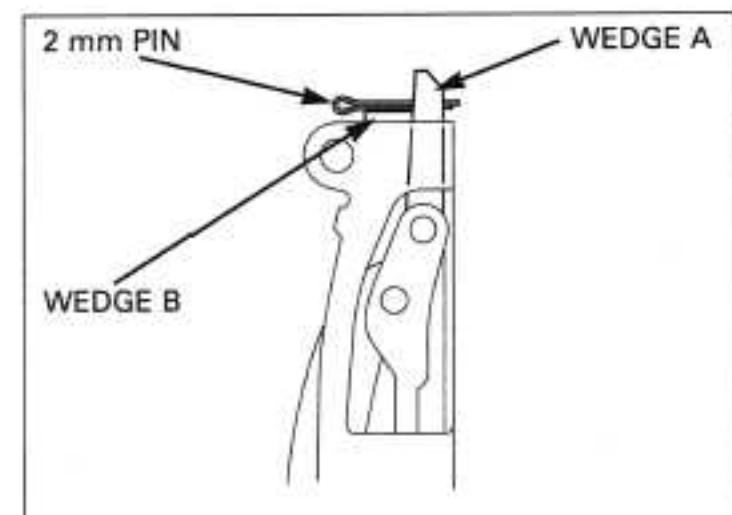



## CYLINDER HEAD/VALVES

*Be careful not to let the cam sprocket bolts fall into the crankcase.*

If you plan to replace the camshaft and/or cam sprocket, remove the cam sprocket bolts as follow:

- Remove the cam sprocket bolt.
- Rotate the crankshaft clockwise one turn (360°) and remove the other cam sprocket bolt.
- Remove the cam sprocket from the camshaft flange surface.

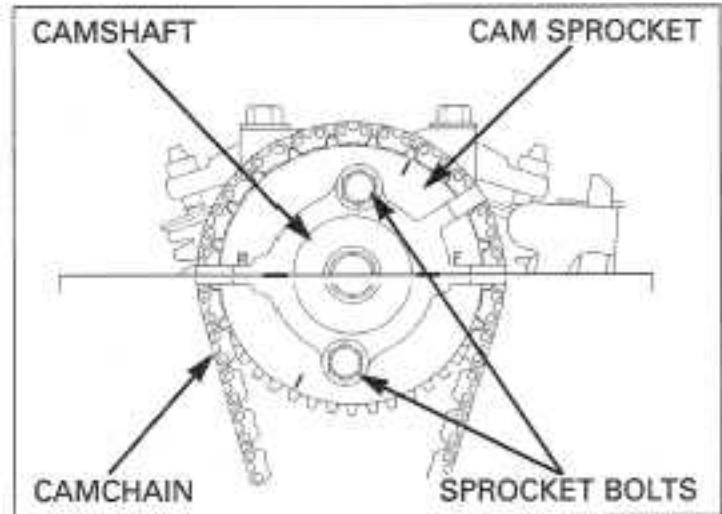

Remove the camshaft holder bolts and camshaft holder assembly.

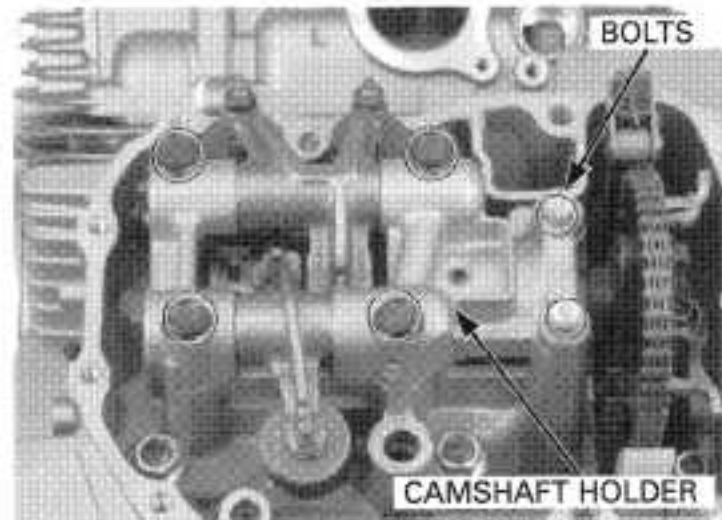

Remove the dowel pins.

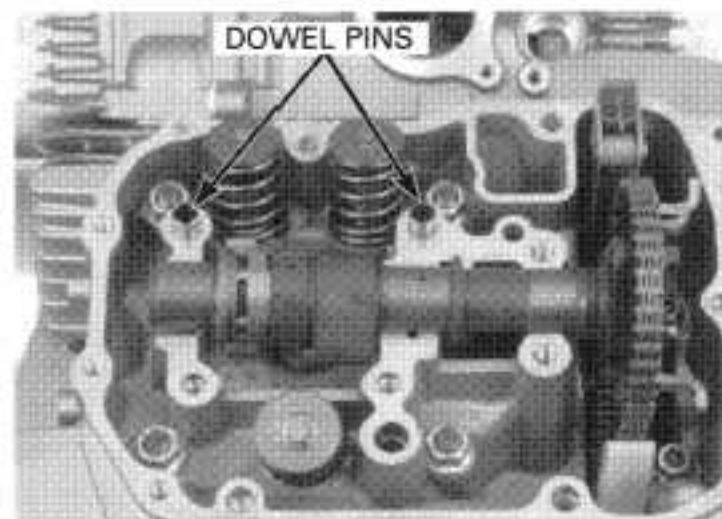

Remove the camshaft.

Attach a piece of wire to the cam chain to prevent it from falling into the crankcase and remove the cam sprocket from the cam chain.

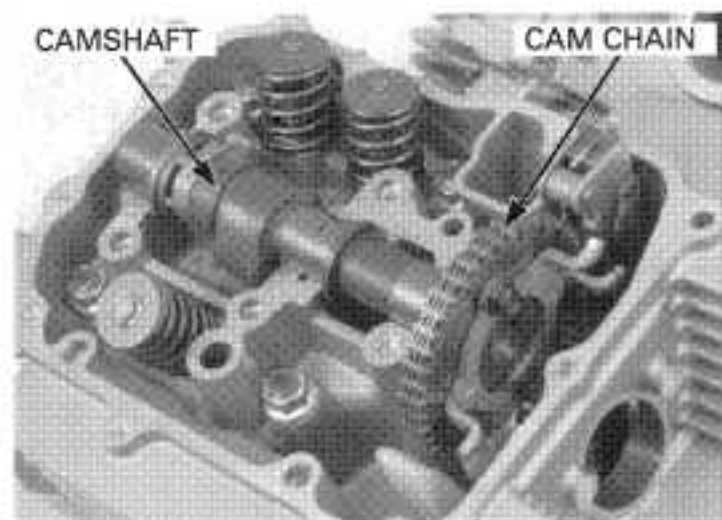



**CAMSHAFT HOLDER DISASSEMBLY**

Remove the exhaust rocker arm shaft and exhaust rocker arm from the camshaft holder.

Remove the intake rocker arm shaft and intake rocker arm from the camshaft holder.

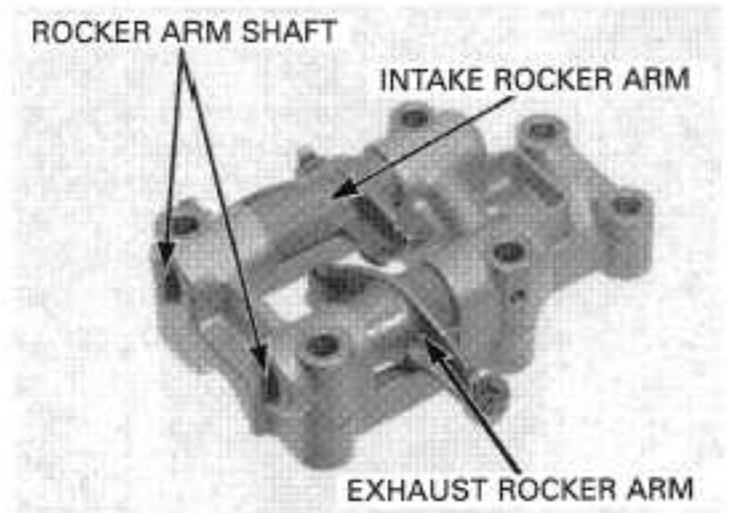

**INSPECTION**

**CAMSHAFT JOURNAL**

Inspect the camshaft journal surfaces of the holder for scoring or evidence of insufficient lubrication.

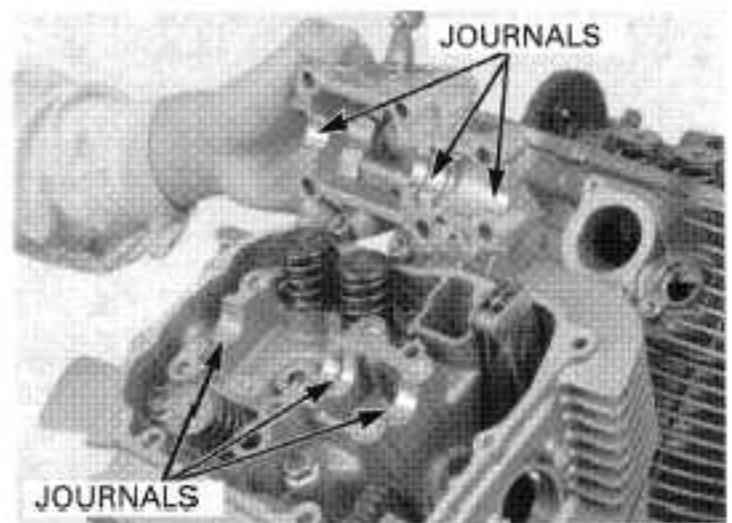

Measure the O.D. of each camshaft journal using a micrometer.

**SERVICE LIMITS: A/B: 23.91 mm (0.941 in)**

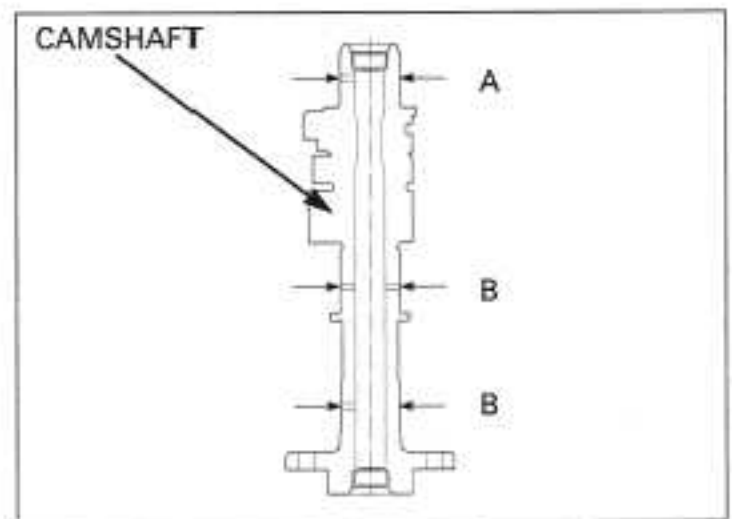

**CAMSHAFT RUNOUT**

Support both ends of the camshaft with V-blocks and check the camshaft runout with a dial indicator.

**SERVICE LIMIT: 0.05 mm (0.002 in)**

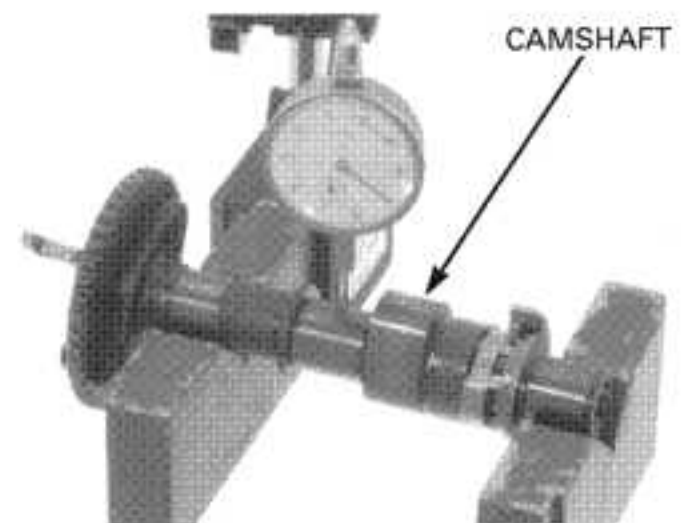

## CYLINDER HEAD/VALVES

### CAM LOBE HEIGHT

Measure the height of each cam lobe using a micrometer.

**SERVICE LIMITS:** IN: 39.92 mm (1.572 in)  
EX: 39.40 mm (1.551 in)



### DECOMPRESSOR CAM

Inspect the decompressor cam surfaces for scoring or evidence of insufficient lubrication.

Check the decompressor cam for smooth operation.



### CAMSHAFT OIL CLEARANCE

*Do not hook the cam chain suspension wire against the head cover mating surface.*

Suspend the cam chain attaching wire through the spark plug sleeve hole and hook it.

Clean off any oil from the journals of the camshaft holder, head and camshaft.

Put the camshaft onto the cylinder head and lay a strip of plastigauge lengthwise on top of each camshaft journal.

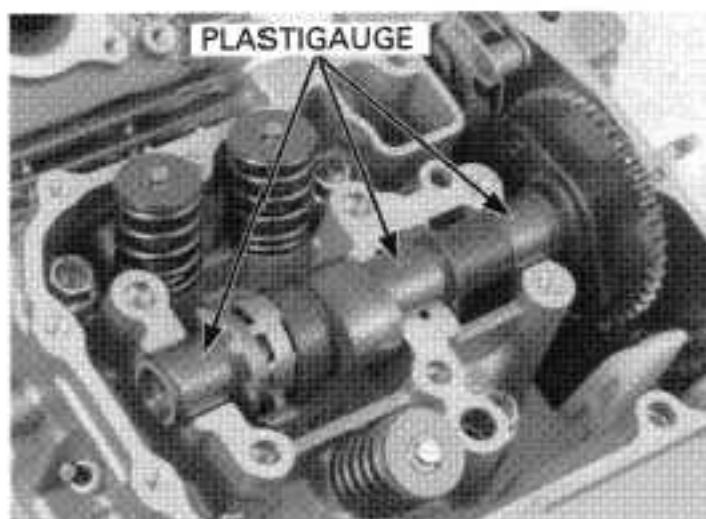

*Do not rotate the camshaft during inspection.*

Apply engine oil to the threads and seating surfaces of the camshaft holder bolts.

Install the camshaft holder and tighten the bolts in a crisscross pattern in two or three steps.

**TORQUE: 26 N·m (2.7 kgf·m, 20 lbf·ft)**

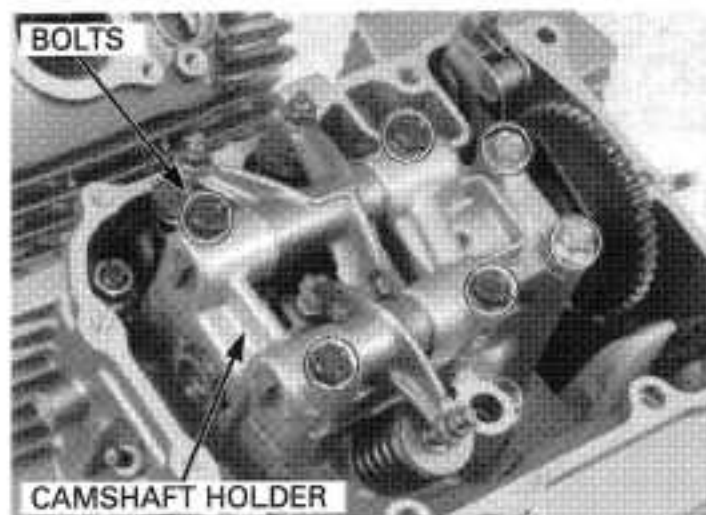

Remove the camshaft holder and measure the width of each plastigauge at its widest point on the camshaft to determine the oil clearance.

**SERVICE LIMITS: 0.12 mm (0.005 in)**

When the service limits are exceeded, replace the camshaft and recheck the oil clearance. Replace the cylinder head and camshaft holder as a set if the clearance still exceeds the service limit.



**ROCKER ARM, ROCKER ARM SHAFT**

Inspect the sliding surface of the rocker arms for wear or damage where they contact the camshaft, or for clogged oil holes.

Inspect the contact surface of the valve adjuster screw for wear or damage.

Measure the I.D. of each rocker arm.

**SERVICE LIMIT: 14.05 mm (0.553 in)**

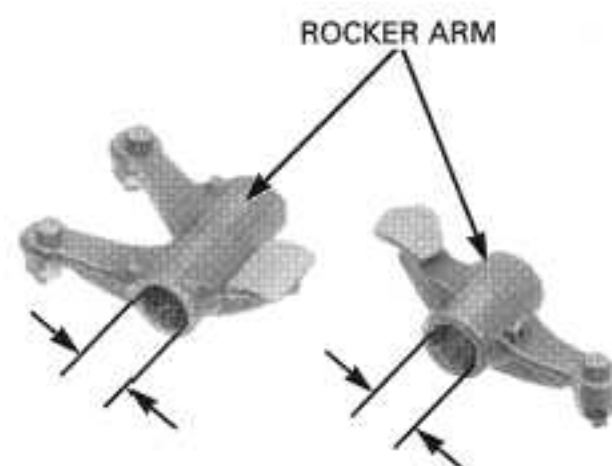

Measure the O.D. of each rocker arm shaft.

**SERVICE LIMIT: 13.92 mm (0.548 in)**

Inspect the shaft for wear or damage and calculate the shaft to rocker arm clearance.

**SERVICE LIMIT: 0.14 mm (0.006 in)**

Replace the rocker arm and/or shaft if necessary.

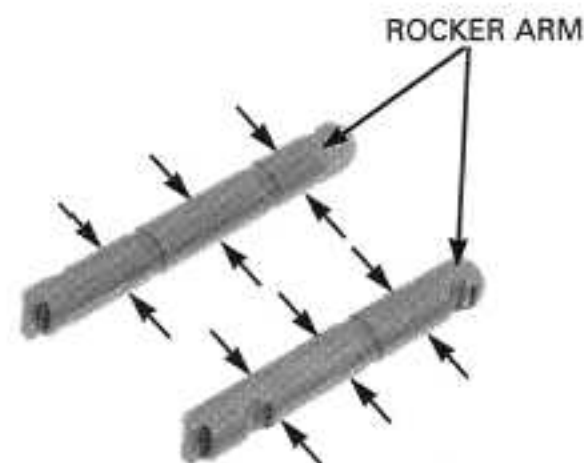

**CYLINDER HEAD REMOVAL**

Remove the camshaft (page 8-4).

Remove the cam chain tensioner bolts, sealing washers and cam chain tensioner.



## CYLINDER HEAD/VALVES

Loosen the cylinder head nuts in a crisscross pattern in two or three steps, and remove them.  
Remove the washers  
Remove the cylinder head.

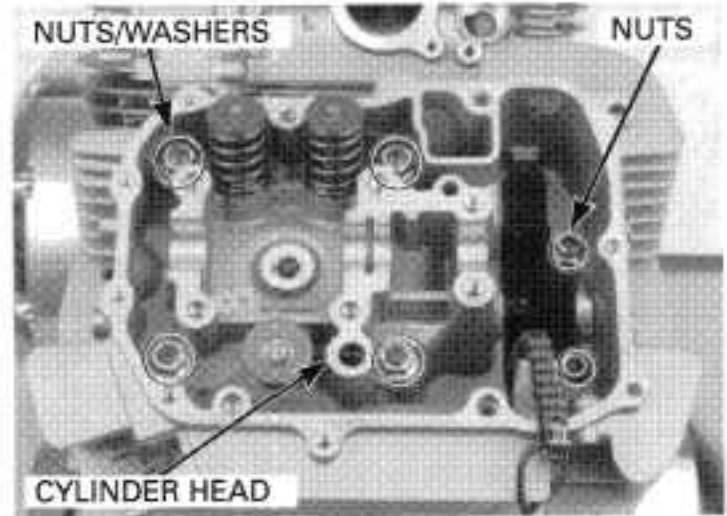

Remove the gasket and dowel pins.

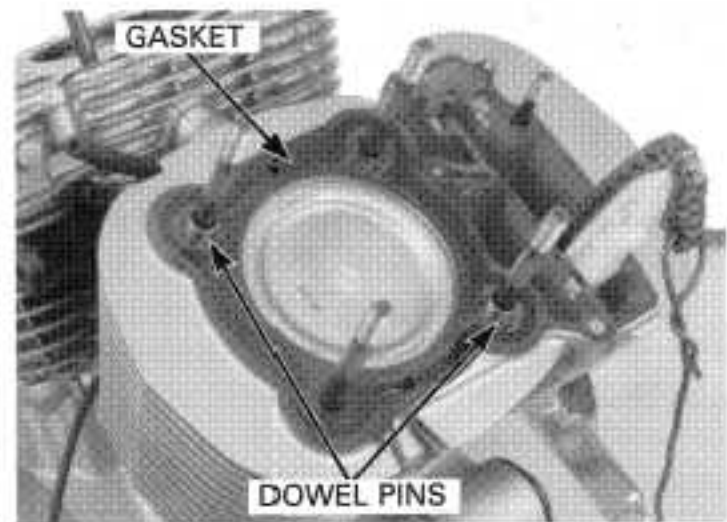

Remove the cam chain guide.

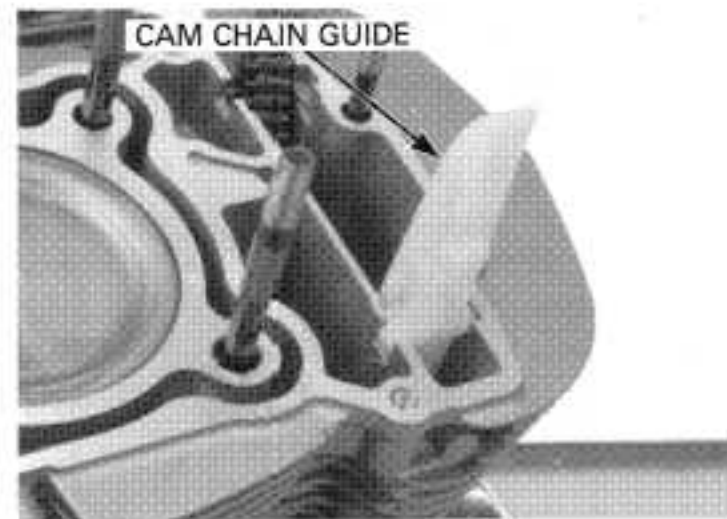

## CYLINDER HEAD DISASSEMBLY

Remove the cylinder head (page 8-9).  
Remove the cam pulse generator (front cylinder head only, page 5-75).

*Compressing the valve springs more than necessary will cause loss of valve spring tension.*

Remove the valve spring cotters using the valve spring compressor.

**TOOL:**  
Valve spring compressor      07757-0010000

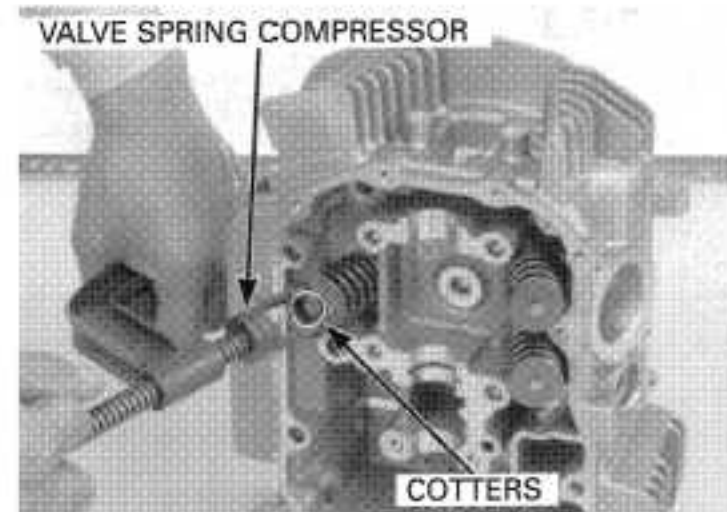



*Mark all parts during disassembly so they can be placed back in their original locations during installation.*

Remove the valve spring compressor, then remove the retainer, spring and valve.

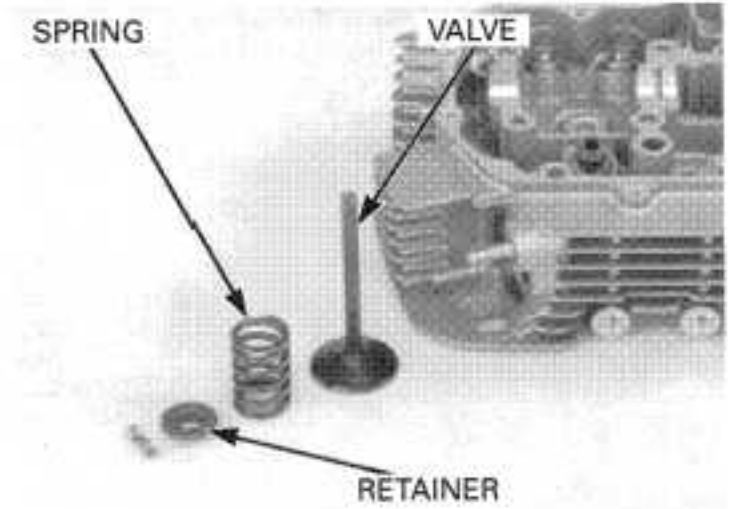

*Do not reuse a removed stem seal.*

Remove the stem seals and spring seats.  
Do not reuse a removed stem seal.

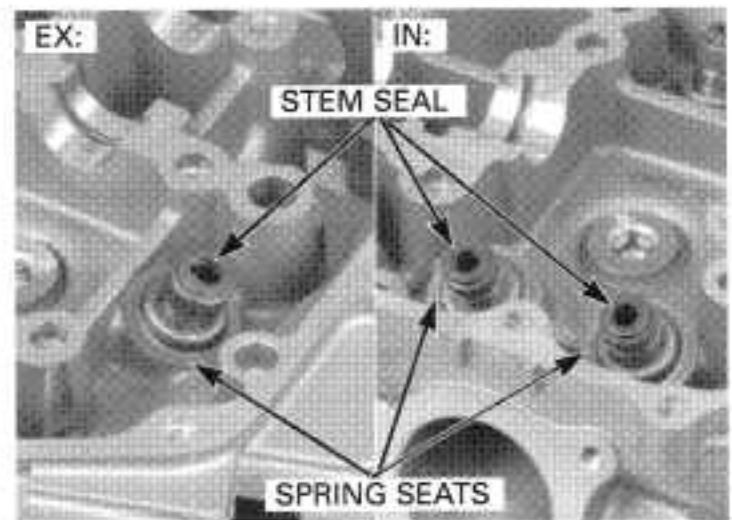

*Gasket material will come off easier if soaked in high flash point cleaning solvent.*

Remove the carbon deposits from the combustion chamber to avoid damaging the gasket and valve seat surfaces and clean the head gasket surfaces

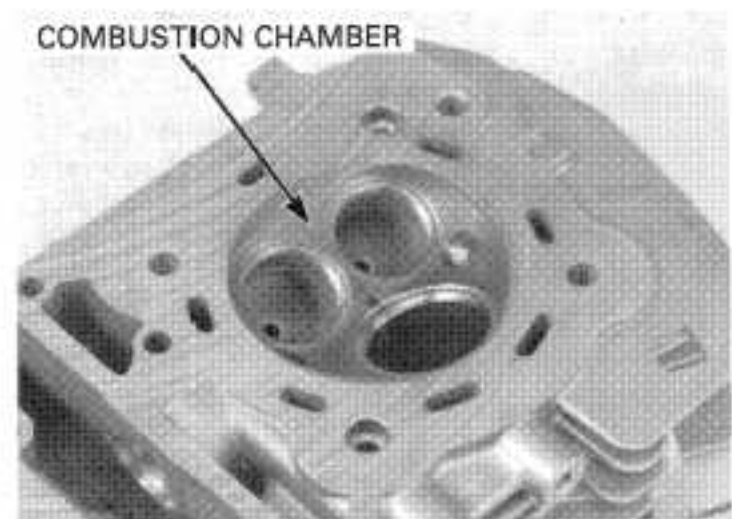

**INSPECTION**

**CYLINDER HEAD**

Check the spark plug holes and valve areas for cracks.

Check the cylinder head for warpage with a straight edge and feeler gauge.

**SERVICE LIMIT: 0.10 mm (0.004 in)**

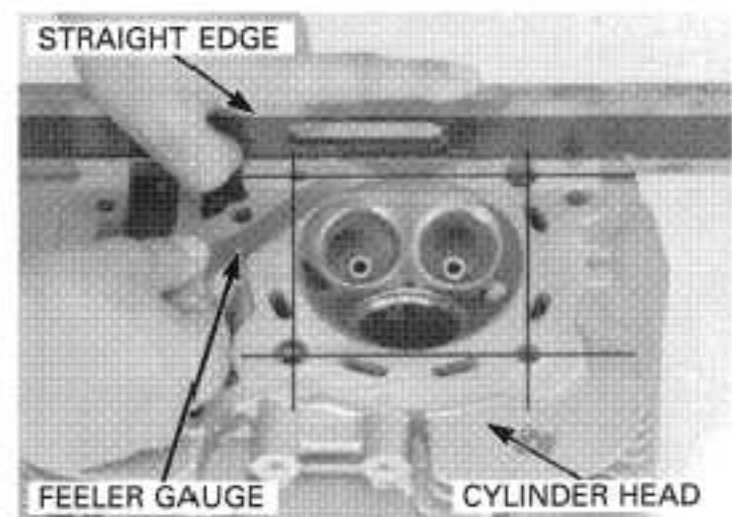



## CYLINDER HEAD/VALVES

### VALVE SPRING

Measure the free length of the valve springs.

**SERVICE LIMITS:** IN: 41.9 mm (1.65 in)  
EX: 42.4 mm (1.67 in)

VALVE SPRING

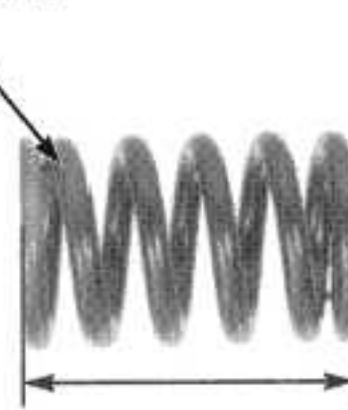

### CAM CHAIN TENSIONER/CAM CHAIN GUIDE

Inspect the cam chain tensioner and guide for excessive wear or damage, replace if necessary.

CAM CHAIN GUIDE

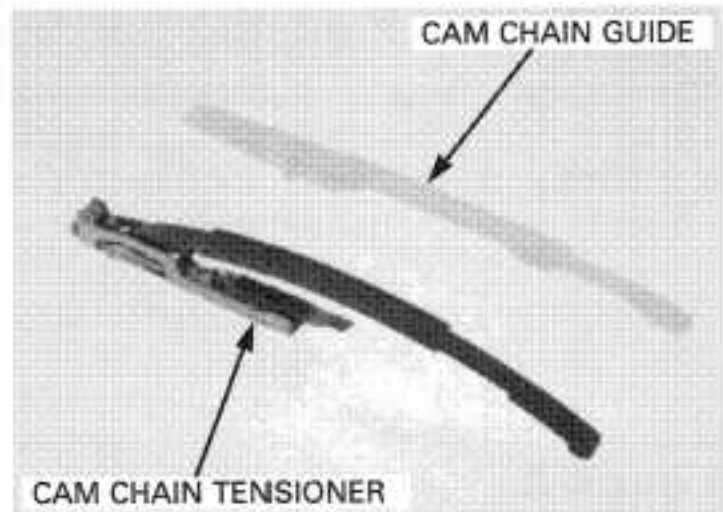

CAM CHAIN TENSIONER

### VALVE/VALVE GUIDE

Inspect each valve for bends, burns, scratches or abnormal wear.

Insert the valves in their original positions in the cylinder head. Check that each valve moves up and down smoothly, without binding.

Measure each valve stem O.D. and record it.

**SERVICE LIMITS:** IN: 6.57 mm (0.259 in)  
EX: 7.94 mm (0.313 in)

VALVE

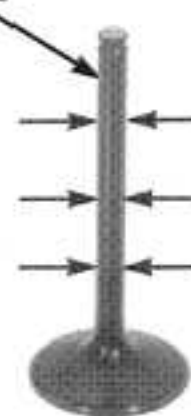

Ream the valve guide to remove any carbon build-up before measuring the guide.

Insert the reamer from the combustion chamber side of the head and rotate the reamer clockwise.

### TOOLS:

IN: Valve guide reamer, 6.6 mm 07984-657010D  
EX: Valve guide reamer, 8 mm 07ZMH-MCHA200

VALVE GUIDE REAMER

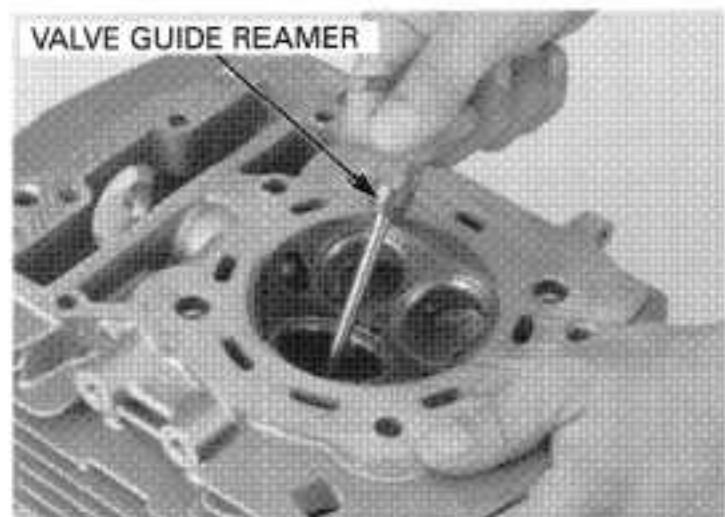

Measure the valve guide I.D. and record it.

**SERVICE LIMITS: IN: 6.635 mm (0.2612 in)**  
**EX: 8.055 mm (0.3171 in)**

Subtract each valve stem O.D. from the corresponding guide I.D. to obtain the stem-to-guide clearance.

**SERVICE LIMITS: IN: 0.08 mm (0.003 in)**  
**EX: 0.12 mm (0.005 in)**

If the stem-to-guide clearance exceeds the service limit, determine if a new guide with standard dimensions would bring the clearance within tolerance. If so, replace any guides as necessary and ream to fit. If the stem-to-guide clearance exceeds the service limit with a new guide, also replace the valve.

Inspect and reface the valve seats whenever the valve guides are replaced (see below).



## VALVE GUIDE REPLACEMENT

Chill the valve guides in a freezer for approximately 1 hour.

*Wear insulated gloves to avoid burns when handling the heated cylinder head.*

Heat the cylinder head to 130 °C – 140 °C (275 °F – 290 °F) with a hot plate or oven. Do not heat the cylinder head beyond 150 °C (300 °F). Use temperature indicator sticks, available from welding supply stores, to be sure the cylinder head is heated to the proper temperature.

### NOTICE

*Using a torch to heat the cylinder head may cause warpage.*

Support the cylinder head and drive out the old guides from the combustion chamber side of the cylinder head.

### TOOLS:

**IN: Valve guide driver, 6.6 mm      07942-6570100**  
**EX: Valve guide driver, 8 mm      07ZMD-MCHA100**

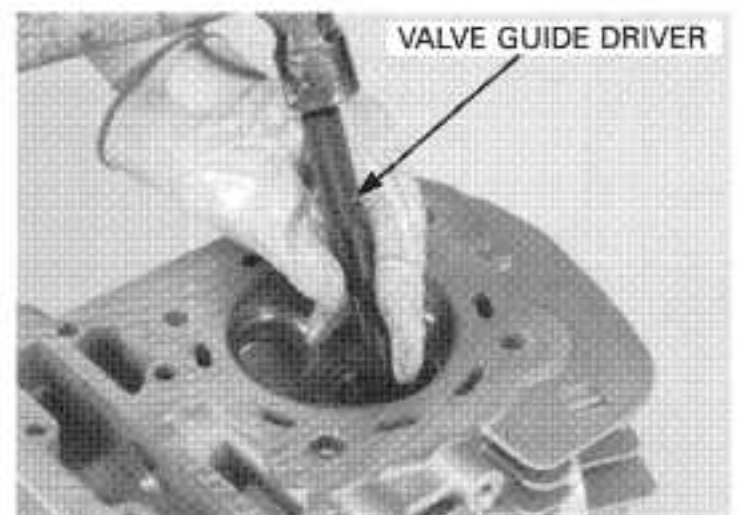

## CYLINDER HEAD/VALVES

Drive the new guides in from the camshaft side of the cylinder head while the cylinder head is still heated.

### TOOLS:

IN: Valve guide driver, 6.6 mm 07942-6570100  
EX: Valve guide driver, 8 mm 07ZMD-MCHA100

### VALVE GUIDE PROJECTION ABOVE CYLINDER HEAD:

IN: 16.4 – 16.6 mm (0.646 – 0.654 in)  
EX: 17.7 – 17.9 mm (0.697 – 0.705 in)

Let the cylinder head cool to room temperature, then ream the new valve guides.

### TOOLS:

IN: Valve guide reamer, 6.6 mm 07984-657010D  
EX: Valve guide reamer, 8 mm 07ZMH-MCHA200

- When reaming, do not tilt the reamer or the valve will be slanted after installation. A slanted valve will result in oil leaking past the stem seal. This will cause improper valve seat contact resulting in a valve seat that cannot be refaced.
- Insert the reamer from the combustion chamber side of the head and always rotate the reamer clockwise.

Clean the cylinder head thoroughly to remove any metal particles after reaming and then reface the valve seat.

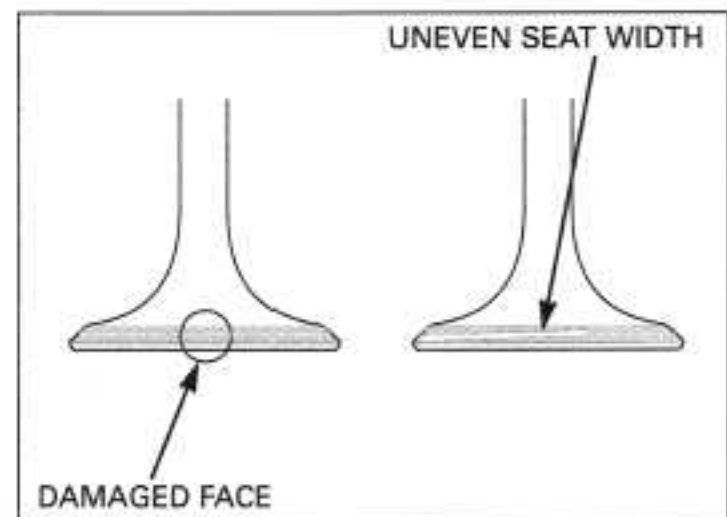
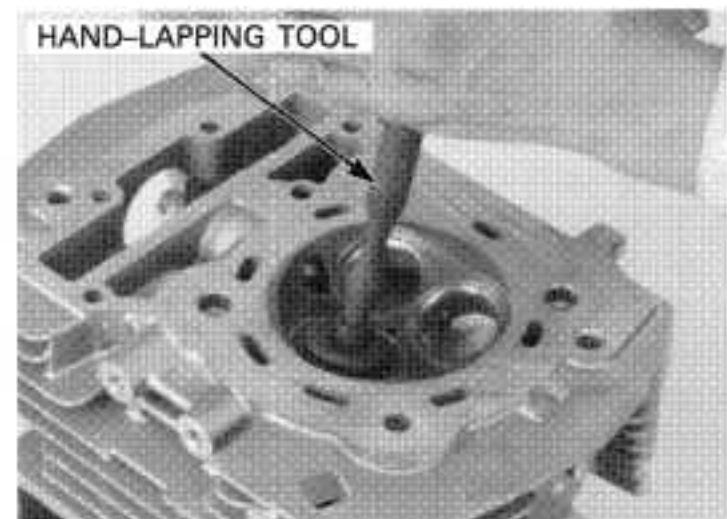
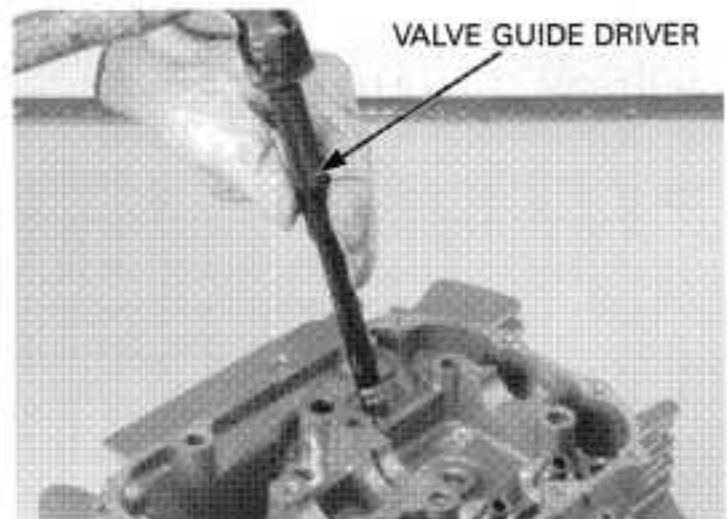

## VALVE SEAT INSPECTION/REFACING

### INSPECTION

Clean all intake and exhaust valves thoroughly to remove the carbon deposits.

Apply a light coat of Prussian Blue to each valve face. Tap the valve against the valve seat several times using a hand-lapping tool, without rotating the valve, to make a clear pattern.

Remove the valve and inspect the valve seat face (see following page).

The valve cannot be ground. If the valve face is burned or badly worn or if it contacts the seat unevenly, replace the valve.

Inspect the valve seat face for:

- Damaged face:
  - Replace the valve and reface the valve seat.
- Uneven seat width:
  - Bent or collapsed valve stem;
  - Replace the valve and reface the valve seat.

- Contact area (too low or too high area)  
— Reface the valve seat.

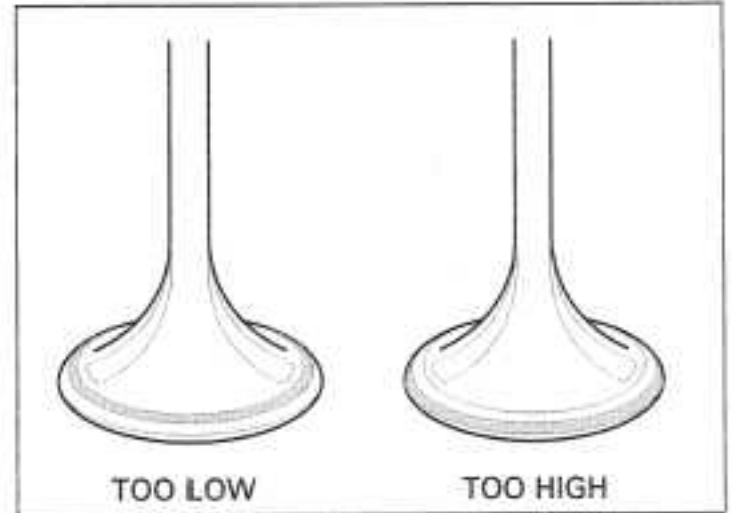

Inspect the width of the valve seat.  
The valve seat contact should be within the specified width and even all around the circumference.

**STANDARD:** IN: 1.10 – 1.30 mm (0.043 – 0.051 in)  
EX: 1.40 – 1.60 mm (0.055 – 0.063 in)  
**SERVICE LIMIT:** IN: 1.70 mm (0.669 in)  
EX: 2.00 mm (0.079 in)

If the valve seat width is not within specification, reface the valve seat.

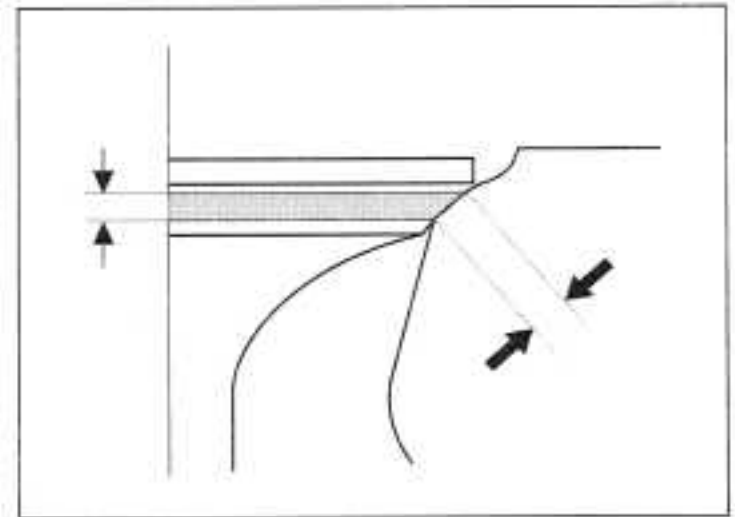

### VALVE SEAT REFACING

- Follow the refacer manufacturer's operating instructions.
- Be careful not to grind the seat more than necessary.

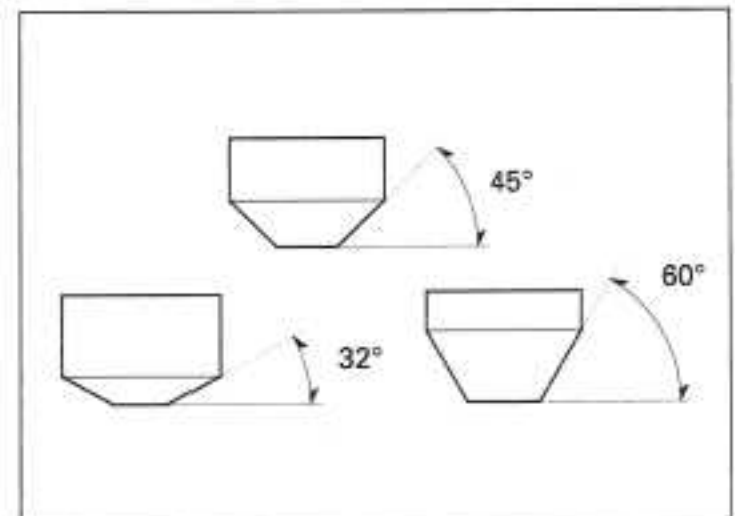

If the contact area is too high on the valve, the seat must be lowered using a 32° flat cutter.

If the contact area is too low on the valve, the seat must be raised using a 60° inner cutter. Refinish the seat to specification, using a 45° finish cutter.

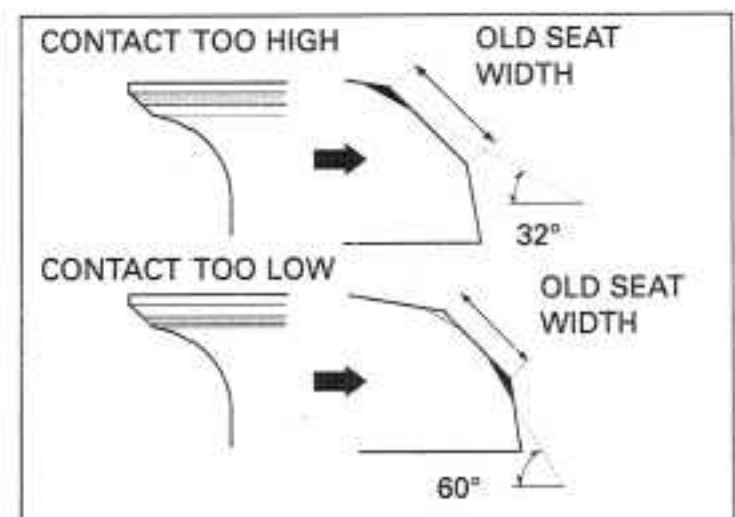

## CYLINDER HEAD/VALVES

Using a 45° cutter, remove any roughness or irregularities from the seat.

**TOOLS:**

Seat cutter, 40 mm (45° IN)	07780-0010500
Seat cutter, 46 mm (45° EX)	07780-0011200
Cutter holder, 6.6 mm	07781-0010202 or 07942-ZE2000D (U.S.A. only)
Cutter holder, 8 mm	07ZMH-MCH0100

or equivalent commercially available in U.S.A.

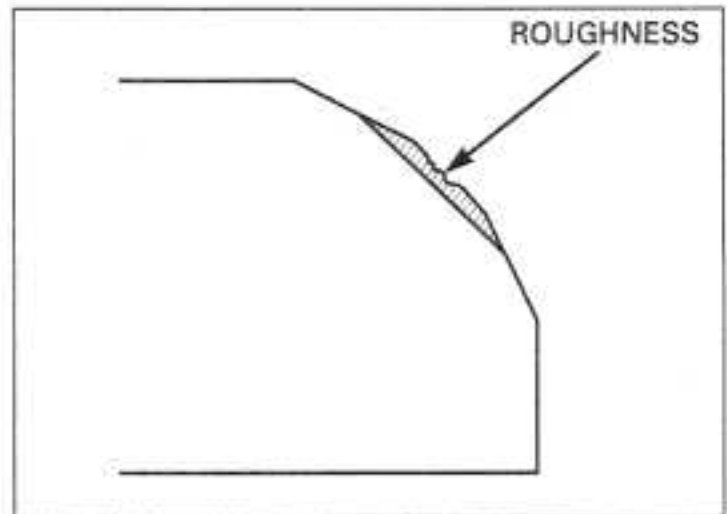

Using a 32° cutter, remove 1/4 of the existing valve seat material.

**TOOLS:**

Flat cutter, 38.5 mm (32° IN)	07780-0012400
Flat cutter, 50mm (32° EX)	07780-0013600
Cutter holder, 6.6 mm	07781-0010202 or 07942-ZE2000D (U.S.A. only)
Cutter holder, 8 mm	07ZMH-MCH0100

or equivalent commercially available in U.S.A.

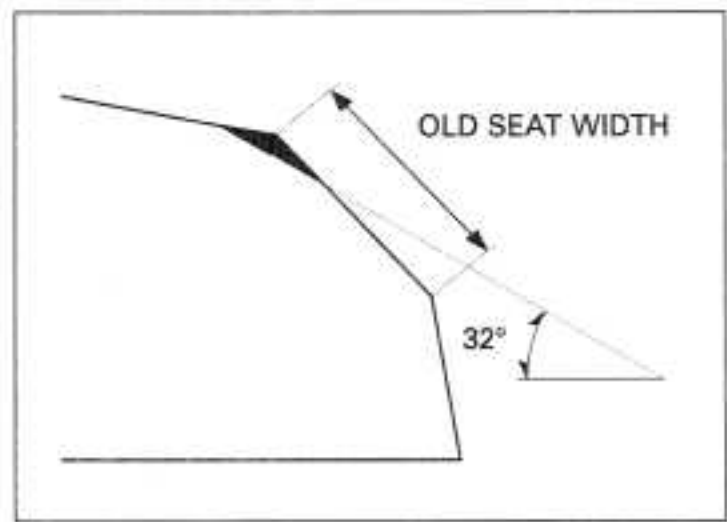

Using a 60° cutter, remove the bottom 1/4 of the old seat.

**TOOLS:**

Interior cutter, 34 mm (60° IN)	07780-0014700
Interior cutter, 45mm (60° EX)	07780-0014800
Cutter holder, 6.6 mm	07781-0010202 or 07942-ZE2000D (U.S.A. only)
Cutter holder, 8 mm	07ZMH-MCH0100

or equivalent commercially available in U.S.A.

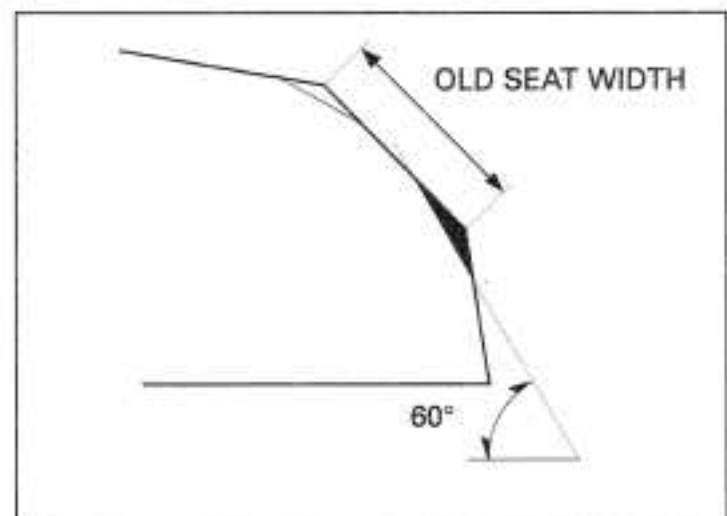

Using a 45° cutter, cut the seat to the proper width.

Make sure all pitting and irregularities are removed.

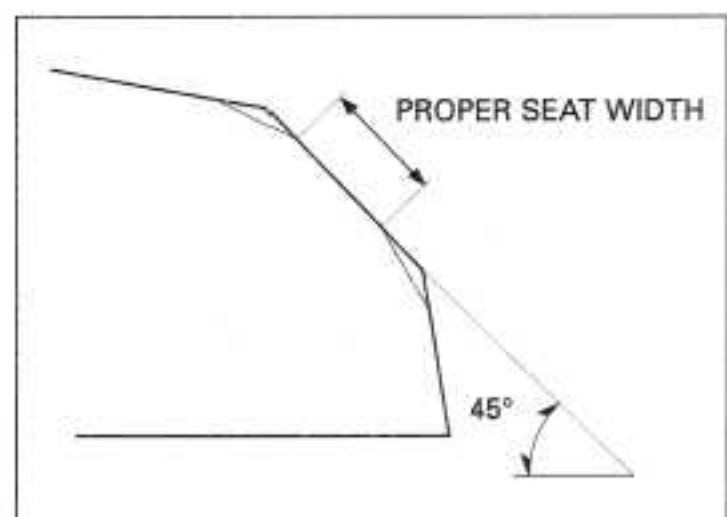



Change the angle of the lapping tool frequently to prevent uneven seat wear.

*Lapping compound can cause damage if it enters between the valve stem and guide.*

After cutting the seat, apply lapping compound to the valve face, and lap the valve using light pressure.

After lapping, wash any residual compound off the cylinder head and valve.

Recheck the seat contact after lapping.

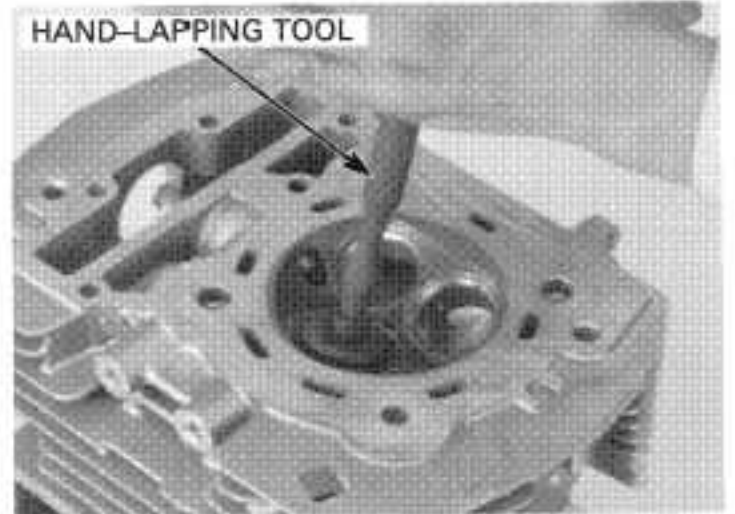

## CYLINDER HEAD ASSEMBLY

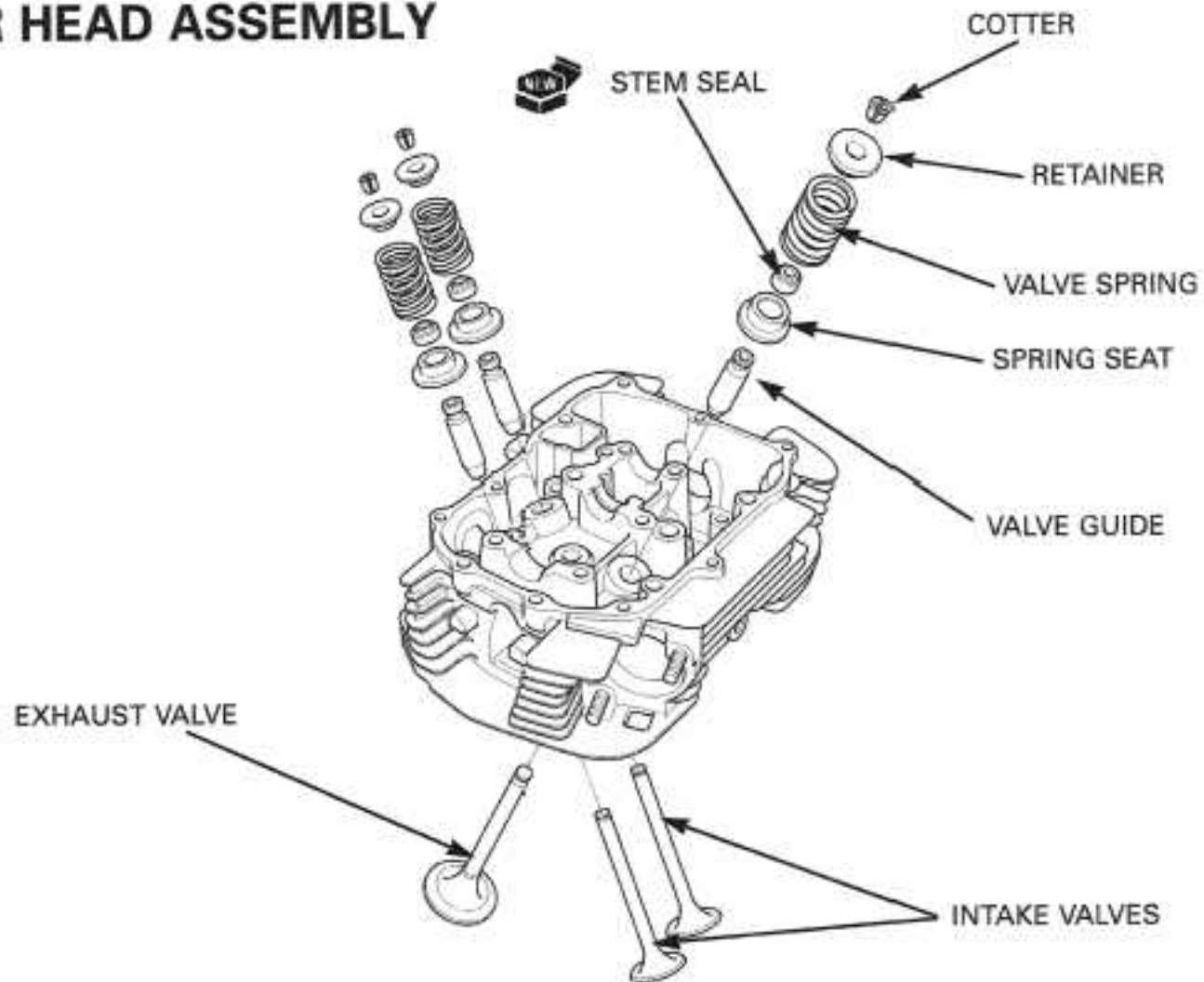

Blow out all oil passages in the cylinder head with compressed air.

Lubricate each valve stem with molybdenum oil solution.

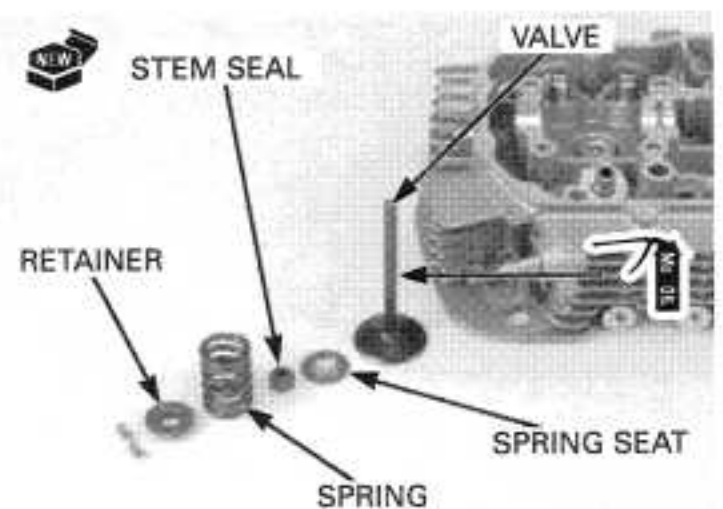

## CYLINDER HEAD/VALVES

Install the spring seats and new stem seals.

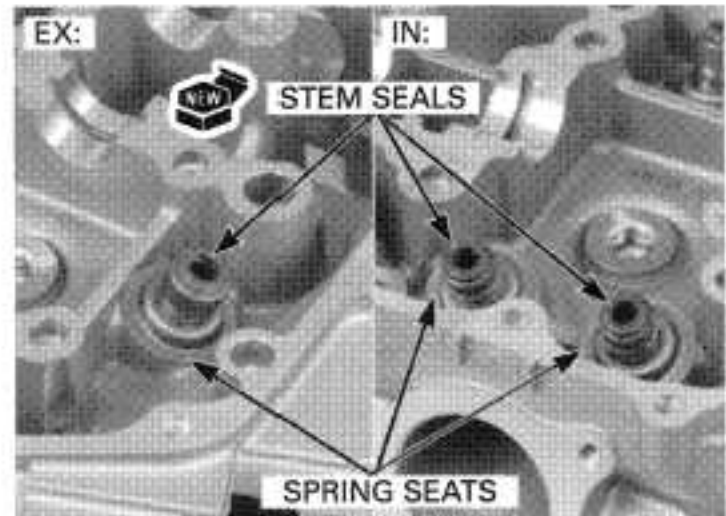

Insert the valves into the valve guides.  
To avoid damaging the stem seal, turn the valve slowly when inserting.  
Install the valve springs.  
Install the spring retainers.

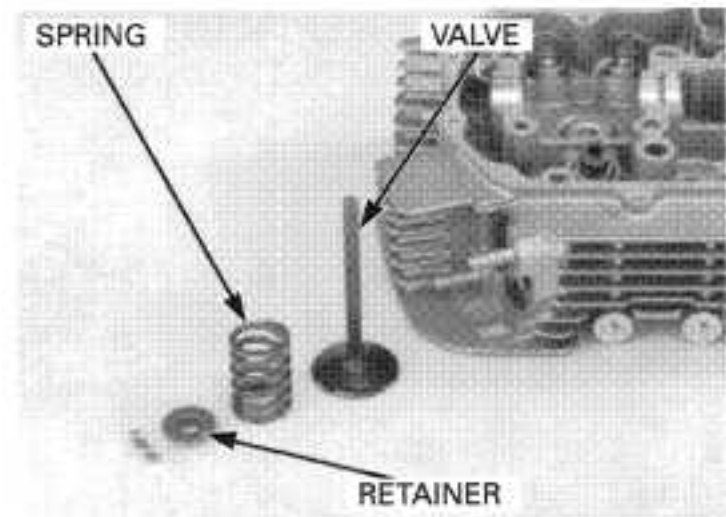

*Grease the cotter to ease installation.  
Compressing the valve springs more than necessary when installing the valve cotter may cause loss of valve spring tension.*

Compress the valve springs with the valve spring compressor and install the valve cotters.

**TOOL:**  
**Valve spring compressor 07757-0010000**

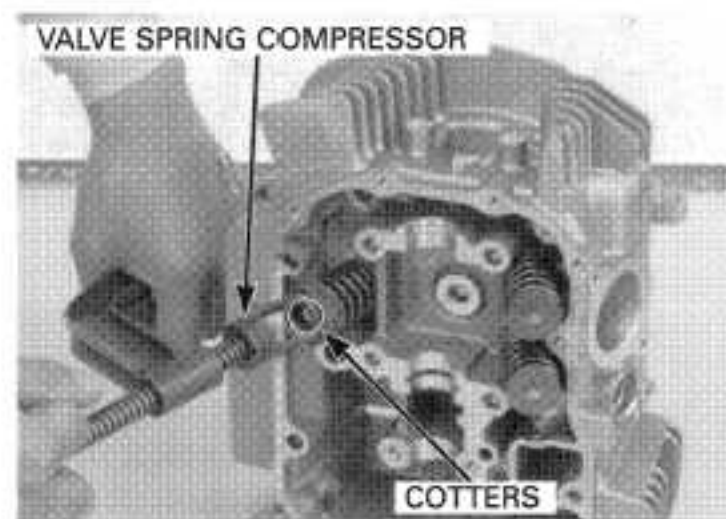

*Support the cylinder head above the work bench surface to prevent possible valve damage.*

Tap the valve stems gently with a soft hammer to firmly seat the cotters.

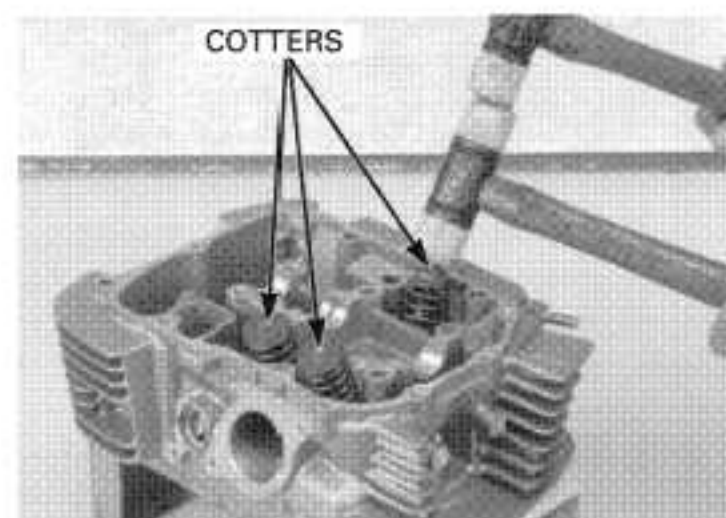

## CYLINDER HEAD INSTALLATION

Clean any gasket material from the cylinder mating surfaces.

Make sure the cam chain guide bosses are in the grooves of the cylinder.

Install the dowel pins and new gasket.

The cylinder head has the following identification mark:

"F": Front cylinder

"R": Rear cylinder

Install the cylinder head onto the cylinder.

Apply engine oil to the threads and seating surfaces of the cylinder head mounting nuts.

Install the washer and cylinder head mounting nuts. Tighten the cylinder head mounting nuts to the specified torque.

**TORQUE:** 10 mm: 49 N·m (5.0 kgf·m, 39 lbf·ft)  
8 mm: 26 N·m (2.7 kgf·m, 20 lbf·ft)

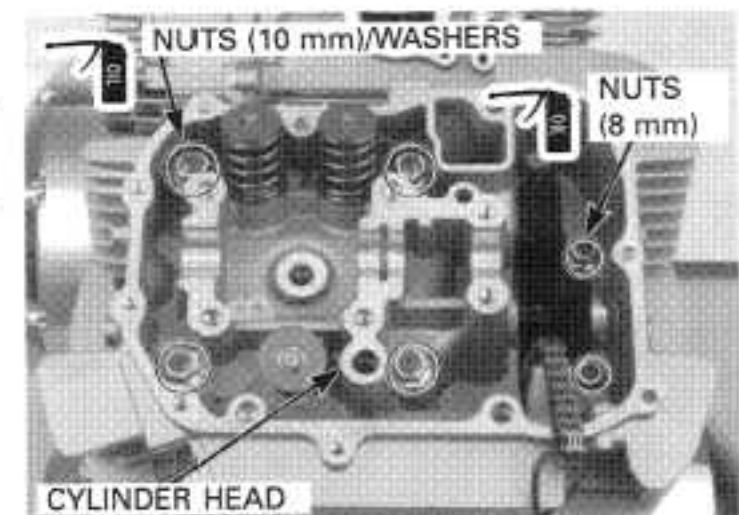
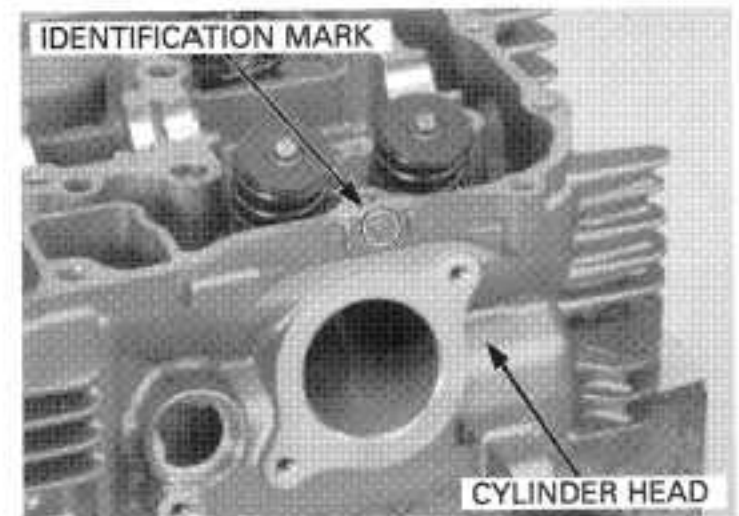
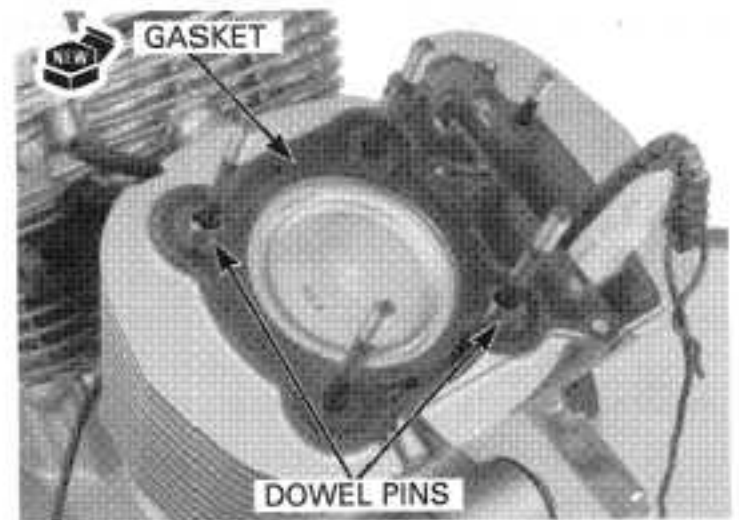
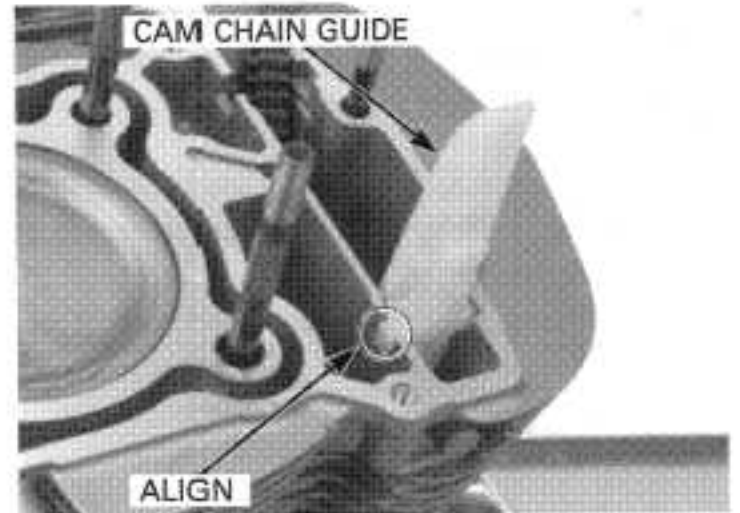

## CYLINDER HEAD/VALVES

Install the cam chain tensioner into the cylinder head.

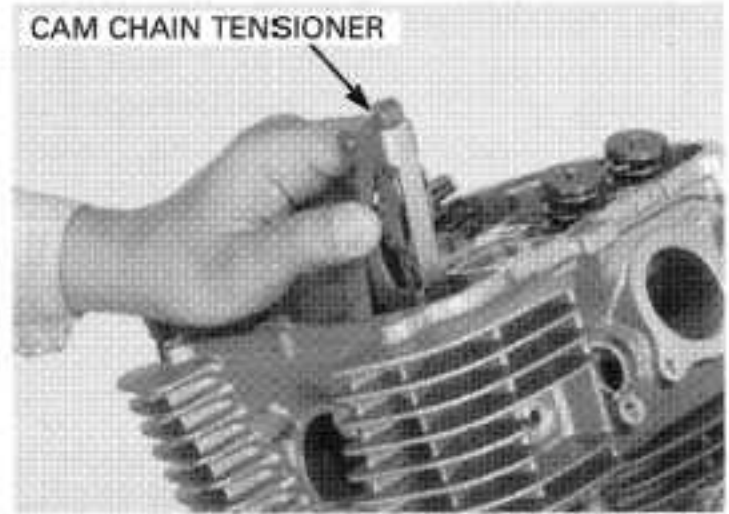

Install the cam chain tensioner bolts with new washers. Tighten the bolts to the specified torque.

**TORQUE: 12 N·m (1.2 kgf·m, 9 lbf·ft)**

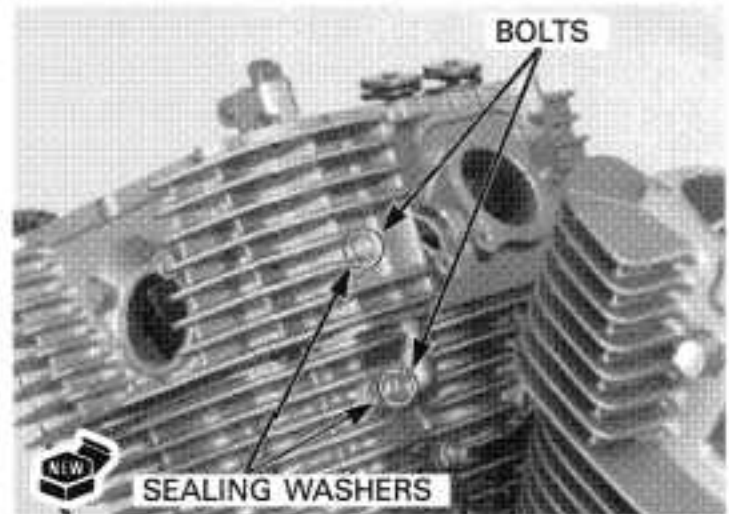

## CAMSHAFT INSTALLATION

### CAMSHAFT HOLDER ASSEMBLY

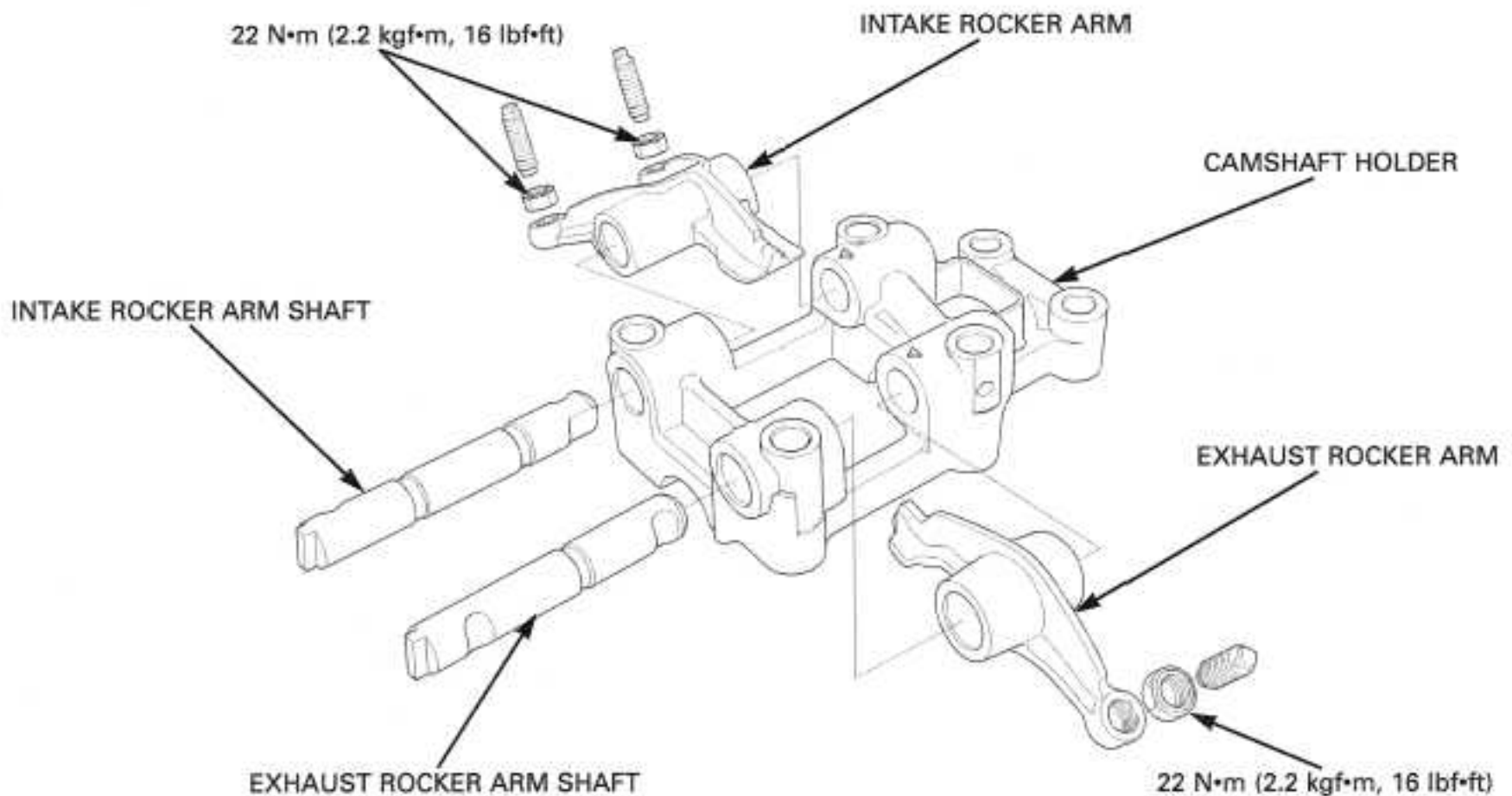



Clean the oil passages before assembling the cylinder head and camshaft holder.

Lubricate each rocker arm shaft outer sliding surface with molybdenum oil solution.

The intake rocker arm shaft is longer than the exhaust rocker arm shaft.

Install the intake rocker arm and rocker arm shaft to the camshaft holder.

Install the exhaust rocker arm and rocker arm shaft to the camshaft holder.

Align the grooves in the rocker arms with the bolt holes on the camshaft holder by turning the rocker arm shafts.

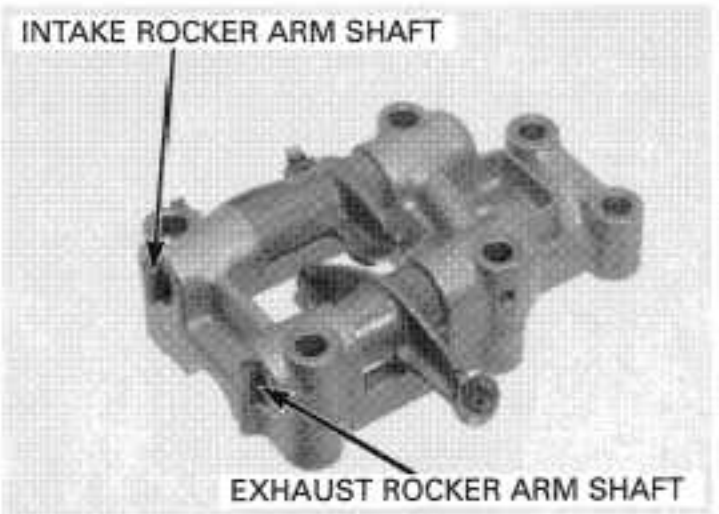
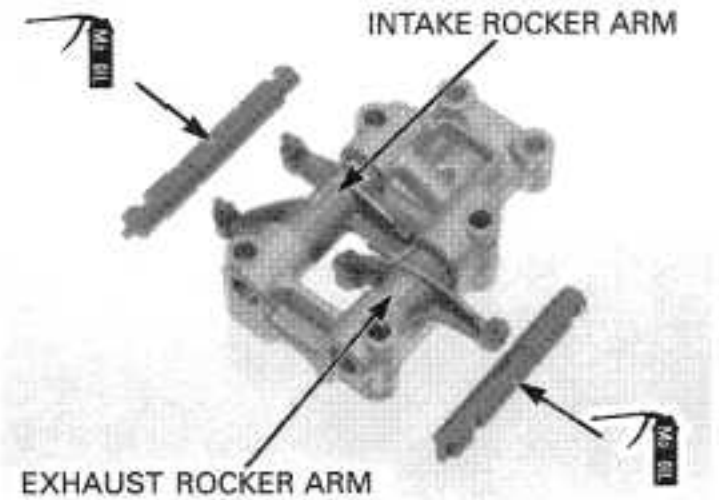

**CAMSHAFT INSTALLATION**

- If both front and rear camshafts were removed, start camshaft installation with the front cylinder as described below.
- Even if you are servicing either the front or rear cylinder head, the other cylinder head cover must be removed and the other camshaft position must be checked.

Lubricate the camshaft journal surfaces of the cylinder head with molybdenum oil solution.

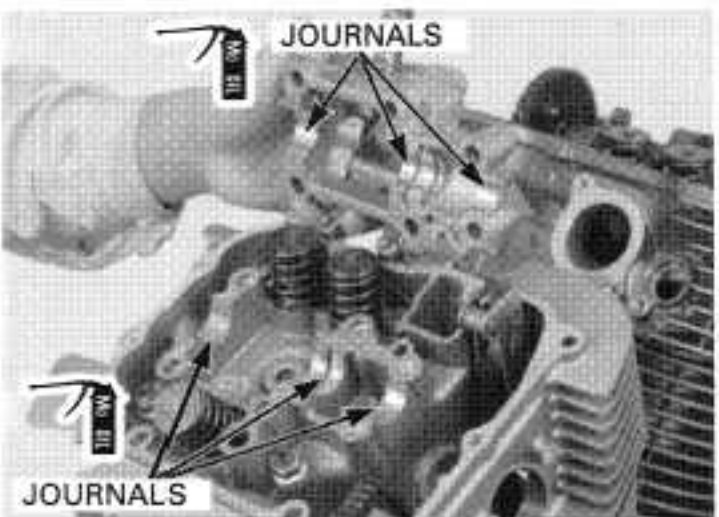

If the cam sprockets are removed, install them onto the camshaft.

Install the cam sprocket bolts.

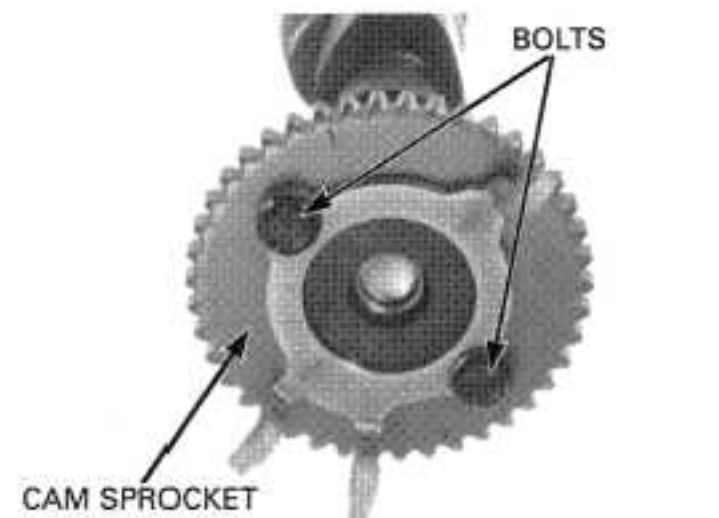



## CYLINDER HEAD/VALVES

The camshafts have the following identification marks:

"F": Front cylinder camshaft

"R": Rear cylinder camshaft

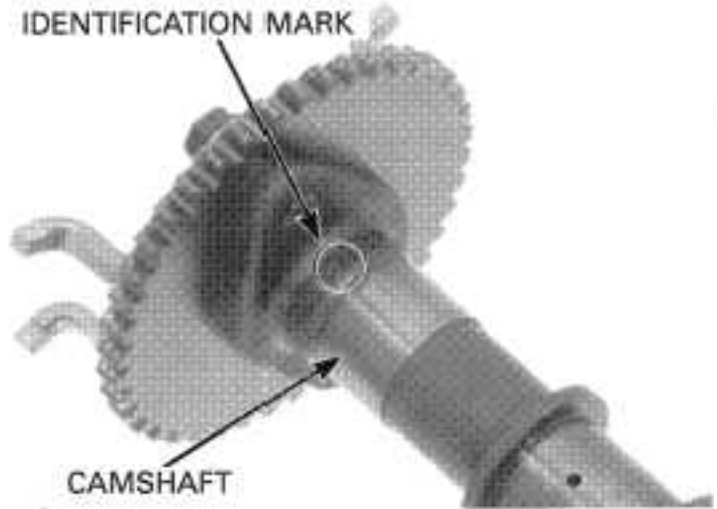

### FRONT CYLINDER

*If the rear cylinder camshaft has not been serviced, begin here.*

If the rear cylinder camshaft has not been serviced, remove the rear cylinder head cover and check the rear cylinder camshaft position as follows:

Turn the crankshaft clockwise and align the "RT" mark on the primary drive gear with the index mark on the right crankcase cover.

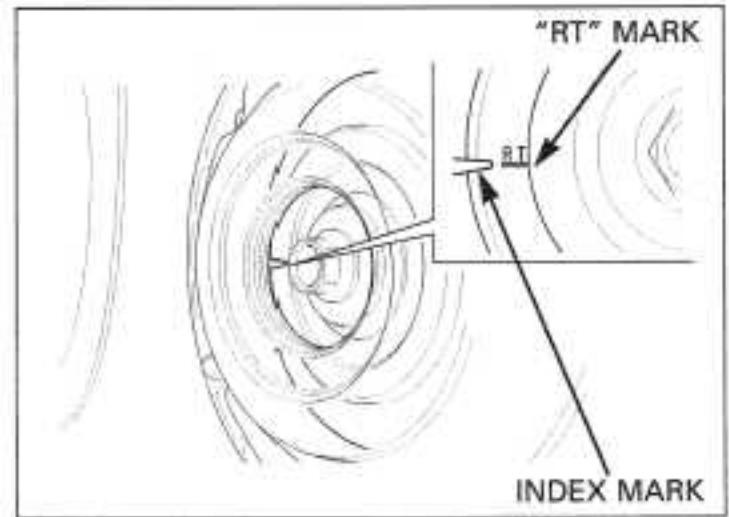

Check the index lines on the rear cylinder camshaft as shown.

If the index lines on the rear cylinder camshaft do not align with the rear cylinder mating surface, turn the crankshaft clockwise 1 turn (360°) and align the "RT" mark with the index mark.

Check the index lines on the rear cylinder camshaft as shown.

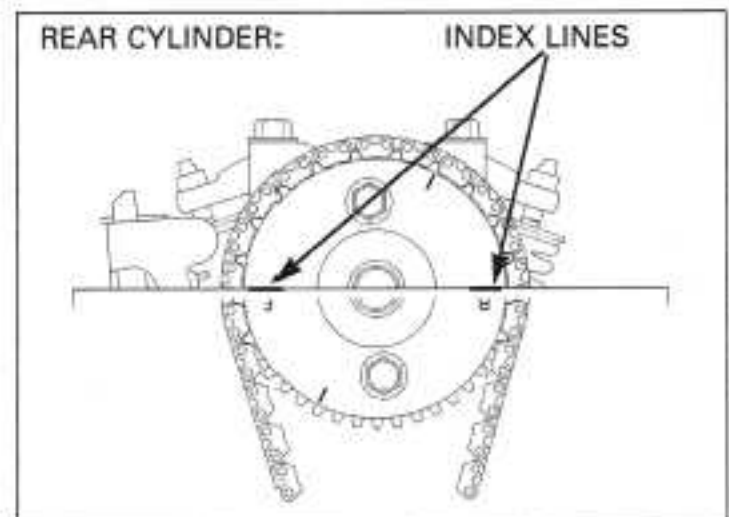

*If the rear cylinder camshaft has been serviced, begin installation of the front cylinder camshaft here.*

Turn the crankshaft clockwise 16/45 of a turn (128°) and align the "FT" mark with the index mark.

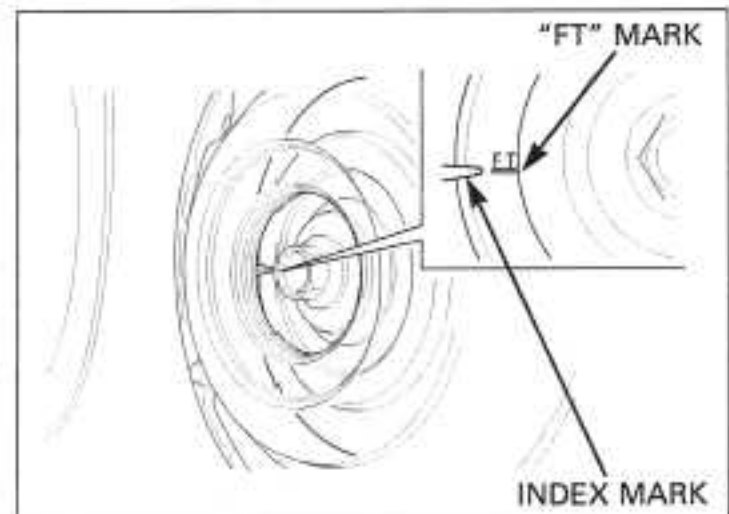

Apply molybdenum oil solution to the camshaft journals and cam lobes.

Install the cam sprocket onto the cam chain with the index mark facing upright and align the index lines with the upper surface of the cylinder head.

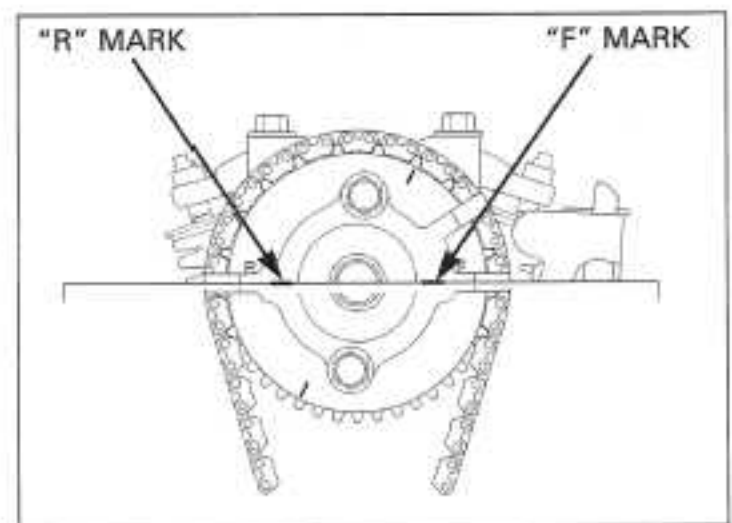
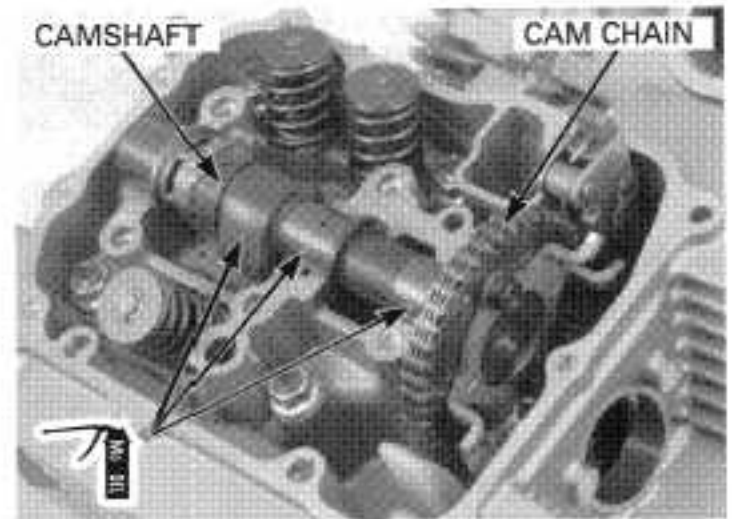

Install the dowel pins.

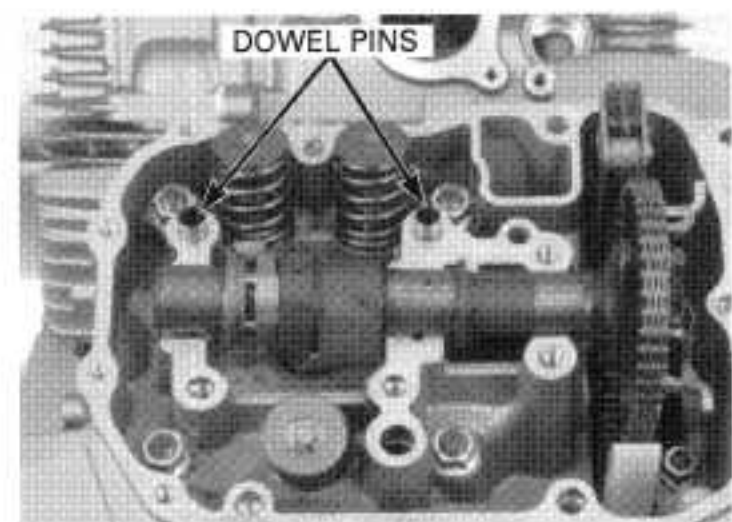

Install the camshaft holder assembly.  
Apply oil to the camshaft holder bolt threads and flange surface.  
Install and tighten the camshaft holder bolts to the specified torque.

**TORQUE: 26 N·m (2.7 kgf·m, 20 lbf·ft)**

If the cam sprockets are removed, tighten the cam sprocket bolt to the specified torque.

**TORQUE: 23 N·m (2.3 kgf·m, 17 lbf·ft)**

Turn the crankshaft one revolution and tighten the other side cam sprocket bolt to the specified torque.

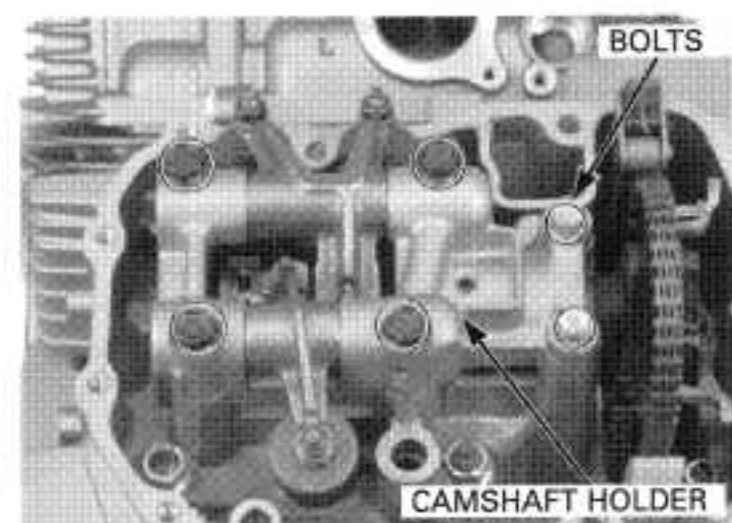

## CYLINDER HEAD/VALVES

Apply engine oil to the spark plug sleeve threads and O-ring grooves.  
Install the new O-rings into the spark plug sleeve grooves.

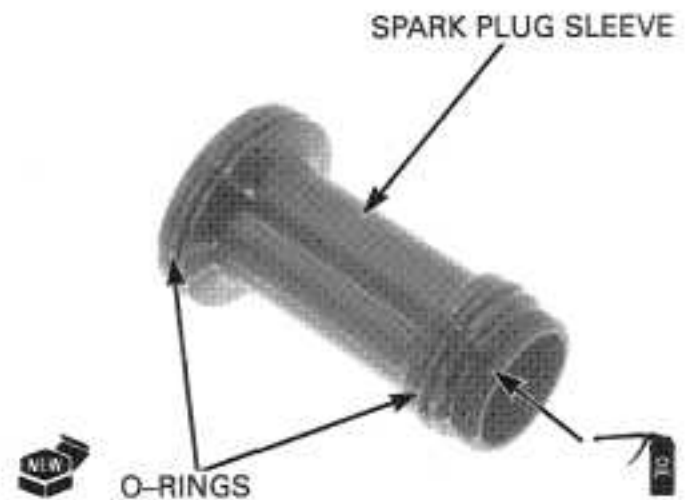

Install and tighten the spark plug sleeve to the specified torque.

**TOOL:**  
Holder attachment                      07930-KA50100

**TORQUE:** 18 N·m (1.8 kgf·m, 13 lbf·ft)

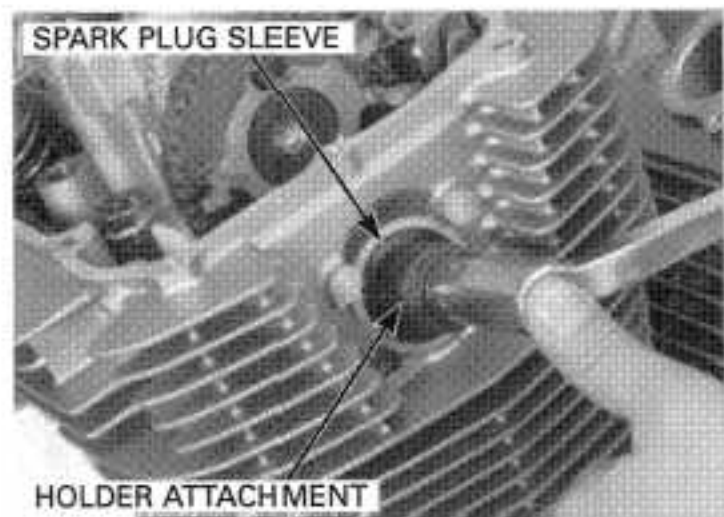

## REAR CYLINDER

Turn the crankshaft clockwise and align the "FT" mark on the primary drive gear with the index mark on the right crankcase cover.

- If the "F" mark on the front camshaft flange faces up, turn the crankshaft clockwise  $29/45$  of a turn ( $232^\circ$ ) and align the "RT" mark with the index mark.
- If the "F" mark on the front camshaft flange faces down (cannot be seen), turn the crankshaft clockwise  $1-29/45$  turns ( $592^\circ$ ) and align the "RT" mark with the index mark.

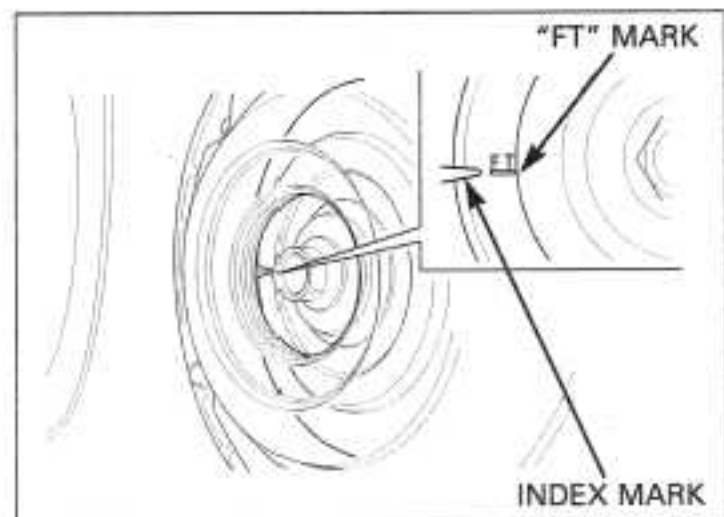

The remainder of the rear cylinder camshaft installation is the same as the procedures described on page 8-22 except the mark on the camshaft flange that should face up should be an "R".

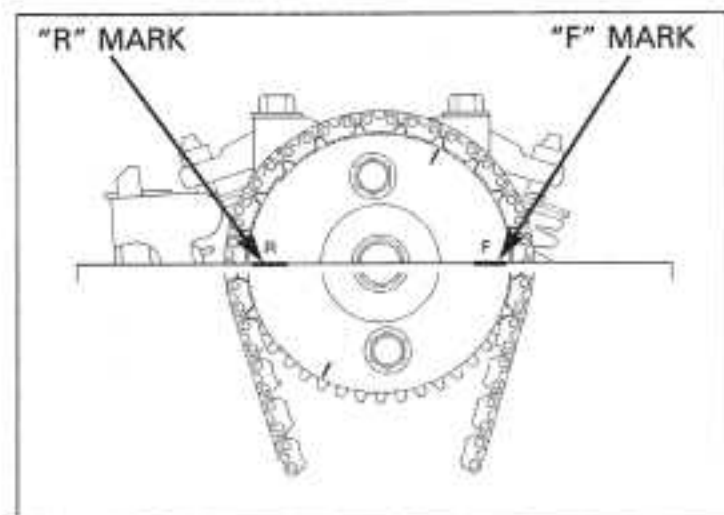

Remove the 2 mm pin that holds cam chain tensioner wedge A (remove the pin on both tensioners).

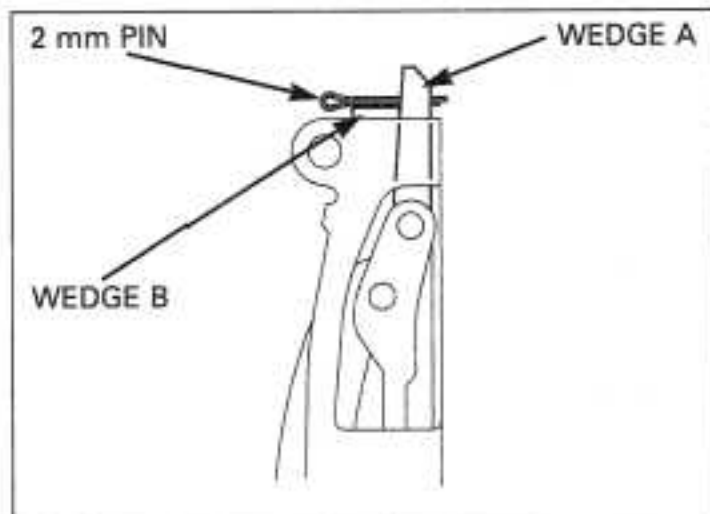

## CYLINDER HEAD COVER INSTALLATION

Clean any sealant material from the cylinder head cover mating surfaces.

Apply liquid sealant to the mating surfaces of the cylinder head cover.

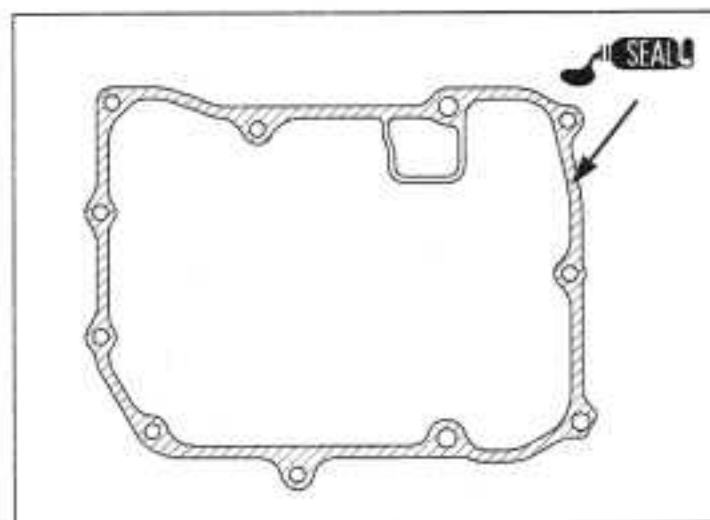

Install the new O-ring.  
Install the dowel pins to the cylinder head.

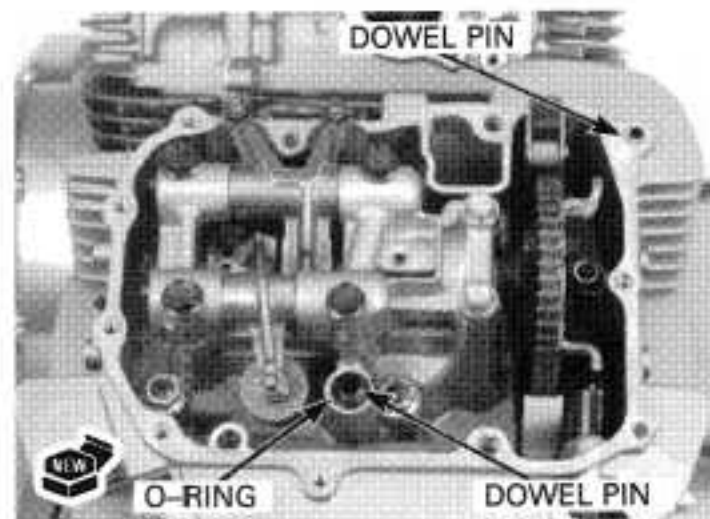

Install the cylinder head cover.

Install and tighten the cylinder head cover 8 mm bolts and 6 mm bolts to the specified torque.

**TORQUE: 8 mm bolts: 26 N·m (2.7 kgf·m, 20 lbf·ft)**  
**6 mm bolts: 12 N·m (1.2 kgf·m, 9 lbf·ft)**

Install the valve adjusting cover (page 3-11).  
Install the PAIR check valve (page 5-82).  
Install the engine from the frame (section 7).

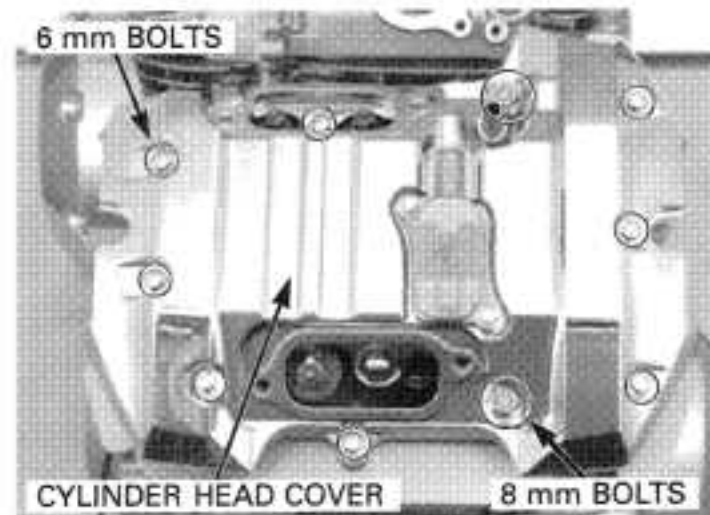

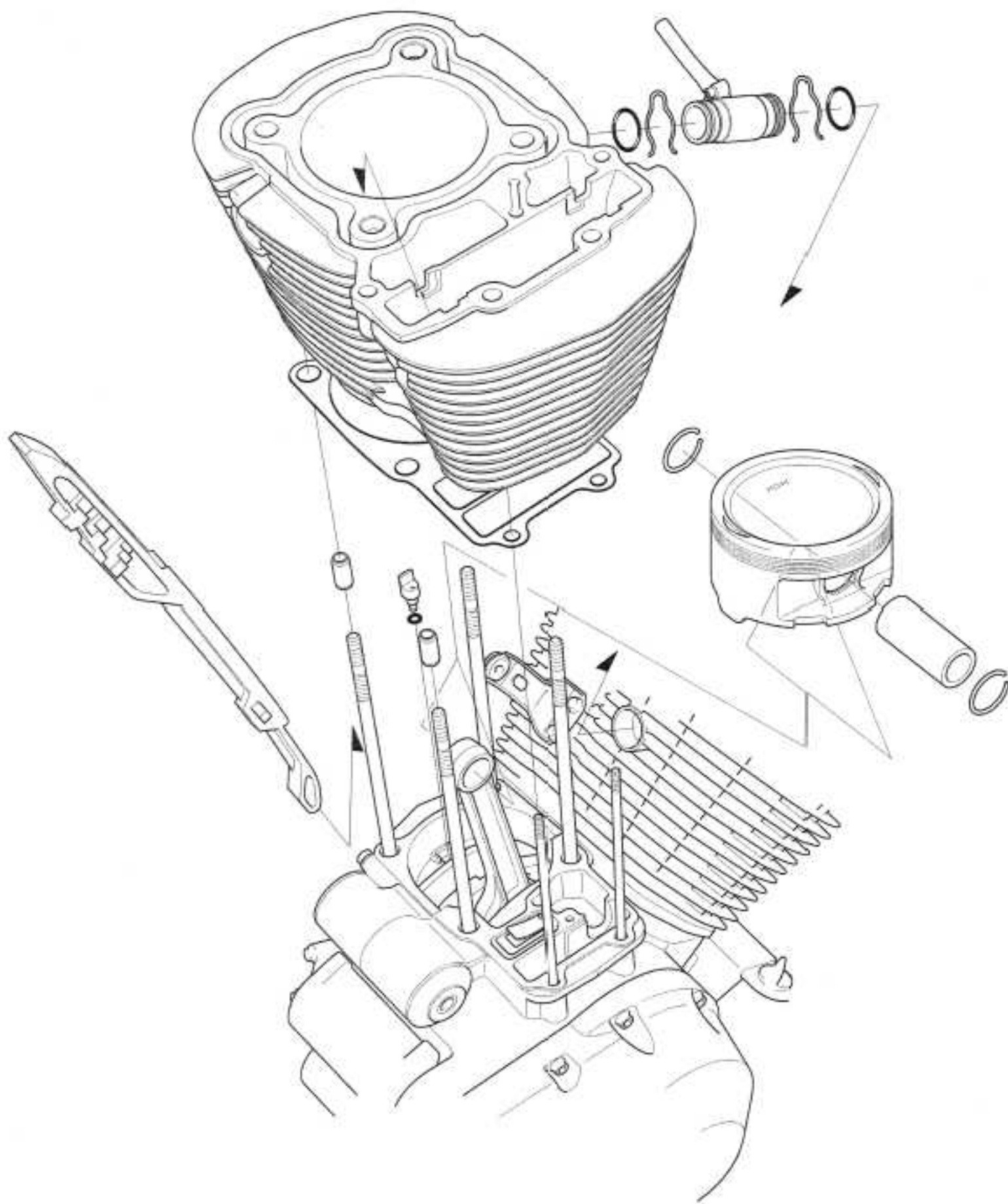



# 9. CYLINDER/PISTON

<b>SERVICE INFORMATION</b>	<b>9-1</b>	<b>PISTON RING INSTALLATION</b>	<b>9-8</b>
<b>TROUBLESHOOTING</b>	<b>9-2</b>	<b>PISTON INSTALLATION</b>	<b>9-9</b>
<b>CYLINDER REMOVAL</b>	<b>9-3</b>	<b>CYLINDER INSTALLATION</b>	<b>9-10</b>
<b>PISTON REMOVAL</b>	<b>9-5</b>		

## SERVICE INFORMATION

### GENERAL

- This section covers service of the cylinder and piston. To service these parts, the engine must be removed from the frame.
- Take care not to damage the cylinder wall and piston.
- Be careful not to damage the mating surfaces when removing the cylinder.
- When removing the piston, clean carbon and sludge from the top of the cylinder.
- When disassembling, mark and store the disassembled parts to ensure that they are reinstalled in their original location.

### SPECIFICATION

Unit: mm (in)

ITEM		STANDARD	SERVICE LIMIT	
Piston, piston rings	Piston O.D. at 18mm (0.7in) from bottom	100.97 – 100.99 (3.9752 – 3.9760)	100.91 (3.973)	
	Piston pin bore I.D.	24.002 – 24.008 (0.9450 – 0.9452)	24.018 (0.9456)	
	Piston pin O.D.	23.994 – 24.000 (0.9446 – 0.9449)	23.984 (0.9443)	
	Piston-to-piston pin clearance	0.002 – 0.014 (0.0001 – 0.0006)	0.034 (0.0013)	
	Piston ring end gap	Top	0.25 – 0.40 (0.010 – 0.016)	0.55 (0.022)
		Second	0.40 – 0.55 (0.016 – 0.022)	0.70 (0.028)
		Oil (side rail)	0.20 – 0.70 (0.008 – 0.028)	0.90 (0.035)
	Piston ring-to-ring groove clearance	Top	0.015 – 0.050 (0.0006 – 0.0020)	0.07 (0.003)
Second		0.015 – 0.050 (0.0006 – 0.0020)	0.07 (0.003)	
Cylinder	I.D.	101.000 – 101.015 (3.9763 – 3.9770)	101.5 (3.978)	
	Out-of-round	—	0.10 (0.004)	
	Taper	—	0.10 (0.004)	
	Warpage	—	0.10 (0.004)	
Cylinder-to-piston clearance		0.01 – 0.045 (0.0004 – 0.0018)	0.32 (0.126)	
Connecting rod small end I.D.		24.020 – 24.041 (0.9457 – 0.9465)	24.051 (0.9469)	
Connecting rod-to-piston pin clearance		0.020 – 0.047 (0.0008 – 0.0019)	0.07 (0.003)	

### TROUBLESHOOTING

#### **Compression too low, hard starting or poor performance at low speed**

- Leaking cylinder head gasket
- Worn, stuck or broken piston ring
- Worn or damaged cylinder and piston

#### **Compression too high, overheating or knocking**

- Excessive carbon built-up on piston or combustion chamber

#### **Excessive smoke**

- Worn cylinder, piston or piston rings
- Improper installation of piston rings
- Scored or scratched piston or cylinder wall

#### **Abnormal noise (piston)**

- Worn piston pin or piston rings
- Worn cylinder, piston or piston ring
- Worn connecting rod small end

## CYLINDER REMOVAL

Remove the cylinder head (page 8-9).

*Rear cylinder only:* Remove the bolt and water hose joint.  
Remove the O-ring from the hose joint.

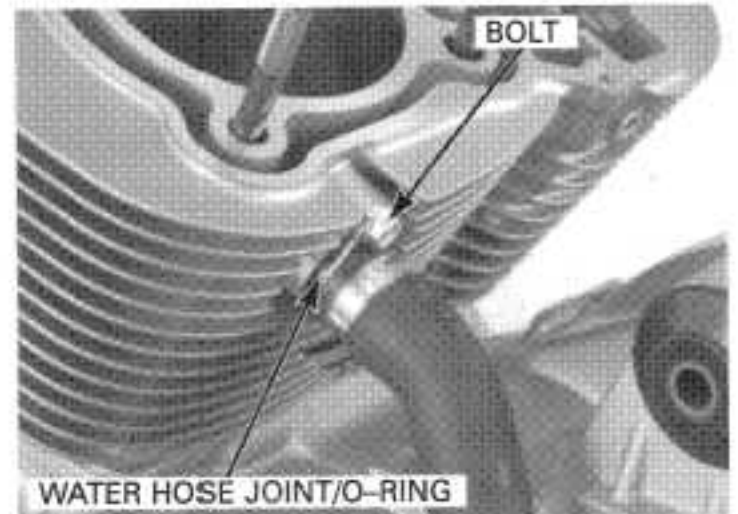

Remove the joint clips from the water joint pipe.  
While removing the cylinder, remove the water joint pipe.

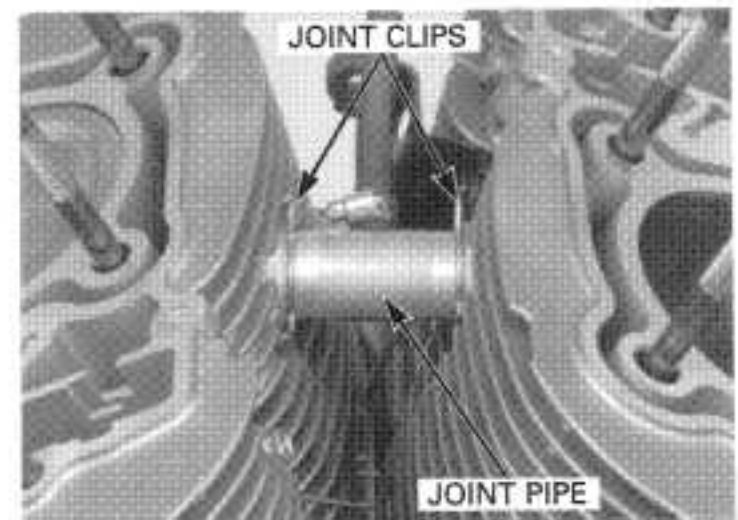

Remove the cylinder.

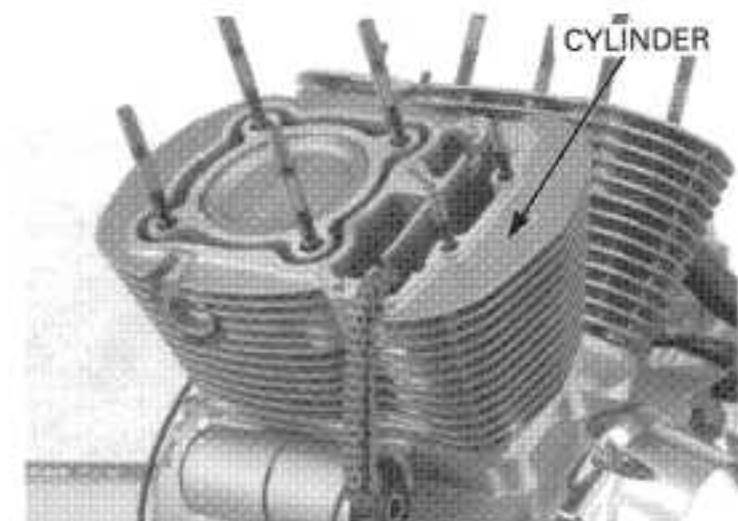

Remove the gasket and dowel pins.

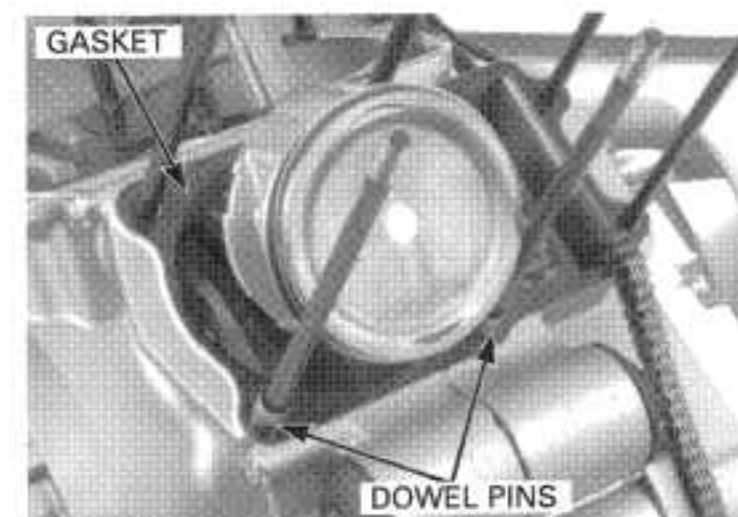

## CYLINDER/PISTON

Remove the reed valve from the crankcase.

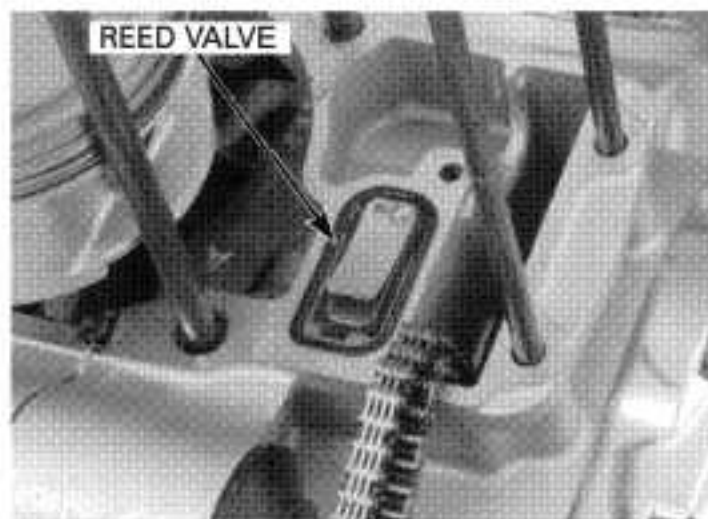

*The gasket will come off easier if it is soaked in solvent.*

Clean the top of each cylinder thoroughly to avoid damaging the gasket surfaces.

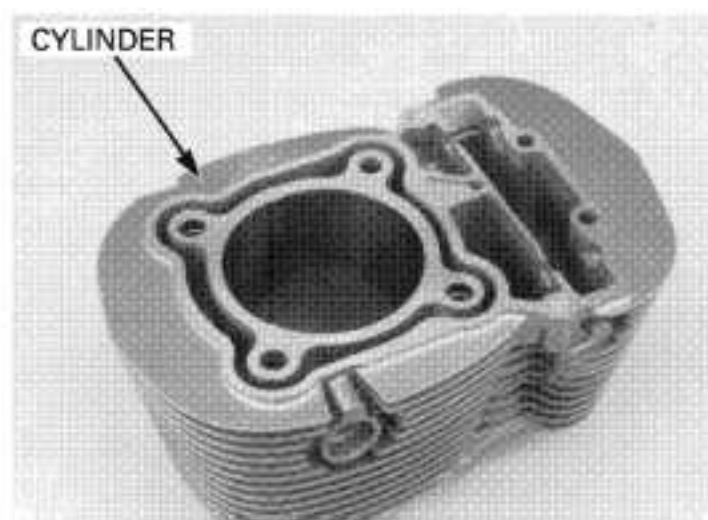

### INSPECTION

#### REED VALVE

Check the reed valve for damage or fatigue. Replace if necessary.

Replace the reed valve if the rubber seat is cracked, deteriorated or damaged, or if there is clearance between the reed and seat.

#### REED VALVE



#### RUBBER SEAT

#### CYLINDER

Check the cylinder for warpage by placing a straight edge and a feeler gauge across the stud holes as shown.

**SERVICE LIMIT: 0.10 mm (0.004 in)**

#### STRAIGHT EDGE

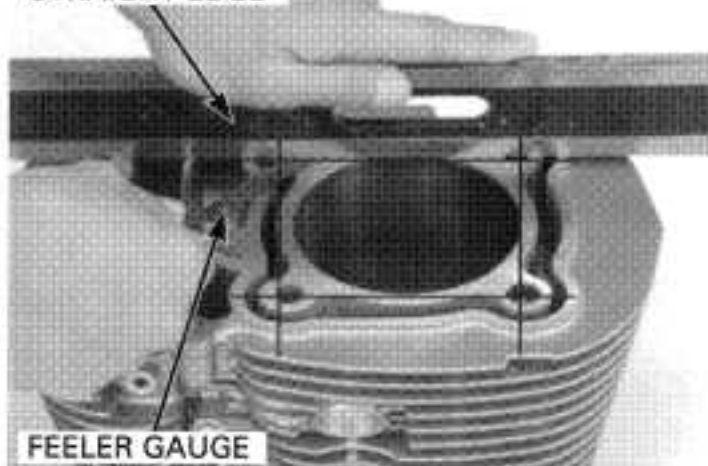

Inspect the cylinder bore for scratches or wear.  
 Measure the cylinder I.D. at three levels in the X and Y axes.  
 Take the maximum reading to determine the cylinder wear.

**SERVICE LIMIT: 101.05 mm (3.978 in)**

Calculate the cylinder for taper and out-of-round at three levels in the X and Y axes. Take the maximum reading to determine the taper and out-of-round.

**SERVICE LIMITS:**

**Taper: 0.10 mm (0.004 in)**

**Out-of-round: 0.10 mm (0.004 in)**

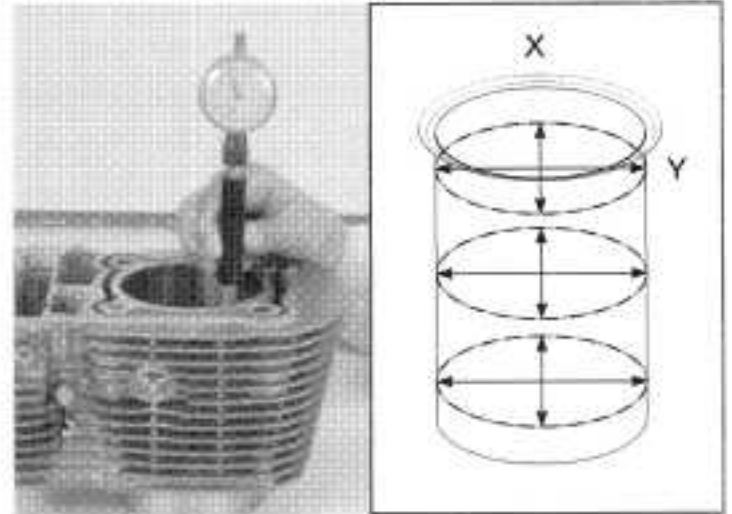

## PISTON REMOVAL

*Place a clean shop towel over the crankcase to prevent the clip from falling into the crankcase.*

*If you plan to reuse the piston, mark the piston with the cylinder and proper direction after removal so it can be placed back in its original location.*

Remove the piston pin clip using a pair of pliers.

Remove the piston pin and remove the piston.

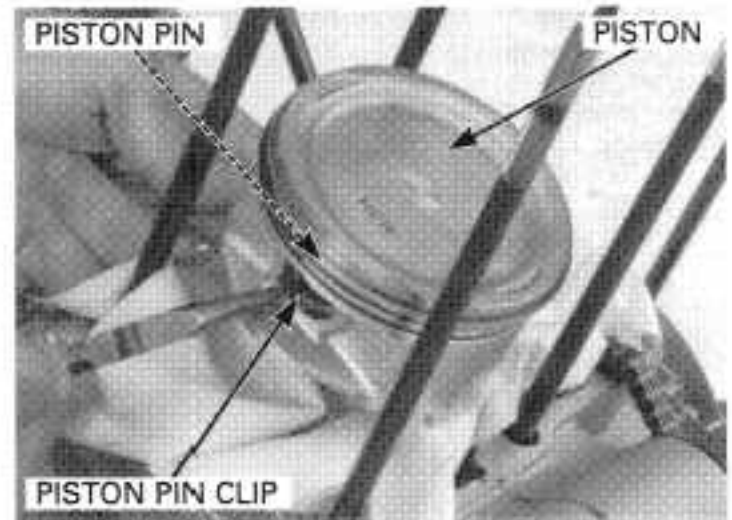

Remove the oil jet from the crankcase.

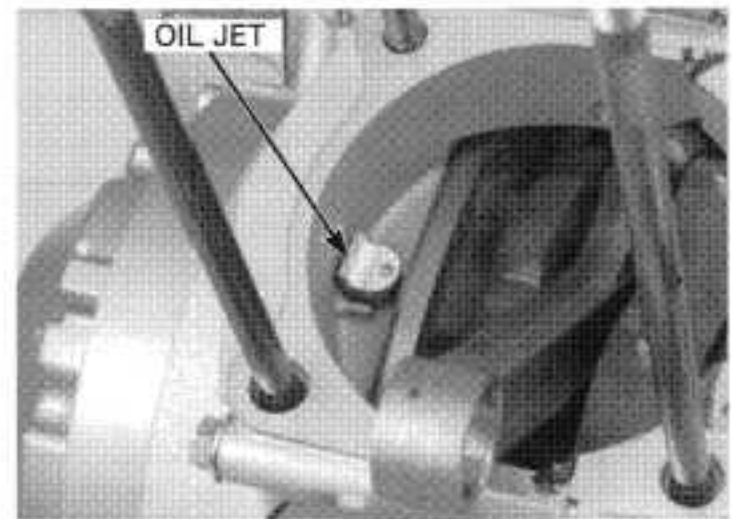

Check the oil jet for clogs.

Remove the O-ring from the oil jet.

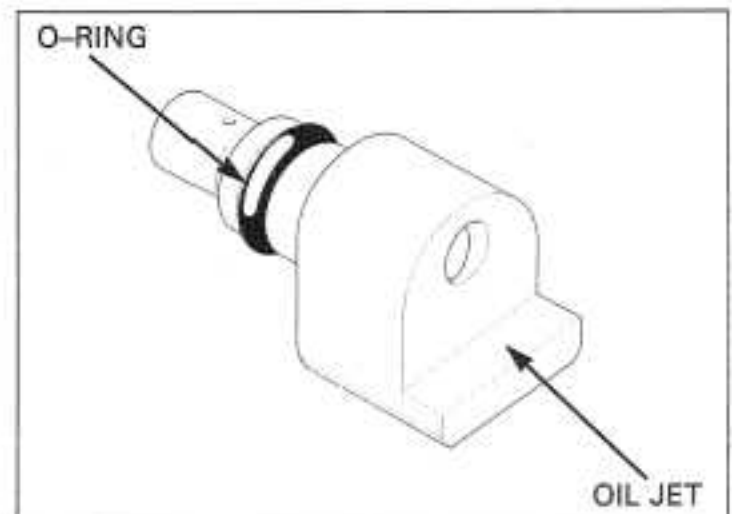



## CYLINDER/PISTON

Inspect the piston rings for smooth movement by rotating the rings. The rings should be able to move in their grooves without catching.

*Do not damage the piston ring by spreading the ends too far.*

Spread each piston ring and remove it by lifting it up at a point just opposite the gap.

*Clean carbon deposits from the ring grooves with a ring that will be discarded. Never use a wire brush; it will scratch the groove.*

Clean carbon deposits from the piston ring grooves.

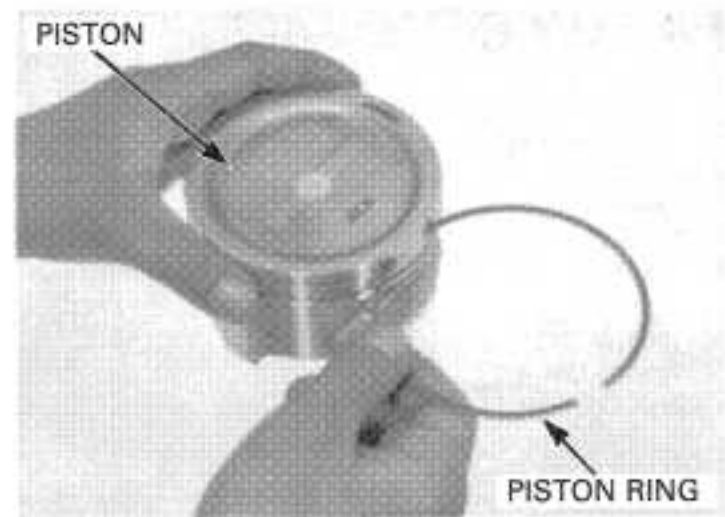
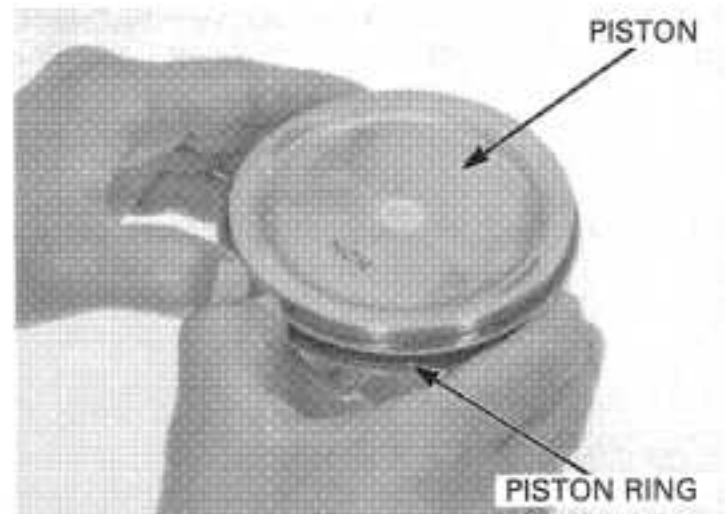

### PISTON/PISTON RING INSPECTION

Inspect the piston for wear or damage.

Measure the diameter of the piston at 18 mm (0.7 in) from the bottom and 90 degrees to the piston pin hole.

**SERVICE LIMIT: 100.91 mm (3.973 in)**

Calculate the cylinder-to-piston clearance (cylinder I.D.: see previous page).

**SERVICE LIMIT: 0.32 mm (0.126 in)**

Measure and record the piston pin hole I.D. in the X and Y axis. Take the maximum reading to determine the I.D.

**SERVICE LIMIT: 24.018 mm (0.9456 in)**

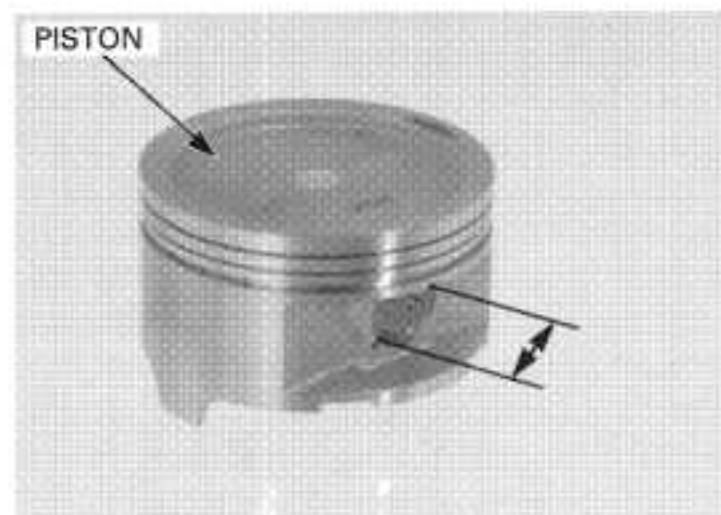
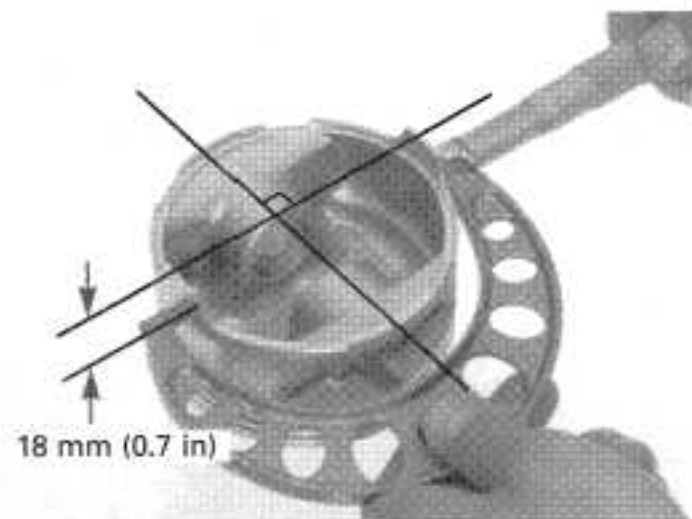

Measure and record the piston pin O.D. at three points.

**SERVICE LIMIT: 23.984 mm (0.9443 in)**

Calculate the piston-to-piston pin clearance by subtracting the piston pin O.D. from the piston pin hole I.D.

**SERVICE LIMIT: 0.034 mm (0.0013 in)**

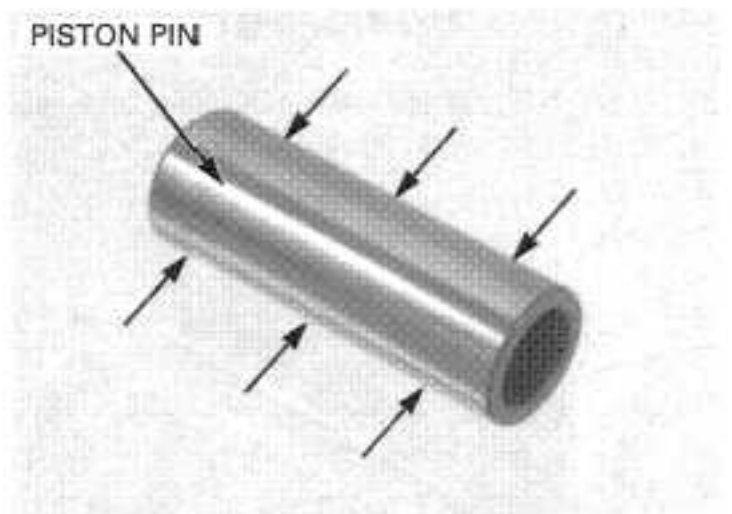

Measure and record the connecting rod small end I.D.

**SERVICE LIMIT: 24.051 mm (0.9469 in)**

Calculate the connecting rod-to-piston pin clearance by subtracting the piston pin O.D. from the small end I.D.

**SERVICE LIMIT: 0.07 mm (0.003 in)**

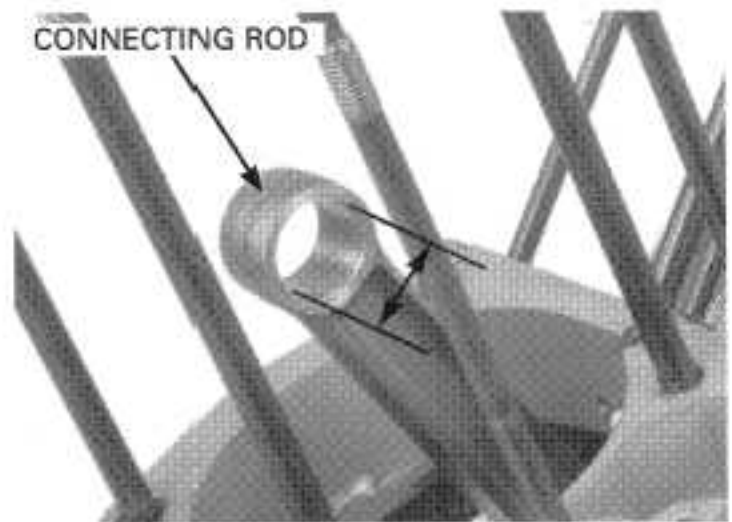

Temporarily install the piston rings to their proper position with the mark facing up.

Push the ring until the outer surface of the piston ring is nearly flush with the piston and measure the clearance using a feeler gauge.

**SERVICE LIMITS: Top: 0.07 mm (0.003 in)  
Second: 0.07 mm (0.003 in)**

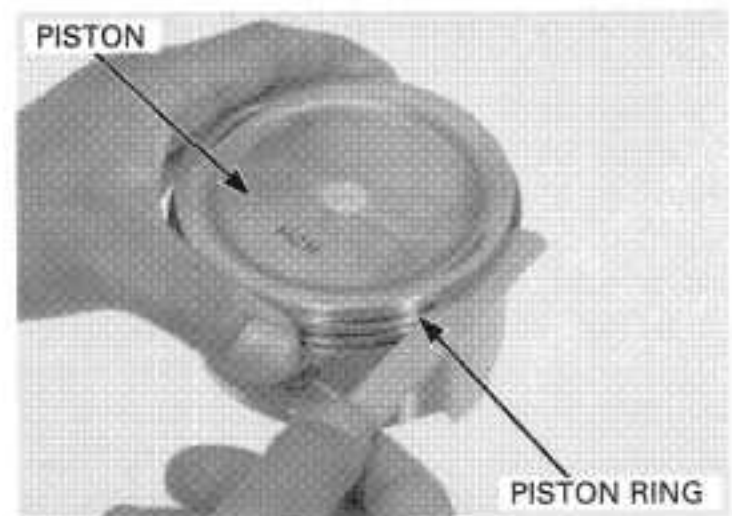

Insert the piston ring into the bottom of the cylinder squarely using the piston as shown.

Measure the end gap using a feeler gauge.

**SERVICE LIMITS: Top: 0.55 mm (0.022 in)  
Second: 0.70 mm (0.028 in)  
Oil: 0.90 mm (0.035 in)**

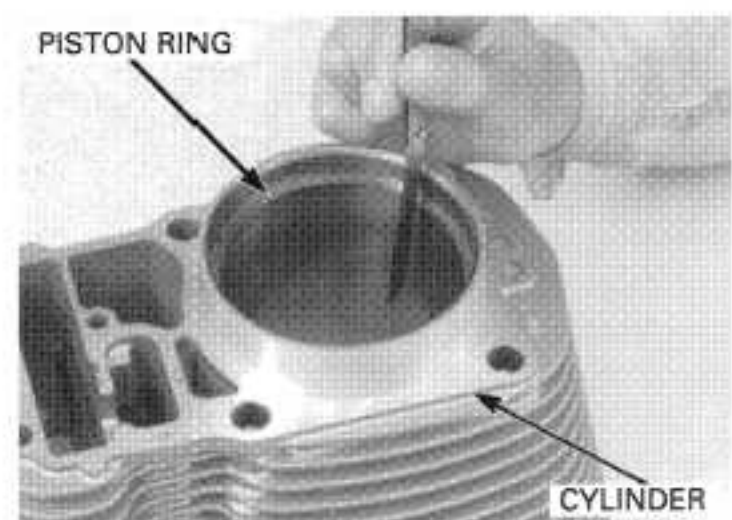

### CYLINDER STUD BOLT REPLACEMENT

If you will replace the stud bolts, remove them from the crankcase.

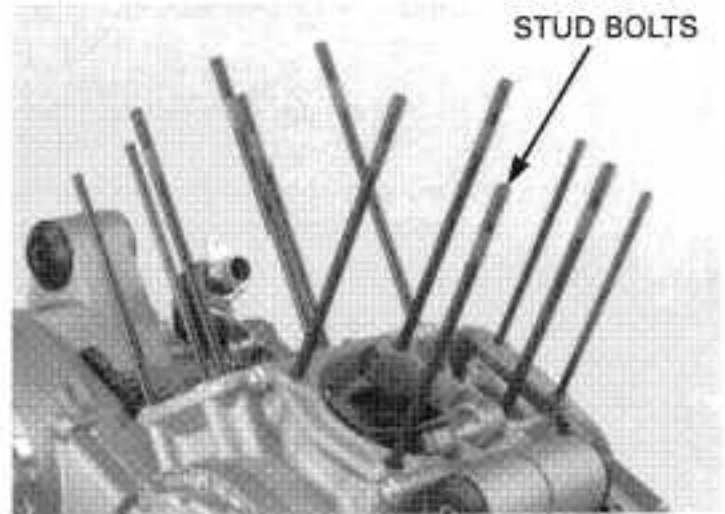

Apply engine oil to the stud bolt threads.  
Install the stud bolts.

After installation, be sure to measure the distance from the top of each stud to the crankcase surface as shown.

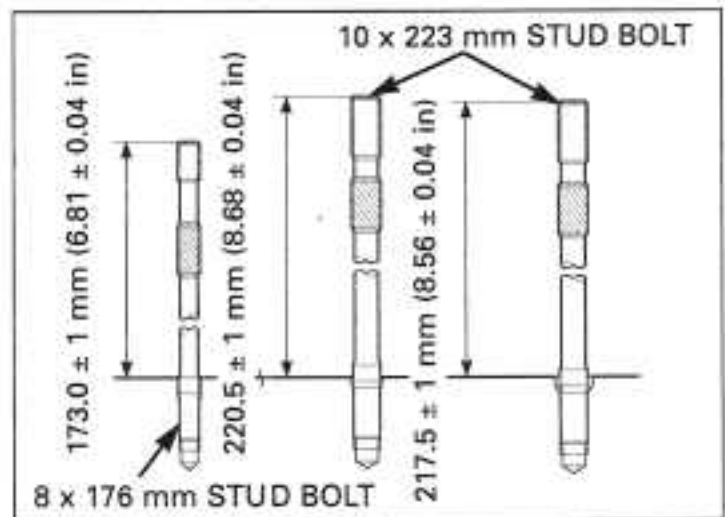

### PISTON RING INSTALLATION

Clean the piston head, ring lands and skirts.

Carefully install the piston rings onto the piston with the marks facing up.

**NOTE:**

- Do not confuse the top and second rings: the top ring is chrome-coated and the second ring is not coated (black).
- Be careful not to damage the piston and rings during assembly.
- To install the oil ring, install the spacer first, then install the side rails.
- Stagger the ring end gaps  $120^\circ$  as shown.

After installing the rings, check that they rotate freely without sticking.

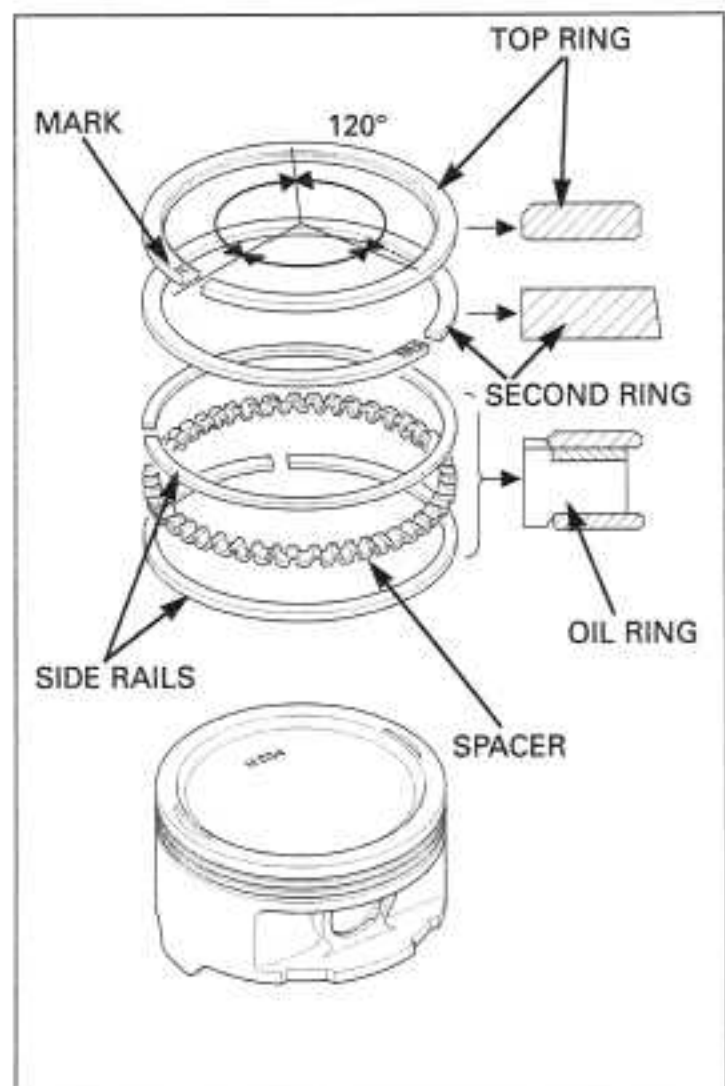

## PISTON INSTALLATION

Clean the gasket surface of the crankcase thoroughly, being careful not to damage it, and careful not to allow gasket material into the crankcase.

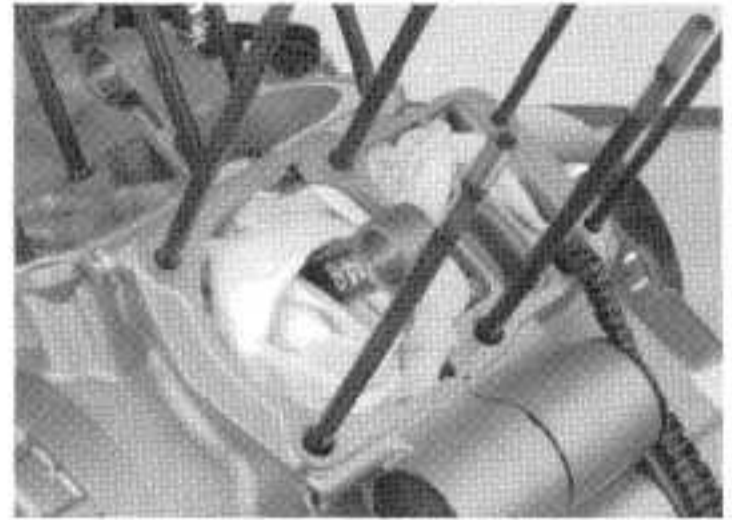

Apply engine oil to new O-rings and install one onto each oil jet.

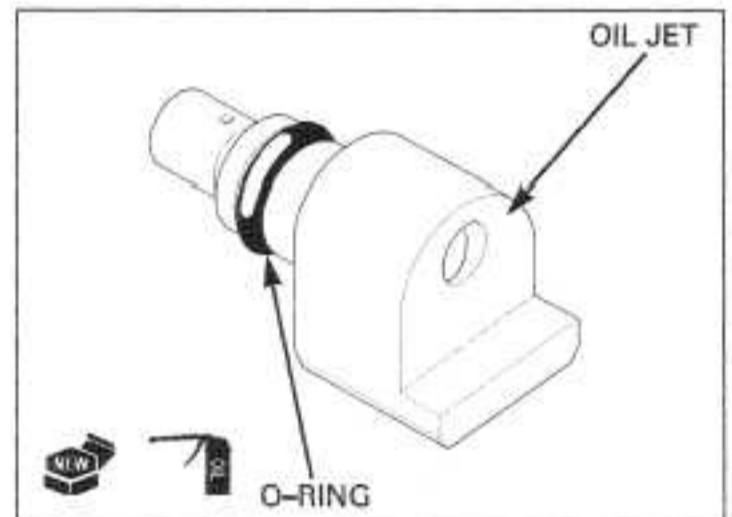

Install the oil jet into the crankcase properly as shown (jet hole side facing toward the connecting rod side).

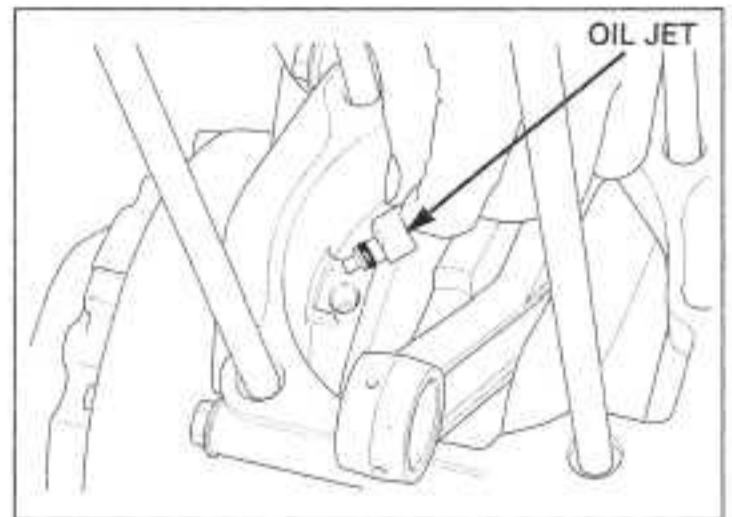

*Place a clean shop towel over the crankcase to prevent the clip from falling into the crankcase.*

Apply engine oil to the piston pin outer surface. Set the piston over the connecting rod with the piston direction and position properly as noted during removal.

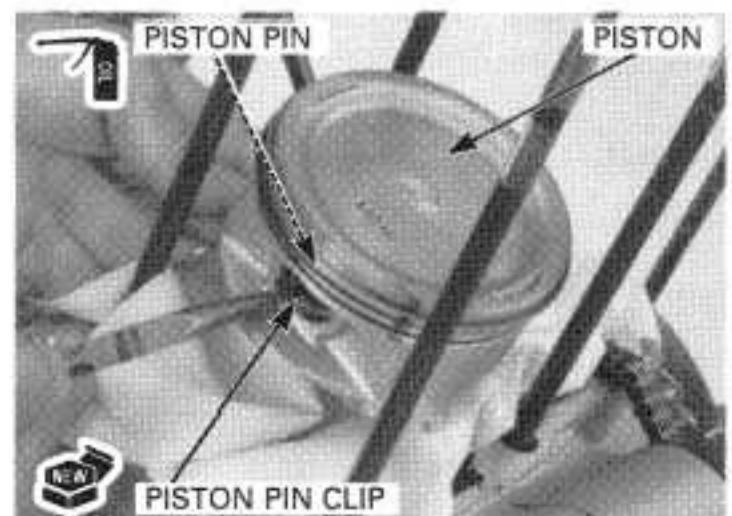

*Make sure the piston pin clips are seated properly and their end gaps are not aligned with the cutouts in the piston.*

Install new piston pin clips.



## CYLINDER INSTALLATION

Install the reed valve into the crankcase securely as shown.

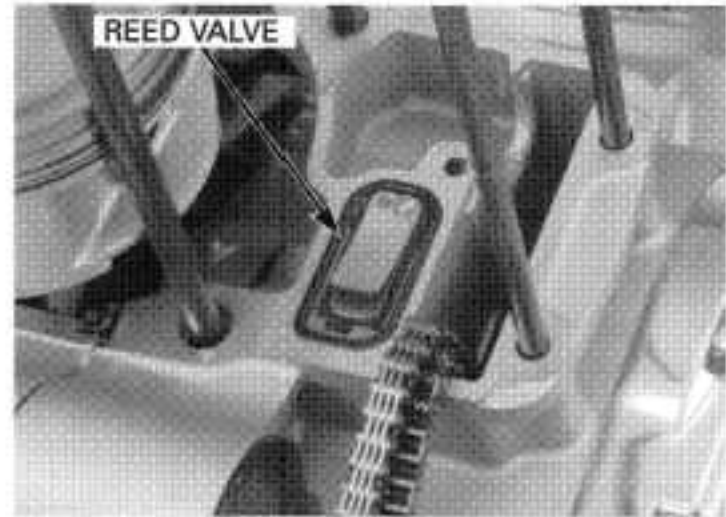

Install a new gasket and the dowel pins.

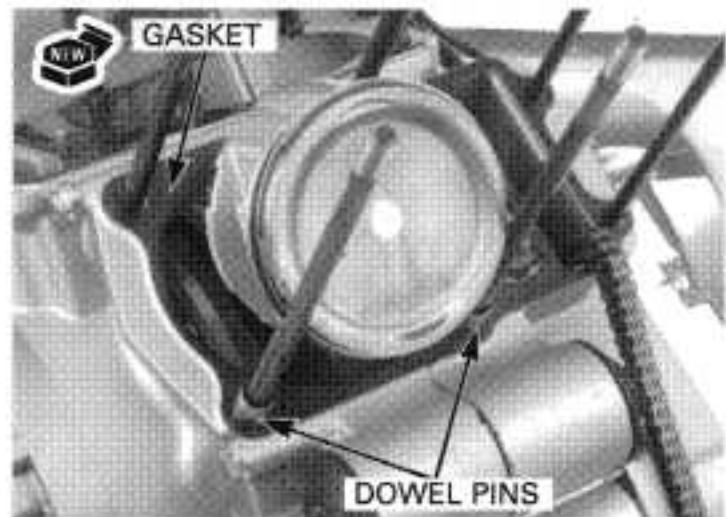

The cylinders have the following identification marks:  
"F": Front cylinder  
"R": Rear cylinder

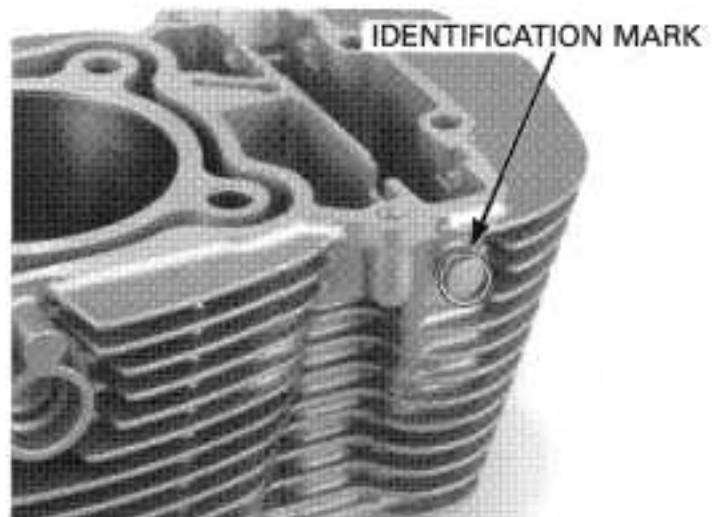

Apply engine oil to the cylinder wall, piston and piston ring outer surfaces.

*Be careful not to damage the piston rings and cylinder wall.*

Route the cam chain through the cylinder and install the cylinder over the piston while compressing the piston rings with your fingers.

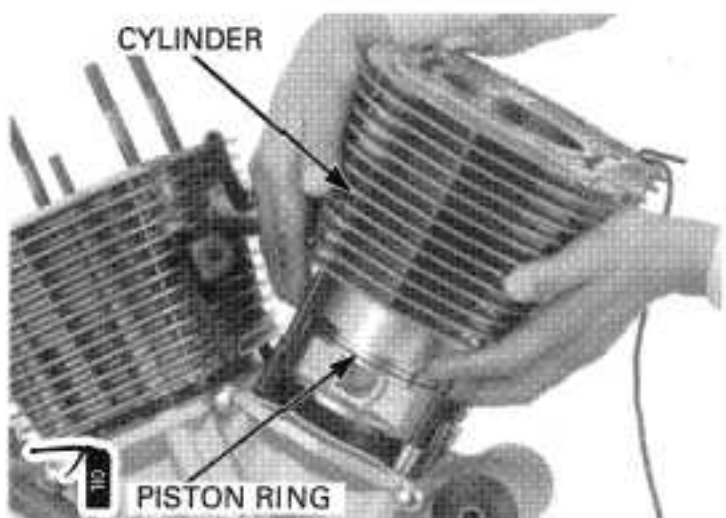



*If water joint pipe installation is difficult, raise one of the cylinders and install the pipe. Then carefully lower the cylinder and install the other side of the pipe into the other cylinder.*

Coat new O-rings with coolant and install them into the end grooves in the water joint pipe and into the cylinders.

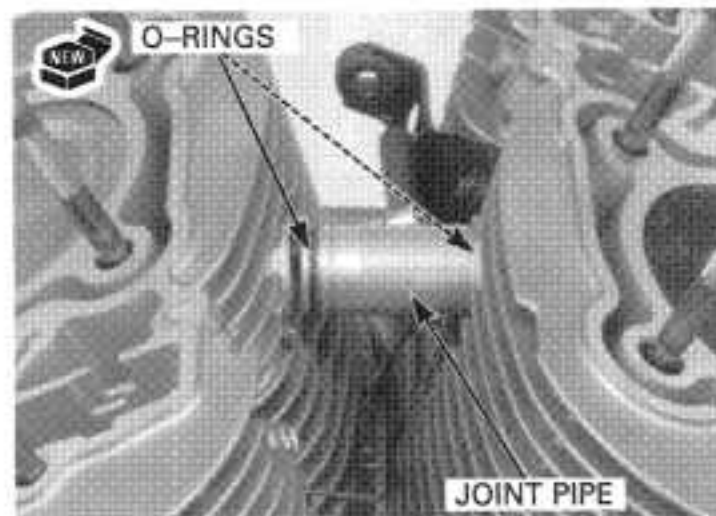

Slide the water joint pipe in position between the cylinders. Install the joint clips in the joint grooves.

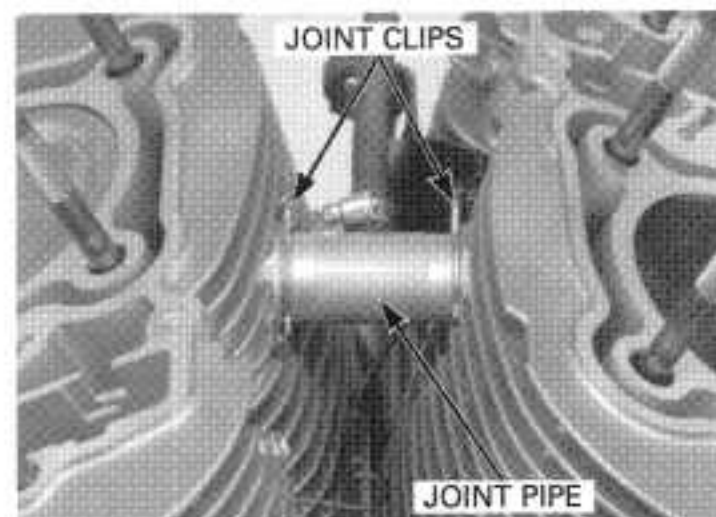

*Rear cylinder only:*

Coat a new O-ring with coolant and install it in the water hose joint groove of the rear cylinder.

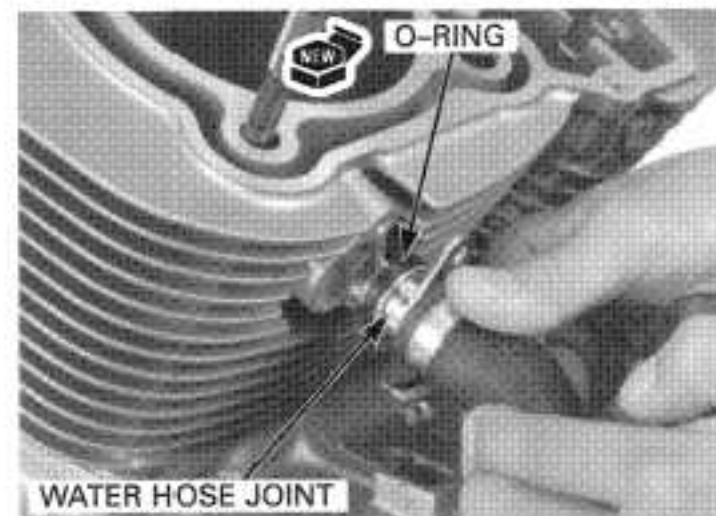

Install and tighten the bolts securely.  
Install the cylinder head (page 8-19).

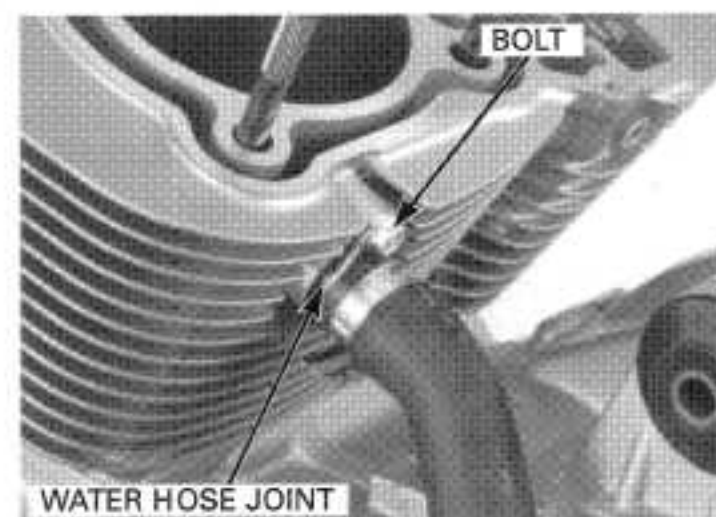

# CLUTCH/GEARSHIFT LINKAGE

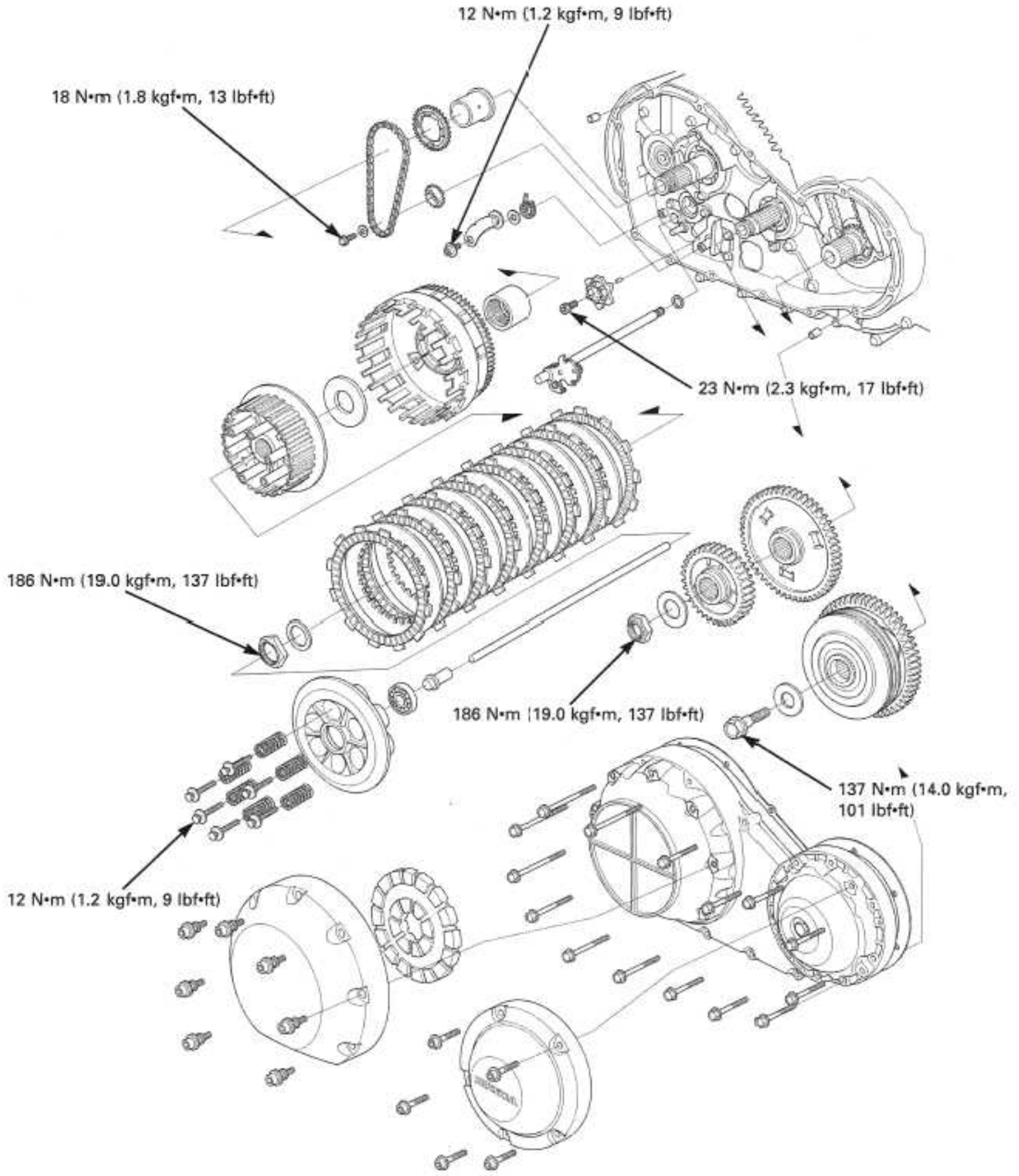

# 10. CLUTCH/GEARSHIFT LINKAGE

SERVICE INFORMATION	10-2	RIGHT CRANKCASE COVER	10-13
TROUBLESHOOTING	10-3	CLUTCH	10-15
CLUTCH FLUID REPLACEMENT/ AIR BLEEDING	10-4	PRIMARY DRIVE GEAR	10-24
CLUTCH MASTER CYLINDER	10-6	PRIMARY DRIVEN GEARS	10-25
CLUTCH SLAVE CYLINDER	10-11	GEARSHIFT LINKAGE	10-28

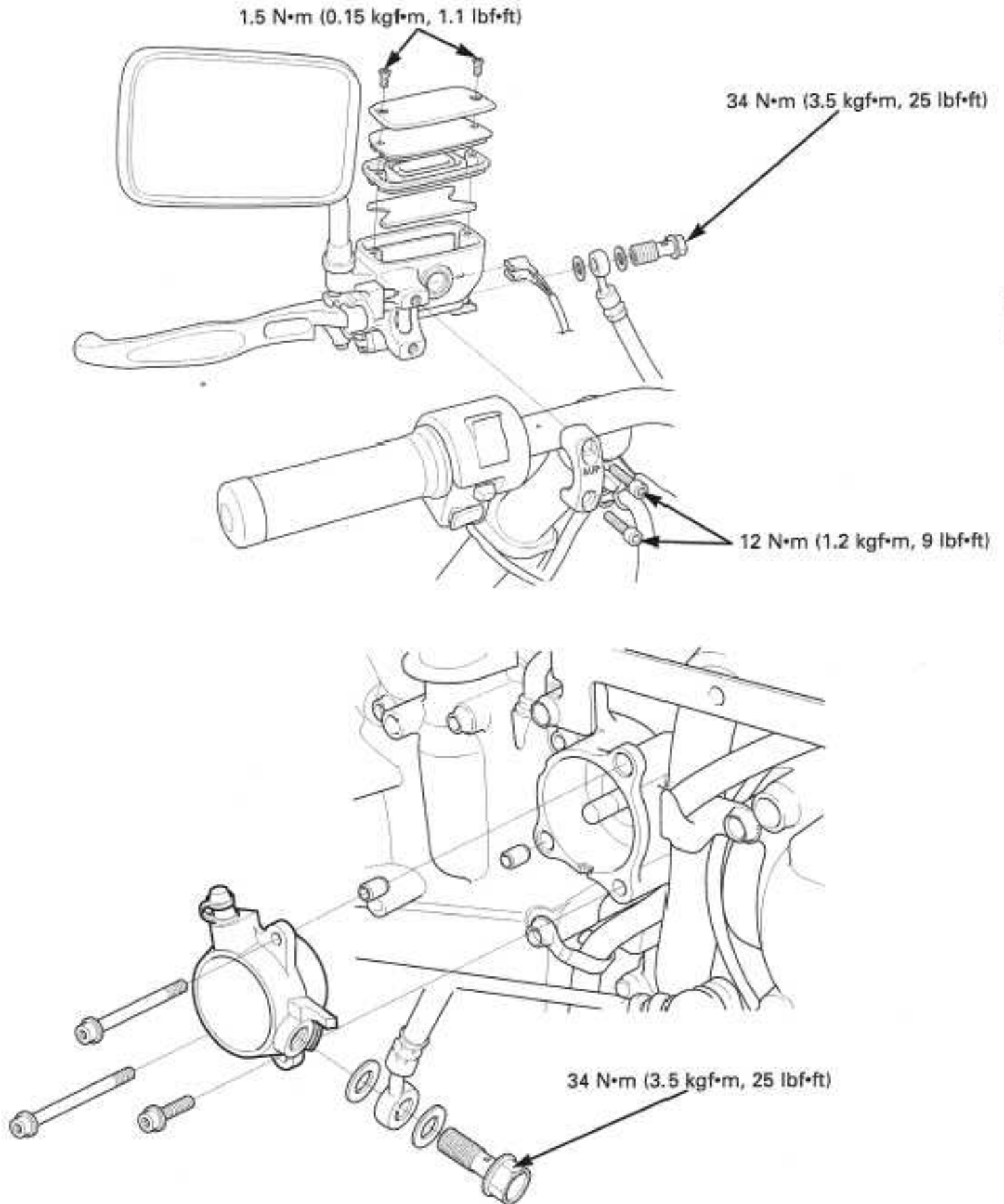

## CLUTCH/GEARSHIFT LINKAGE

### SERVICE INFORMATION

#### GENERAL

- This section covers service of the clutch and gearshift linkage. All service can be done with the engine installed in the frame.
- Spilled brake fluid will severely damage instrument lenses and painted surfaces. It is also harmful to some rubber parts. Be careful whenever you remove the reservoir cap; make sure the clutch reservoir is horizontal.
- Never allow contaminants (e.g., dirt, water) to get into an open reservoir.
- Once the hydraulic system has been opened, or if the clutch lever feels spongy, the system must be bled.
- Always use fresh DOT 4 brake fluid from a sealed container when servicing the system. Do not mix different types of fluid, they may not be compatible.
- Engine oil viscosity, level and the use of oil additives have an effect on clutch disengagement. Oil additives of any kind are specifically not recommended. When the clutch does not disengage or the motorcycle creeps with the clutch disengaged, inspect the engine oil viscosity and level before servicing the clutch system.
- The crankcase must be separated when the transmission, shift drum and shift forks require service (section 11).

#### SPECIFICATION

Unit: mm (in)

ITEM		STANDARD	SERVICE LIMIT
Recommended clutch fluid		DOT 4 brake fluid	—
Clutch master cylinder	Cylinder I.D.	12.700 – 12.743 (0.5000 – 0.5017)	12.76 (0.502)
	Piston O.D.	12.657 – 12.684 (0.4983 – 0.4994)	12.65 (0.498)
Clutch	Spring free length	58.2 (2.29)	56.7 (2.23)
	Disc thickness	3.72 – 3.88 (0.146 – 0.153)	3.1 (0.12)
	Plate warpage	—	0.30 (0.012)
Clutch outer guide I.D.		27.995 – 28.012 (1.1022 – 1.1028)	28.8 (1.106)
Mainshaft O.D. at clutch outer guide		27.980 – 27.993 (1.1016 – 1.1021)	27.970 (1.1012)

#### TORQUE VALUES

Clutch lifter plate bolt	12 N•m (1.2 kgf•m, 9 lbf•ft)	
Clutch center lock nut	186 N•m (19.0 kgf•m, 137 lbf•ft)	Stake. Apply oil to the threads and flange surface.
Primary drive gear bolt	137 N•m (14.0 kgf•m, 101 lbf•ft)	Apply oil to the threads and flange surface.
Primary driven gear nut	186 N•m (19.0 kgf•m, 137 lbf•ft)	Stake. Apply oil to the threads and flange surface.
Shift drum stopper arm bolt	12 N•m (1.2 kgf•m, 9 lbf•ft)	
Shift drum center socket bolt	23 N•m (2.3 kgf•m, 17 lbf•ft)	Apply a locking agent to the threads.
Shift return spring pin	23 N•m (2.3 kgf•m, 17 lbf•ft)	
Change pedal pinch bolt	12 N•m (1.2 kgf•m, 9 lbf•ft)	
Clutch master cylinder holder bolt	12 N•m (1.2 kgf•m, 9 lbf•ft)	
Clutch master cylinder reservoir cap screw	1.5 N•m (0.15 kgf•m, 1.1 lbf•ft)	
Clutch lever pivot bolt	1 N•m (0.1 kgf•m, 0.7 lbf•ft)	
Clutch lever pivot nut	6 N•m (0.6 kgf•m, 4.3 lbf•ft)	
Clutch switch screw	1.2 N•m (0.12 kgf•m, 0.9 lbf•ft)	
Clutch hose oil bolt	34 N•m (3.5 kgf•m, 25 lbf•ft)	
Slave cylinder bleed valve	6 N•m (0.6 kgf•m, 4.3 lbf•ft)	
Oil pump driven sprocket bolt	18 N•m (1.8 kgf•m, 13 lbf•ft)	Apply a locking agent to the threads.

**TOOLS**

Gear holder	07724-0010100 not available in U.S.A.
Attachment, 32 x 35 mm	07746-0010100
Pilot, 17 mm	07746-0040400
Driver	07749-0010000
Snap ring pliers	07914-SA50001
Holder plate	07HGB-001010B or 07HGB-001010A and
Holder collar "A"	07HGB-001020B or 07HGB-001020A

**TROUBLESHOOTING****Clutch lever soft or spongy**

- Air in hydraulic system
- Low fluid level
- Hydraulic system leaking

**Clutch lever too hard to pull in**

- Sticking master cylinder piston
- Sticking slave cylinder
- Clogged hydraulic system
- Damaged clutch lifter mechanism
- Faulty clutch lifter bearing
- Clutch lifter piece installed improperly

**Clutch slips**

- Hydraulic system sticking
- Worn clutch discs
- Weak clutch springs
- Engine oil level too low or oil additive used

**Clutch will not disengage or motorcycle creeps with clutch disengaged**

- Air in hydraulic system
- Low fluid level
- Hydraulic system leaking or clogged
- Clutch plate warped
- Loose clutch lock nut
- Engine oil level too high
- Improper engine oil viscosity
- Damaged clutch lifter mechanism
- Clutch lifter piece installed improperly



### CLUTCH FLUID REPLACEMENT/AIR BLEEDING

#### CLUTCH FLUID DRAINING

*Do not allow foreign material to enter the system when filling the reservoir.*

Turn the handlebar to the right until the reservoir is parallel to the ground, before removing the reservoir cap.

Remove the screws, reservoir cap, set plate, diaphragm and float.

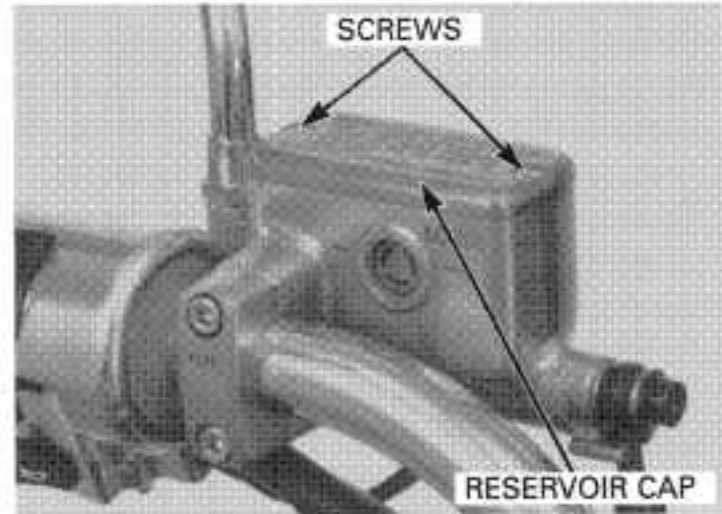

Connect the bleed hose to the bleed valve. Loosen the bleed valve and pump the clutch lever until fluid stops flowing out of the bleed valve.

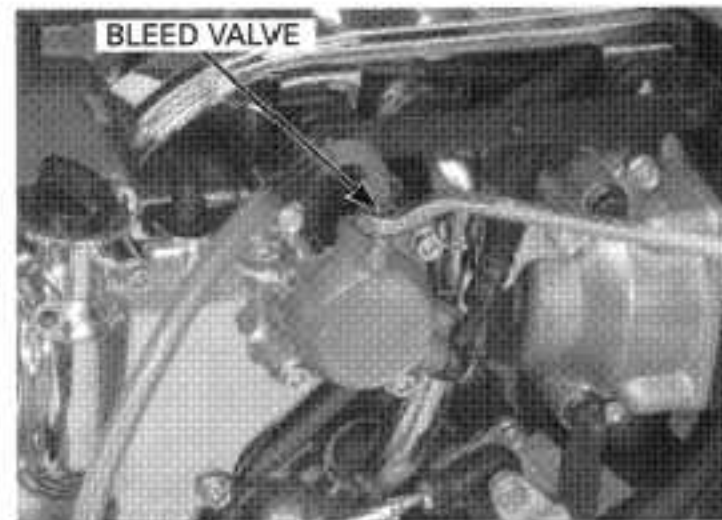

#### CLUTCH FLUID FILLING/AIR BLEEDING

*Use only DOT 4 brake fluid from a sealed container.*

*Do not mix different types of fluid. They are not compatible.*

Fill the reservoir with DOT 4 brake fluid from a sealed container.

Connect a commercially available brake bleeder to the bleed valve.

Pump the brake bleeder and loosen the bleed valve, adding fluid when the fluid level in the reservoir is low.

- Check the fluid level often while bleeding the clutch to prevent air from being pumped into the system.
- When using a brake bleeding tool, follow the manufacturer's operating instructions.

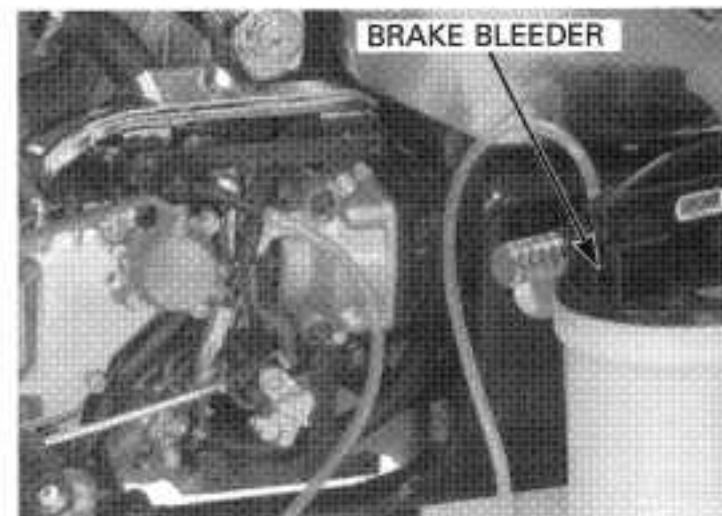

*If air is entering the bleeder from around the bleed valve threads, seal the threads with teflon tape.*

Repeat the previous procedures until air bubbles do not appear in the plastic hose.

Close the bleed valve and operate the clutch lever. If it is still spongy, bleed the system again.

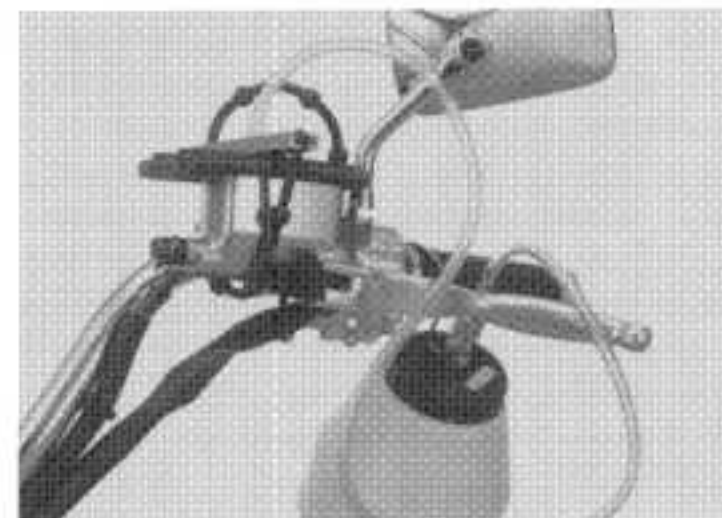

If a brake bleeder is not available, use the following procedure:

Connect a plastic hose to the bleed valve and place the other end of the hose in a container.

Loosen the bleed valve 1/4 of a turn and pump the clutch lever until the fluid flows out from the bleed valve.

1. Pump the clutch lever several times, then squeeze the clutch lever all the way and loosen the bleed valve 1/4 of a turn. Wait several seconds and close the bleed valve.  
Do not release the clutch lever until the bleed valve has been closed.
2. Release the clutch lever slowly after the bleed valve has been closed.

Repeat steps one and two until air bubbles do not appear in the bleed hose.

Tighten the bleed valve to the specified torque.

**TORQUE: 6 N·m (0.6 kgf·m, 4.3 lbf·ft)**

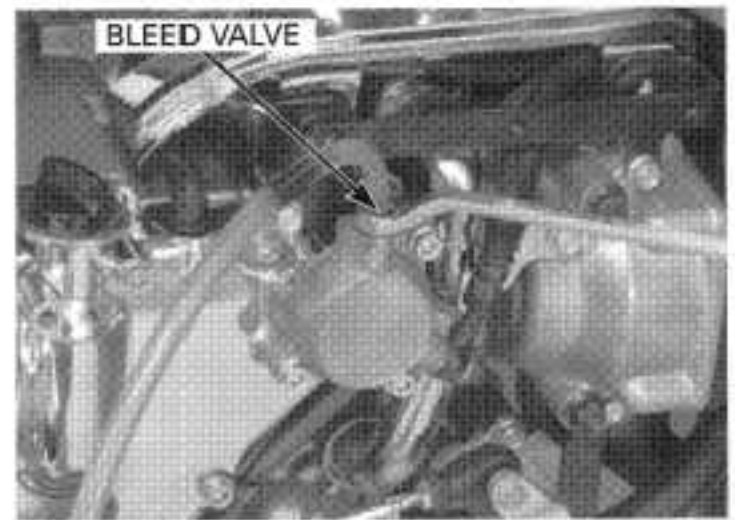
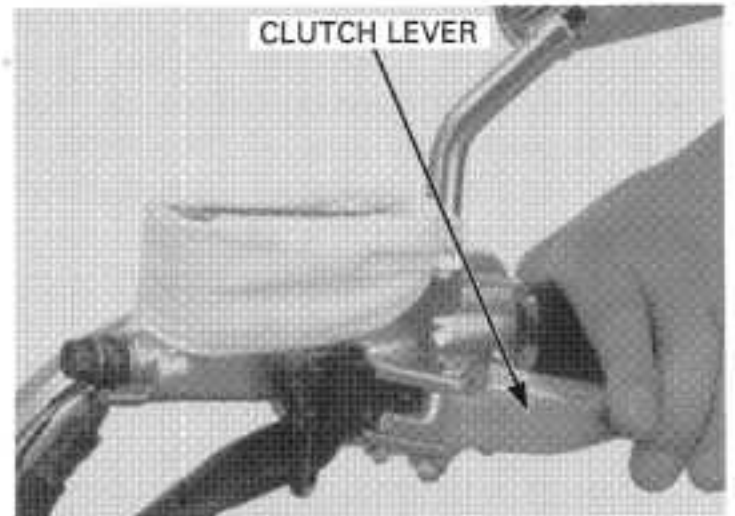

Fill the reservoir to the upper level line with DOT 4 brake fluid.

Install the float, diaphragm, set plate and reservoir cap.

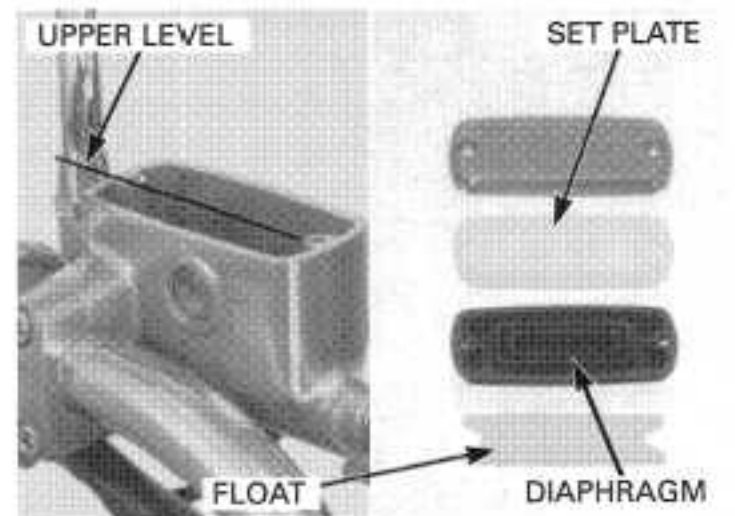

Tighten the reservoir cap screws to the specified torque.

**TORQUE: 1.5 N·m (0.15 kgf·m, 1.1 lbf·ft)**

Check the clutch operation (page 3-21).

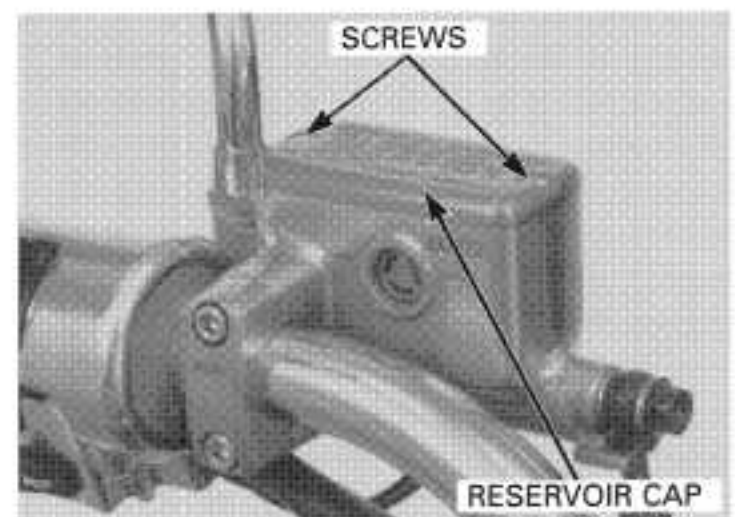

**CLUTCH MASTER CYLINDER**

**REMOVAL**

Drain the clutch fluid from the hydraulic system (page 10-4).

Remove the left rearview mirror.

Disconnect the clutch switch connectors.

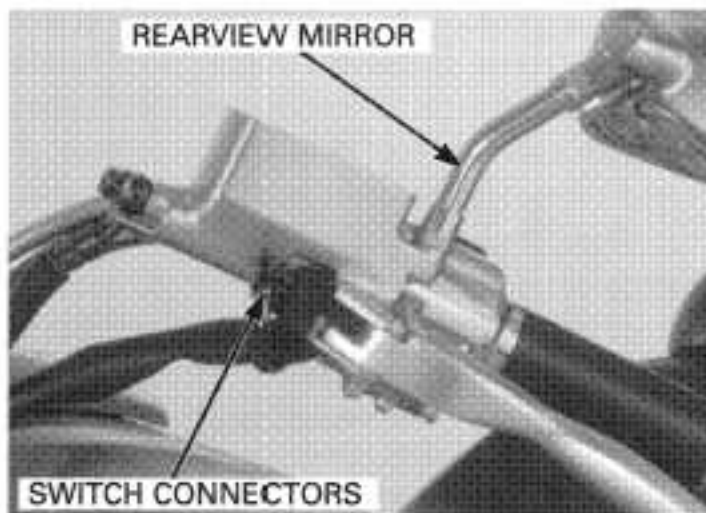

*When removing the oil bolt, cover the end of the hose to prevent contaminations.*

Remove the clutch hose oil bolt, sealing washers and clutch hose.

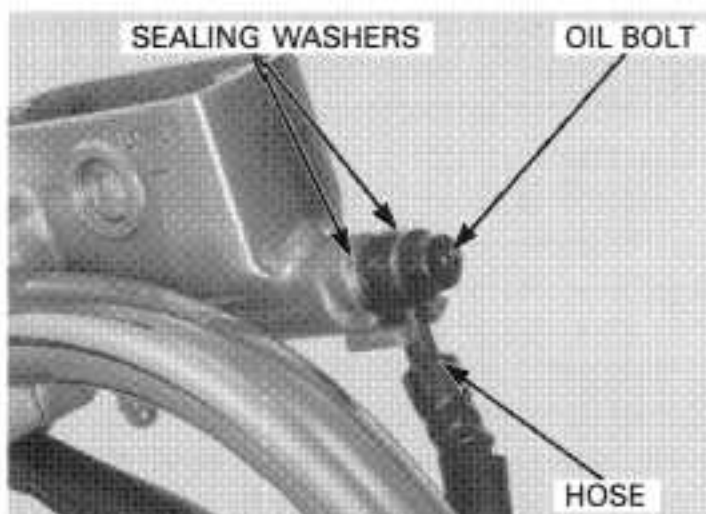

Remove the bolts, holder and clutch master cylinder assembly.

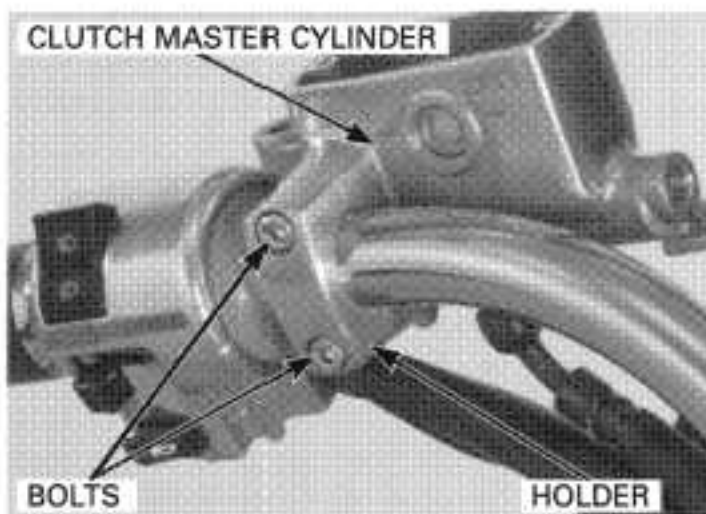

**DISASSEMBLY**

Remove the pivot nut, bolt and clutch lever assembly.

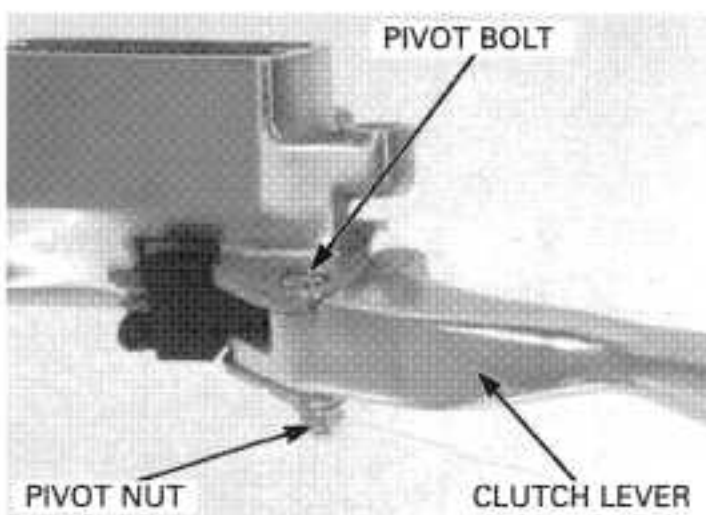

Remove the screw and clutch switch.

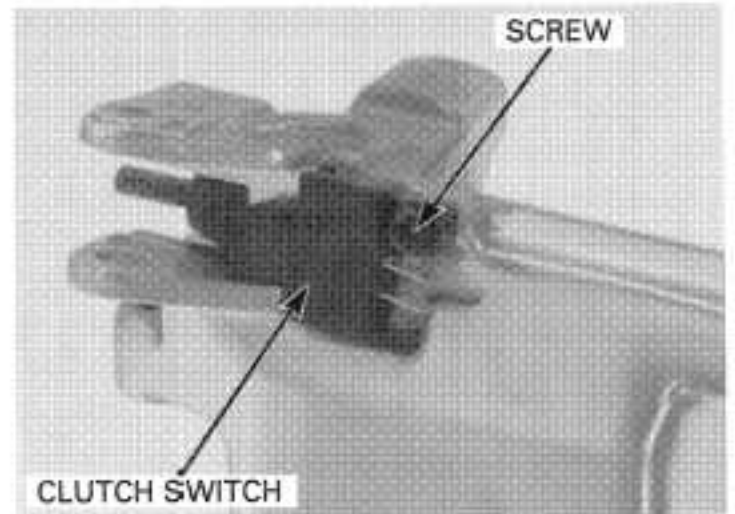

Remove the boot and push rod.

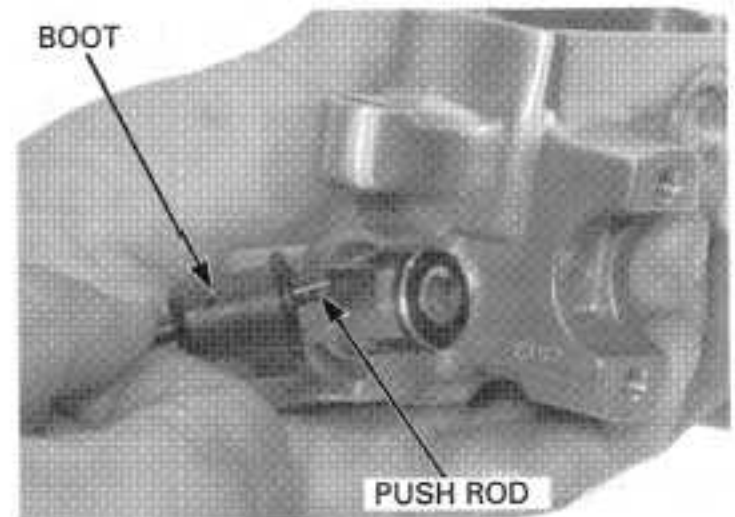

Remove the snap ring from the master cylinder body using the specified tool.

**TOOL:**  
Snap ring pliers                      07914-SA50001

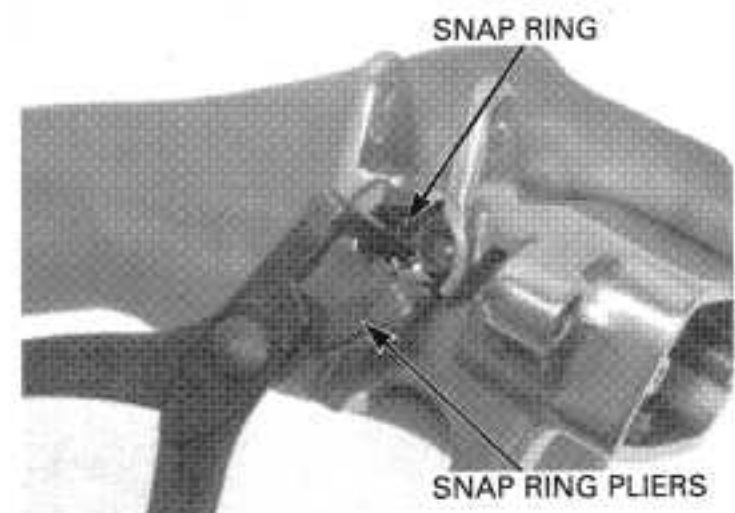

Remove the master piston and spring.

Clean the inside of the cylinder and reservoir with clean brake fluid.

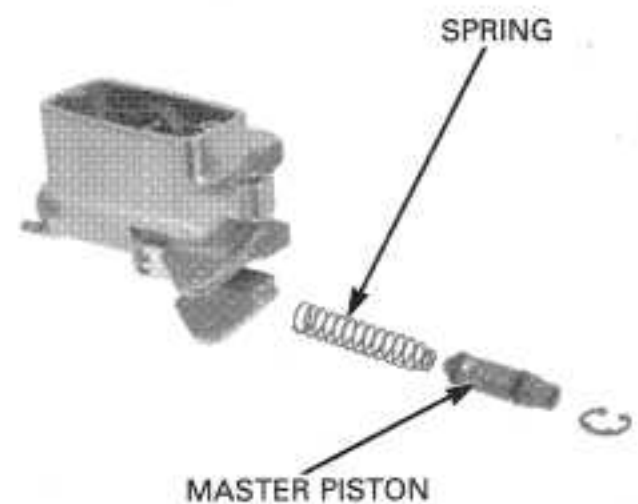



## CLUTCH/GEARSHIFT LINKAGE

### INSPECTION

Check the piston boot, primary cup and secondary cup for fatigue or damage.  
Check the master cylinder and piston for abnormal scratches.

Measure the master cylinder I.D.

**SERVICE LIMIT: 12.76 mm (0.502 in)**

Measure the master piston O.D.

**SERVICE LIMIT: 12.65 mm (0.498 in)**

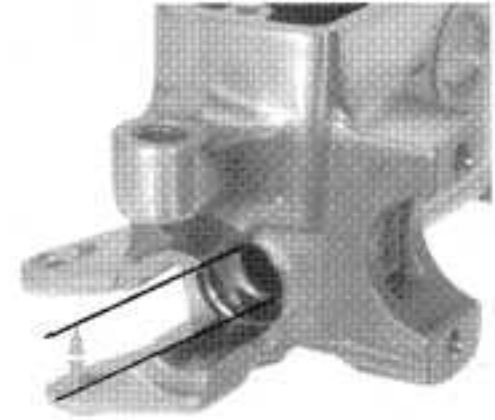

### ASSEMBLY

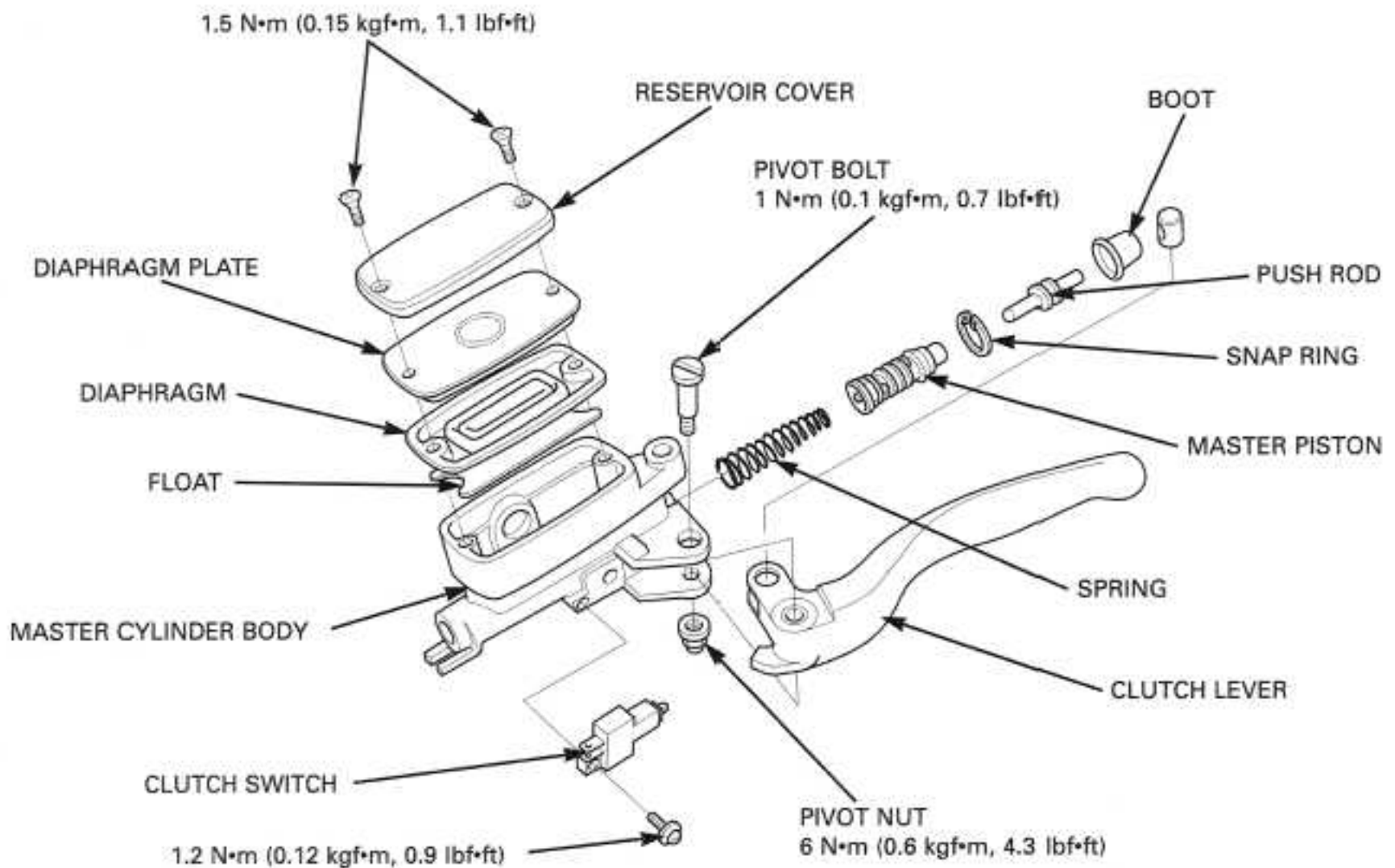



*Do not allow the piston cup lips to turn inside out.*

Coat all parts with clean DOT 4 brake fluid.  
Dip the piston in the brake fluid.  
Install the spring into the master cylinder.  
Install the piston assembly into the master cylinder.

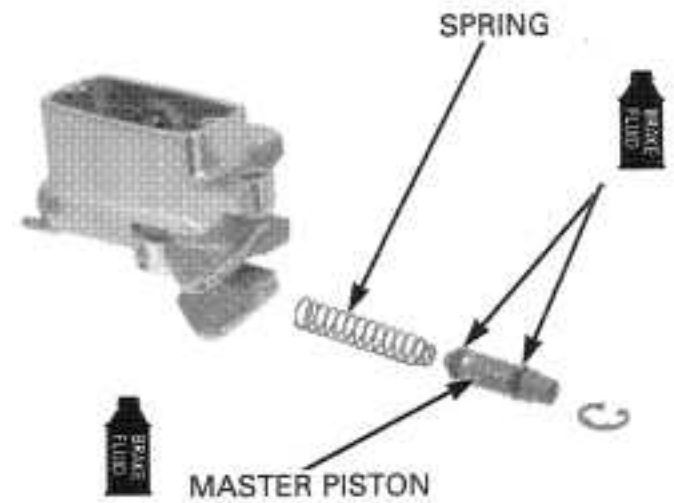

Install the snap ring into the groove in the master cylinder.

**TOOL:**  
Snap ring pliers                      07914-SA50001

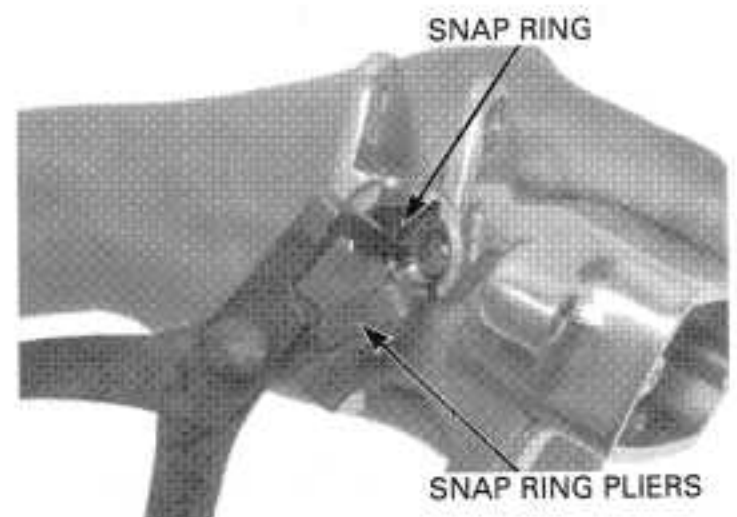

Apply silicone grease to the inside of the boot and the tip of the push rod.  
Install the push rod and boot.

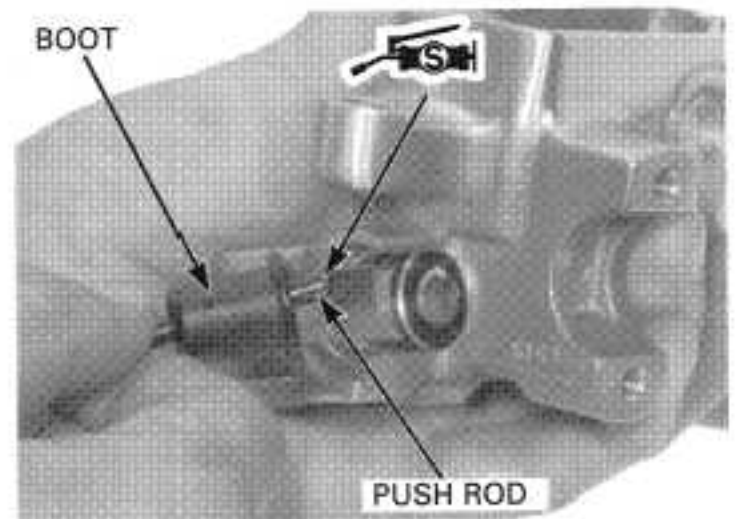

Install the clutch switch and tighten the screw to the specified torque.

**TORQUE:** 1.2 N·m (0.12 kgf·m, 0.9 lbf·ft)

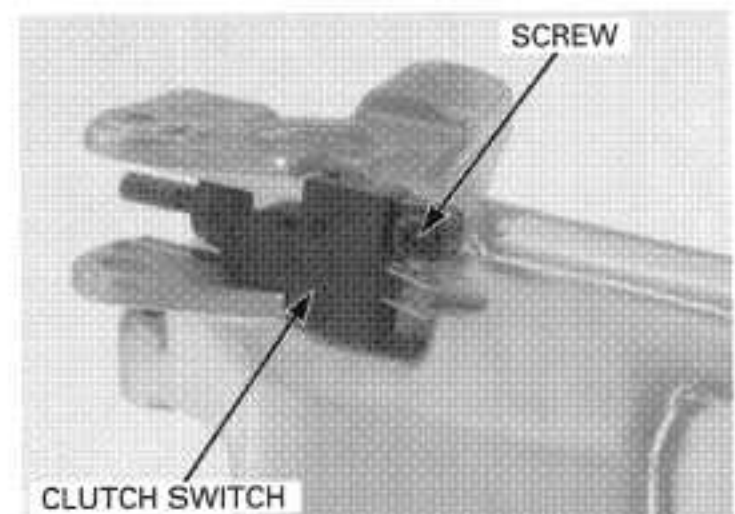

## CLUTCH/GEARSHIFT LINKAGE

Apply silicone grease to the tip of the push rod, then install the clutch lever.

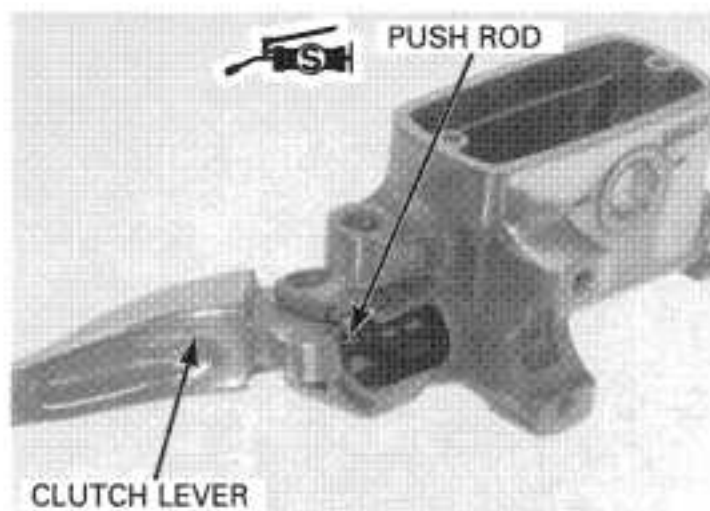

Apply silicone grease to the pivot bolt. Install and tighten the pivot bolt to the specified torque.

**TORQUE: 1 N·m (0.1 kgf·m, 0.7 lbf·ft)**

Hold the pivot bolt and tighten the pivot nut to the specified torque.

**TORQUE: 6 N·m (0.6 kgf·m, 4.3 lbf·ft)**

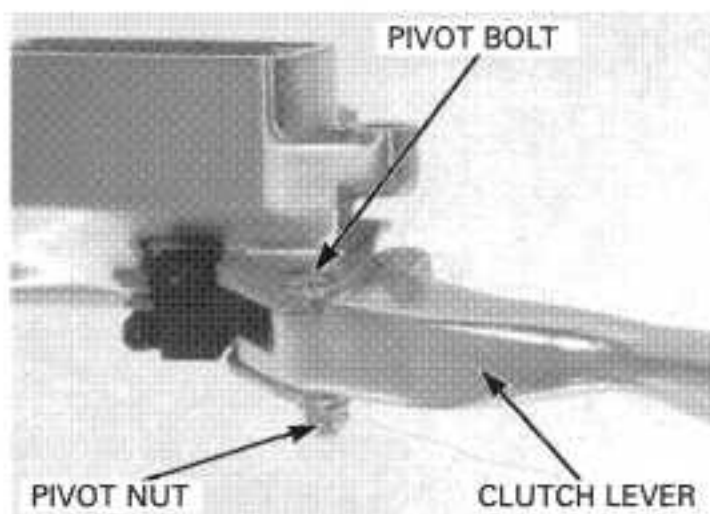

## INSTALLATION

Place the master cylinder assembly on the handlebar. Align the end of the master cylinder with the punch mark on the handlebar.

Install the master cylinder holder with the "UP" mark facing up. Tighten the upper bolt first, then the lower bolt.

**TORQUE: 12 N·m (1.2 kgf·m, 9 lbf·ft)**

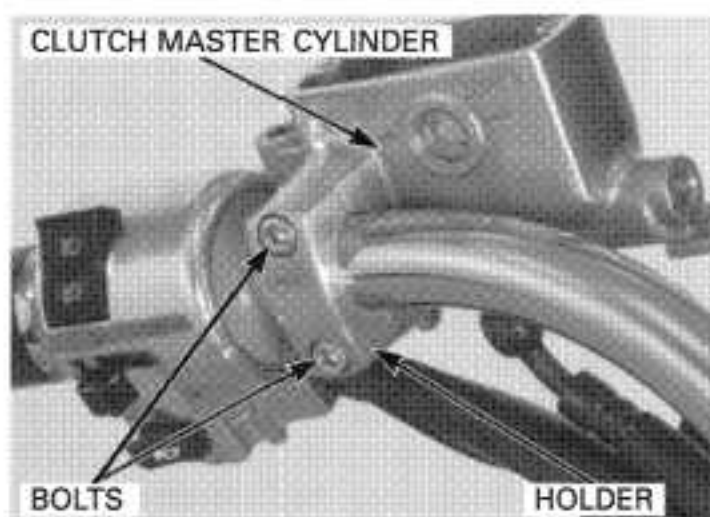

Connect the clutch hose to the master cylinder with the clutch hose oil bolt and new sealing washers. While pushing the clutch hose against the stopper, tighten the clutch hose oil bolt to the specified torque.

**TORQUE: 34 N·m (3.5 kgf·m, 25 lbf·ft)**

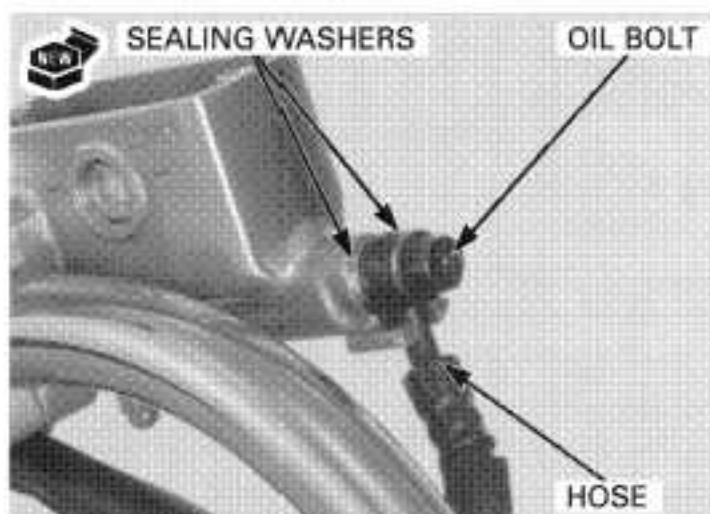

Connect the clutch switch connectors.  
Install the rearview mirror.

Fill the reservoir to the upper level and bleed the hydraulic system (page 10-4).

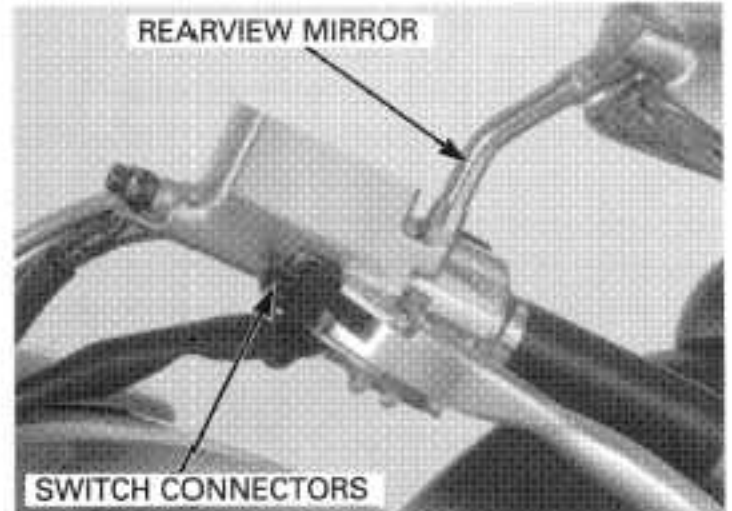

## CLUTCH SLAVE CYLINDER

### REMOVAL

Drain the clutch hydraulic system (page 10-4).

*When removing the oil bolt, cover the end of the hose to prevent contamination.*

Remove the clutch hose oil bolt, sealing washers and clutch hose.



Remove the socket bolts and clutch slave cylinder assembly.

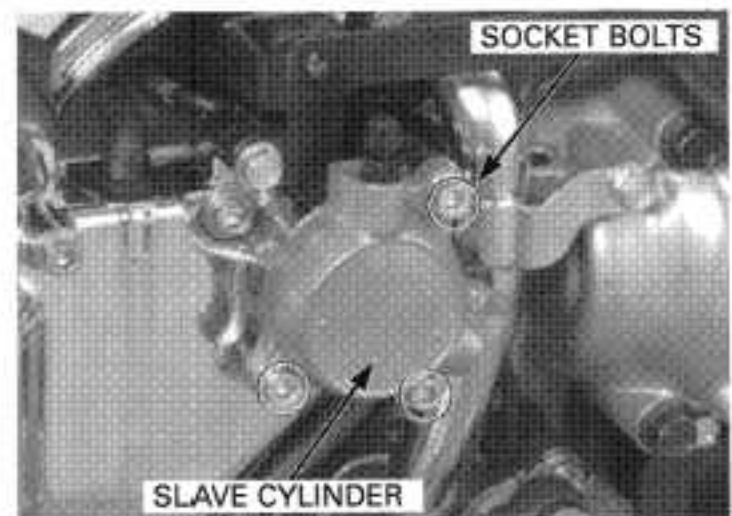

Remove the dowel pins.

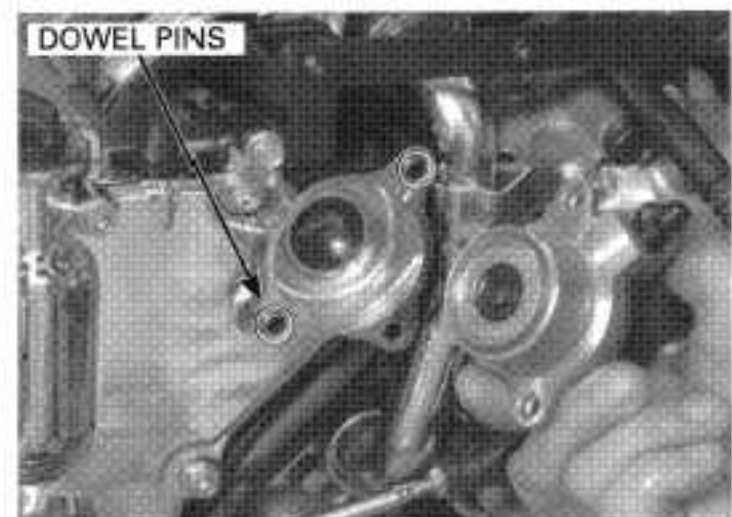

## CLUTCH/GEARSHIFT LINKAGE

### DISASSEMBLY

*Do not use high pressure air or bring the nozzle too close to the inlet.*

Remove the slave cylinder piston and spring.  
If the piston is hard to remove, do the following:  
Place a shop towel over the piston to cushion the piston when it is expelled, and position the cylinder with the piston down.  
Apply small squirts of air pressure into the fluid inlet to remove the pistons.

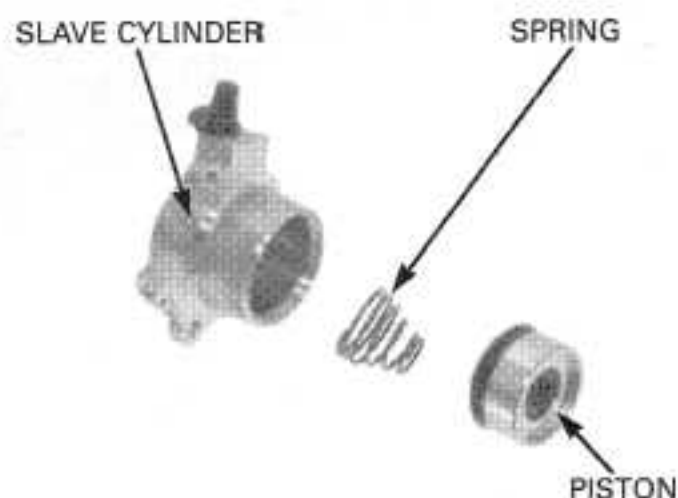

### INSPECTION

Check the piston spring for fatigue or damage.  
Inspect the oil and piston seals for damage or deterioration.  
Replace the oil seal and piston seal if necessary.  
Clean the seal grooves with clean brake fluid.

Check the slave cylinder for scoring or other damage.  
Check the slave cylinder piston for scratches, scoring or other damage.

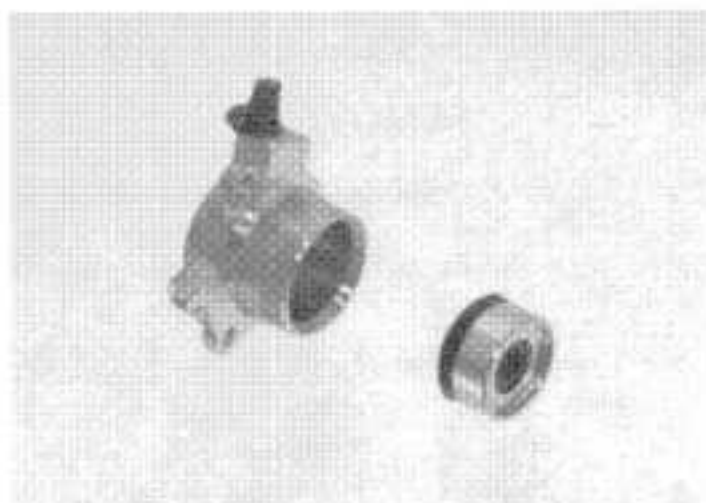

### ASSEMBLY

Install the new piston seal with its groove side facing the slave cylinder.  
Install the new oil seal with its groove side facing the slave cylinder piston.  
Lubricate the piston and piston seal with brake fluid.  
Install the spring and piston into the slave cylinder.

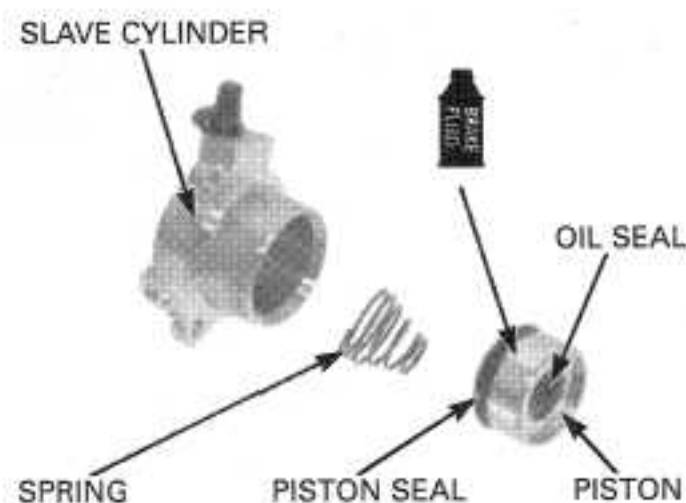

### INSTALLATION

Install the dowel pins.  
Apply silicone grease to the tip of the push rod.  
Install the slave cylinder onto the left crankcase cover.

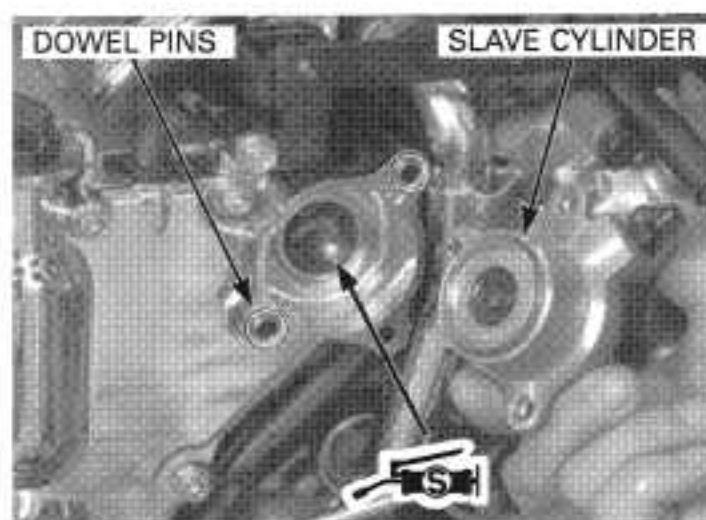



Install and tighten the socket bolts securely.

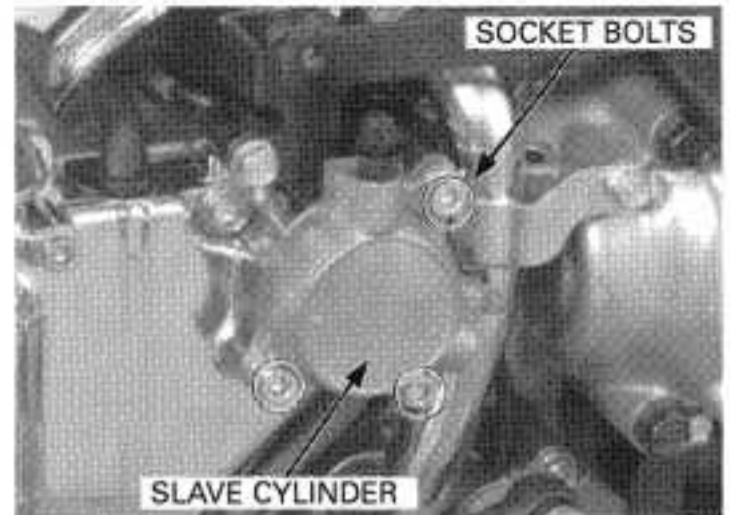

Connect the clutch hose to the master cylinder with the clutch hose oil bolt and new sealing washers. While pushing the clutch hose against the stopper, tighten the clutch hose oil bolt to the specified torque.

**TORQUE: 34 N·m (3.5 kgf·m, 25 lbf·ft)**

Fill the reservoir to the upper level and bleed the hydraulic system (page 10-4).



## RIGHT CRANKCASE COVER

### REMOVAL

Remove the exhaust system (page 2-4).  
Drain the engine oil (page 3-13).

Remove the bolts and clutch cover.  
Remove the bolts and timing cover.

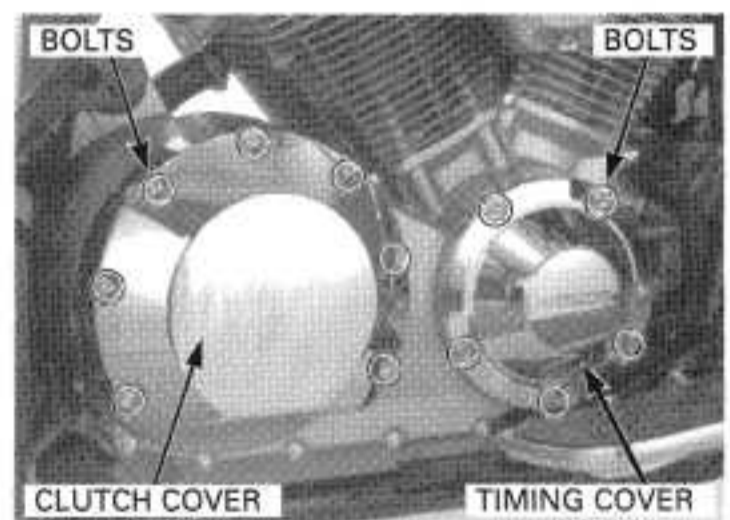

Remove the rubber damper from the clutch cover.

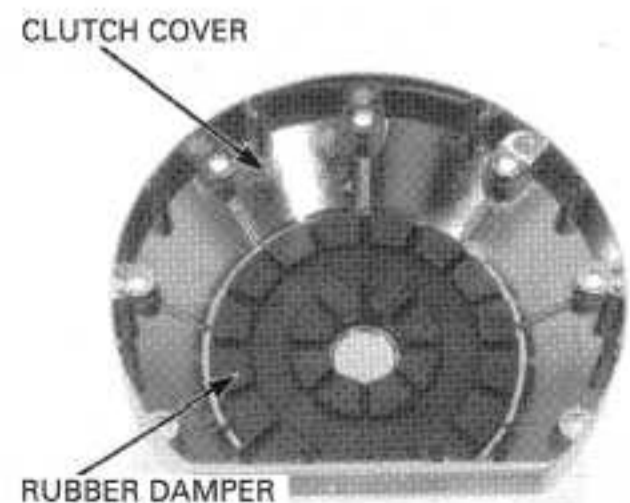



## CLUTCH/GEARSHIFT LINKAGE

Remove the bolts, ground cable and right crankcase cover.

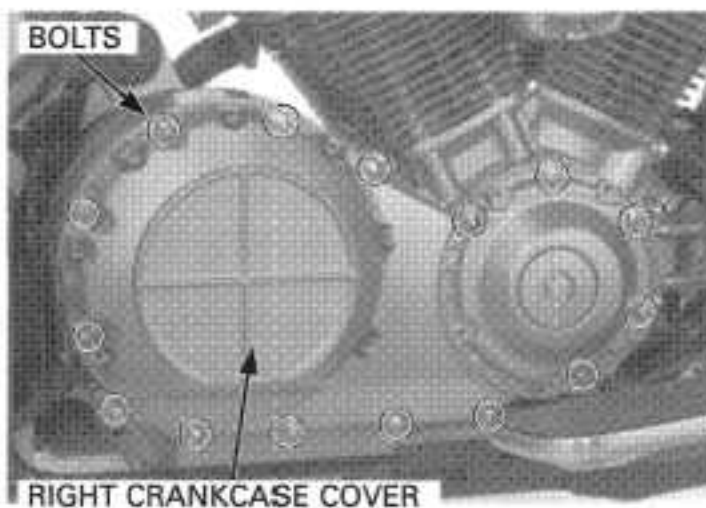

Remove the dowel pins.

### INSTALLATION

*Be careful not to damage the right crankcase and cover mating surfaces.*

Clean the mating surfaces of the right crankcase cover and right crankcase.

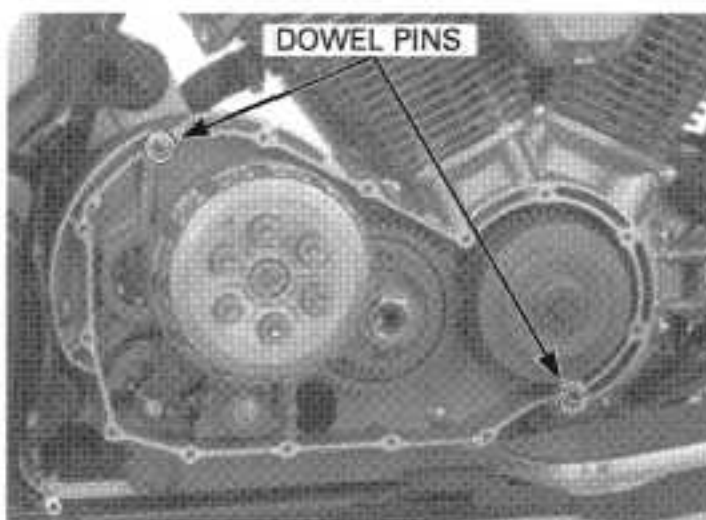

Apply sealant to the right crankcase cover mating surface.  
Install the dowel pins to the right crankcase.

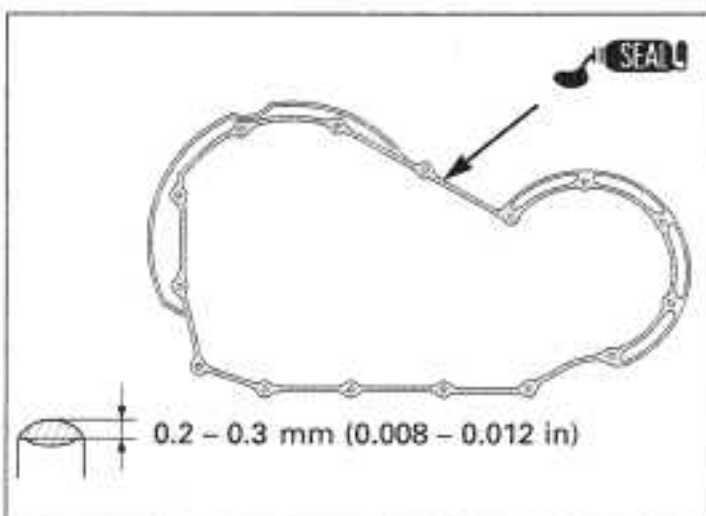

Install the right crankcase cover.  
Install and tighten the bolts securely.

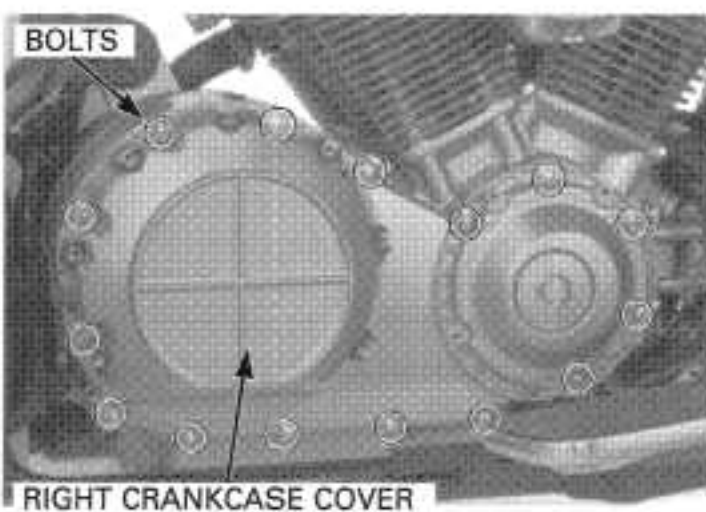

Install the rubber damper to the clutch cover aligning the grooves on the rubber damper with the tabs on the clutch cover.

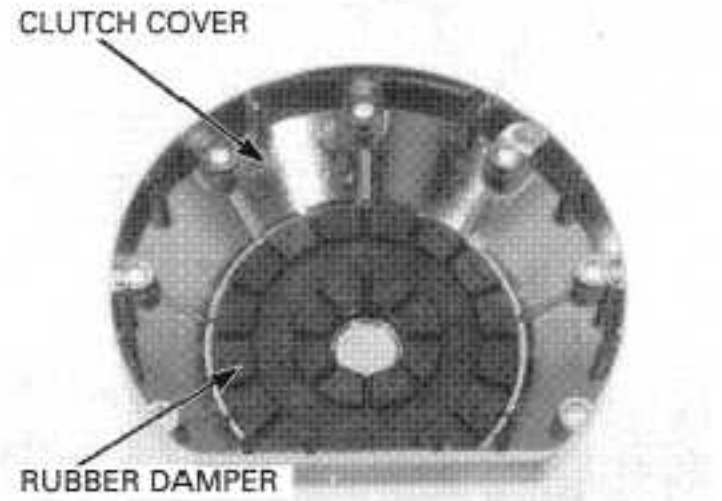

Install the clutch cover bolts and timing cover bolts to their original locations.



Install the clutch cover and timing cover.  
Install and tighten the bolts securely.

Fill the crankcase with the recommended engine oil (page 3-14).  
Install the exhaust system (page 2-5).

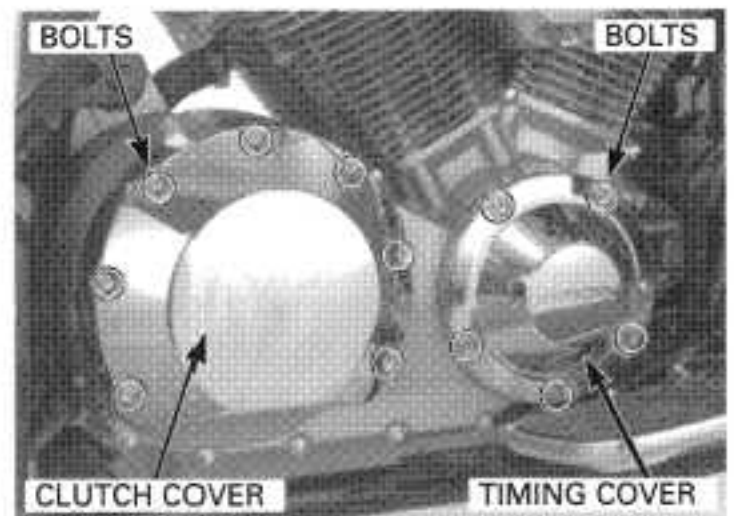

## CLUTCH

### REMOVAL

Remove the right crankcase cover (page 10-13).

Loosen the lifter plate bolts in a crisscross pattern in two or three steps, and remove the bolts and clutch springs.

Remove the lifter plate.

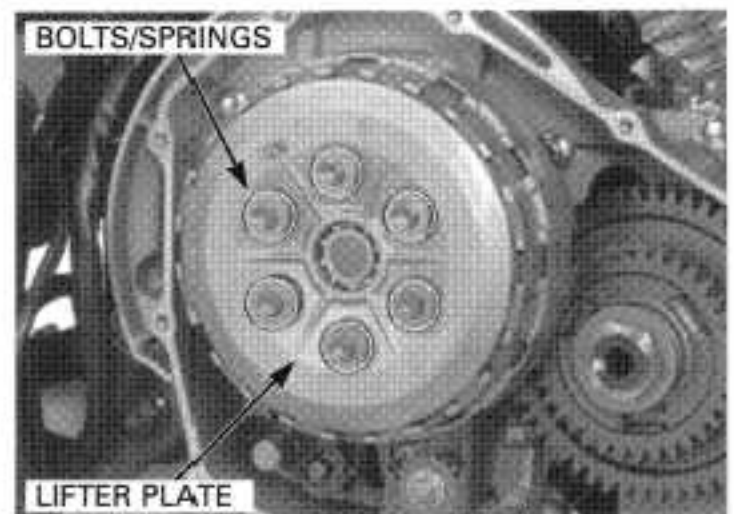

## CLUTCH/GEARSHIFT LINKAGE

Remove the lifter piece and clutch lifter rod.

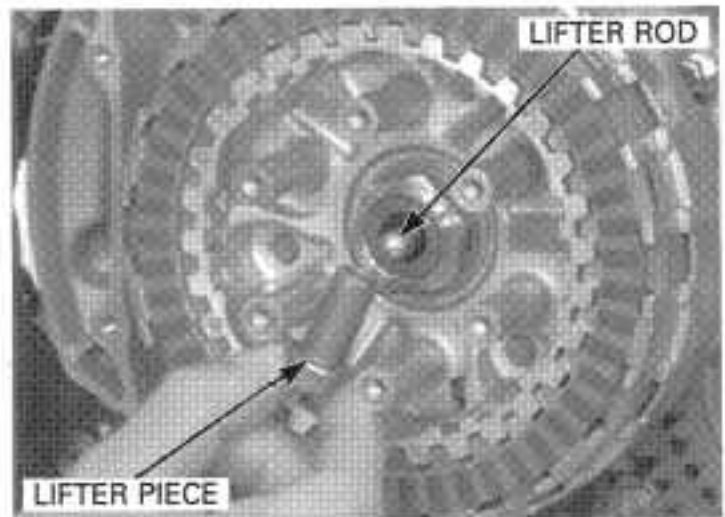

Remove the clutch discs and plates.

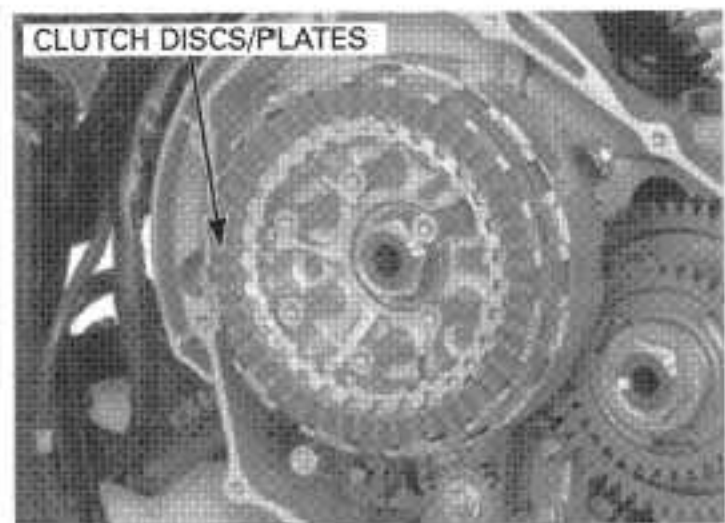

*Be careful not to damage the main-shaft threads.*

Unstake the clutch center lock nut.

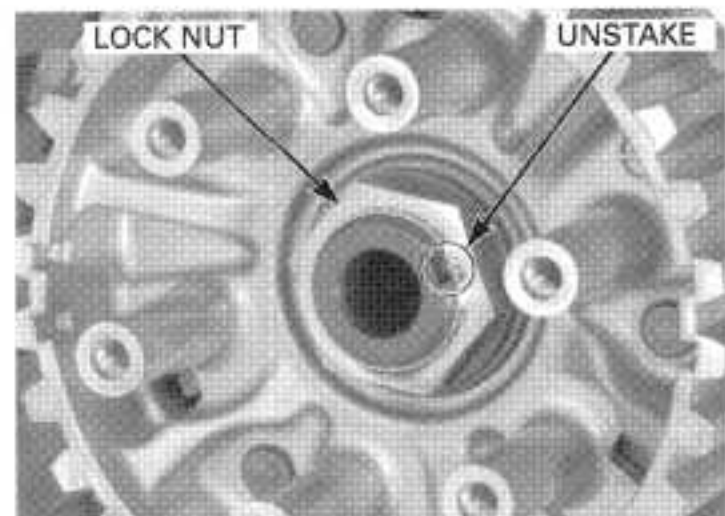

Hold the clutch center with the clutch center holder, then loosen and remove the lock nut.

**TOOL:**

Holder plate

07HGB-001010B or  
07HGB-001010A and  
07HGB-001020B or  
07HGB-001020A

Holder collar "A"

Discard the lock nut.

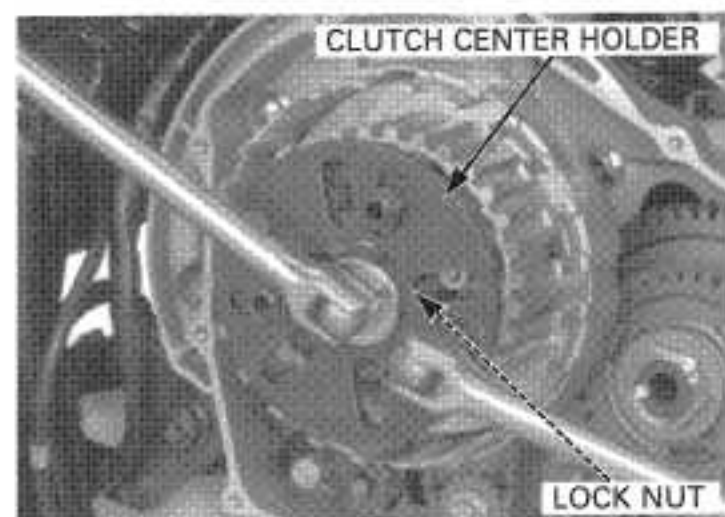

Remove the washer.

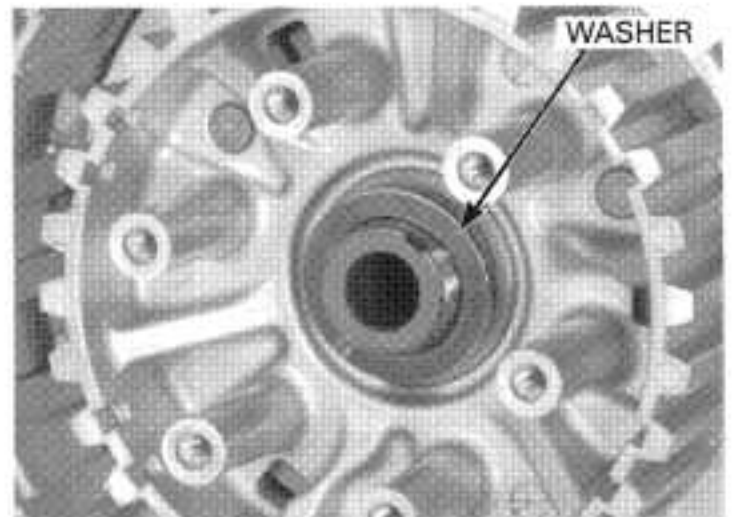

Remove the clutch center.

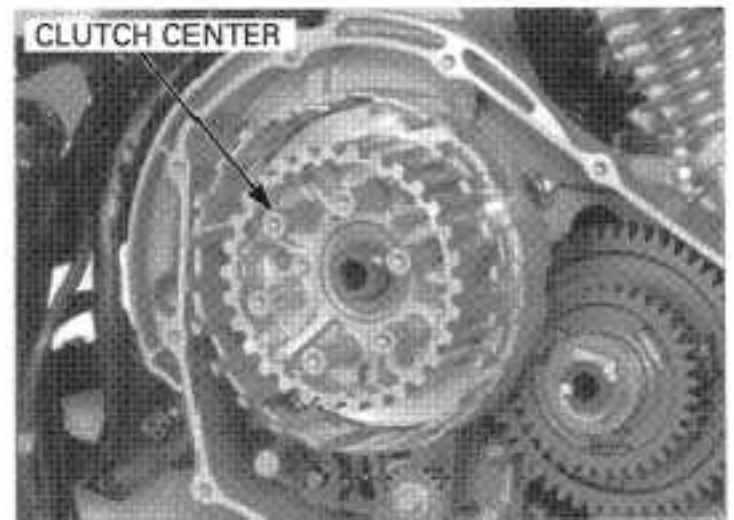

Remove the thrust washer, clutch outer and needle bearing.

Loosen the oil pump driven sprocket bolt.

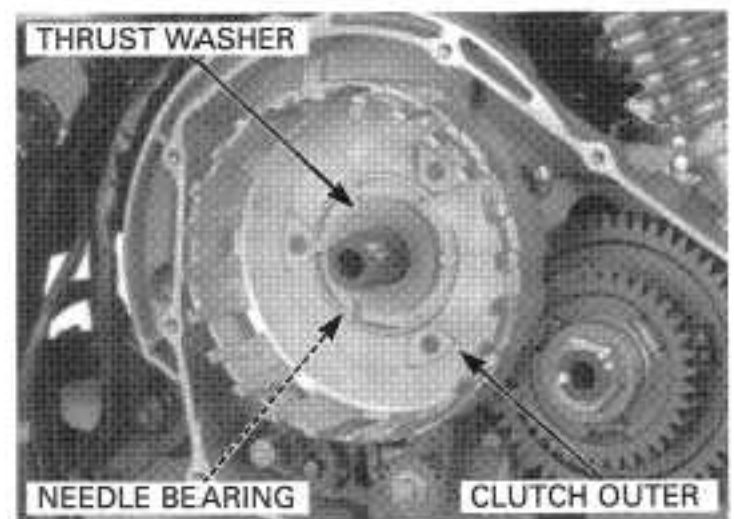

Remove the oil pump driven sprocket bolt/washer.

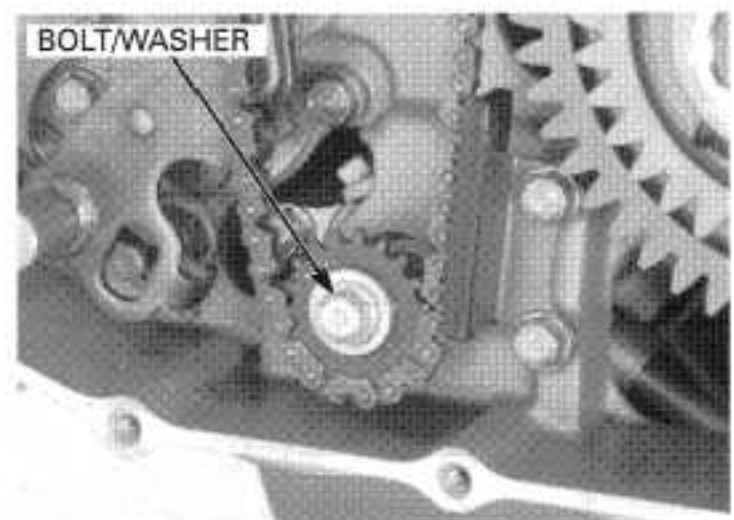

## CLUTCH/GEARSHIFT LINKAGE

Remove the oil pump drive sprocket, driven sprocket and drive chain as an assembly.  
Remove the clutch outer guide.

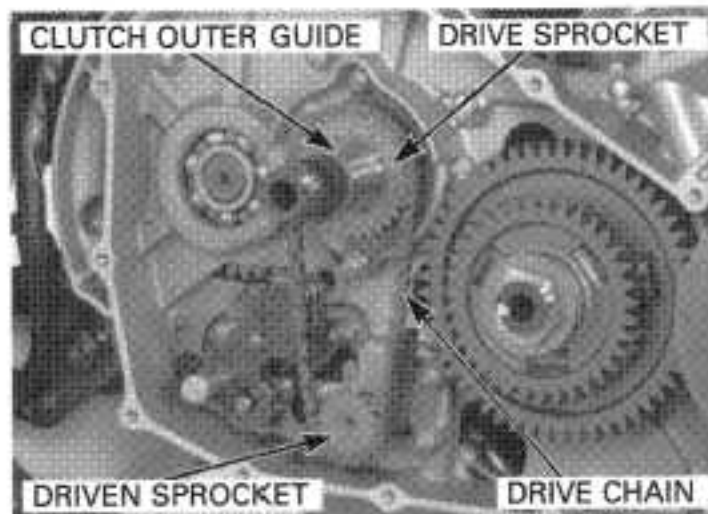

### INSPECTION

#### CLUTCH LIFTER BEARING

Turn the inner race of the lifter bearing with your finger.  
The bearing should turn smoothly and freely without excessive play.  
If necessary replace the bearing.

Remove the bearing from the lifter plate.

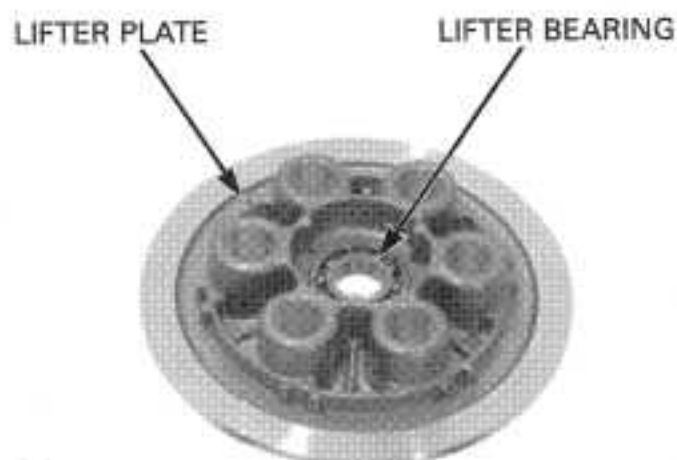

Drive in the bearing to the lifter plate using the special tools.

#### TOOLS:

Driver	07749-0010000
Attachment, 32 x 35 mm	07746-0010100
Pilot, 17 mm	07746-0040400

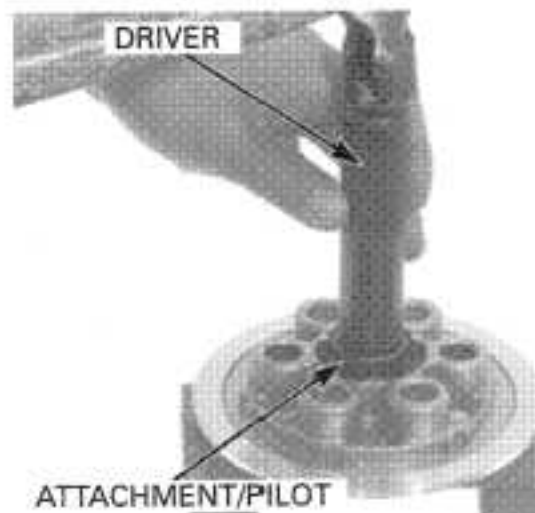

*Replace the  
clutch springs as  
a set.*

#### CLUTCH SPRING

Measure the clutch spring free length.

**SERVICE LIMIT: 56.7 mm (2.23 in)**

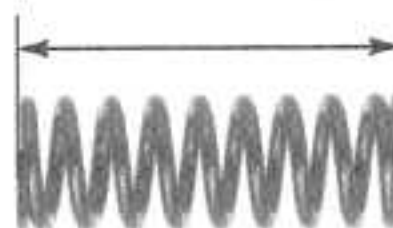



### CLUTCH CENTER

Check the grooves of the clutch center for damage or wear caused by the clutch plates.

Replace if necessary.

CLUTCH CENTER

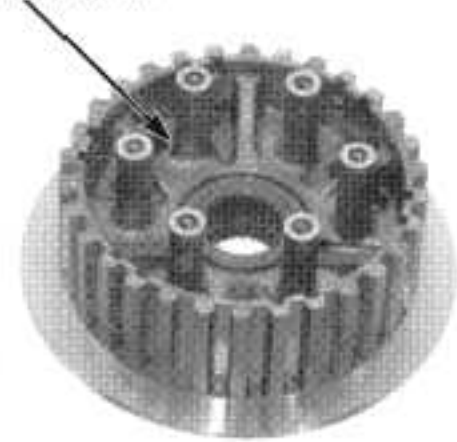

### CLUTCH LIFTER ROD

Check the clutch lifter rod for bends or damage.

LIFTER ROD



*Replace the clutch discs and plates as a set.*

### CLUTCH DISC

Check the clutch discs for signs of scoring or discoloration.

Measure the clutch disc thickness.

**SERVICE LIMIT: 3.1 mm (0.12 in)**

CLUTCH DISC

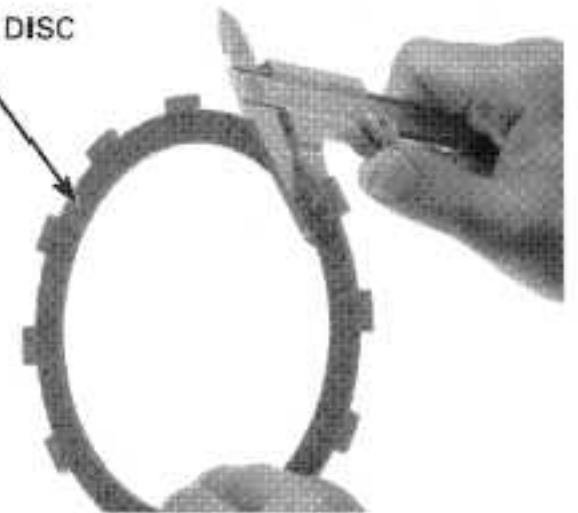

*Replace the clutch discs and plates as a set.*

### CLUTCH PLATE

Check the clutch plate for discoloration.

Check the clutch plate warpage on a surface plate using a feeler gauge.

**SERVICE LIMIT: 0.30 mm (0.012 in)**

CLUTCH PLATE

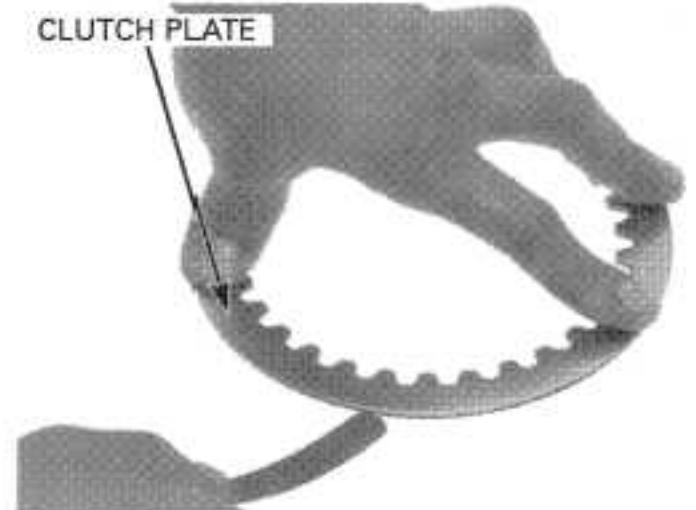

## CLUTCH/GEARSHIFT LINKAGE

### CLUTCH OUTER GUIDE

Measure the clutch outer guide I.D.

**SERVICE LIMIT: 28.8 mm (1.106 in)**

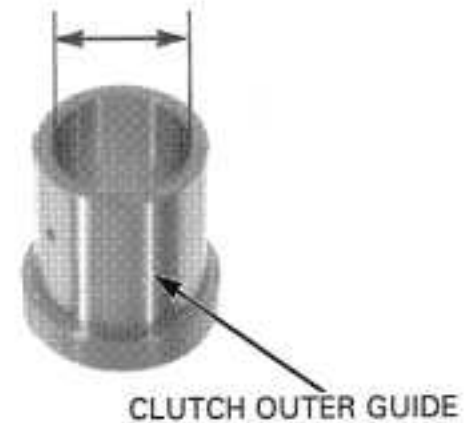

### MAINSHAFT

Measure the mainshaft O.D. at the clutch outer guide.

**SERVICE LIMIT: 27.970 mm (1.1012 in)**

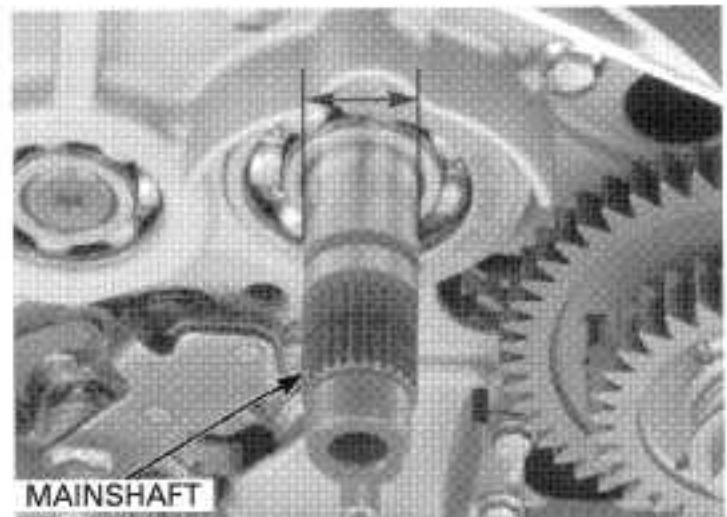

### CLUTCH OUTER

Check the slots in the clutch outer for nicks, indentations or abnormal wear caused by the clutch discs.

Check the clutch outer needle bearing for wear or damage.  
Replace the bearing if necessary.

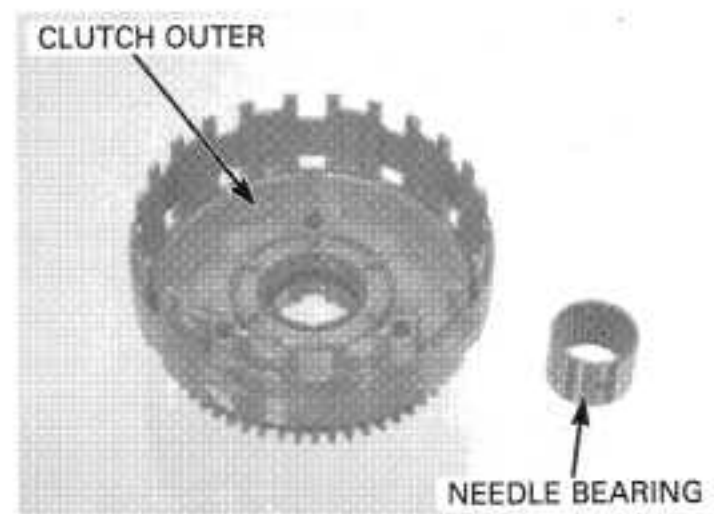

### OIL PUMP DRIVE CHAIN SLIDER

Inspect oil pump drive chain slider for excessive wear or damage.

Remove the bolts and replace if necessary.

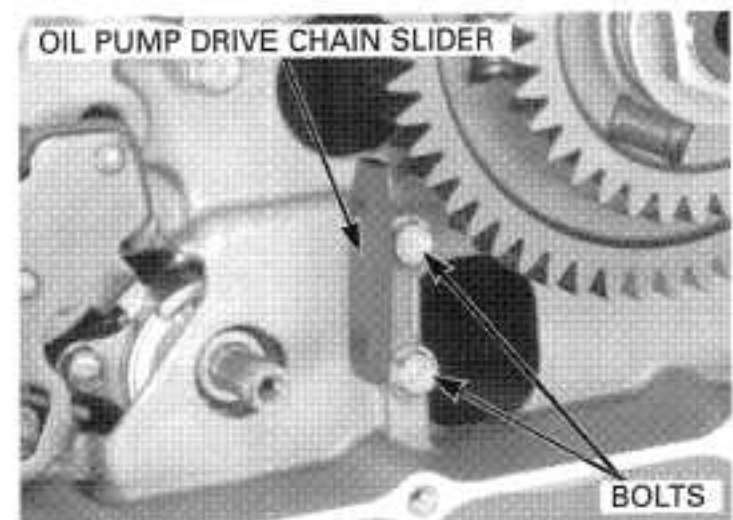

**INSTALLATION**

Coat the clutch outer guide with molybdenum oil solution and install it onto the mainshaft with the flange side facing the crankcase.

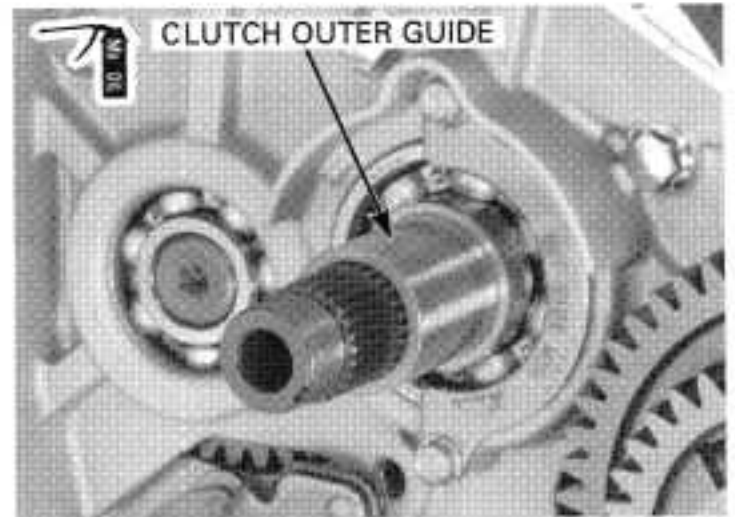

Install the oil pump drive sprocket, driven sprocket and drive chain as an assembly.

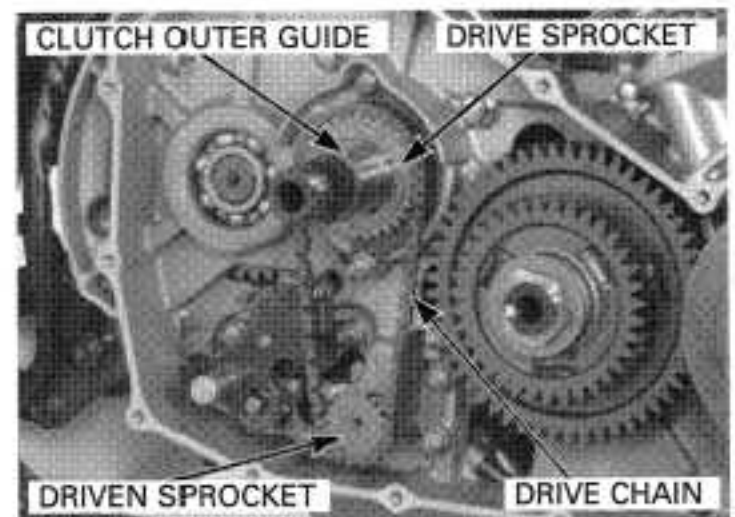

Install the driven sprocket with its "OUT" mark facing out.  
Align the cut-outs on the driven sprocket and the oil pump shaft.

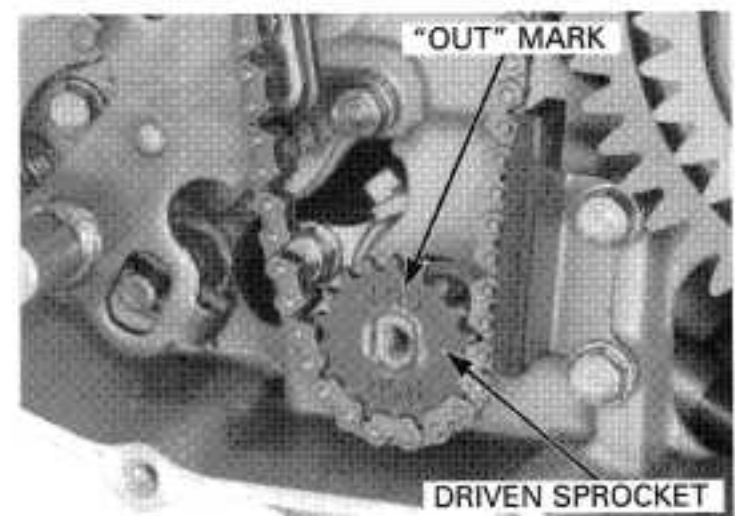

Apply a locking agent to the threads of the oil pump driven sprocket bolt and install the washer and bolt.

Tighten the driven sprocket bolt to the specified torque after installing the clutch outer.

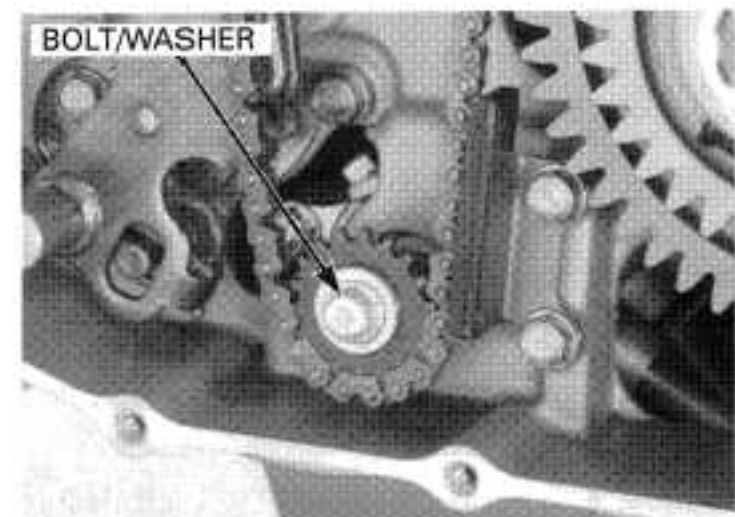

## CLUTCH/GEARSHIFT LINKAGE

Apply molybdenum oil solution to the needle bearing. Install the needle bearing to the mainshaft. Install the clutch outer aligning the holes on the clutch outer with the bosses on the oil pump drive sprocket by turning the oil pump driven sprocket with your finger.

Tighten the oil pump driven sprocket bolt to the specified torque.

**TORQUE: 18 N·m (1.8 kgf·m, 13 lbf·ft)**

Install the thrust washer.

Install the clutch center.

Install the washer with its "OUT" mark facing out.

Apply engine oil to the threads and seating surface of a new clutch center lock nut and install it onto the mainshaft.

Hold the clutch center with the clutch center holder, then tighten the lock nut to the specified torque.

**TOOL:**

Holder plate

07HGB-001010B or

07HGB-001010A and

Holder collar "A"

07HGB-001020B or

07HGB-001020A

**TORQUE: 186 N·m (19.0 kgf·m, 137 lbf·ft)**

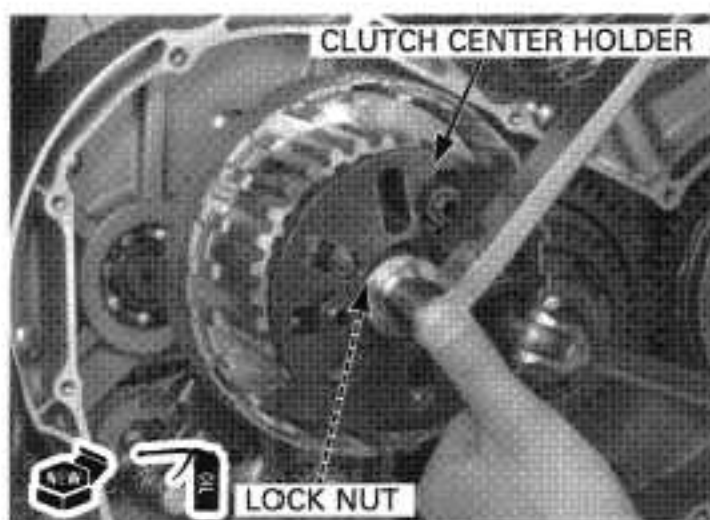
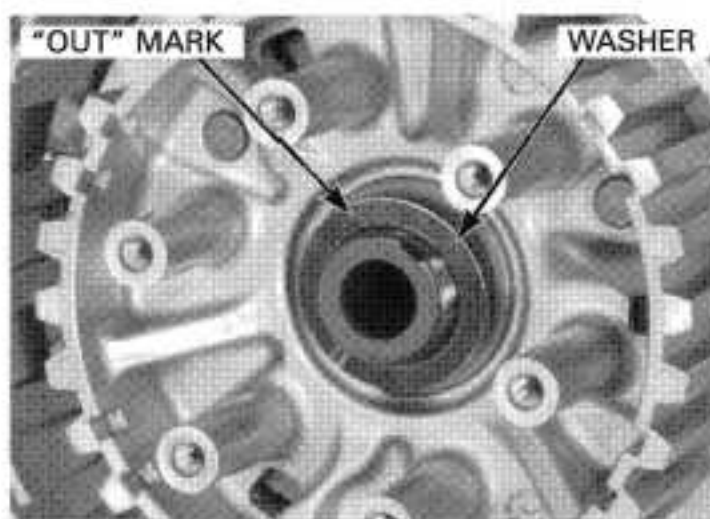
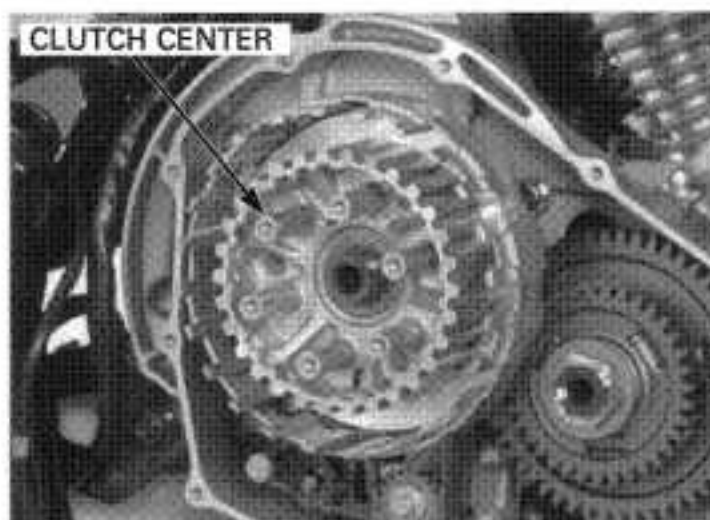
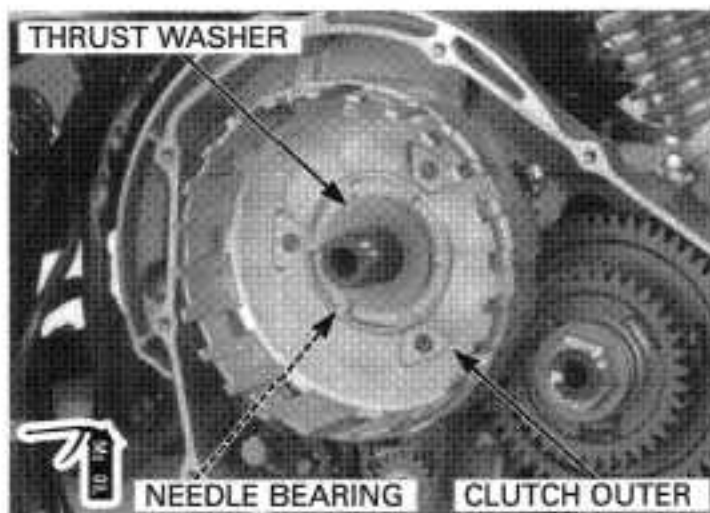



*Be careful not to damage the mainshaft threads.*

Stake the clutch center lock nut into the mainshaft groove.

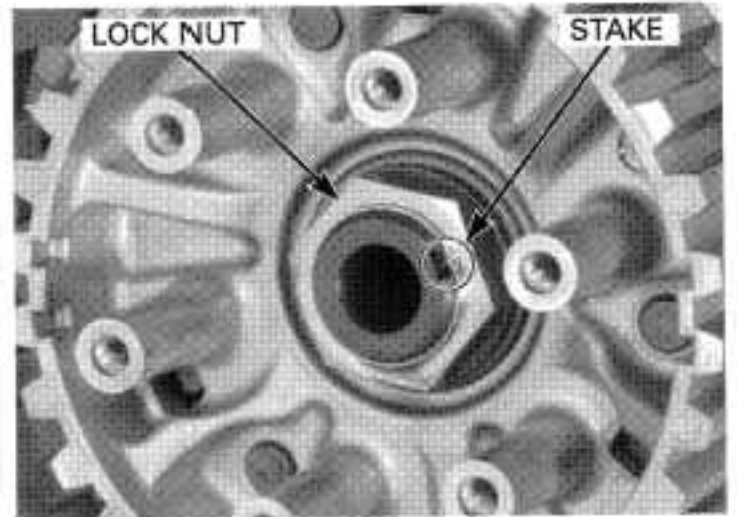

Coat the clutch discs with clean engine oil. Install the eight clutch discs and seven clutch plates alternately, starting with a clutch disc. Install the tabs of the outer clutch disc into the shallow slots of the clutch outer.

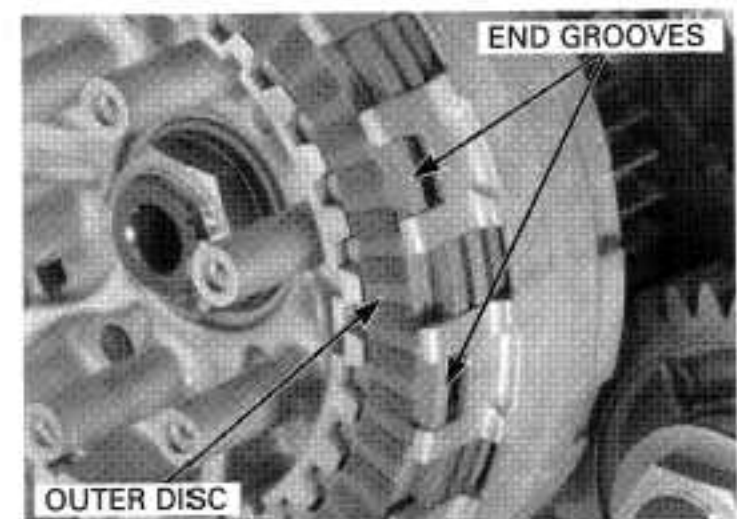
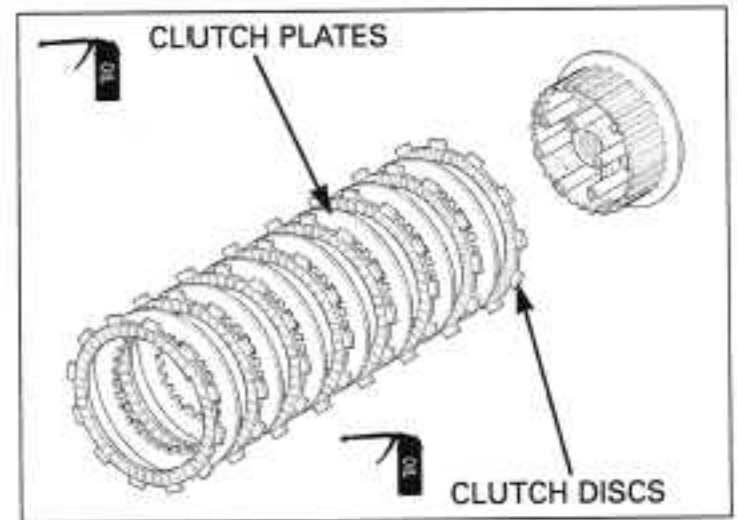

Install the clutch lifter rod into the mainshaft. Coat the clutch lifter piece with molybdenum oil solution and install it into the mainshaft.

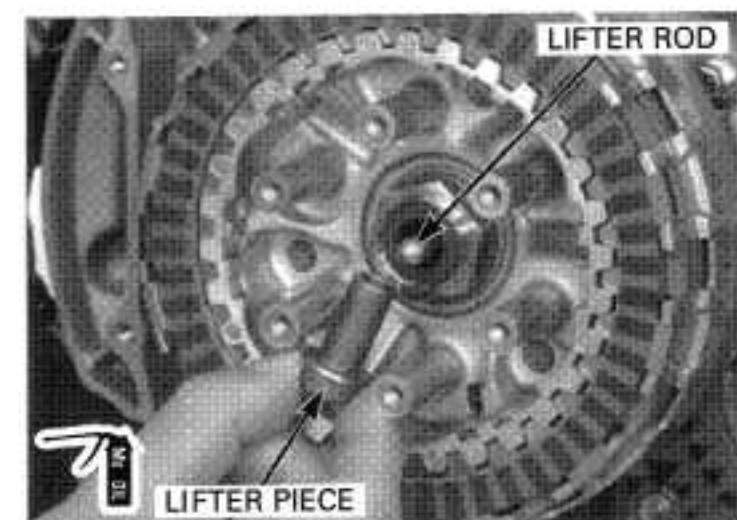



## CLUTCH/GEARSHIFT LINKAGE

Install the clutch lifter plate, clutch springs and clutch pressure plate bolts.  
Tighten the lifter plate bolts in a crisscross pattern in several steps.

**TORQUE: 12 N·m (1.2 kgf·m, 9 lbf·ft)**

Install the right crankcase cover (page 10-14).

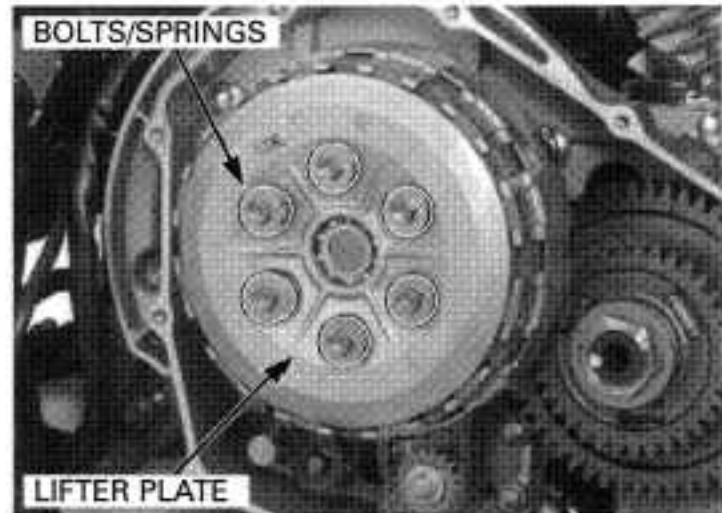

## PRIMARY DRIVE GEAR

### REMOVAL

Wear grooves while working with the primary drive gear. The outer webs of the gear assembly are extremely sharp and should be handled with care.

Remove the right crankcase cover (page 10-13).

Insert the gear holder as shown.

Loosen the primary drive gear bolt and remove the bolt and washer.

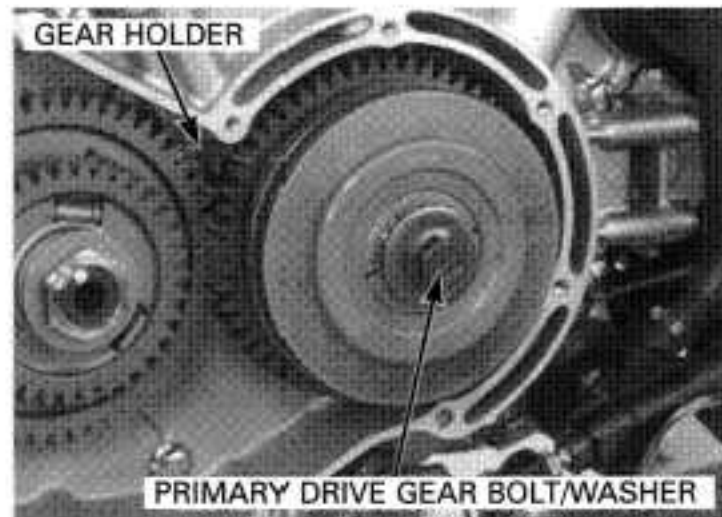

### TOOL:

**Gear holder**

**07724-0010100  
not available in U.S.A.**

Check the primary drive gear for wear or damage.

Replace the primary drive gear if necessary.

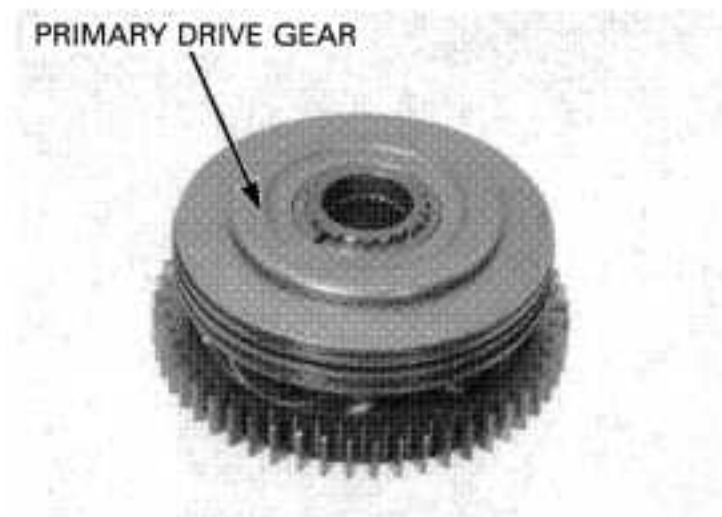

Install the primary drive gear by aligning the wide groove with the wide tooth on the crankshaft.

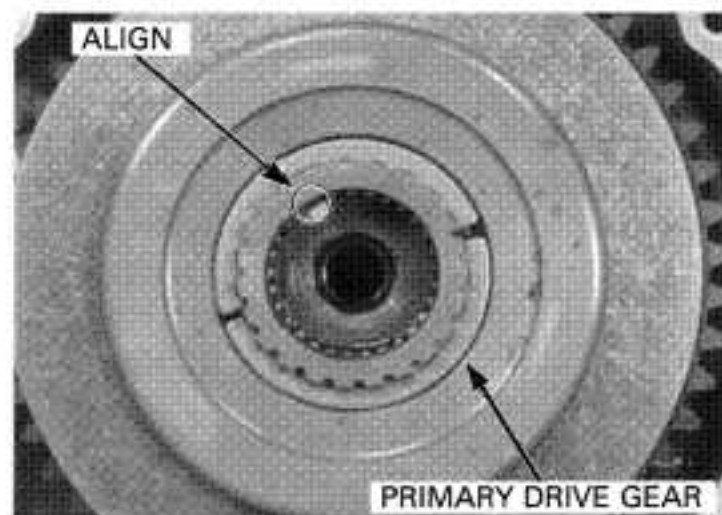

When installing the primary drive gear, align the lines on the primary drive gear and primary driven gear by turning the primary driven gear with your finger.

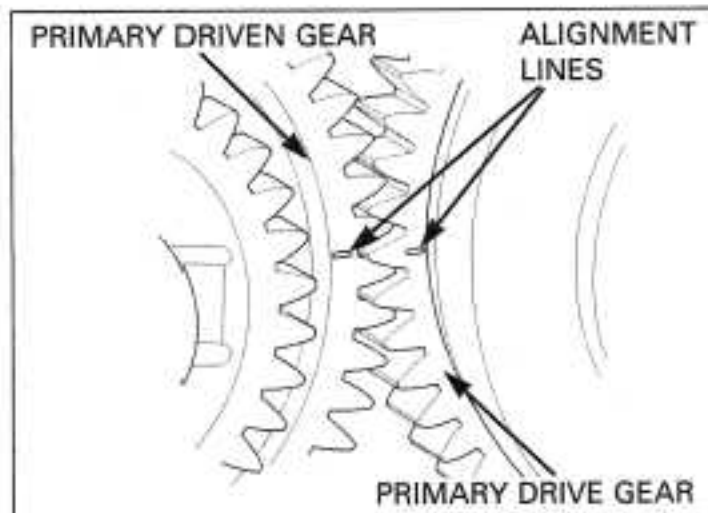

Apply engine oil to the threads of the primary drive gear bolt and install it with the washer.

Insert the gear holder as shown. Tighten the primary drive gear bolt to the specified torque.

**TOOL:**  
Gear holder **07724-0010100**  
not available in U.S.A.

**TORQUE:** 137 N·m (14.0 kgf·m, 101 lbf·ft)

Install the right crankcase cover (page 10-14).

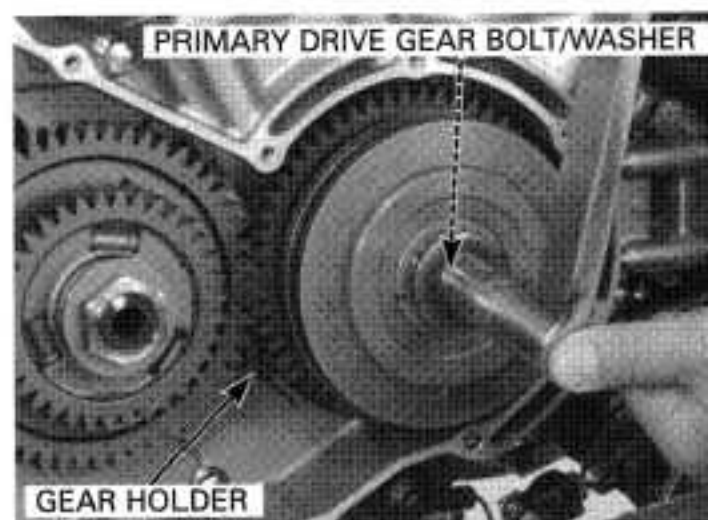

## PRIMARY DRIVEN GEARS

### REMOVAL

Remove the right crankcase cover (page 10-13).  
Remove the clutch (page 10-15).

Unstake the primary driven gear nut.

Insert the gear holder as shown. Loosen the primary driven gear nut and remove the nut.

**TOOL:**  
Gear holder **07724-0010100**  
not available in U.S.A.

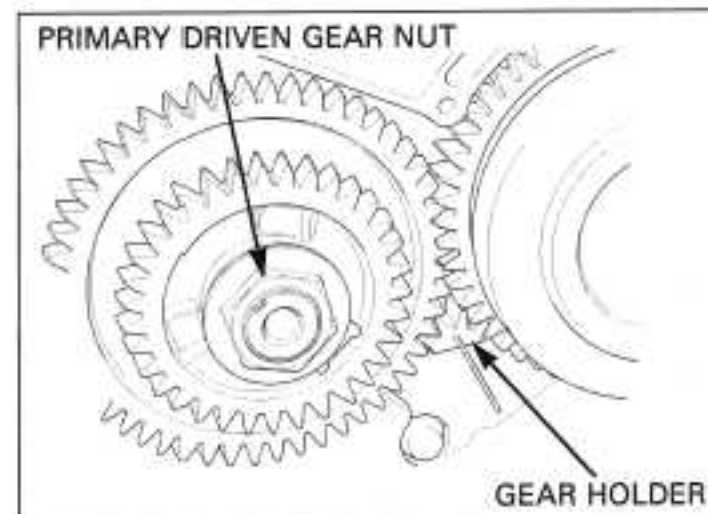
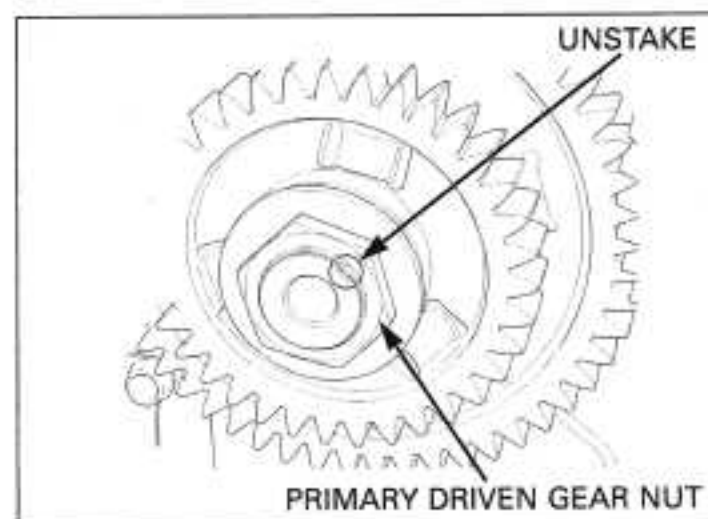

## CLUTCH/GEARSHIFT LINKAGE

Remove the washer and primary driven gear B from the primary shaft.

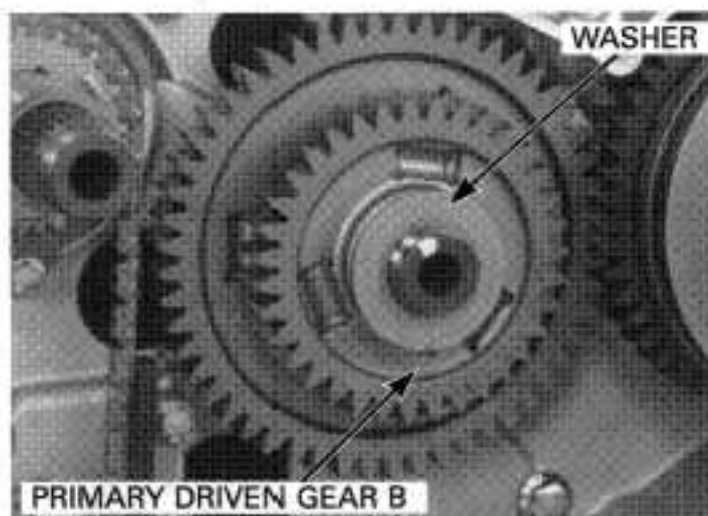

Remove primary driven gear A from the primary shaft.

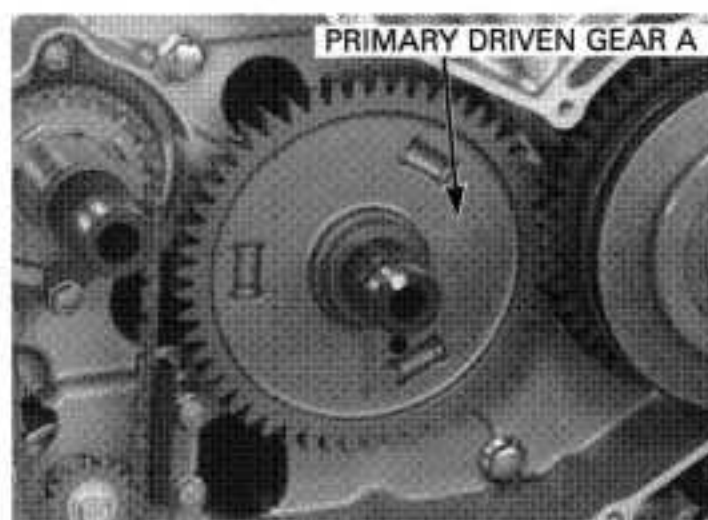

### INSPECTION

#### PRIMARY DRIVEN GEAR B

Check primary driven gear B for wear or damage.

Replace primary driven gear B if necessary.

#### PRIMARY DRIVEN GEAR A

Check primary driven gear A for wear or damage.

Replace primary driven gear A if necessary.

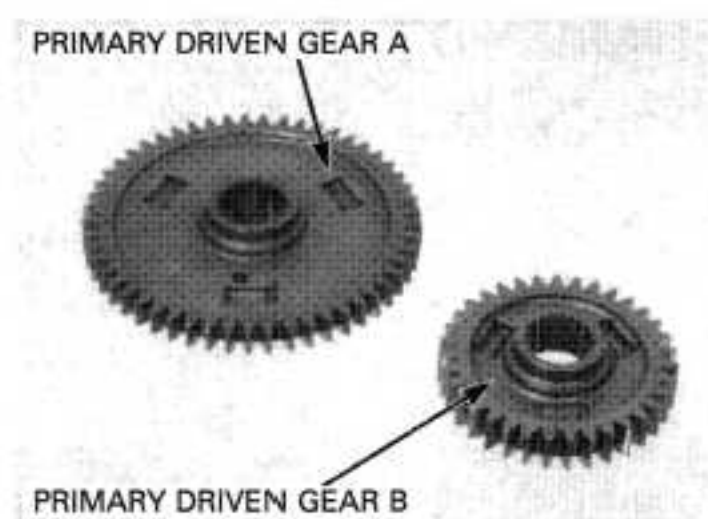

### INSTALLATION

Install primary driven gear A, aligning the wide groove on the primary driven gear with the wide tooth on the primary shaft.

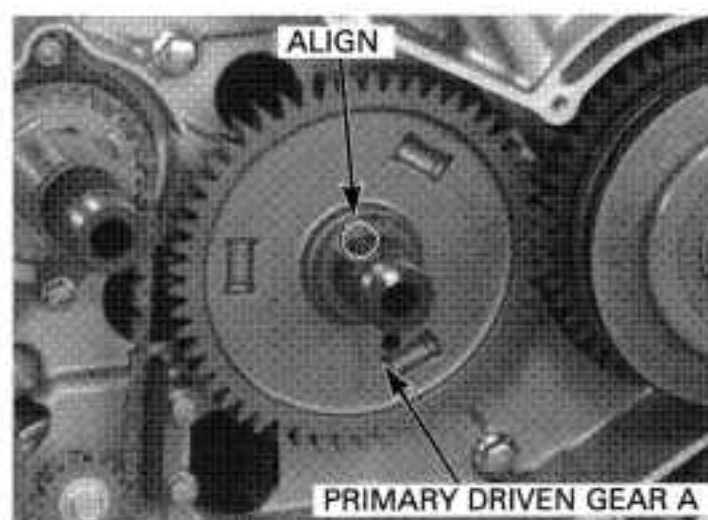

When installing primary driven gear A, align the lines on primary driven gear A and the primary drive gear by turning primary driven gear A with your finger.

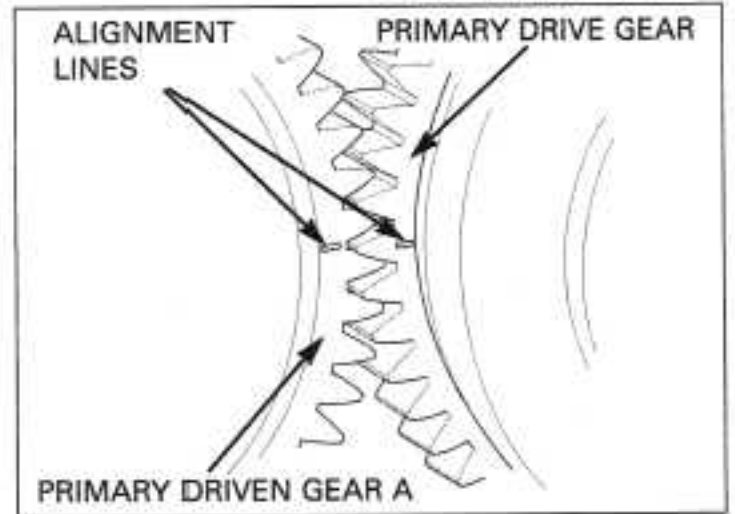

Install primary driven gear B, aligning the wide tooth on primary driven gear B with the wide groove on the primary shaft.

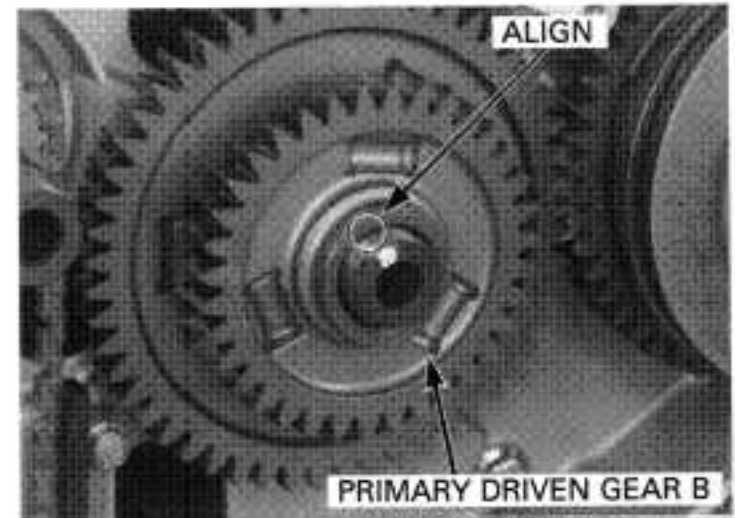

Apply engine oil to the threads of the primary driven gear nut.  
Install new primary driven gear nut with the washer.

Insert the gear holder as shown.

**TOOL:**

**Gear holder**

**07724-0010100**  
**not available in U.S.A.**

Tighten the primary driven gear nut to the specified torque.

**TORQUE: 186 N·m (19.0 kgf·m, 137 lbf·ft)**

Stake the primary driven gear nut into the primary shaft.

Install the clutch (page 10-21).

Install the right crankcase cover (page 10-14).

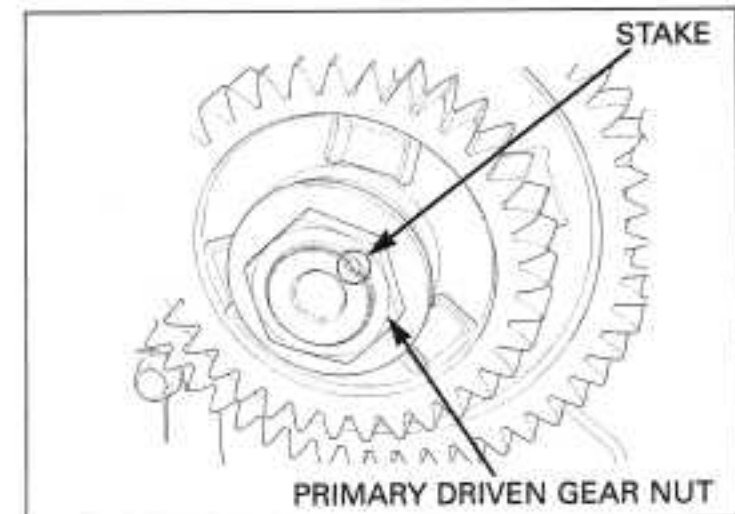
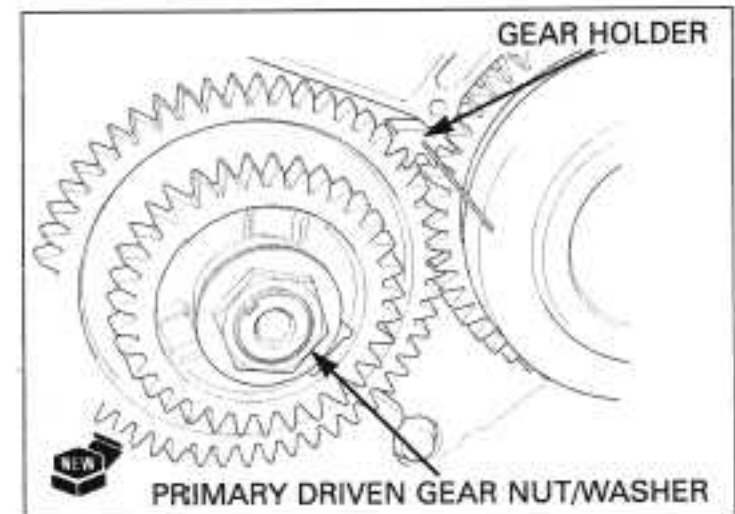



**GEARSHIFT LINKAGE**

**REMOVAL**

Shift the transmission into neutral.

Remove the right crankcase cover (page 10-13).  
Remove the clutch (page 10-15).

Remove the bolt and gearshift arm from the gearshift spindle.

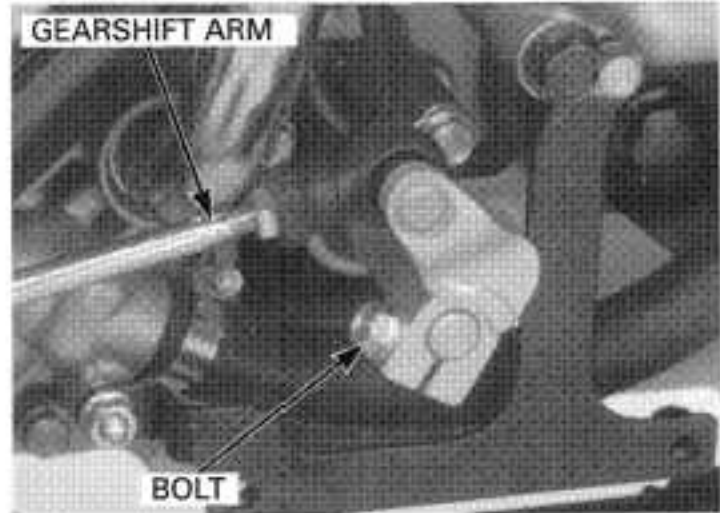

Remove the gearshift spindle and thrust washer.

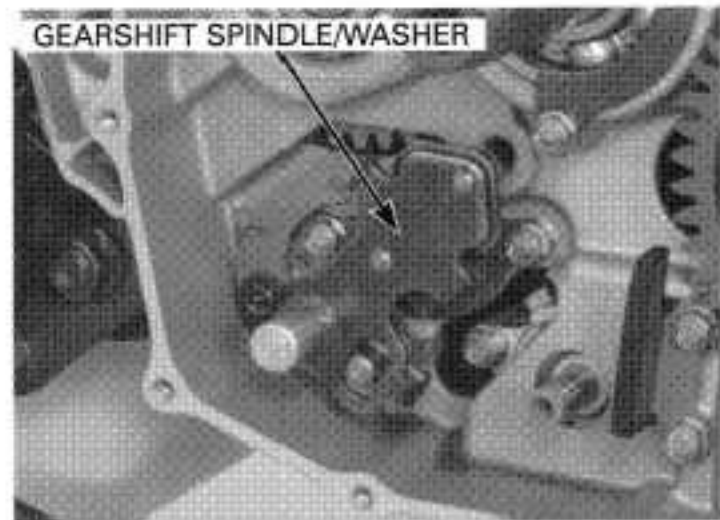

Lift up the stopper arm using a screwdriver to avoid damaging the crankcase and remove the shift drum center socket bolt.

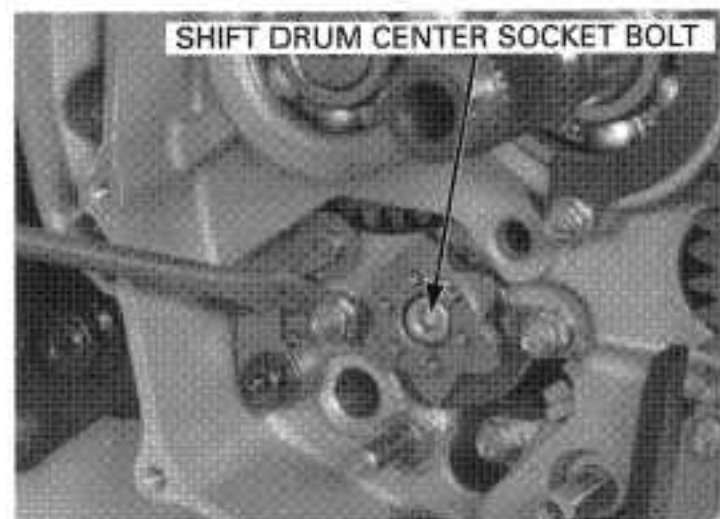

Lift up the stopper arm using a screwdriver to avoid damaging the crankcase and remove the shift drum center.  
Remove the dowel pin.

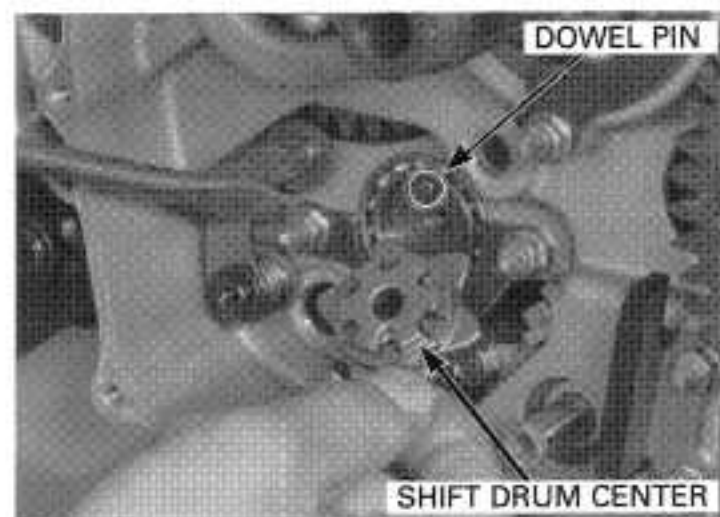



Remove the stopper arm bolt, return spring, washer and arm.

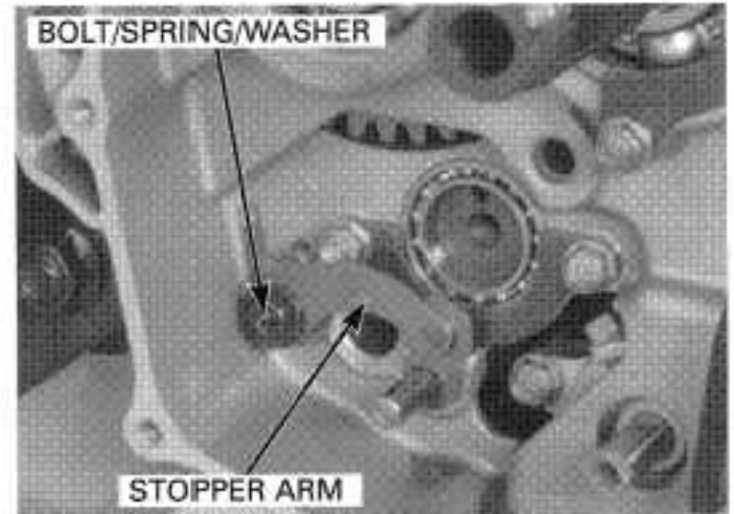

### INSPECTION

Check the gearshift spindle for bends.  
Check the spindle plate for wear or damage.  
Check the return spring for fatigue or damage.

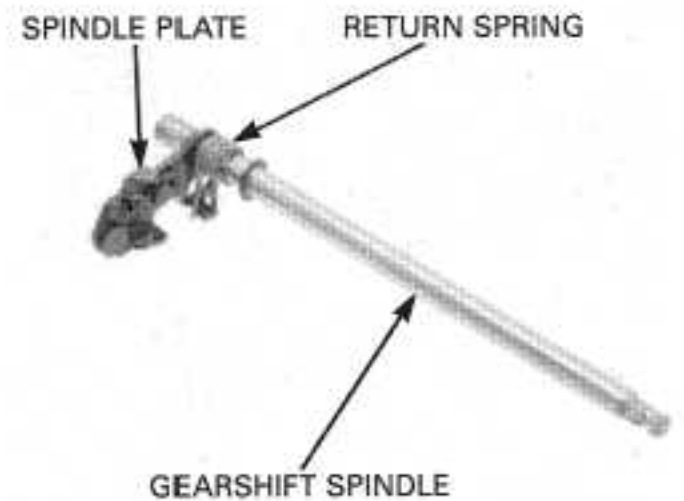

### INSTALLATION

Install the return spring, washer, stopper arm and arm bolt.  
Tighten the stopper arm bolt to the specified torque.

**TORQUE: 12 N·m (1.2 kgf·m, 9 lbf·ft)**

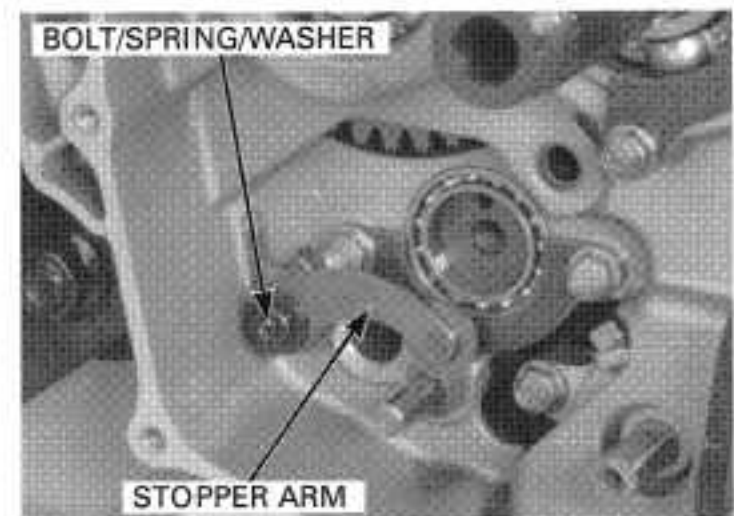

Install the dowel pin.  
Lift up the stopper arm using a screwdriver to avoid damaging the crankcase and install the shift drum center socket by aligning the pin groove in the shift drum center with the dowel pin.

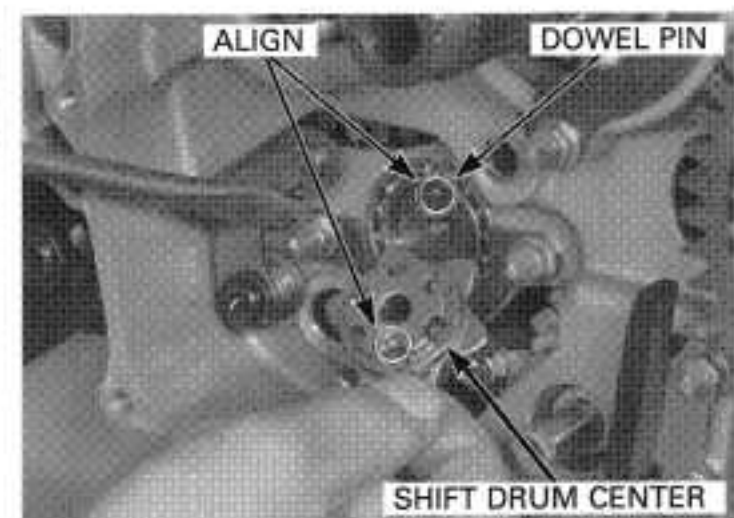

## CLUTCH/GEARSHIFT LINKAGE

Apply locking agent to the shift drum center socket bolt threads.  
Install and tighten the shift drum center socket bolt to the specified torque.

**TORQUE: 23 N·m (2.3 kgf·m, 17 lbf·ft)**



Install the thrust washer onto the gearshift spindle.  
Insert the spindle to the crankcase, aligning the return spring ends with the spring pin.

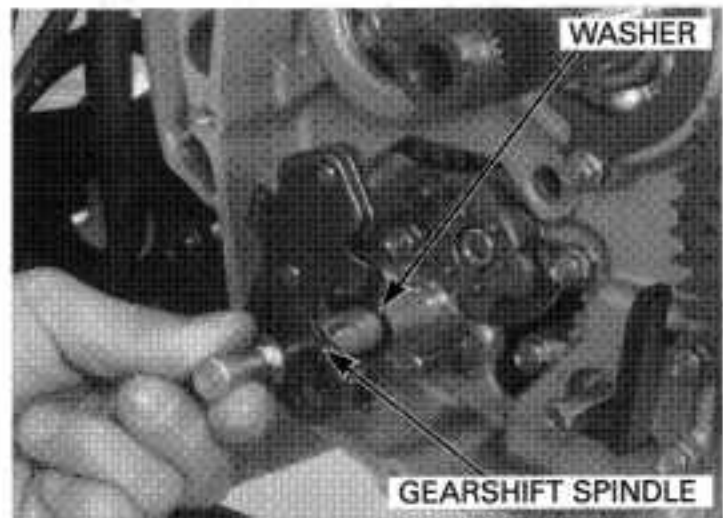

Install the gearshift arm onto the spindle, aligning the slit of the arm with the punch mark on the spindle.

Tighten the change pedal pinch bolt to the specified torque.

**TORQUE: 12 N·m (1.2 kgf·m, 9 lbf·ft)**

Install the clutch (page 10-21).  
Install the right crankcase cover (page 10-14).

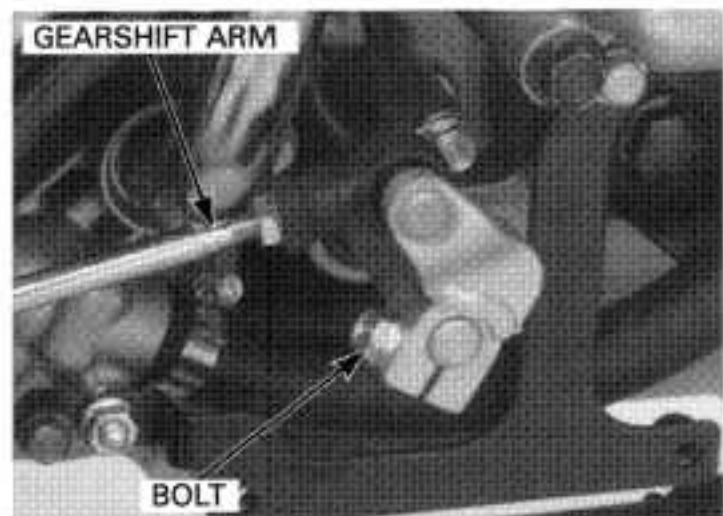

# CRANKSHAFT/TRANSMISSION

26 N·m (2.7 kgf·m, 20 lbf·ft)

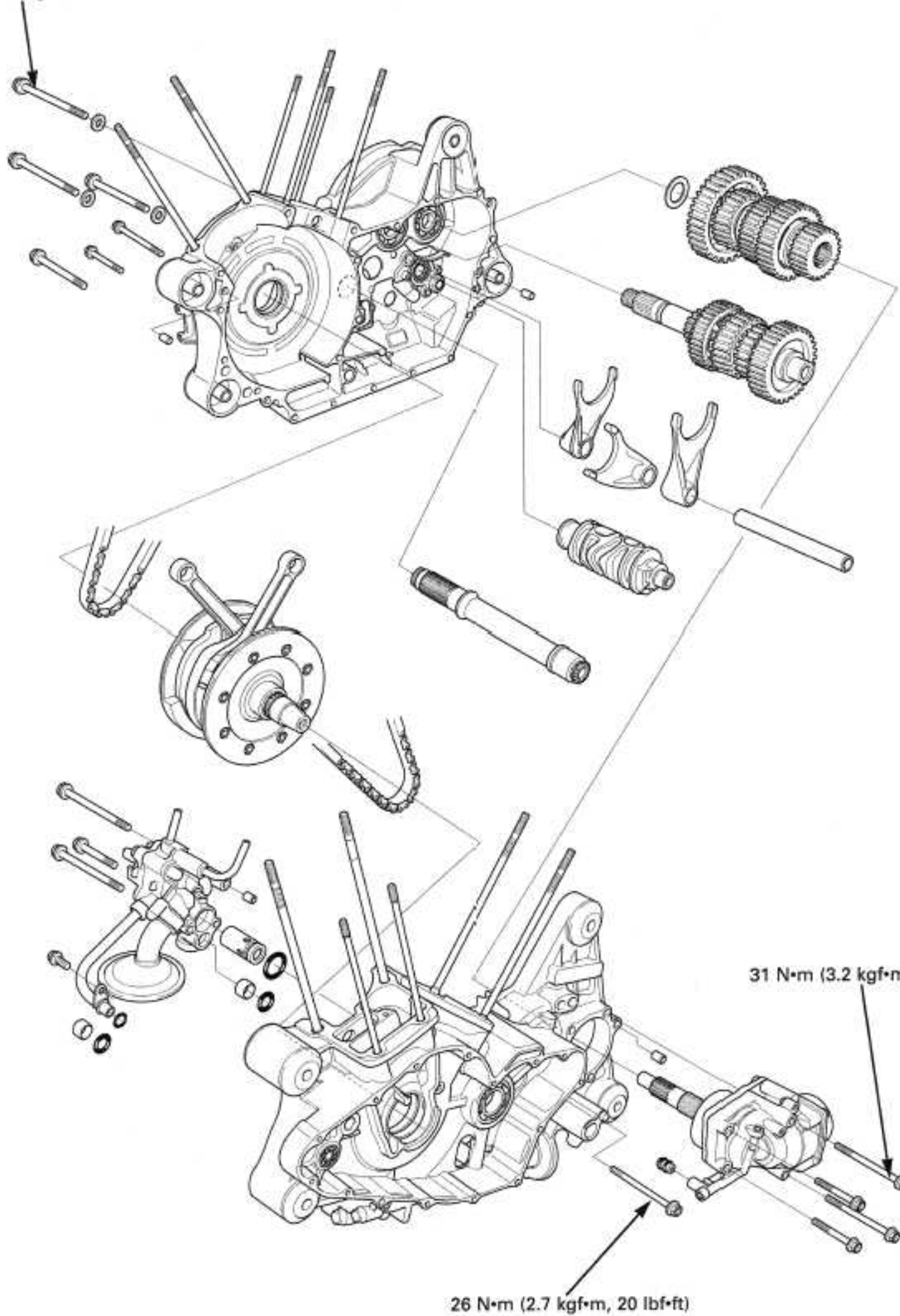

# 11. CRANKSHAFT/TRANSMISSION

<b>SERVICE INFORMATION</b>	<b>11-1</b>	<b>TRANSMISSION</b>	<b>11-11</b>
<b>TROUBLESHOOTING</b>	<b>11-3</b>	<b>CRANKCASE ASSEMBLY</b>	<b>11-17</b>
<b>CRANKCASE SEPARATION</b>	<b>11-4</b>	<b>OUTPUT GEAR</b>	<b>11-19</b>
<b>PRIMARY SHAFT</b>	<b>11-5</b>	<b>CRANKCASE BEARING REPLACEMENT</b>	<b>11-25</b>
<b>CRANKSHAFT/CONNECTING ROD</b>	<b>11-6</b>		

## SERVICE INFORMATION

### GENERAL

- The crankcase halves must be separated to service the connecting rod, crankshaft and transmission (including the shift fork and shift drum). To service these parts, the engine must be removed from the frame (section 7).
- The following parts must be removed before disassembling the crankcase.
  - Cylinder head (section 8)
  - Cylinder and piston (section 9)
  - Clutch, primary drive gear, primary shaft and gearshift linkage (section 10)
  - Water pump (section 6)
  - Starter motor and starter drive gear (section 18)
  - Flywheel and starter clutch (section 18)
- Be careful not to damage the crankcase mating surfaces when servicing.
- Mark and store the connecting rods and bearings to be sure of their correct locations. If the bearings are improperly installed they will block the oil holes, causing insufficient lubrication and eventual engine seizure.
- Be careful not to damage the main journal bearing inserts during crankshaft removal and installation.
- Connecting rod bearing inserts are select fitted and are identified by color code. Select replacement bearings from the code table. Check the oil clearance using a plastigauge after replacing bearing inserts.
- Prior to assembling the crankcase halves, apply sealant to their mating surfaces. Wipe off excess sealant thoroughly.
- Replace the output drive gear and driven gear as a set.
- Whenever you replace the out put driven/drive gears, bearings, bearing holder or gear case, perform the gear contact pattern and backlash inspection and adjust the shim. The extension lines from the gear engagement surfaces should intersect at one point.
- Protect the output gear case with a shop towel or soft jaws while holding it in a vise. Do not clamp it too tightly as it could damage the gear case.



## CRANKSHAFT/TRANSMISSION

### SPECIFICATION

Unit: mm (in)

ITEM		STANDARD	SERVICE LIMIT	
Crankshaft	Connecting rod side clearance	0.10 – 0.25 (0.004 – 0.010)	0.28 (0.011)	
	Crankpin bearing oil clearance	0.032 – 0.062 (0.0015 – 0.0024)	0.070 (0.0028)	
	Main journal bearing oil clearance	0.030 – 0.054 (0.0011 – 0.0021)	0.068 (0.0027)	
	Runout	—	0.05 (0.002)	
Shift fork, fork shaft	I.D.	14.000 – 14.018 (0.5512 – 0.5519)	14.04 (0.553)	
	Claw thickness	5.93 – 6.00 (0.233 – 0.236)	5.83 (0.230)	
	Shift fork shaft O.D.	13.966 – 13.984 (0.5498 – 0.5506)	13.956 (0.5494)	
Transmission	Gear I.D.	M4, M5	31.000 – 31.025 (1.2205 – 1.2215)	31.035 (1.2218)
		C1	30.000 – 30.025 (1.1811 – 1.1821)	30.035 (1.1825)
		C2, C3	33.000 – 33.025 (1.2992 – 1.3002)	33.035 (1.3006)
	Gear bushing O.D.	M4, M5	30.950 – 30.975 (1.2185 – 1.2195)	30.94 (1.218)
		C1	25.987 – 26.000 (1.0232 – 1.0236)	25.977 (1.0227)
		C2/C3	32.950 – 32.965 (1.2972 – 1.2978)	32.94 (1.297)
	Gear-to-bushing clearance	M4, M5	0.025 – 0.075 (0.0010 – 0.0030)	0.095 (0.0037)
		C2, C3	0.035 – 0.075 (0.0014 – 0.0030)	0.095 (0.0037)
	Gear bushing I.D.	M4	27.985 – 28.006 (1.1018 – 1.1025)	28.03 (1.104)
		C1	22.050 – 22.150 (0.8681 – 0.8720)	22.170 (0.8728)
		C2/C3	30.000 – 30.030 (1.1811 – 1.1823)	30.050 (1.1831)
	Mainshaft O.D.	at M4	27.959 – 27.980 (1.1007 – 1.1016)	27.940 (1.1000)
		clutch outer guide	27.980 – 27.993 (1.1016 – 1.1021)	27.970 (1.1012)
	Countershaft O.D.	at C1	21.980 – 21.993 (0.8653 – 0.8659)	21.97 (0.865)
		at C2/C3	29.959 – 29.980 (1.1795 – 1.1803)	29.94 (1.179)
	Bushing-to-shaft clearance	M4	0.005 – 0.047 (0.0002 – 0.0019)	0.067 (0.0026)
		C1	0.057 – 0.170 (0.0022 – 0.0067)	0.190 (0.0075)
		C2/C3	0.020 – 0.071 (0.0008 – 0.0028)	0.091 (0.0036)

### TORQUE VALUES

Right crankcase bolt	26 N•m (2.7 kgf•m, 20 lbf•ft)
Left crankcase bolt	26 N•m (2.7 kgf•m, 20 lbf•ft)
Left crankcase oil orifice bolt	14 N•m (1.4 kgf•m, 10 lbf•ft)
Connecting rod bearing cap bolt	49 N•m (5.0 kgf•m, 36 lbf•ft)
Output gear case mounting bolt	31 N•m (3.2 kgf•m, 23 lbf•ft)
Output drive gear bearing holder bolt	31 N•m (3.2 kgf•m, 23 lbf•ft)
Output drive gear bearing holder socket bolt	31 N•m (3.2 kgf•m, 23 lbf•ft)

Apply oil to the threads and flange surface.



**TOOLS**

Remover weight	07936-371020A or 07936-3710200
Attachment, 32 x 35 mm	07746-0010100
Attachment, 42 x 47 mm	07746-0010300
Attachment, 52 x 55 mm	07746-0010400
Attachment, 62 x 68 mm	07746-0010500
Pilot, 25 mm	07746-0040600
Pilot, 22 mm	07746-0041000
Pilot, 28 mm	07746-0041100
Driver	07749-0010000
Mainshaft holder	07923-6890101
Remover handle	07936-3710100
Bearing remover	07936-3710300
Bearing remover, 22 mm	07936-3710600

**TROUBLESHOOTING****Excessive noise**

- Worn crankshaft main journal bearings
- Worn connecting rod bearings
- Worn connecting rod small end
- Worn, seized or chipped transmission gear
- Worn or damaged transmission bearing

**Hard to shift**

- Bent shift fork
- Bent shift fork shaft
- Damaged shift drum guide groove
- Damaged shift fork guide pin

**Transmission jumps out of gear**

- Worn gear dogs or slots
- Worn shift drum guide groove
- Worn shift fork guide pin
- Worn shift fork groove in gear

**Excessive output gear noise**

- Worn or damaged output drive and driven gears
- Worn or damaged gear case bearings
- Excessive backlash between output drive and driven gears
- Incorrect adjustment shim

**CRANKCASE SEPARATION**

Refer to Service Information (page 11-1) for removal of necessary parts before disassembling the crankcase.

Remove the cam chains from the drive sprockets.

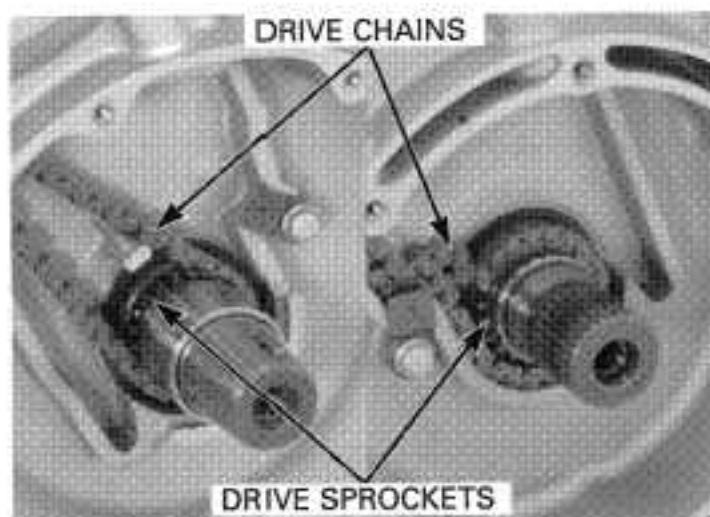

Remove the left crankcase bolt.

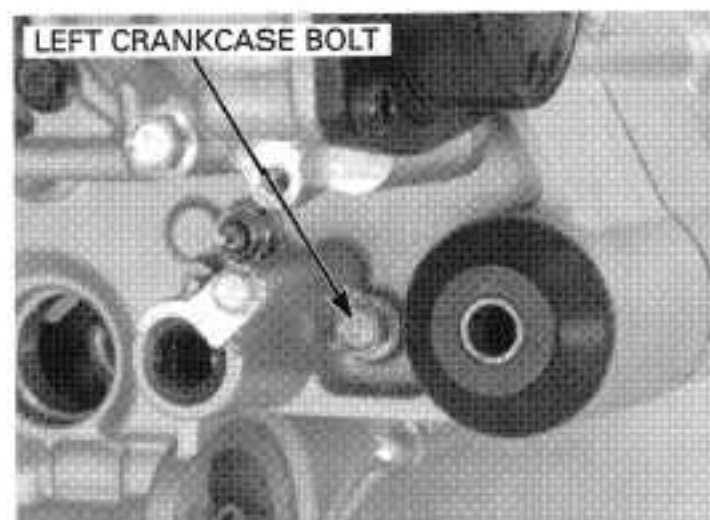

Loosen the right crankcase bolts and remove them with the washer.

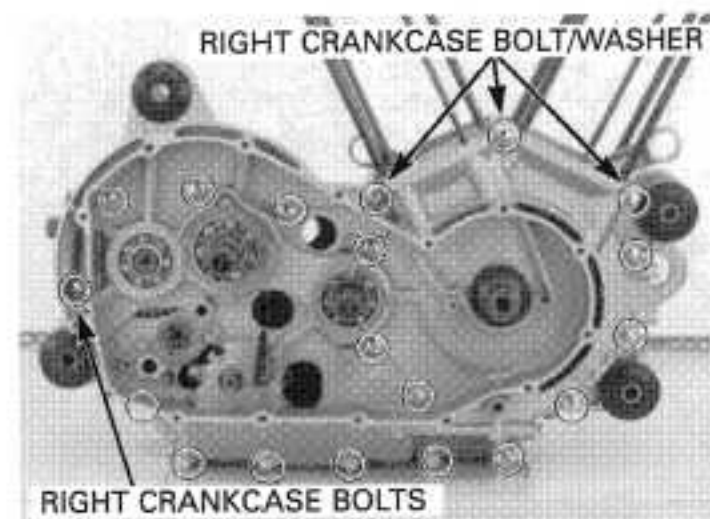

Place the crankcase assembly with the left side down.

*Use the pry slots at the front and rear of the crankcase if necessary.*

Carefully separate the right crankcase from the left crankcase.

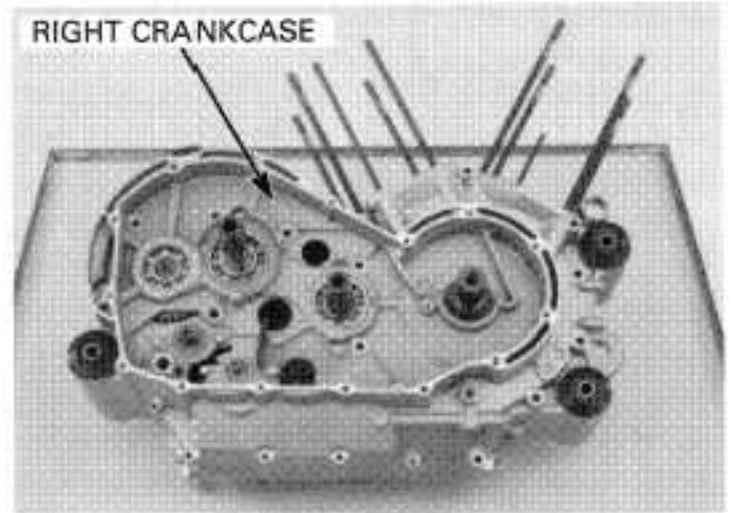

Remove the dowel pins and O-ring.

- Refer to following pages for service of the each part. For the crankcase assembly, see page 11-17.

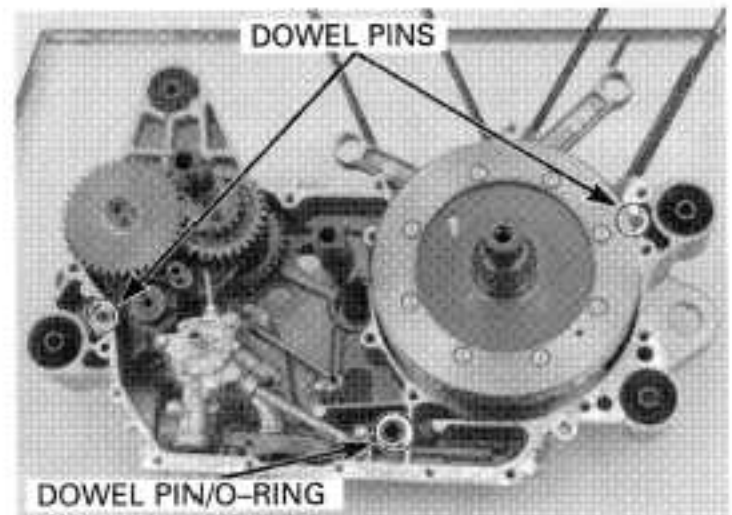

## PRIMARY SHAFT

### REMOVAL/INSTALLATION

Separate the crankcase (page 11-4).

Remove the primary shaft from the left crankcase.

Installation is in the reverse order of removal.

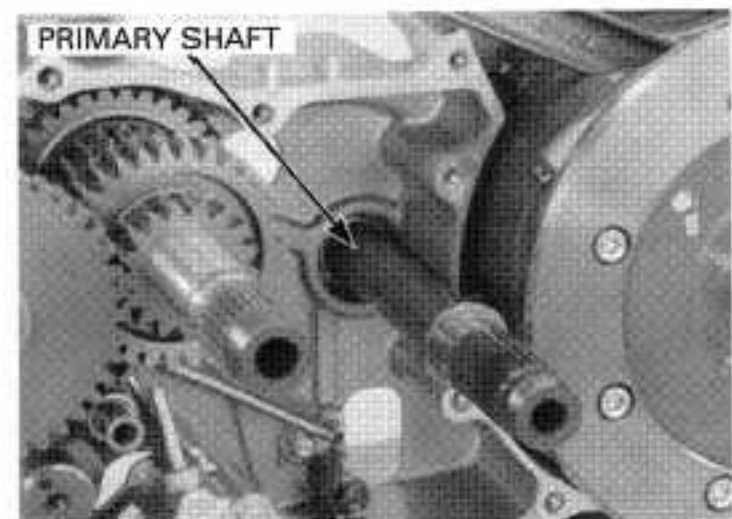

### INSPECTION

Inspect the primary shaft for wear or damage. Replace the primary shaft if necessary.

PRIMARY SHAFT

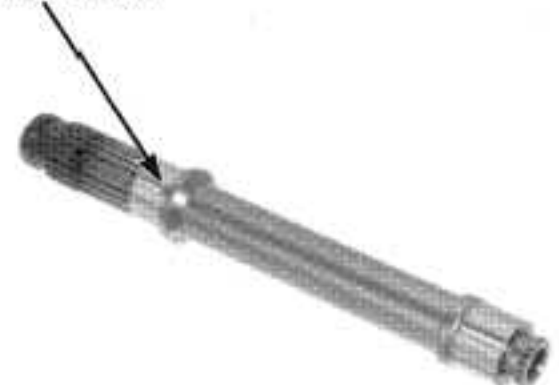

## CRANKSHAFT/TRANSMISSION

Turn the inner race of each bearing with your finger. The bearings should turn smoothly and quietly. Also check that the bearing outer race fits tightly in the crankcase.

Remove and discard the bearings if the races do not turn smoothly, quietly, or if they fit loosely in the crankcase (page 11-25).

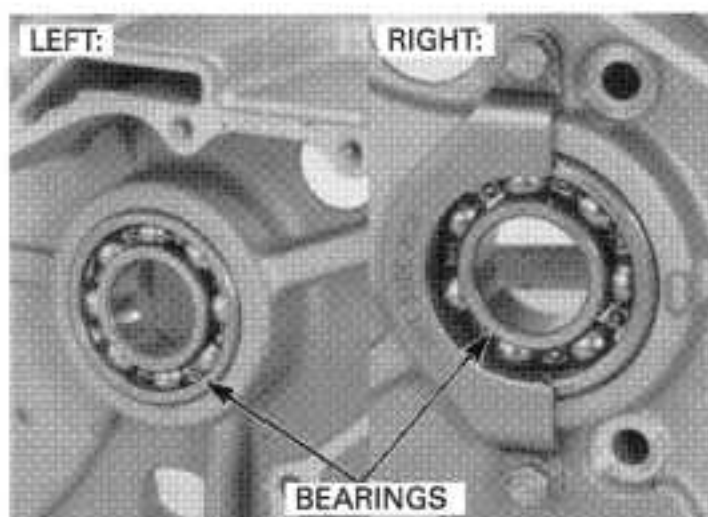

## CRANKSHAFT/CONNECTING ROD

### CRANKSHAFT REMOVAL

Separate the crankshaft (page 11-4).

*During crankshaft and connecting rod service, be careful not to damage the main journal or connecting rod bearing inserts.*

Remove the crankshaft from the left crankcase.

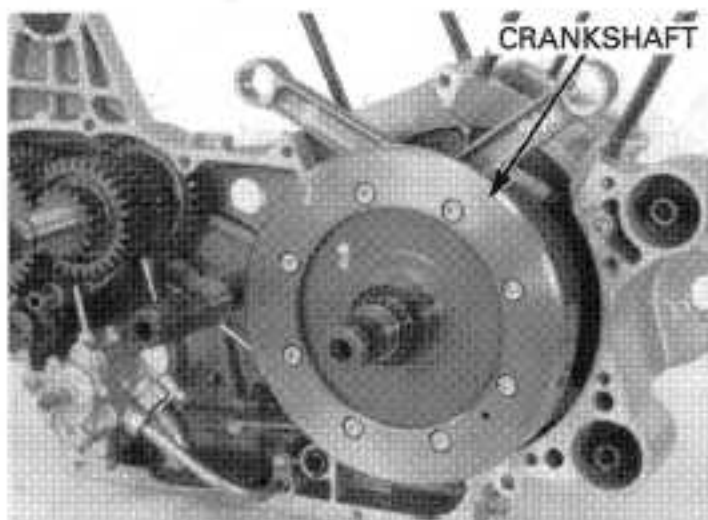

### CONNECTING ROD REMOVAL

Before removing the connecting rods, check the big end side clearance.

Measure the clearance by inserting the feeler gauge between the crankshaft and connecting rod big end.

**SERVICE LIMIT: 0.28 mm (0.011 in)**

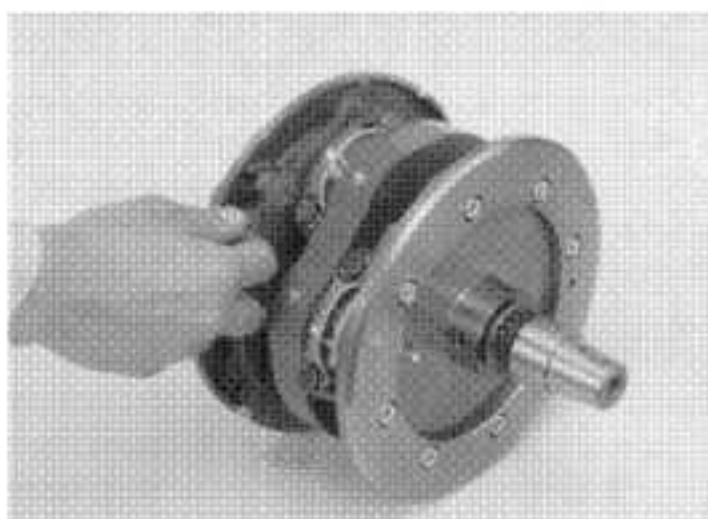

*Tap the side of the cap lightly if the bearing cap is hard to remove.*

Remove the connecting bearing cap bolts and the bearing caps.

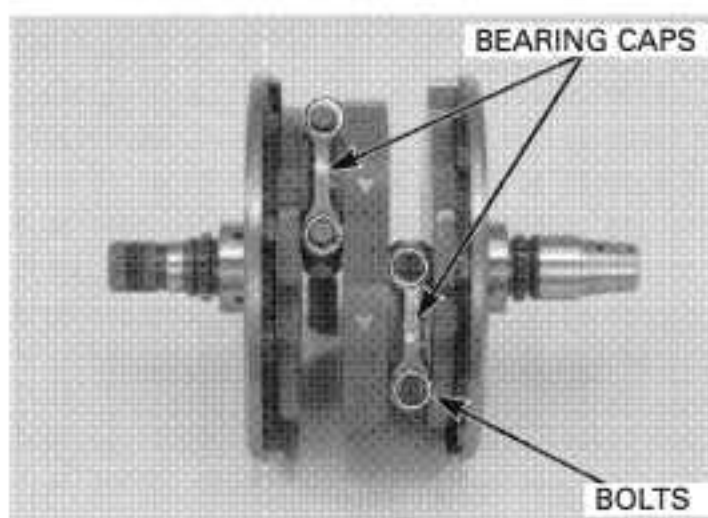

Mark the rods, bearings and caps as you remove them to indicate the correct cylinder and position on the crankpins for reassembly.

For the connecting rod small end inspection, see page 9-7.

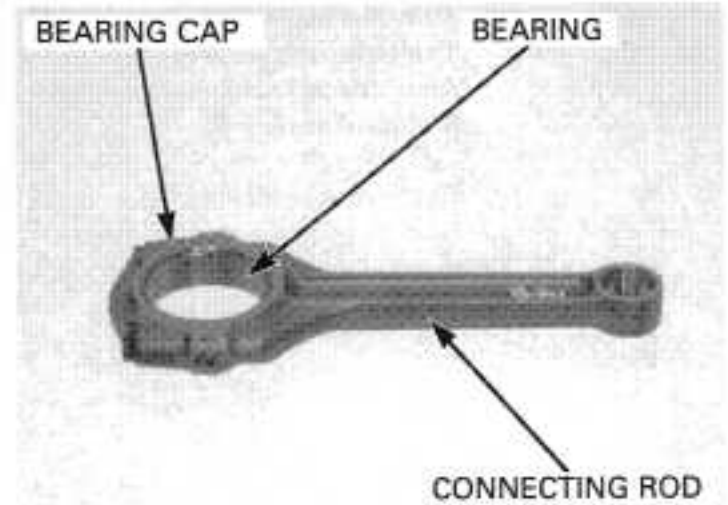

### CRANKSHAFT INSPECTION

#### CRANKSHAFT RUNOUT

Place the crankshaft on a stand or V-blocks.  
Set a dial indicator on the main journals.  
Rotate the crankshaft two revolutions and read the runout.

**SERVICE LIMIT: 0.05 mm (0.002 in)**

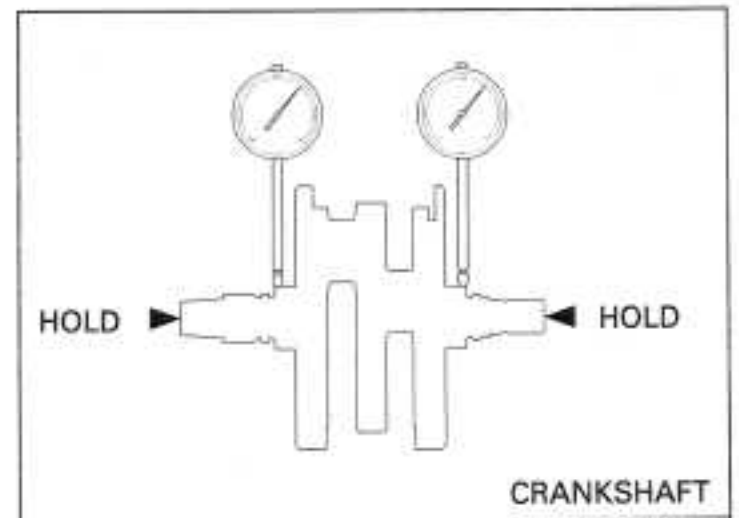

### CONNECTING ROD BEARING INSPECTION

Inspect the bearing inserts for unusual wear, damage or peeling and replace as necessary.

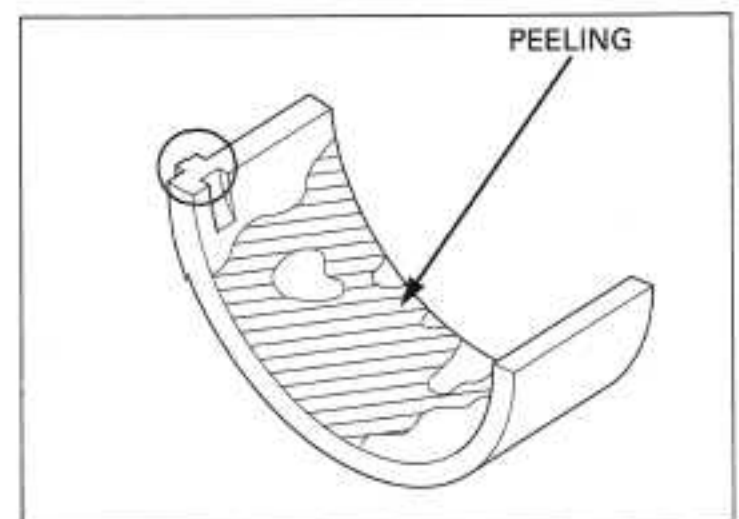

### OIL CLEARANCE INSPECTION

Clean any oil from the bearing inserts and crankpins.

Put a strip of plastigauge lengthwise on each crankpin avoiding the oil hole.

Carefully install the connecting rods and bearing caps on the correct crankpins.

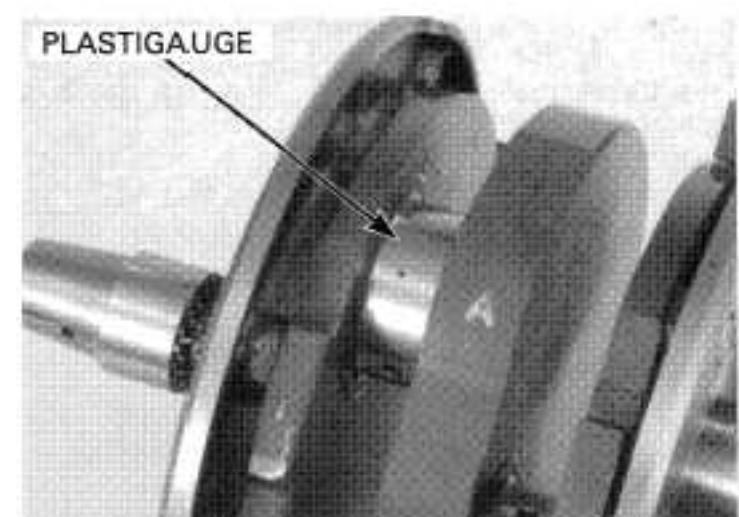



## CRANKSHAFT/TRANSMISSION

*Do not rotate the crankshaft during inspection.*

Apply engine oil to the threads and seating surfaces of the bearing cap bolts. Install the bolts and tighten them evenly.

**TORQUE: 49 N·m (5.0 kgf·m, 36 lbf·ft)**

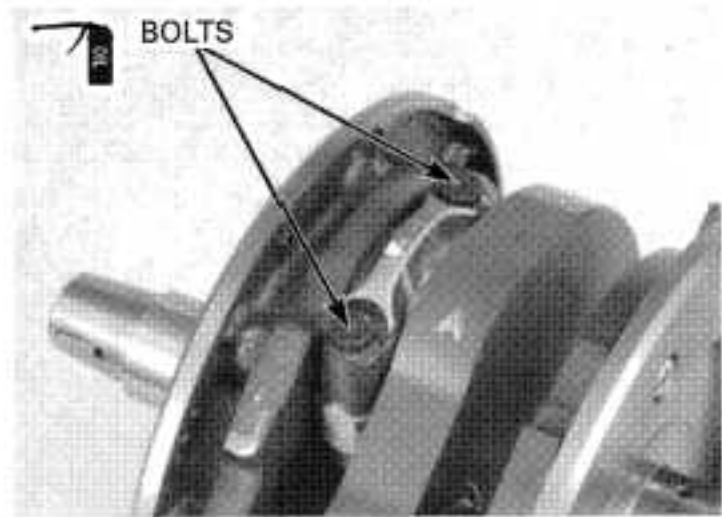

Remove the bearing caps and measure the compressed plastigauge at its widest point on each crankpin to determine the oil clearance.

**SERVICE LIMIT: 0.070 mm (0.0028 in)**

If the clearance exceeds the service limit, select the correct replacement bearings as follows.

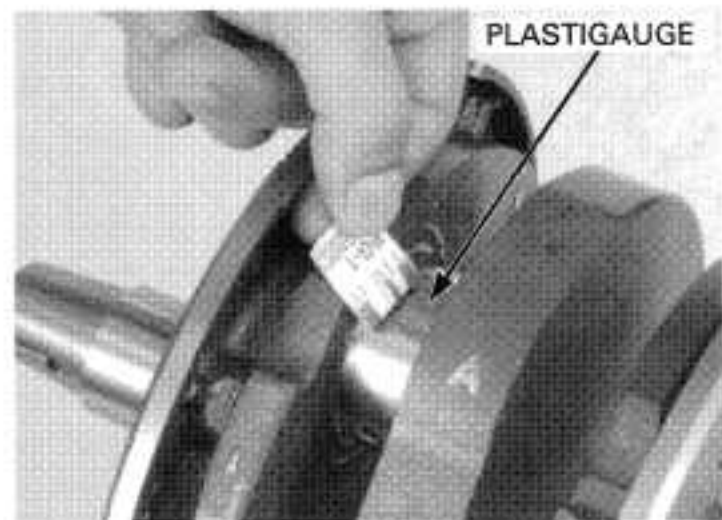

### CONNECTING ROD BEARING SELECTION

Record the connecting rod I.D. code number.

- Number 1 or 2 on the connecting rod is the code for the connecting rod I.D.

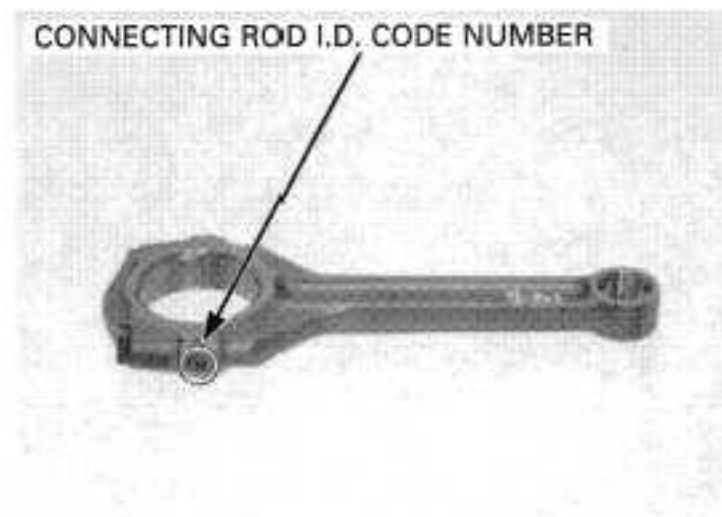

Record the crankpin O.D. code letter.

- Mark A or B on each crank weight is the code for the crankpin O.D.

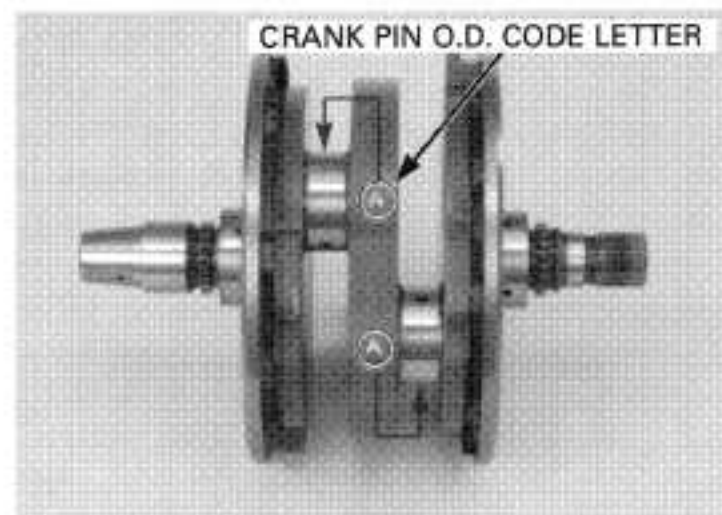

Cross reference the connecting rod and crankpin codes to determine the replacement bearing color code.

Connecting rod I.D. code		1	2
		55.000 – 55.008 mm (2.1654 – 2.1657 in)	55.008 – 55.016 mm (2.1657 – 2.1660 in)
Crankpin O.D. code	A	Pink	Yellow
	B	Yellow	Green

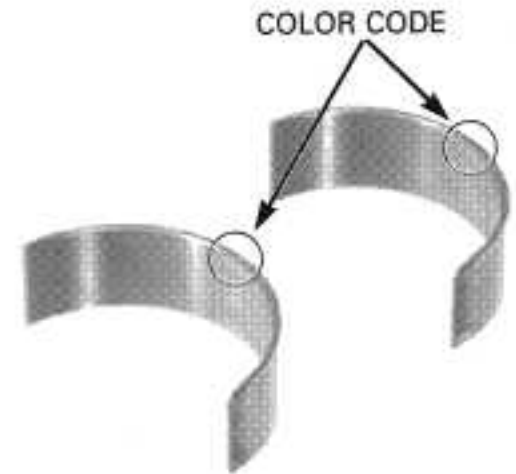

**Connecting rod bearing thickness:**

- Green:**  
1.495 – 1.499 mm (0.0589 – 0.0590 in): Thick
- Yellow:**  
1.491 – 1.495 mm (0.0587 – 0.0589 in)
- Pink:**  
1.487 – 1.491 mm (0.0585 – 0.0587 in): Thin



**MAIN BEARING INSPECTION**

Clean any oil from the bearings and crankshaft journal.

Measure and record the crankshaft main journal O.D.

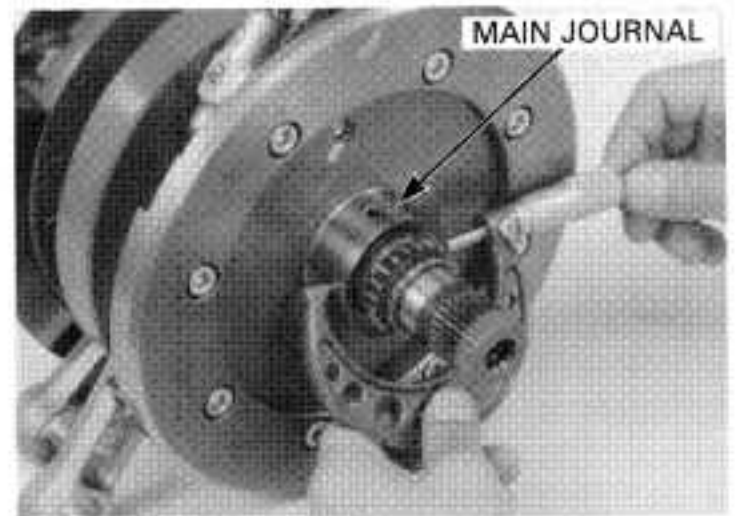

*Be careful not to damage the inside of the bearing during inspection.*

Measure and record the main bearing I.D. in the crankcase.

Calculate the clearance between the main journal and main bearing.

**SERVICE LIMIT: 0.068 mm (0.0027 in)**

If the oil clearance exceeds the service limit, replace the crankcase.

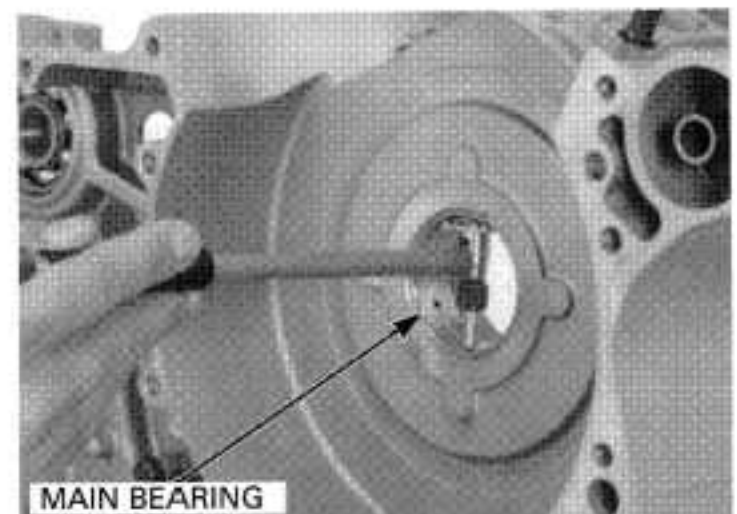

## CONNECTING ROD SELECTION

An alphabetical weight code is stamped on the connecting rod.

If a connecting rod requires replacement, you should select a rod with the same weight code as the original. But if that is unavailable, you may use one of the others specified in the following chart.

- The "O" mark in the table indicates that mating is possible in the crossed codes.

FRONT ROD CODE \ REAR ROD CODE	A	B	C	D
A	O	O		
B	O	O	O	
C		O	O	O
D			O	O

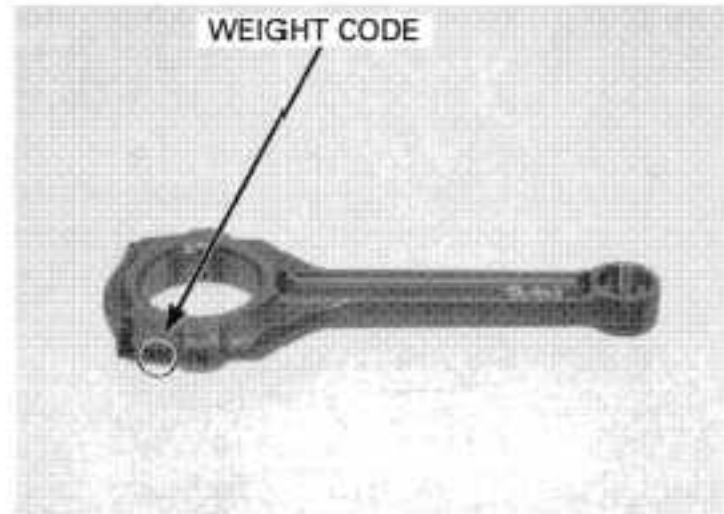

## CONNECTING ROD INSTALLATION

Wipe any oil from the connecting rod, cap and bearing inserts.

Install the bearing inserts on the connecting rods and caps by aligning the tab with the groove.

Apply molybdenum oil solution to the thrust surface of the bearings.

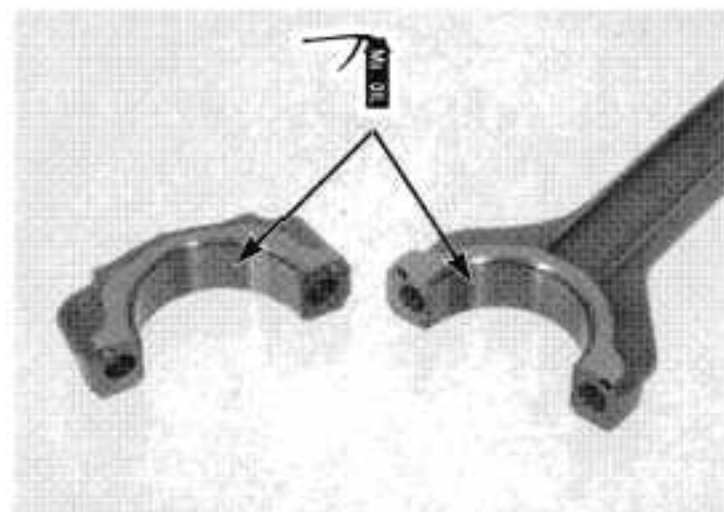
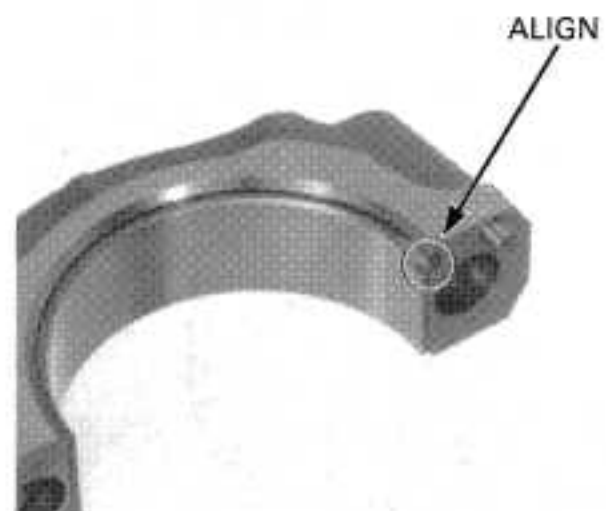

Install the rods and caps on the crankshaft by aligning the I.D. code on the rod and cap. Be sure each part is installed in its original position, as noted during removal.

Apply engine oil to the bearing cap bolt threads and tighten the them in two or more steps alternately.

**TORQUE: 49 N·m (5.0 kgf·m, 36 lbf·ft)**

After tightening the bolts, check that the connecting rods move freely without binding.

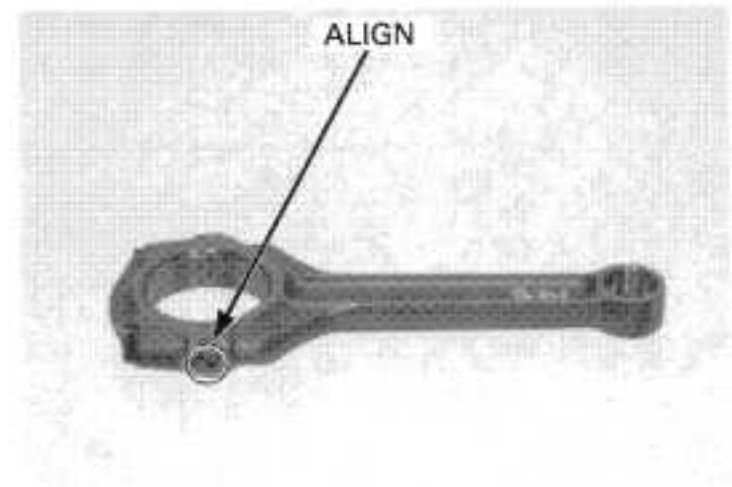
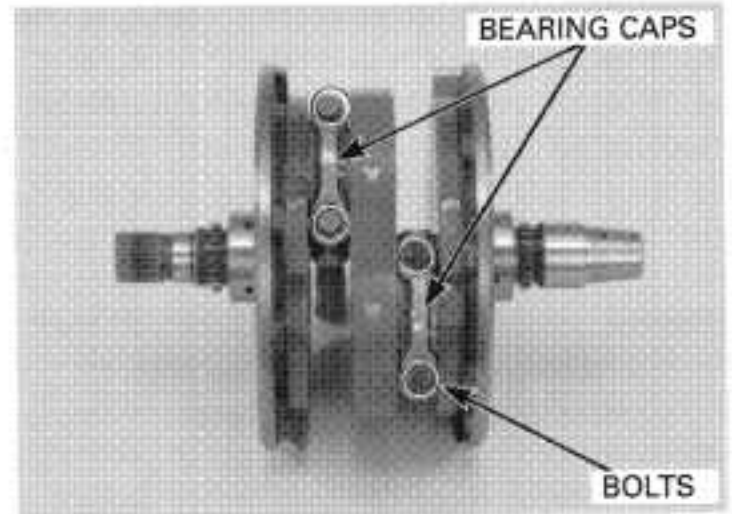

Apply molybdenum oil solution to the main bearing inserts and install the crankshaft into the left crankcase.

Assemble the crankcase (page 11-17).

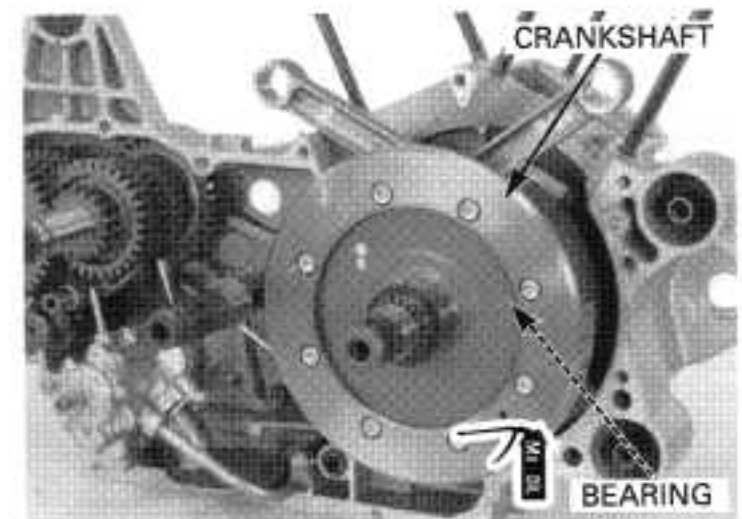

## TRANSMISSION

### REMOVAL

Separate the crankcase (page 11-4).  
Remove the oil pump (page 4-3).

Pull the shift fork shaft up and remove it from the shift forks.

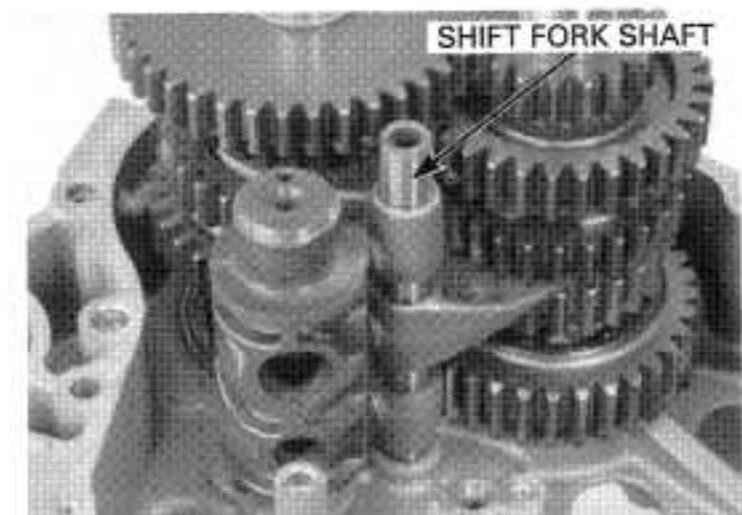



## CRANKSHAFT/TRANSMISSION

Remove the shift drum and shift forks.

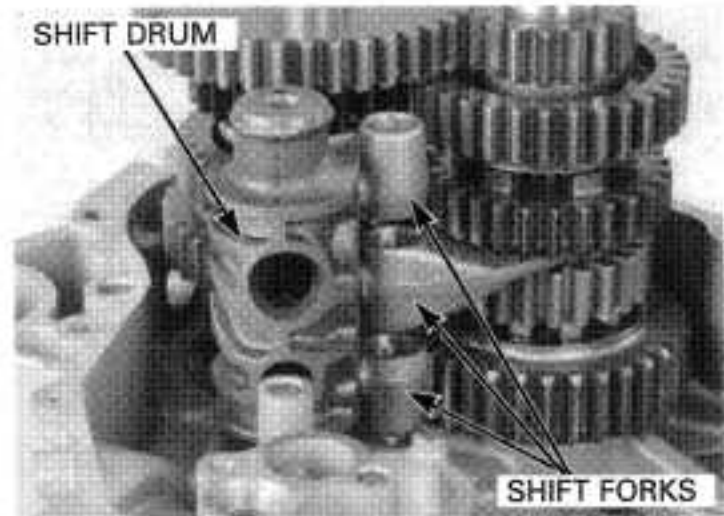

Remove the washer, C1 gear, C4 gear, collars and needle bearing from the countershaft.



Remove the C2 gear, C3 gear, C5 gear and collar from the countershaft.  
Remove the mainshaft as an assembly.

Remove the output gear assembly (page 11-19).

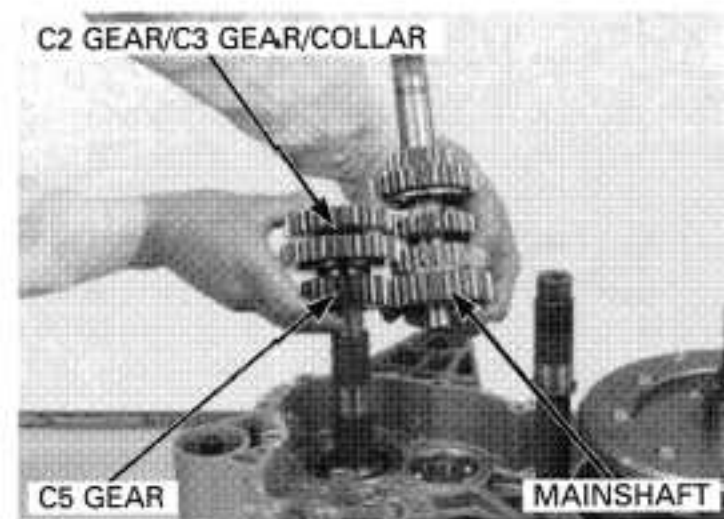

### DISASSEMBLY

Disassemble the mainshaft.

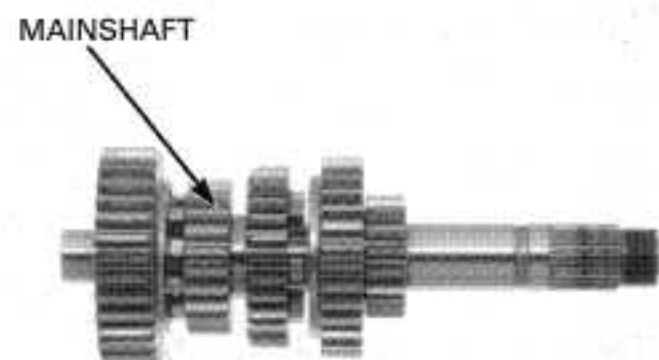



**INSPECTION**

**GEARS**

Check the gear dogs, dog holes and teeth for damage or excessive wear.

Measure the I.D. of each gear.

**SERVICE LIMITS:**

- M4, M5 gears: 31.035 mm (1.2218 in)
- C1 gear: 30.035 mm (1.1825 in)
- C2/C3 gears: 33.035 mm (1.3006 in)

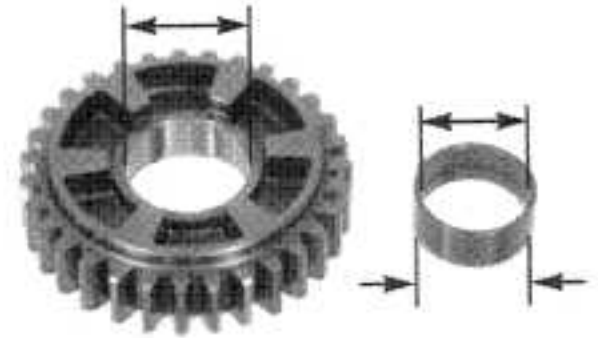

**BUSHING**

Check the bushings for wear or damage.

Measure the O.D. of each bushing.

**SERVICE LIMITS:**

- M4, M5 gear bushings: 30.94 mm (1.218 in)
- C1 gear bushing: 25.977 mm (1.0227 in)
- C2/C3 gear bushing: 32.94 mm (1.297 in)

Measure the I.D. of each bushing.

**SERVICE LIMITS:**

- M4 gear bushing: 28.03 mm (1.104 in)
- C1 gear bushing: 22.170 mm (0.8728 in)
- C2/C3 gear bushing: 30.050 mm (1.1831 in)

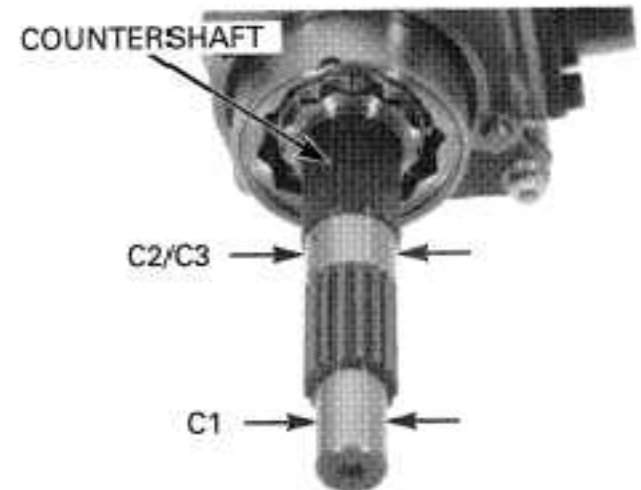

**MAINSHAFT/COUNTERSHAFT**

Check the spline grooves and sliding surfaces for abnormal wear or damage.

Measure the O.D. of the mainshaft and countershaft at the gear and bushing sliding areas.

**SERVICE LIMITS:**

- Mainshaft**
- (at M4 gear): 27.940 mm (1.1000 in)
- (at clutch outer guide): 27.970 mm (1.1012 in)
- Countershaft**
- (at C1 gear): 21.97 mm (0.865 in)
- (at C2/C3 gear): 29.94 mm (1.179 in)

Calculate the gear-to-bushing and bushing-to-shaft clearance.

**SERVICE LIMITS:**

- Gear-to-bushing (M4, M5):** 0.095 mm (0.0037 in)
- (C2/C3): 0.095 mm (0.0037 in)
- Bushing-to-shaft (M4)** 0.067 mm (0.0026 in)
- (C1) 0.190 mm (0.0075 in)
- (C2/C3) 0.091 mm (0.0036 in)

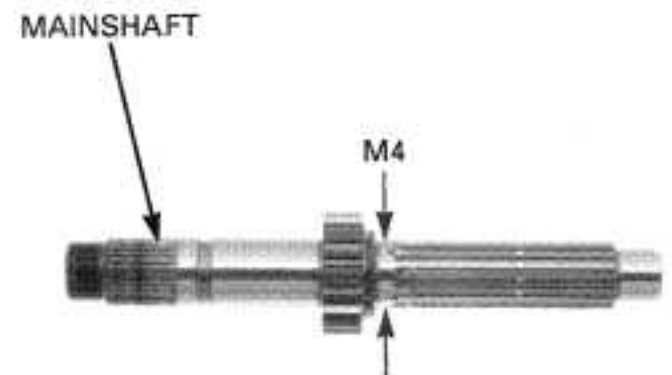

## CRANKSHAFT/TRANSMISSION

---

### SHIFT FORK

Check for deformation or abnormal wear.

Measure the shift fork claw thickness.

**SERVICE LIMIT: 5.83 mm (0.230 in)**

Measure the shift fork I.D.

**SERVICE LIMIT: 14.04 mm (0.553 in)**

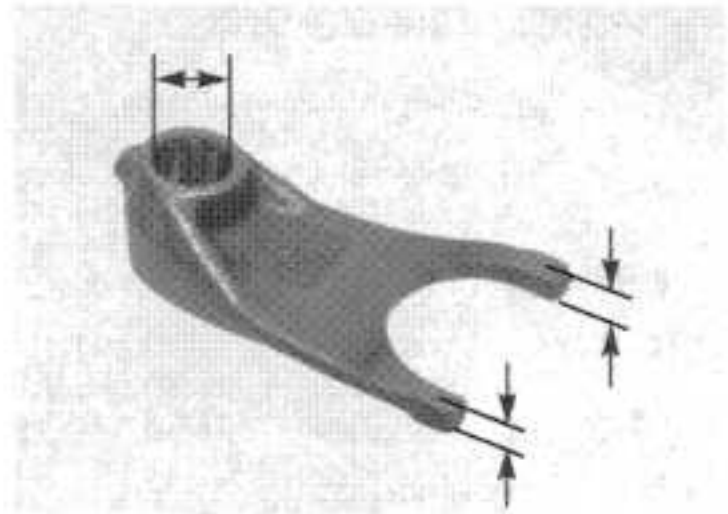

### SHIFT FORK SHAFT

Check for bends, abnormal wear or damage.

Measure the shift fork shaft O.D.

**SERVICE LIMIT: 13.956 mm (0.5494 in)**

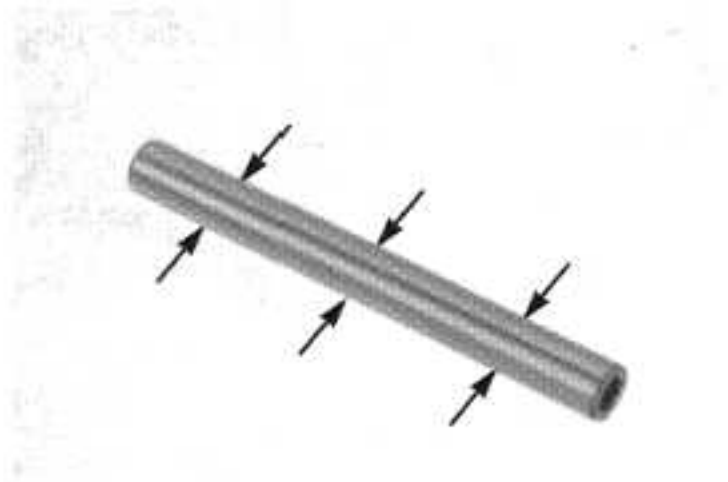

### SHIFT DRUM

Inspect the shift drum end for scoring, scratches, or evidence of insufficient lubrication.  
Check the shift drum grooves for abnormal wear or damage.

SHIFT DRUM



### SHIFT DRUM BEARING AND JOURNAL

Check the shift drum bearing on the left crankcase for excessive play or damage.

Check the shift drum journal in the left crankcase for excessive wear or damage.

**ASSEMBLY**

Clean all parts in solvent.

Apply molybdenum oil solution to the bushing sliding surface and shift fork grooves to ensure initial lubrication.

Apply engine oil to every gear to ensure initial lubrication.

Assemble all parts into their original positions.

- Check the gears for smooth movement or rotation on the shaft.
- Install the washers and snap rings with the chamfered edges facing the thrust load side. Do not reuse a worn snap ring which could easily spin in the groove.
- Check that the snap rings are seated in the grooves and align their end gaps with the grooves of the spline.

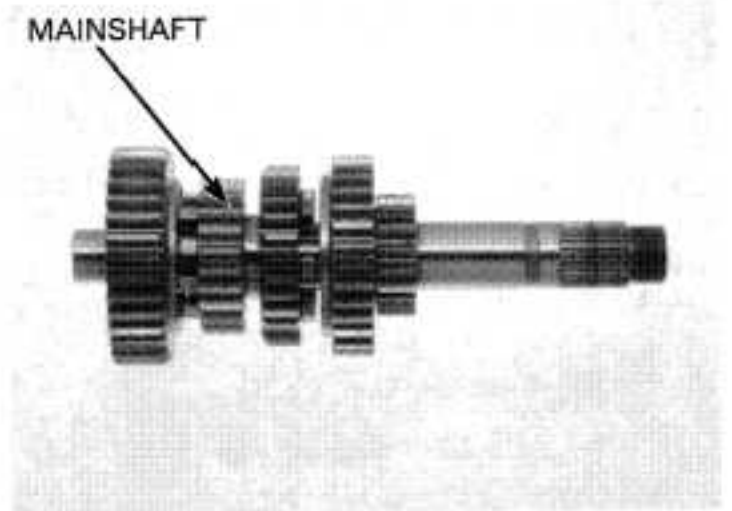

**MAINSHAFT**

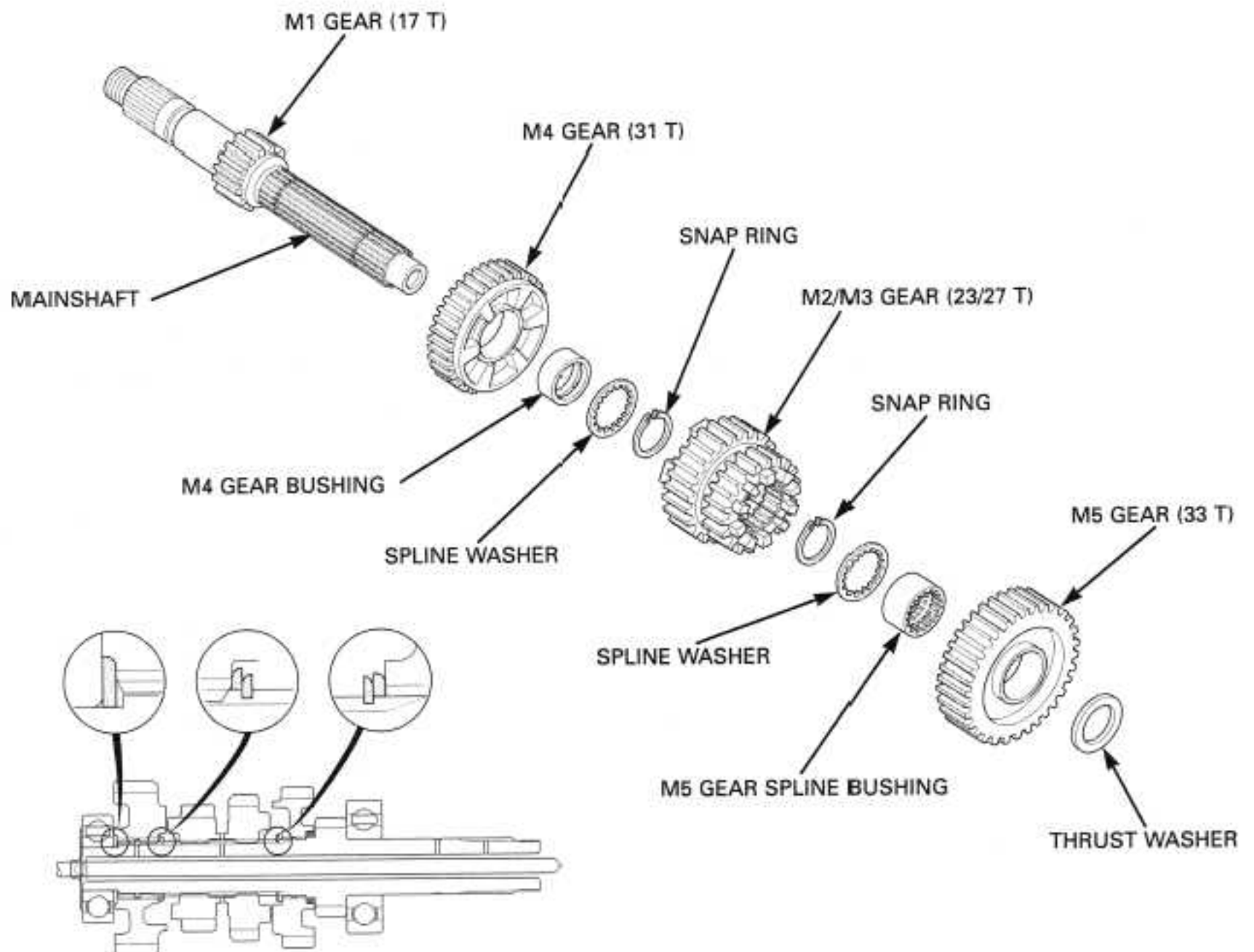

# CRANKSHAFT/TRANSMISSION

## COUNTERSHAFT/OUTPUT GEAR

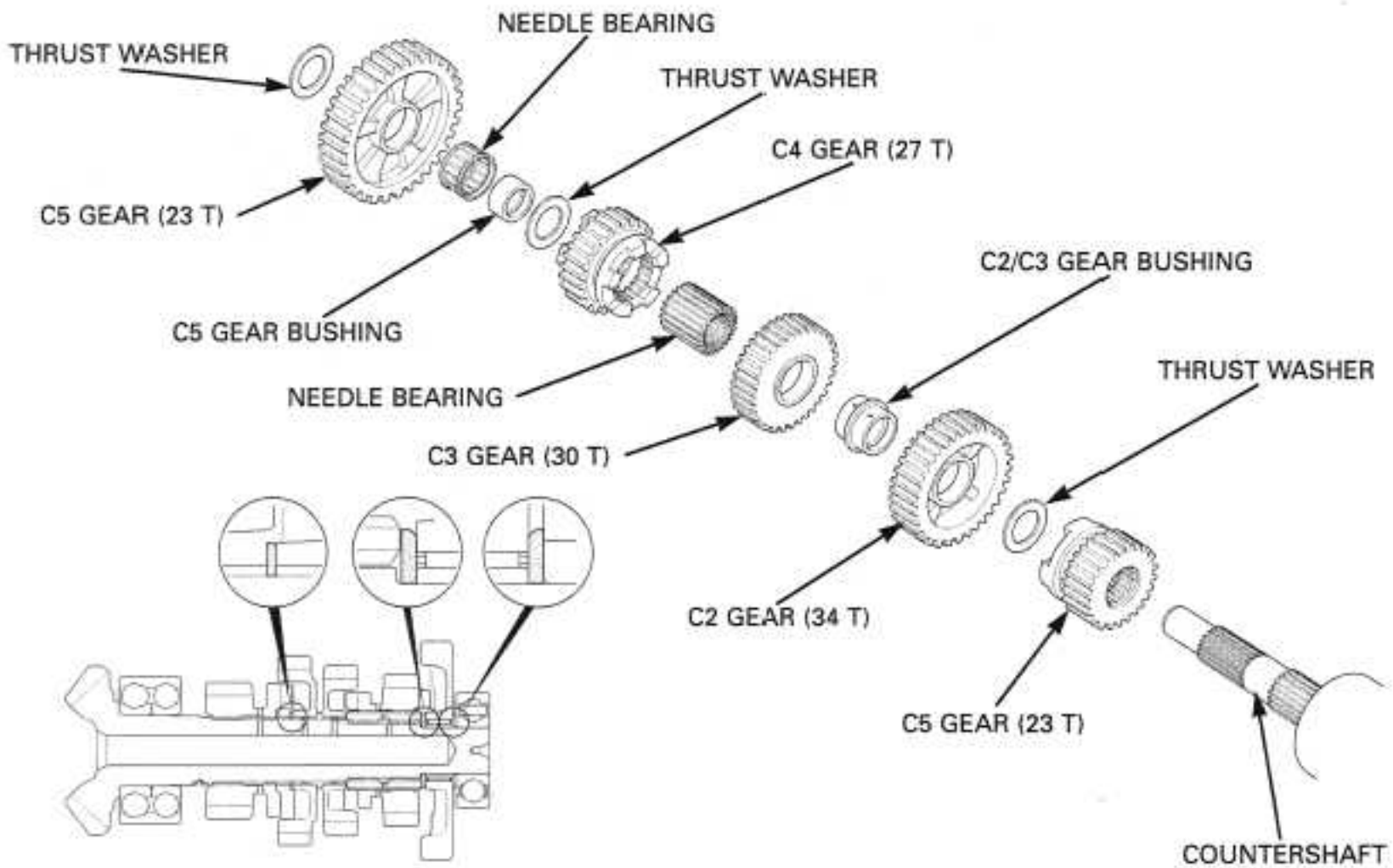

## INSTALLATION

Install the output gear assembly (page 11-24).

Install the mainshaft to the left crankcase as an assembly.

Install the collar, C5 gear, C3 gear, C2 gear to the countershaft.

Install the needle bearing, collars, C4 gear, C1 gear to the countershaft.

Check the mainshaft and countershaft installation.

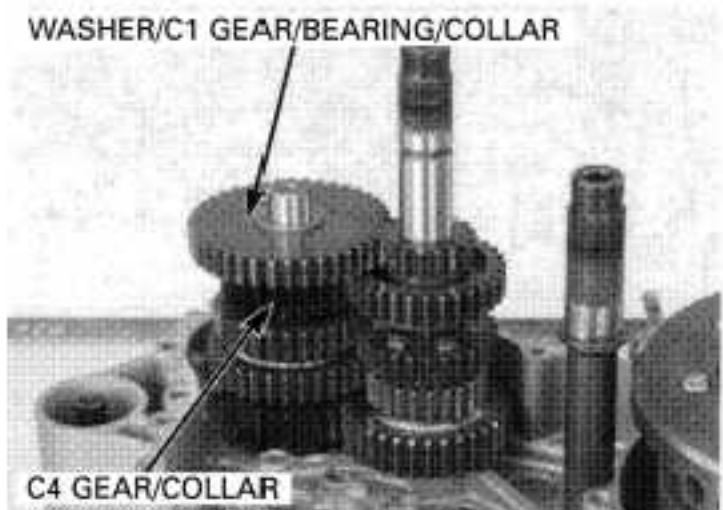
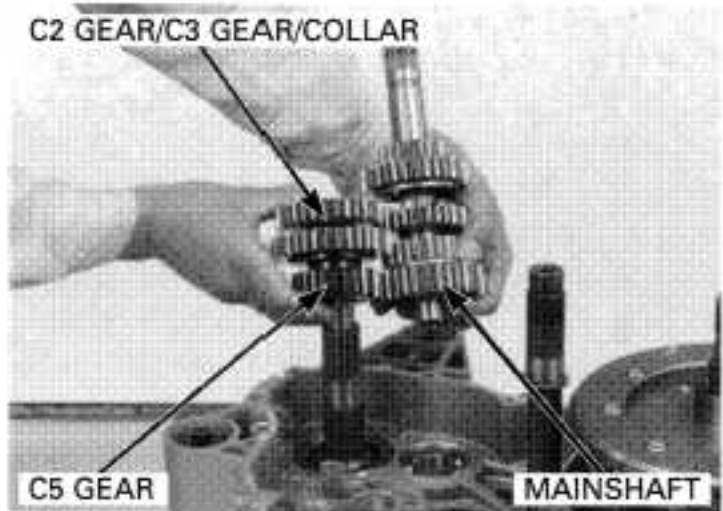

Install the shift forks into the shifter gear grooves with the marked side facing up (right crankcase side).  
Install the shift drum by aligning the shift fork guide pins with the shift drum guide grooves.

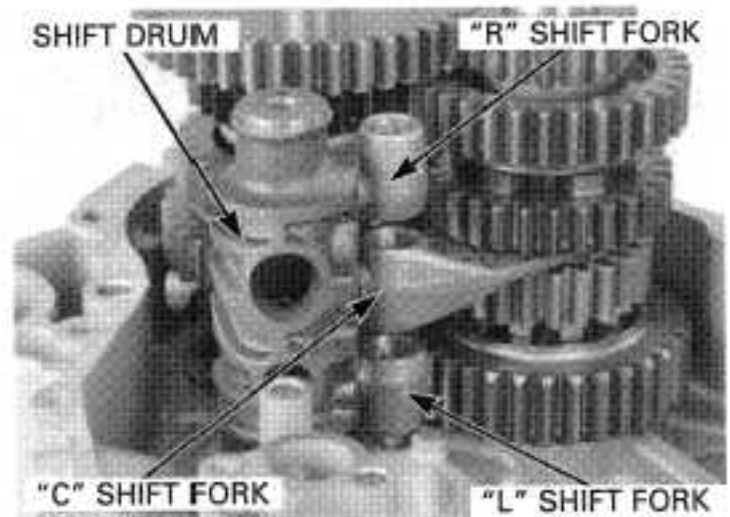
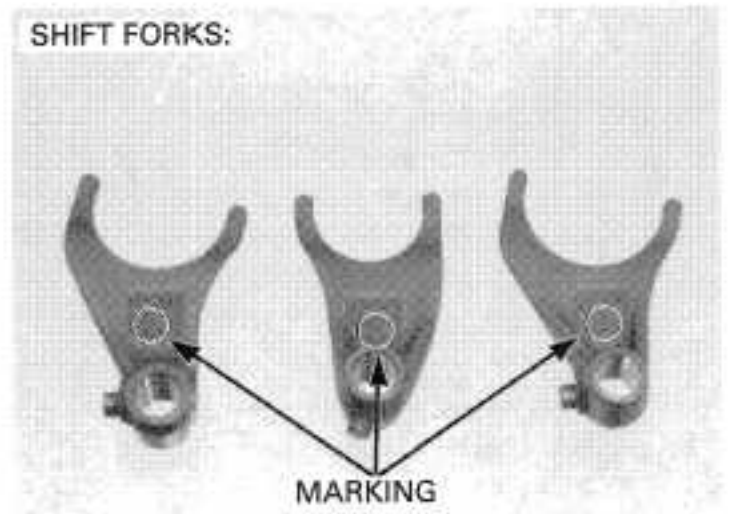

Apply engine oil to the shift fork shaft and install it through the shift forks into the left crankcase.

After installing, check for smooth transmission operation.

Assemble the crankcase (see below).

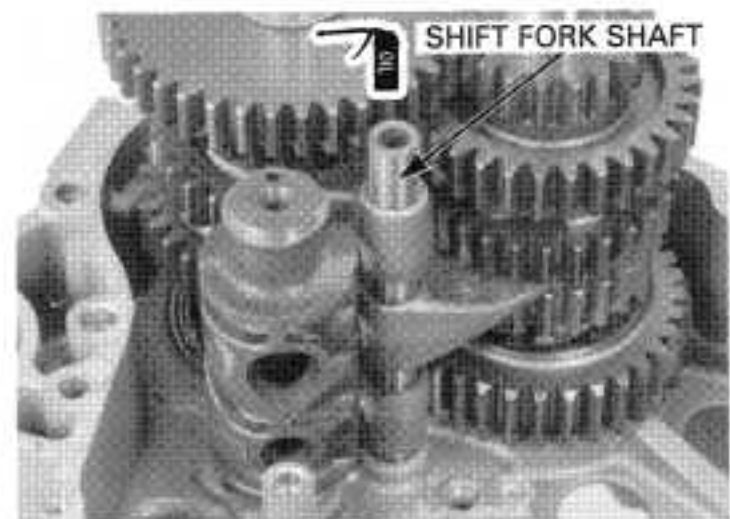

## CRANKCASE ASSEMBLY

Clean the left and right crankcase mating surfaces thoroughly, being careful not to damage them.

Make sure all parts are installed in the left and right crankcase.

Apply liquid sealant to the crankcase mating surfaces.

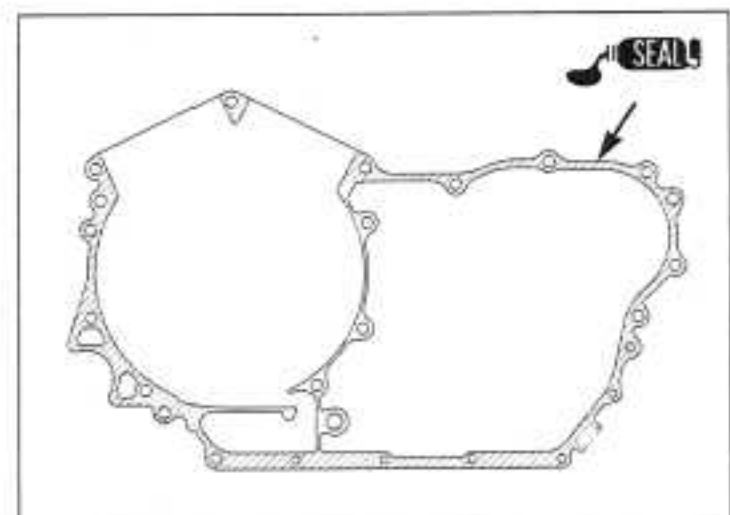



## CRANKSHAFT/TRANSMISSION

Install the crankshaft to the left crankcase (page 11-11).

Install the transmission to the left crankcase (page 11-16).

Install the primary shaft to the left crankcase (page 11-5).

Install the oil pump to the left crankcase (page 4-9).

Apply engine oil to a new O-ring.

Install the dowel pins and O-ring into the left crankcase.

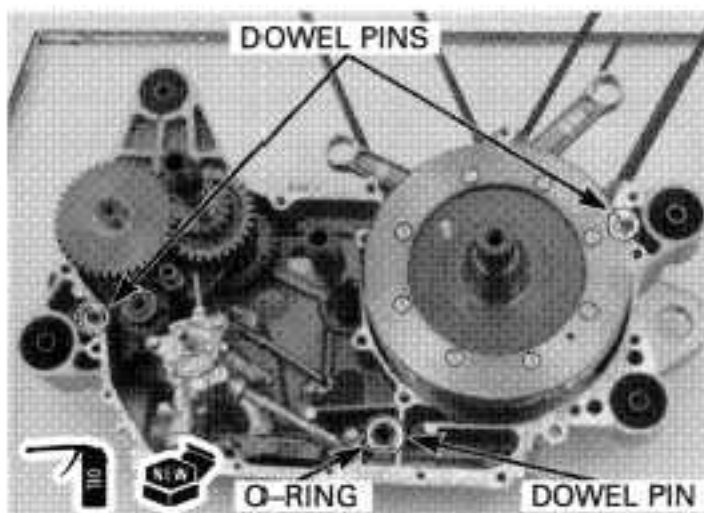

Install the right crankcase over the left crankcase.

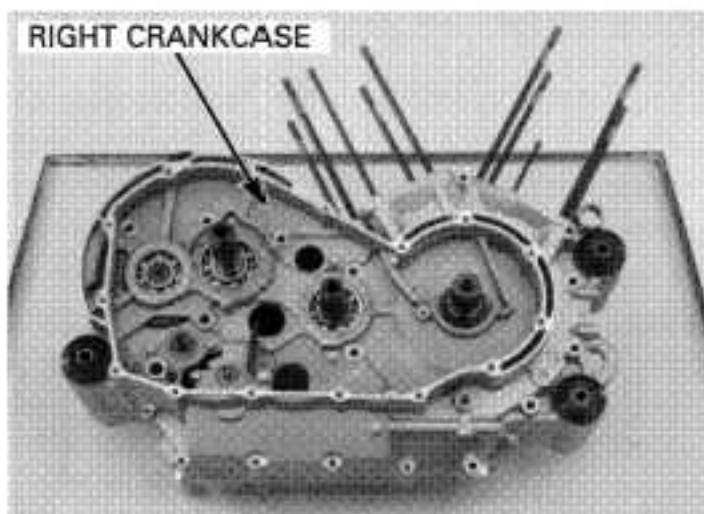

Install and tighten the left crankcase bolts with the new washers to the specified torque.

**TORQUE: 26 N·m (2.7 kgf·m, 20 lbf·ft)**

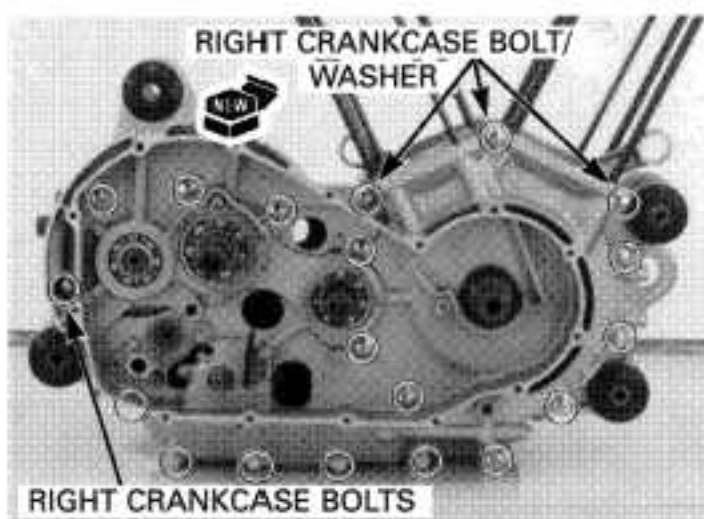

Install and tighten the right crankcase bolt to the specified torque.

**TORQUE: 26 N·m (2.7 kgf·m, 20 lbf·ft)**

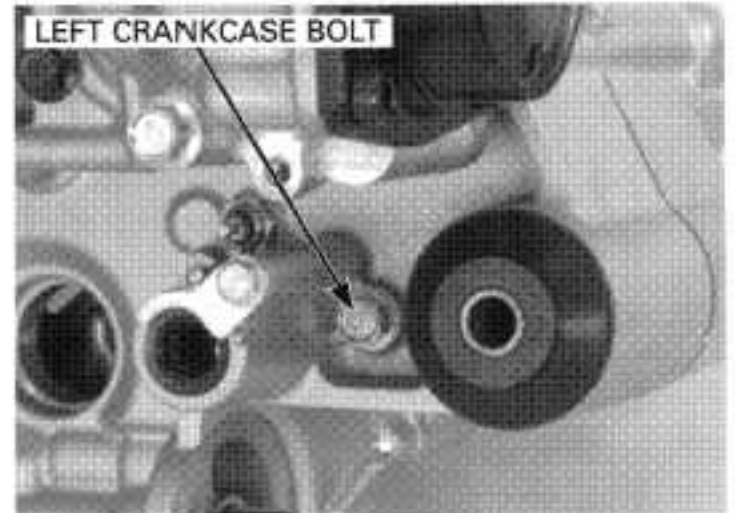

Install the cam chains onto the drive sprockets.

Install the remaining parts.

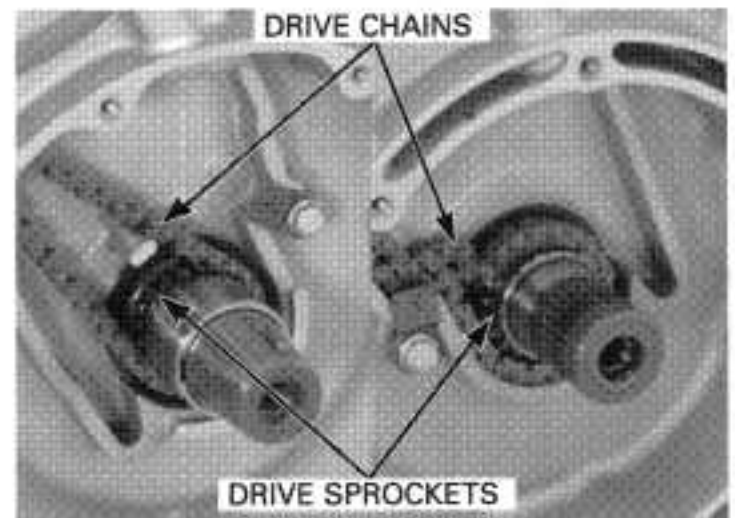

## OUTPUT GEAR

Description of the output gear assembly:

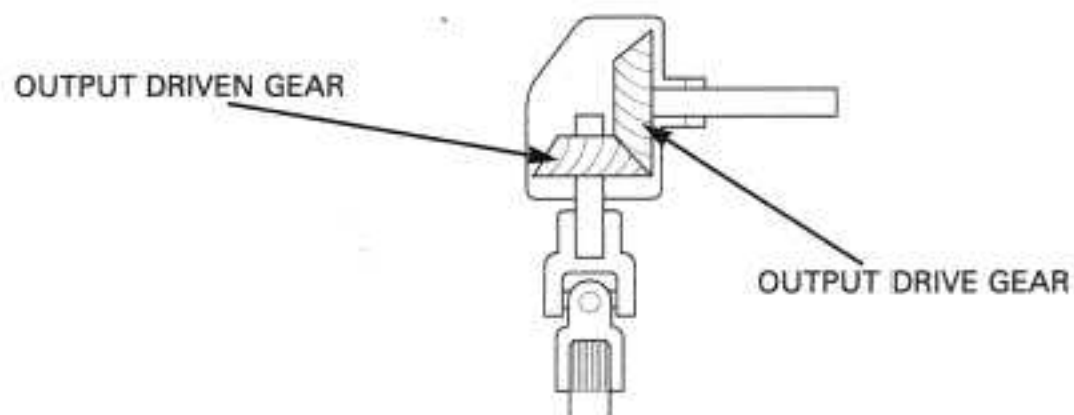

### REMOVAL

Separate the crankcase (page 11-4).  
Remove the transmission (page 11-11).

Remove the bolts and the output gear assembly.

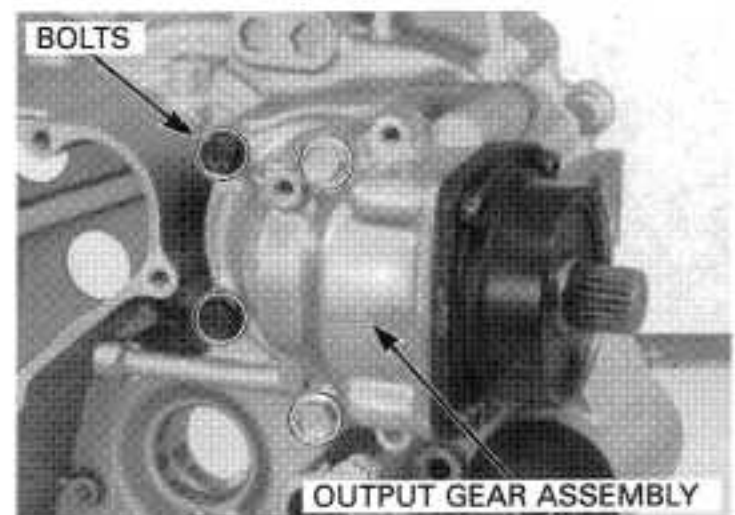

## CRANKSHAFT/TRANSMISSION

Remove the oil orifice and O-rings.

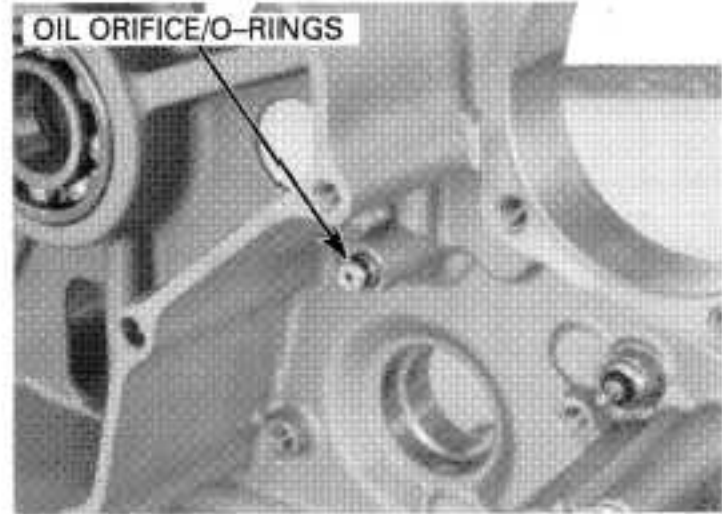

### BACKLASH INSPECTION/GEAR TOOTH CONTACT PATTERN CHECK

- Perform the backlash inspection and contact pattern check whenever you replace the countershaft/output drive gear and output driven gear, bushings, bearing holder and gear case. The extension lines from the gear engagement surfaces should intersect at one point.

#### BACKLASH INSPECTION

Clamp the output gear case in a vice that has soft jaws or use a shop towel.

Set the horizontal type dial indicator on the countershaft/output drive gear as shown.

Hold the output driven gear shaft with the shaft holder and rotate the countershaft/output drive gear until gear slack is taken up.

#### TOOLS:

Mainshaft holder                      07923-6890101

Turn the countershaft/output drive gear back and forth to read the backlash.

**STANDARD:**     0.08 - 0.23 mm (0.003 - 0.009 in)

**SERVICE LIMIT:** 0.40 mm (0.016 in)

Remove the dial indicator. Turn the countershaft/output drive gear 120° and measure the backlash. Repeat this procedure once more.

Compare the difference of the three measurements.

#### Backlash difference between measurements

**SERVICE LIMIT:** 0.10 mm (0.004 in)

If the difference in measurements exceeds the limit, it indicates that the bearings must be replaced and reshimmed.

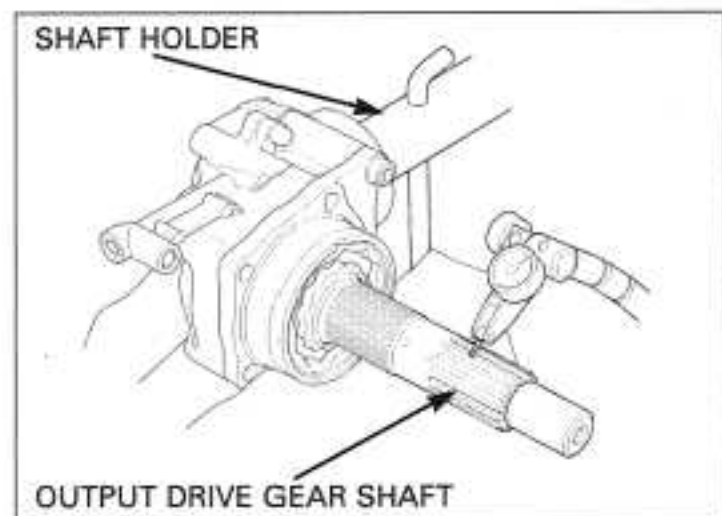
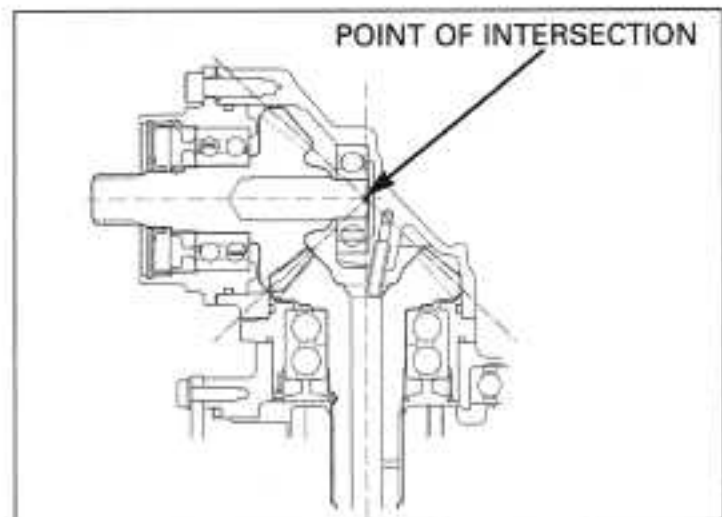

If the backlash is excessive, replace the countershaft/output drive gear adjustment shim with a thinner one.

If the backlash is too small, replace the countershaft/output drive gear adjustment shim with a thicker one.

Backlash is changed by about 0.06 – 0.07 mm (0.002 – 0.003 in) when shim thickness is changed by 0.10 mm (0.004 in).

**Output drive gear adjustment shims:**

- A: 0.40 mm (0.016 in)
- B: 0.45 mm (0.018 in)
- C: 0.50 mm (0.020 in) — Standard
- D: 0.55 mm (0.022 in)
- E: 0.60 mm (0.024 in)

To replace the shim, remove the countershaft/output drive gear and bearing holder as an assembly from the gear case.

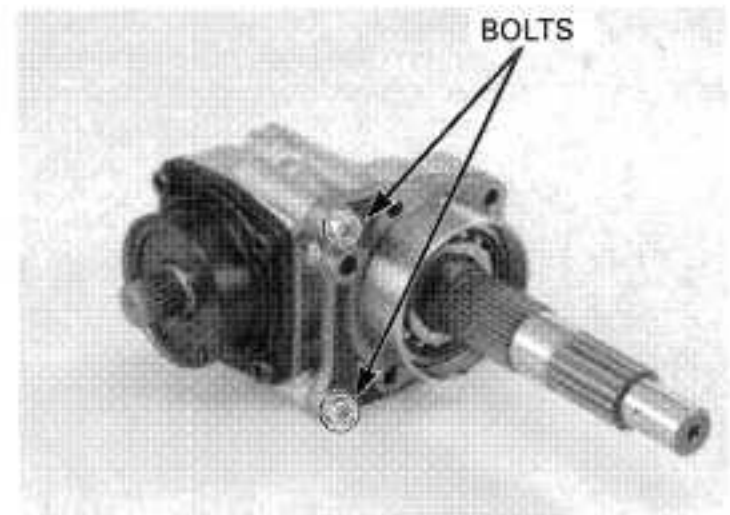
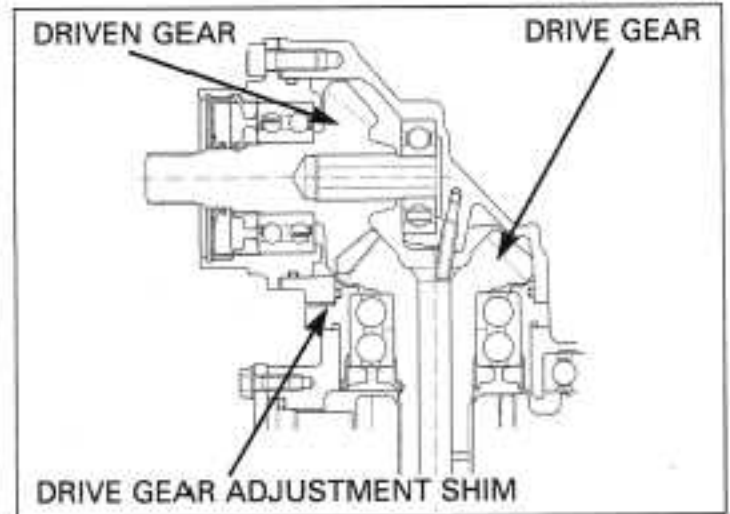

Replace the shim.

Coat a new gear holder O-ring with engine oil and install it into the gear holder groove. Install the adjustment shim over the bearing holder.

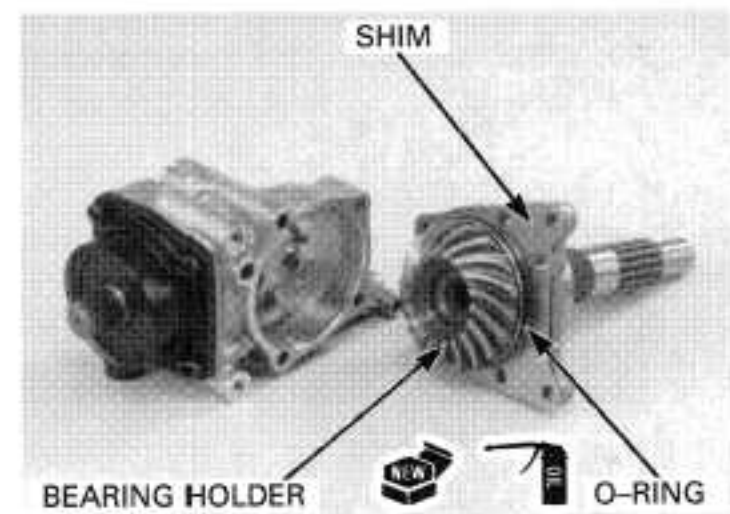

Set the bearing holder into the gear case. Apply engine oil to the gear holder bolt threads. Tighten the gear holder bolts to the specified torque.

**TORQUE: 31 N·m (3.2 kgf·m, 23 lbf·ft)**

After the backlash adjustments has been made, check the gear tooth contact pattern described next page.

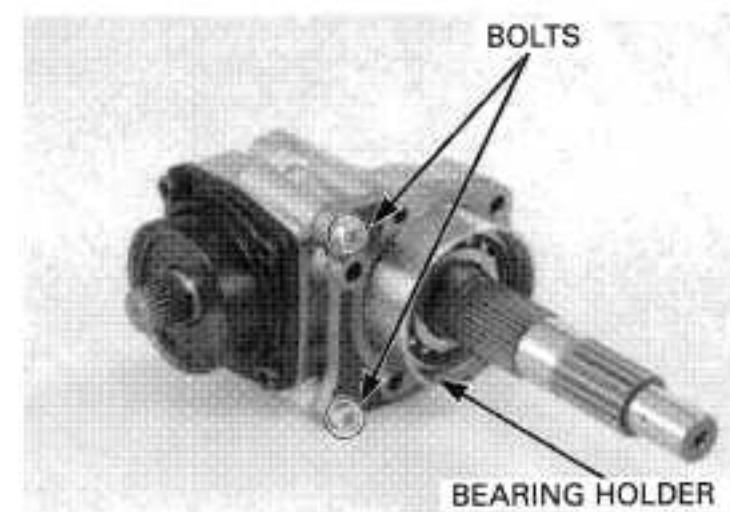



## CRANKSHAFT/TRANSMISSION

### GEAR TOOTH CONTACT PATTERN CHECK

Description of the tooth:

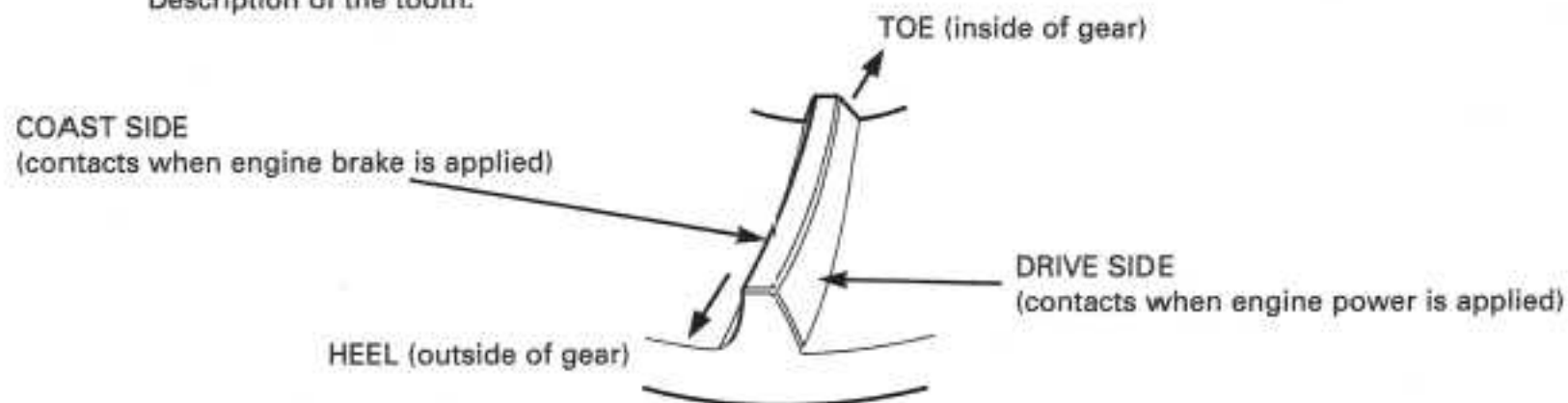

Remove the countershaft/output drive gear from the gear case (page 11-19).

Apply Prussian Blue to the output driven gear teeth.

Reinstall the countershaft/output drive gear to the gear case.

Rotate the countershaft/output drive gear several times in the normal direction of rotation.

Remove the countershaft/output drive gear and check the gear tooth contact pattern as described on the following page.

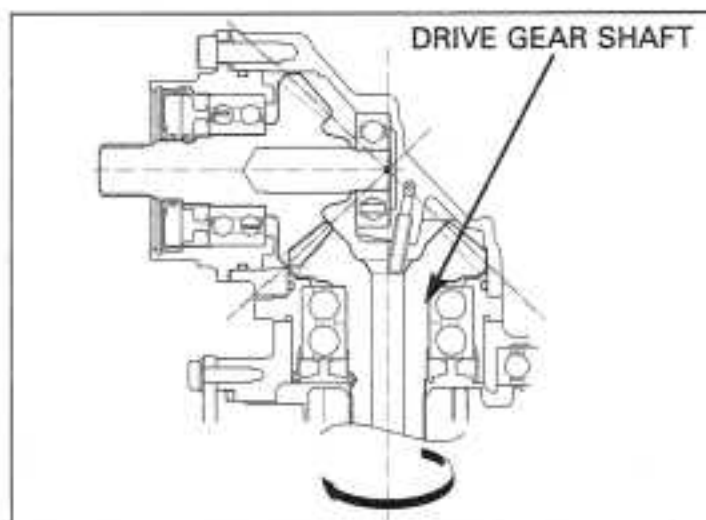

Contact is normal if Prussian Blue is transferred to the approximate center of each tooth and slightly to the toe.

If the pattern is not correct, remove and replace the countershaft/output driven gear adjustment shim.

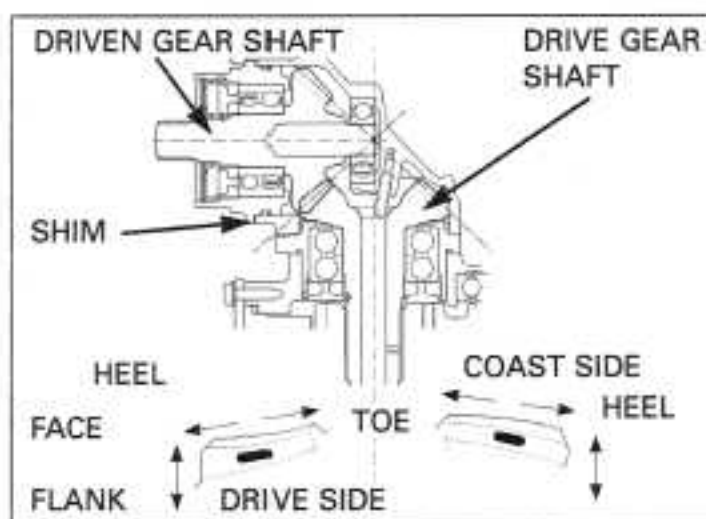

Replace the shim with a thinner one if the contact pattern is too high.

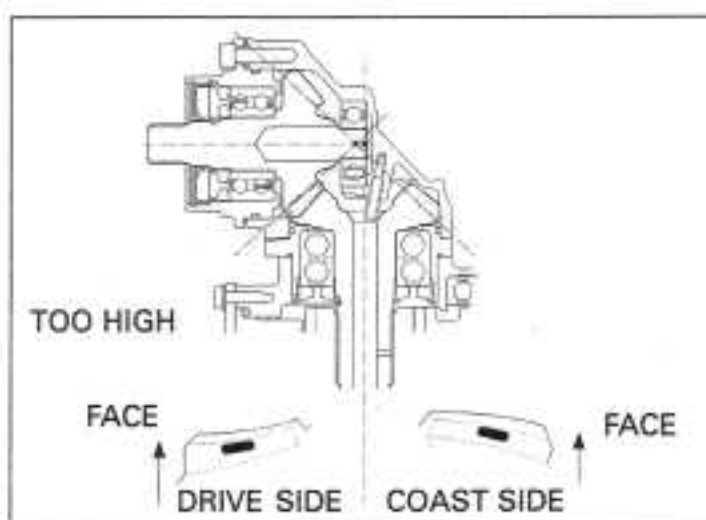



Replace the shim with a thicker one if the contact pattern is too low.

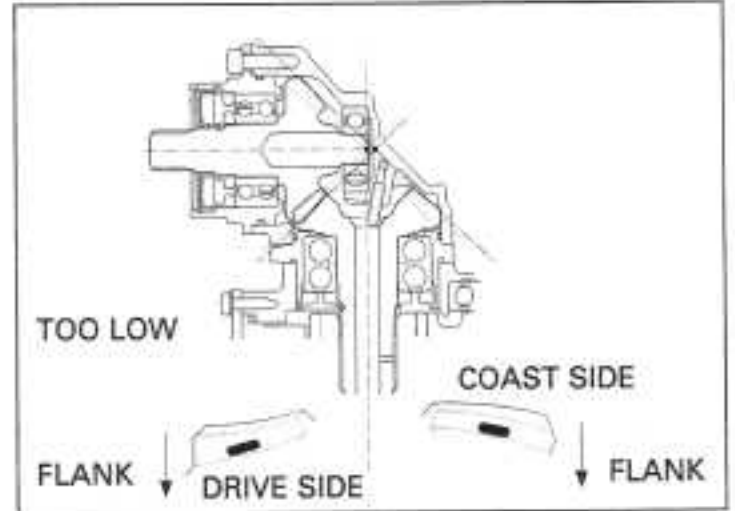

The pattern will shift about 1.5 – 2.0 mm (0.06 – 0.08 in) when the shim thickness is changed by 0.10 mm (0.04 in).

**Output driven gear adjustment shims:**

- A: 0.20 mm (0.008 in)    F: 0.45 mm (0.018 in)
- B: 0.25 mm (0.010 in)    G: 0.50 mm (0.020 in)
- C: 0.30 mm (0.012 in)    H: 0.55 mm (0.022 in)
- D: 0.35 mm (0.014 in)    I: 0.60 mm (0.024 in)
- E: 0.40 mm (0.016 in) — Standard

To replace the shim, remove the driven gear and bearing holder as an assembly from the gear case.

Replace the shim.

Coat a new gear holder O-ring with the engine oil and install it into the gear holder groove. Install the adjustment shim over the bearing holder.

- When the bearing, gear, holder and/or case have been replaced, use the 0.4 mm (0.016 in) shim for initial reference.

Align the bolt holes in the gear holder and shim, then install them into the gear case.

Apply engine oil to the threads and seating surface of the bearing holder socket bolts and tighten them.

**TORQUE: 31 N·m (3.2 kgf·m, 23 lbf·ft)**

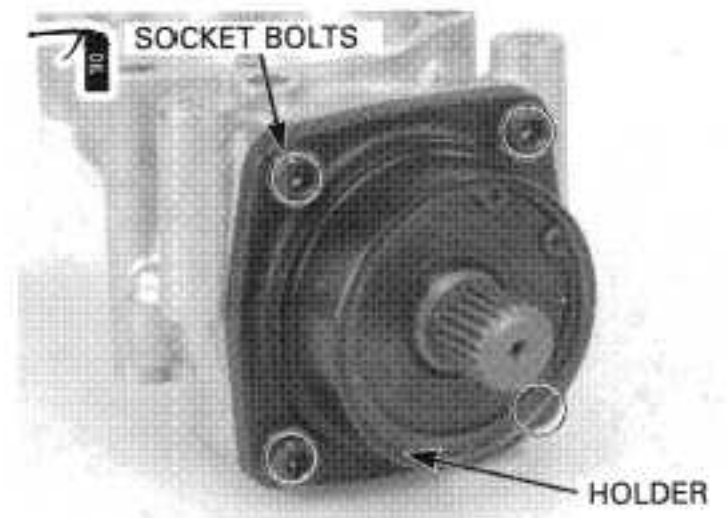
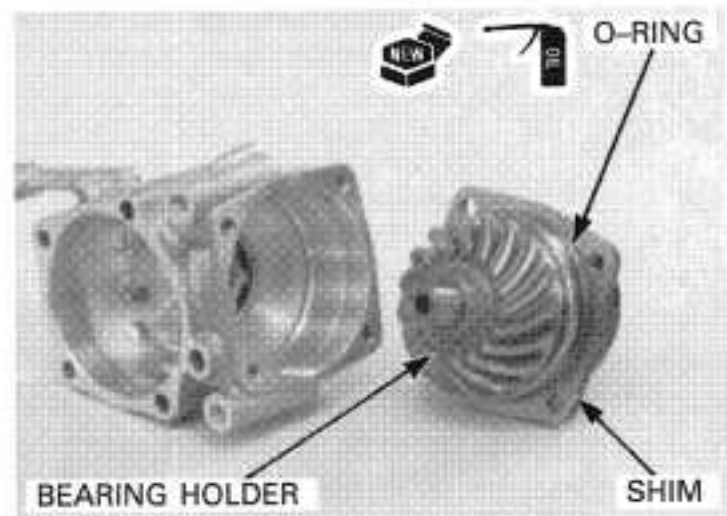
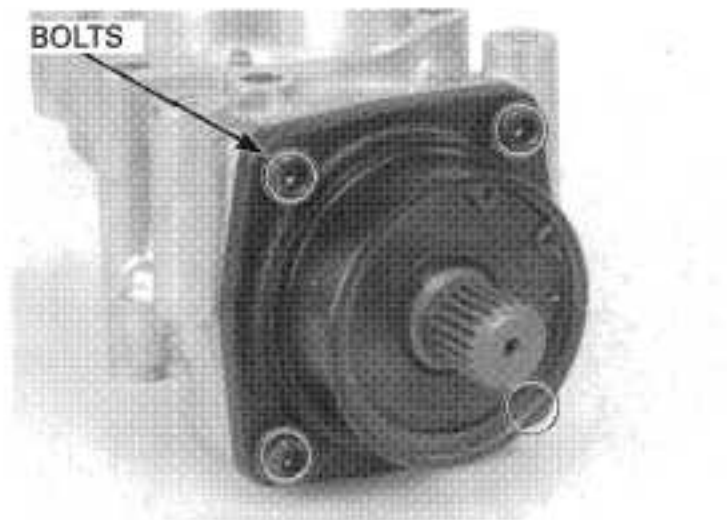

### CASE BEARING REPLACEMENT

Remove the countershaft/output drive gear and bearing holder as an assembly (page 11-21).  
Remove the driven gear and bearing holder as an assembly (page 11-23).

*Always wear insulated gloves when handling a heated gear case.*

Heat the output gear case around the driven gear case bearing to 80 °C (176 °F).

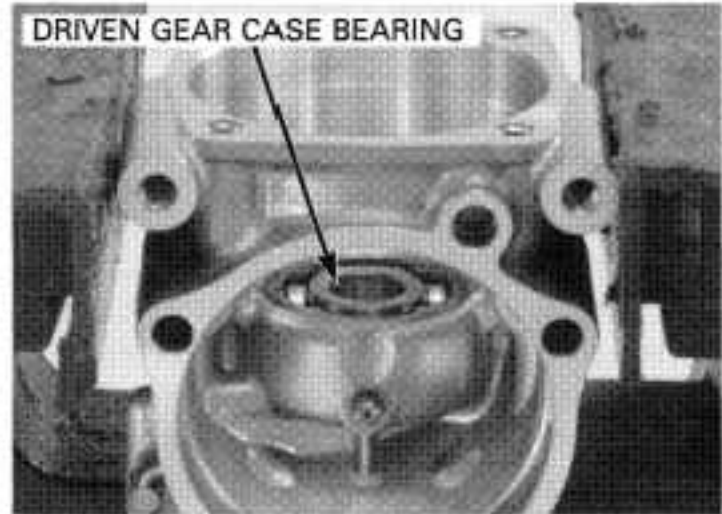

Remove the driven gear case bearing using the special tools.

#### TOOLS:

Remover handle  
Bearing remover  
Remover weight

07736-3710100  
07736-3710300  
07936-371020A or  
07936-3710200

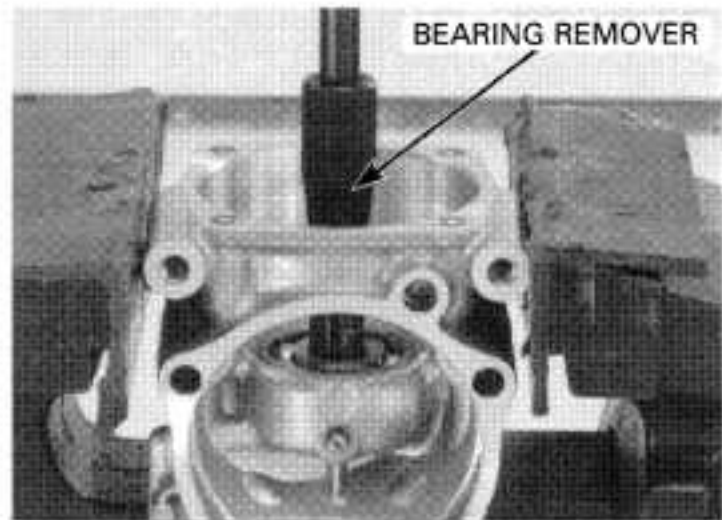

Drive a new bearing into the gear case using the special tools as shown.

#### TOOLS:

Driver  
Attachment, 42 x 47 mm  
Pilot, 17 mm

07749-0010000  
07746-0010300  
07746-0040400

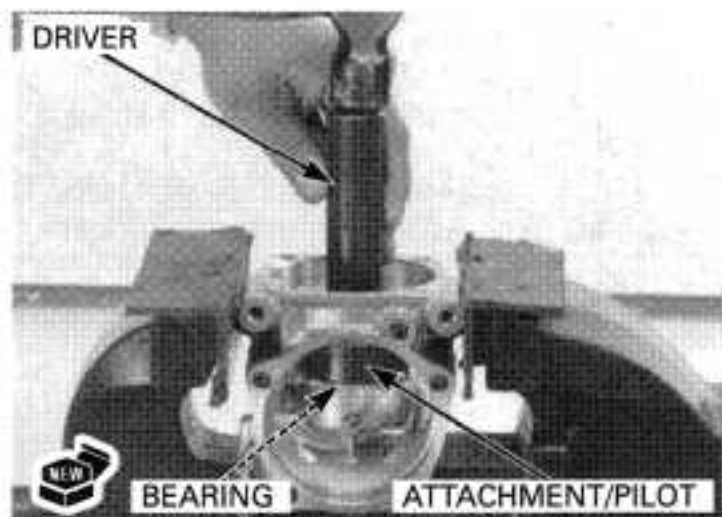

### INSTALLATION

Coat new orifice O-rings with engine oil and install them into the orifice grooves.

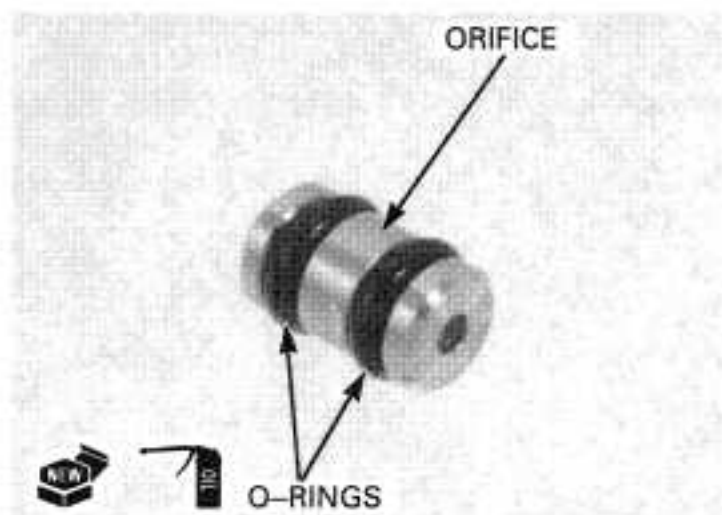

Install the orifice into the crankcase with the chamfered hole side facing the crankcase.

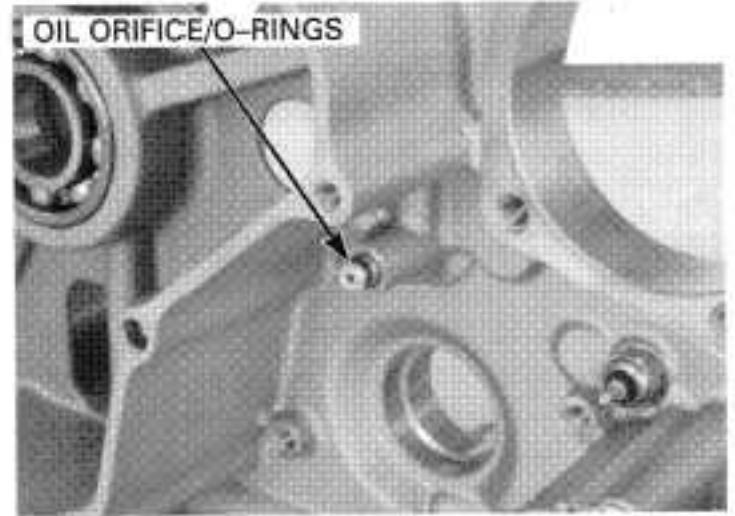

Coat a new O-ring with engine oil and install it into the groove in the bearing holder. Be sure to install the dowel pin in the bearing holder and install the output gear assembly onto the left crankcase.

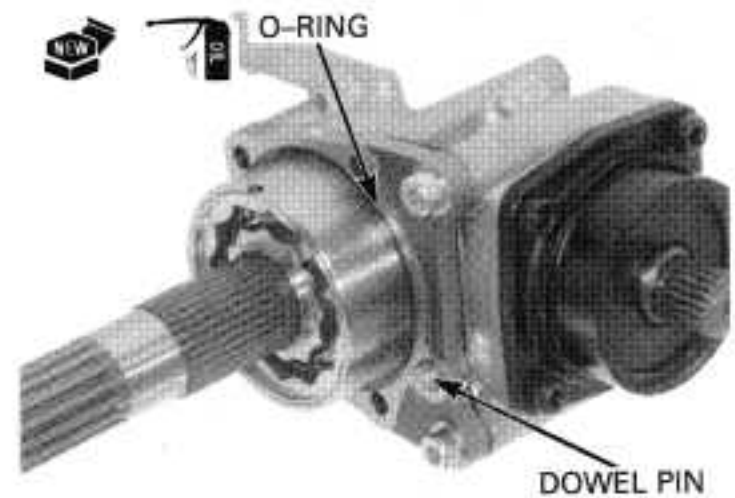

Install and tighten the gear case mounting bolts to the specified torque.

**TORQUE: 31 N·m (3.2 kgf·m, 23 lbf·ft)**

Install the transmission (page 11-16).  
Assemble the crankcase (page 11-17).

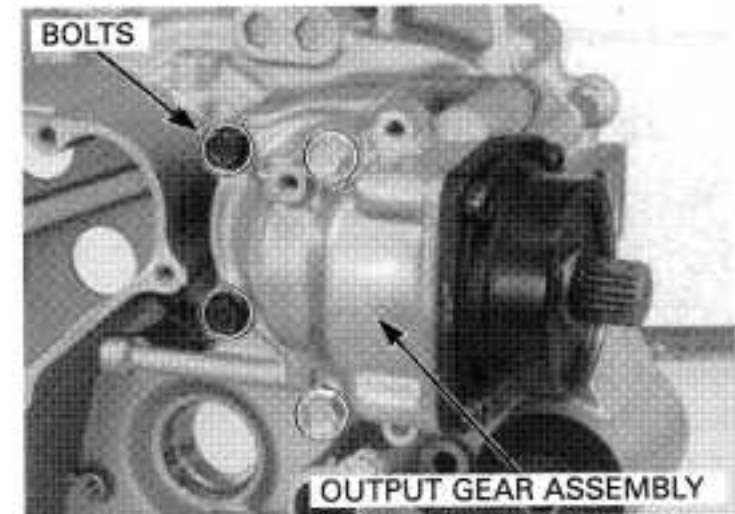

## CRANKCASE BEARING REPLACEMENT

### LEFT CRANKCASE BEARING

*Always wear insulated gloves when handling a heated gear case.*

Remove the output gear case assembly (page 11-19).

Before removing the bearings, heat the crankcase around the bearings to 80°C (176°F). Be careful not to damage the crankcase mating surfaces.

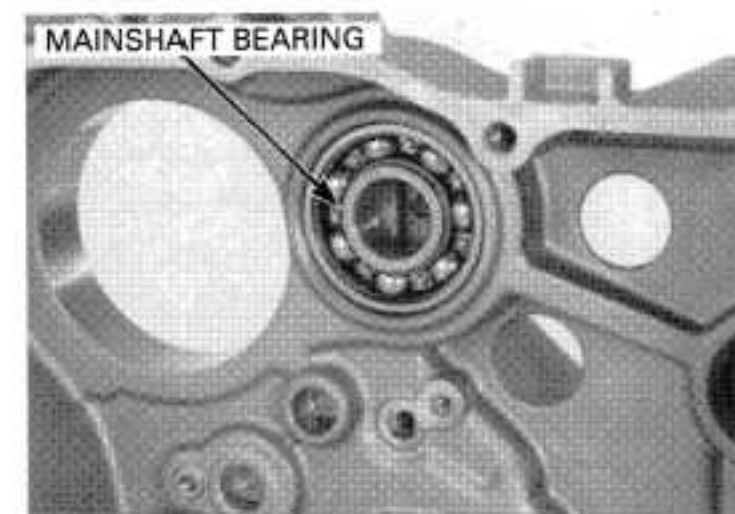

## CRANKSHAFT/TRANSMISSION

Remove the mainshaft bearing with the following special tools.

**TOOLS:**

Remover handle	07936-3710100
Bearing remover, 22 mm	07936-3710600
Remover shaft weight	07936-371020A or 07936-3710200

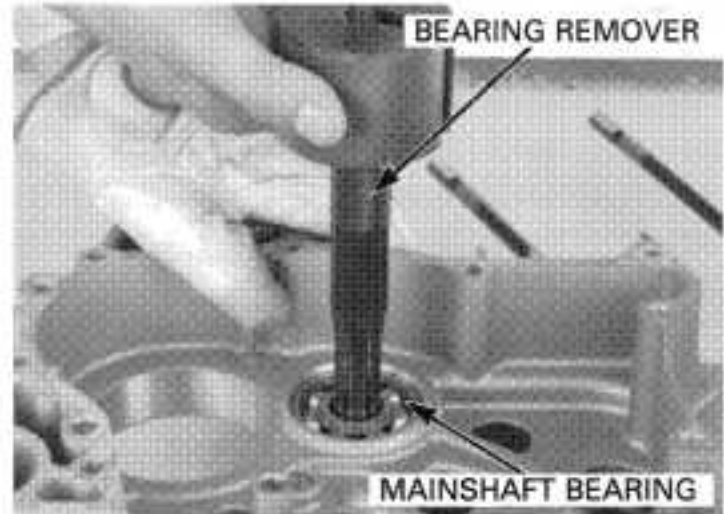

Drive the new mainshaft bearing into the left crankcase with its sealed side facing down using following special tools.

**TOOLS:**

Driver	07749-0010000
Attachment, 52 x 55 mm	07746-0010400
Pilot, 22 mm	07746-0041000

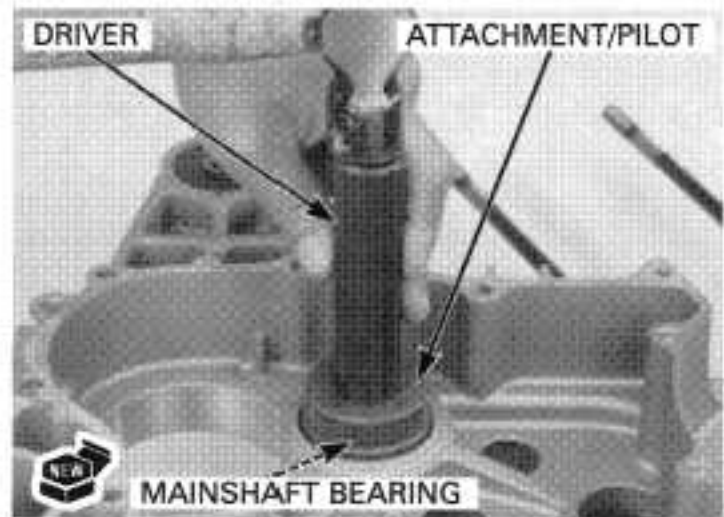

Drive the primary shaft bearing out of the right crankcase.

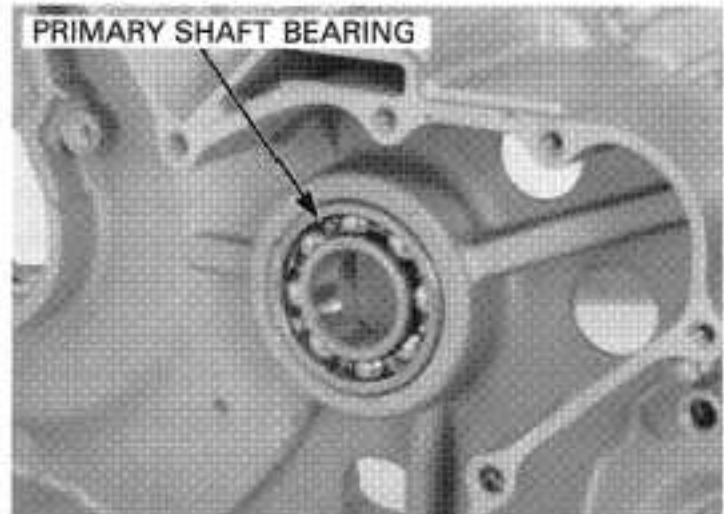

Drive the new primary shaft bearing into the left crankcase with the following special tools.

**TOOLS:**

Driver	07749-0010000
Attachment, 62 x 68 mm	07746-0010500
Pilot, 28 mm	07746-0041100

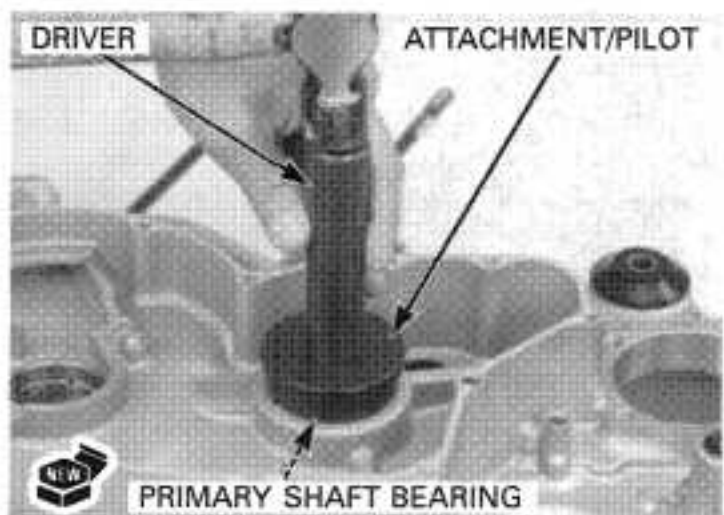



**RIGHT CRANKCASE BEARINGS**

Disassemble the crankcase (page 11-4).

Remove the bolts and bearing set plate from the right crankcase.

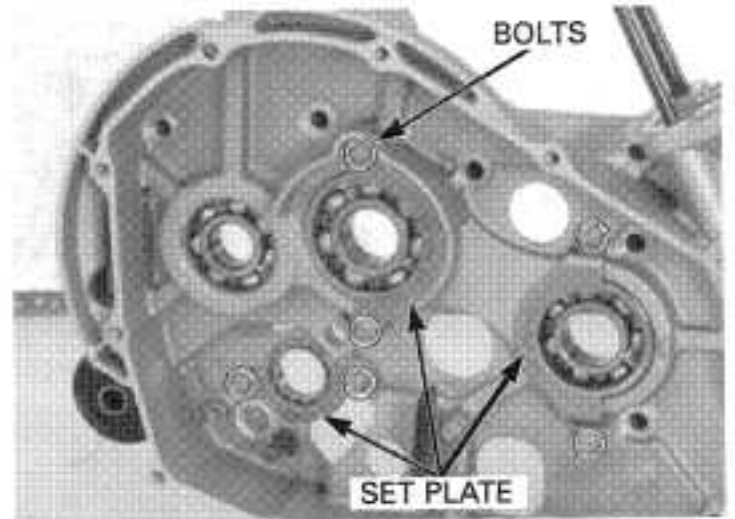

Drive the bearings out of the right crankcase.

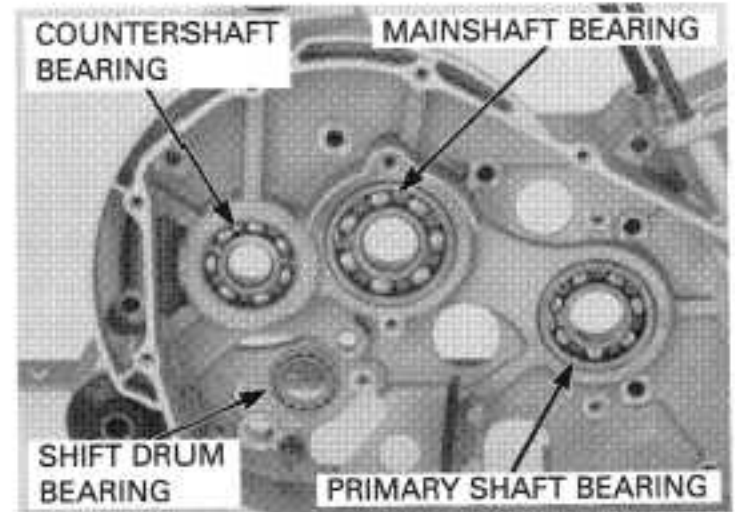

Drive the new mainshaft bearing into the right crankcase with the following special tools.

**TOOLS:**  
 Driver 07749-0010000  
 Attachment, 62 x 68 mm 07746-0010500  
 Pilot, 28 mm 07746-0041100

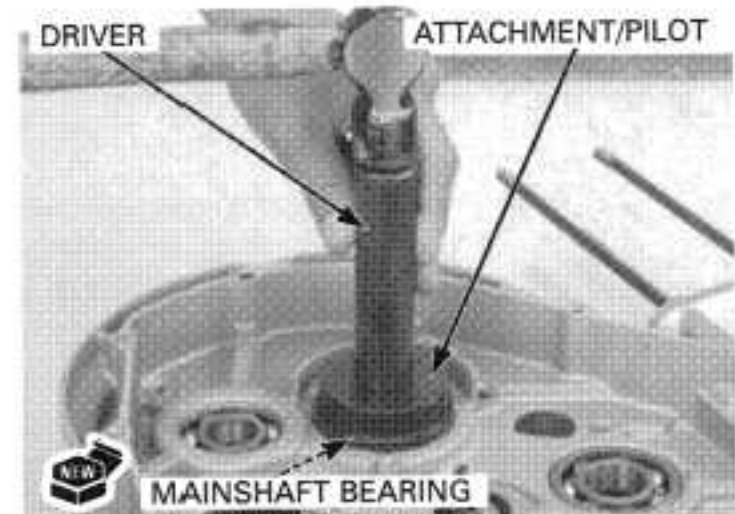

Drive the new countershaft bearing into the right crankcase with the following special tools.

**TOOLS:**  
 Driver 07749-0010000  
 Attachment, 52 x 55 mm 07746-0010400  
 Pilot, 22 mm 07746-0041000

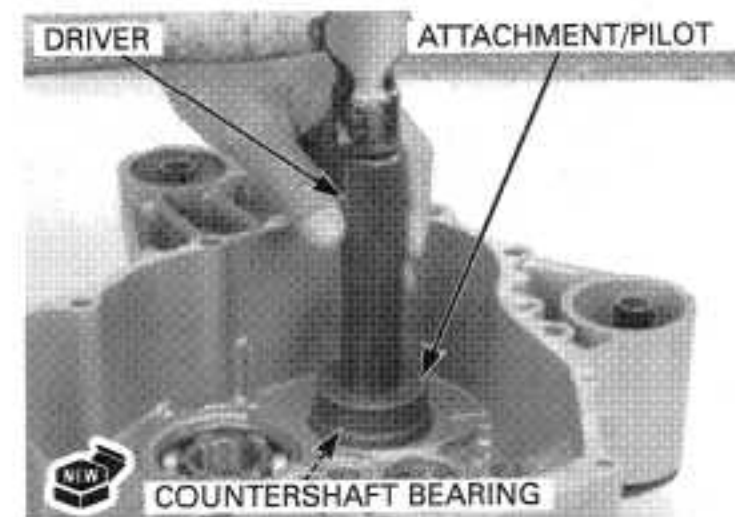



## CRANKSHAFT/TRANSMISSION

Drive the new shift drum bearing into the right crankcase with the following special tools.

**TOOLS:**

Driver	07749-0010000
Attachment, 32 x 35 mm	07746-0010100
Pilot, 25 mm	07746-0040600

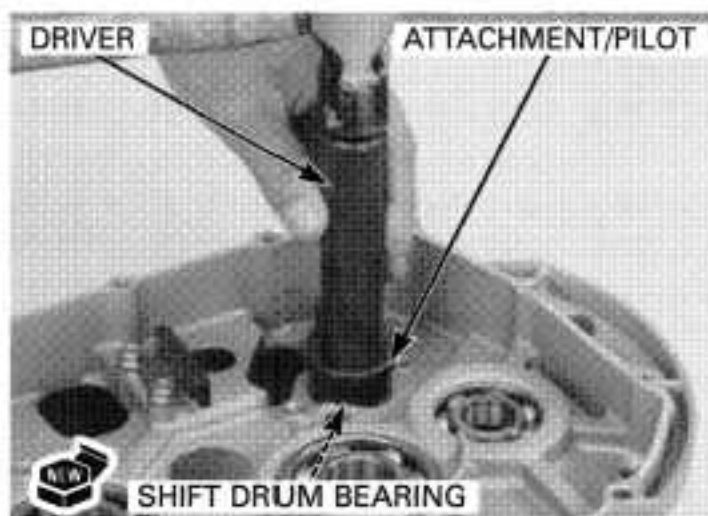

Drive the new primary shaft bearing into the right crankcase with the following special tools.

**TOOLS:**

Driver	07749-0010000
Attachment, 62 x 68 mm	07746-0010500
Pilot, 28 mm	07746-0041100

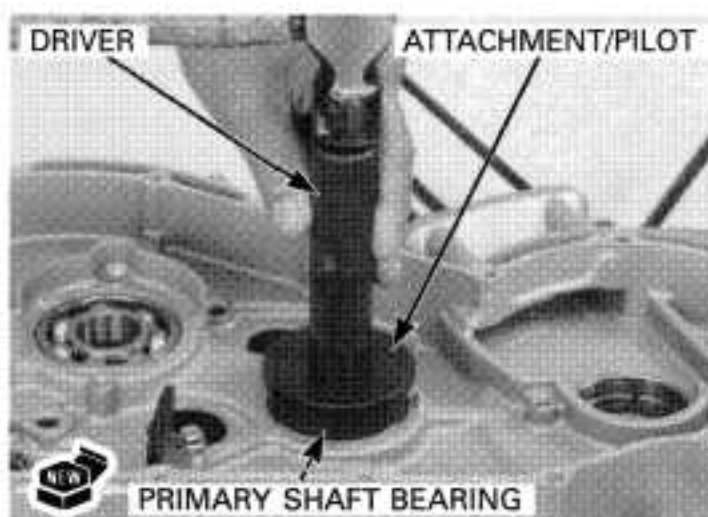

After installing the bearings, apply locking agent to the threads of the setting plate bolts. Install the setting plate and tighten the setting plate bolts securely.

Assemble the crankcase (page 11-17).

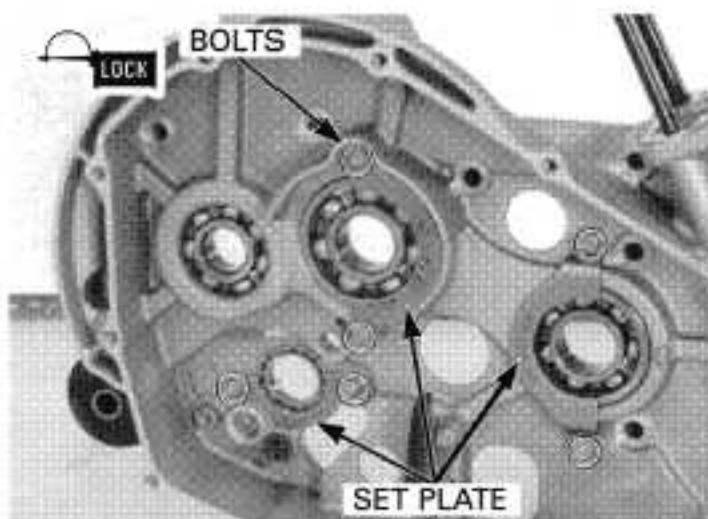

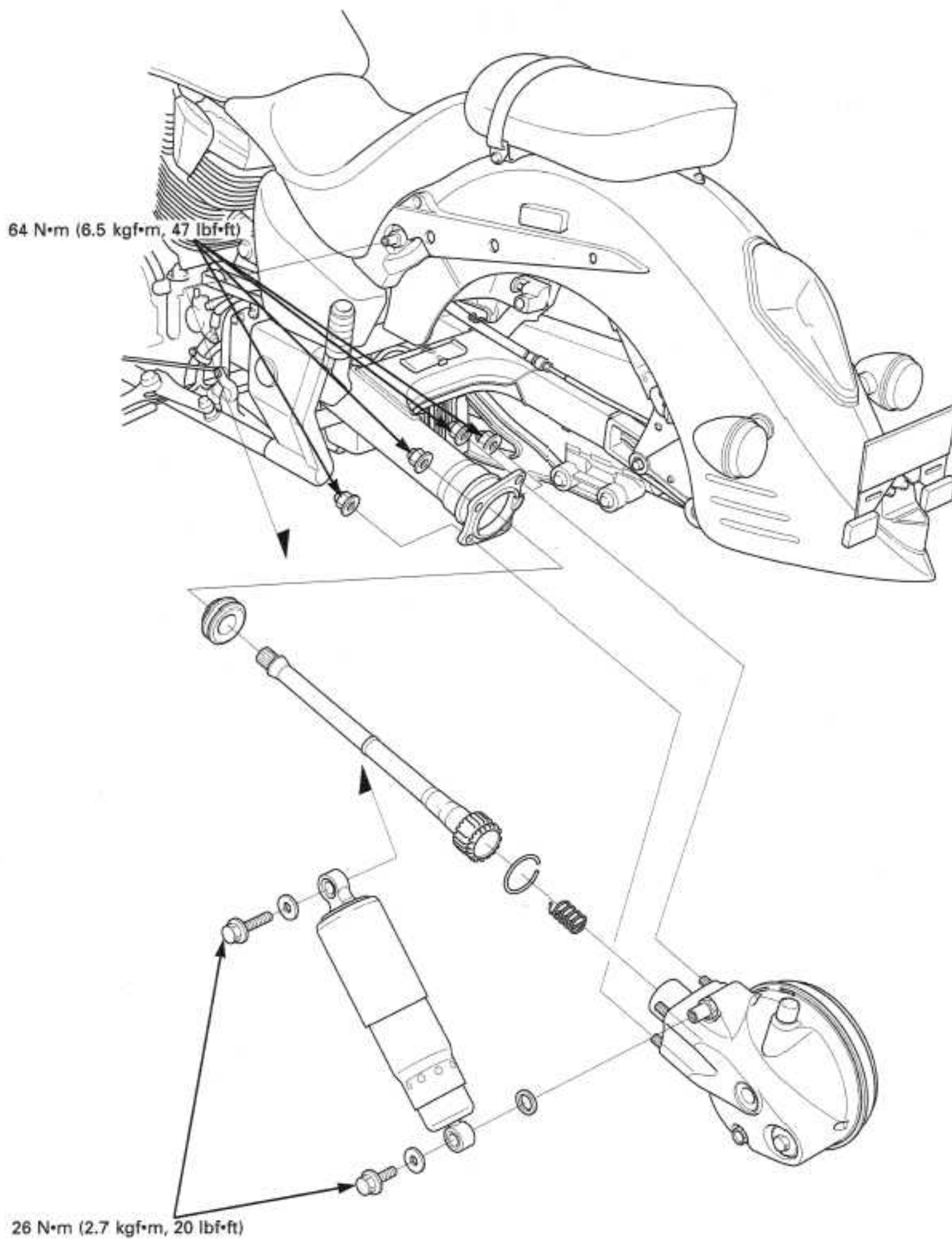

# 12. FINAL DRIVE

<b>SERVICE INFORMATION</b>	<b>12-1</b>	<b>FINAL DRIVE GEAR</b>	<b>12-5</b>
<b>TROUBLESHOOTING</b>	<b>12-2</b>	<b>FINAL DRIVE INSTALLATION</b>	<b>12-18</b>
<b>FINAL DRIVE REMOVAL</b>	<b>12-3</b>		

## SERVICE INFORMATION

### GENERAL

- The final drive gear assembly and final drive shaft must be removed together.
- Replace the ring and pinion gears as a set.
- Perform the gear contact pattern and backlash inspection whenever you replace the bearings, gears or gear case. The extension lines from the gear engagement surfaces should intersect at one point.
- Protect the gear case with a shop towel or soft jaws while holding it in a vise. Do not clamp the gear case too tightly or it could be damaged.

### SPECIFICATION

Unit: mm (in)

ITEM		STANDARD	SERVICE LIMIT
Recommended final drive oil		Hypoid gear oil, SAE #80	—
Final drive oil capacity	at disassembly	150 cm <sup>3</sup> (5.1 US oz, 5.3 Imp oz)	—
	at draining	120 cm <sup>3</sup> (4.1 US oz, 4.2 Imp oz)	—
Final drive gear backlash		0.05 – 0.15 (0.002 – 0.006)	0.30 (0.012)
Backlash difference between measurement		—	0.10 (0.004)
Ring gear-to-stop pin clearance		0.30 – 0.60 (0.012 – 0.024)	—
Final drive gear assembly preload		0.2 – 0.4 N•m (2 – 4 kgf•cm, 1.7 – 3.5 lbf•ft)	—

12

### TORQUE VALUES

Final gear case mounting nut	64 N•m (6.5 kgf•m, 47 lbf•ft)
Final drive oil filler cap	12 N•m (1.2 kgf•m, 9 lbf•ft)
Final drive oil drain bolt	20 N•m (2.0 kgf•m, 14 lbf•ft)
Gear case cover bolt (10 mm)	62 N•m (6.3 kgf•m, 46 lbf•ft) Apply a locking agent to the threads.
Gear case cover bolt (8 mm)	25 N•m (2.6 kgf•m, 19 lbf•ft)
Pinion retainer	147 N•m (15.0 kgf•m, 108 lbf•ft)
Pinion joint nut	108 N•m (11.0 kgf•m, 80 lbf•ft) Apply a locking agent to the threads.
Pinion retainer lock tab bolt	10 N•m (1.0 kgf•m, 7 lbf•ft)
Dust guard plate bolt	10 N•m (1.0 kgf•m, 7 lbf•ft)

## FINAL DRIVE

---

### TOOLS

Attachment, 52 x 55 mm	07746-0010400
Attachment, 72 x 75 mm	07746-0010600
Driver, 40 mm I.D.	07746-0030100
Attachment, 30 mm I.D.	07746-0030300
Pilot, 35 mm	07746-0040800
Driver	07749-0010000
Retainer wrench	07910-4630100
Pinion holder plate	07924-ME40010
Collar set "C"	07924-ME40020
Puller shaft	07931-ME4010B
Special nut	07931-HB3020A
Remover handle	07936-3710100
Remover weight	07936-371020A or 07936-3710200
Bearing remover	07936-3710300
Driver handle attachment	07949-3710001
Bearing puller driver attachment	07965-MB00100
Oil seal driver	07965-MC70100
Bearing driver attachment	07GMD-SD40101
Puller base	07HMC-MM8011A
Case puller	07SMC-0010001

### TROUBLESHOOTING

#### Excessive noise

- Worn or scored ring gear shaft and driven flange
- Scored driven flange and wheel hub
- Worn or scored drive pinion and splines
- Worn pinion and ring gears
- Excessive backlash between pinion and ring gear
- Oil level too low

#### Oil leak

- Clogged breather
- Oil level too high
- Seals damaged

## FINAL DRIVE REMOVAL

### REMOVAL

Drain the final drive oil (page 3-17).  
Remove the rear wheel (page 14-3).

Support the swingarm and remove the left shock absorber lower mounting bolt and release the shock absorber from the gear case.  
Remove the gear case mounting nuts, then remove the final gear case.

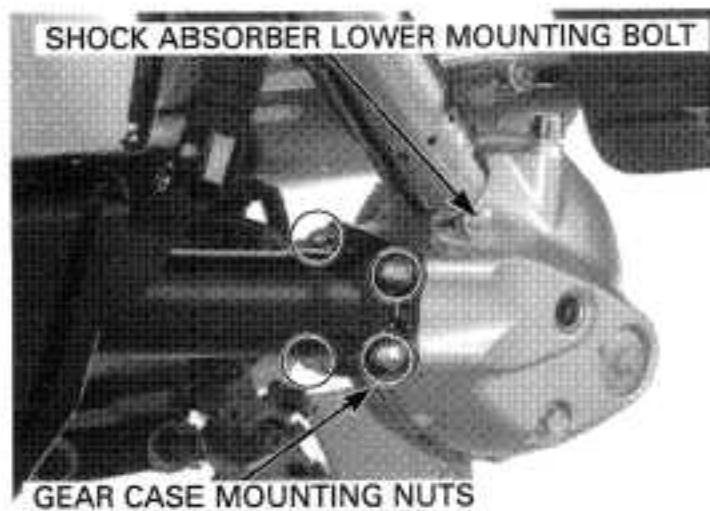

### DRIVE SHAFT REMOVAL/DISASSEMBLY

Separate the drive shaft from the gear case by gently turning the drive gear shaft and pulling.

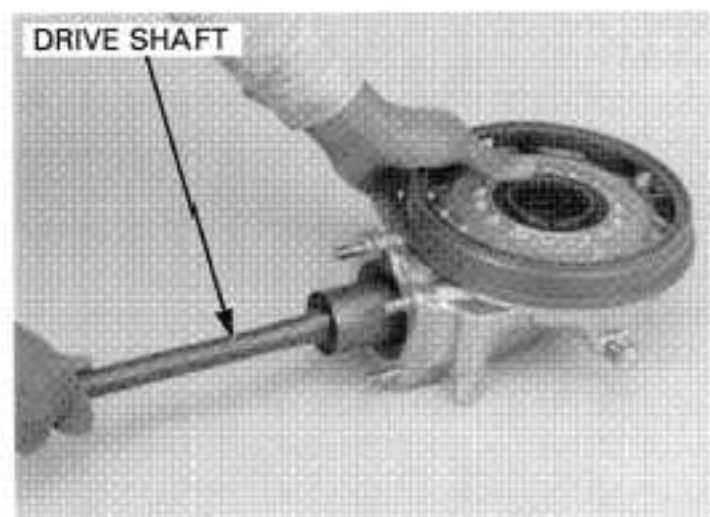

Remove the spring, oil seal and stopper ring from the drive shaft.

Check the splines of the drive shaft for damage or wear.  
If the splines of the drive shaft are damaged, check the universal joint splines also.



### UNIVERSAL JOINT REMOVAL

Remove the swingarm (page 14-12) and remove the universal joint from the swingarm.

Check that the universal joint moves smoothly without binding or noise.  
Check the splines for wear or damage.

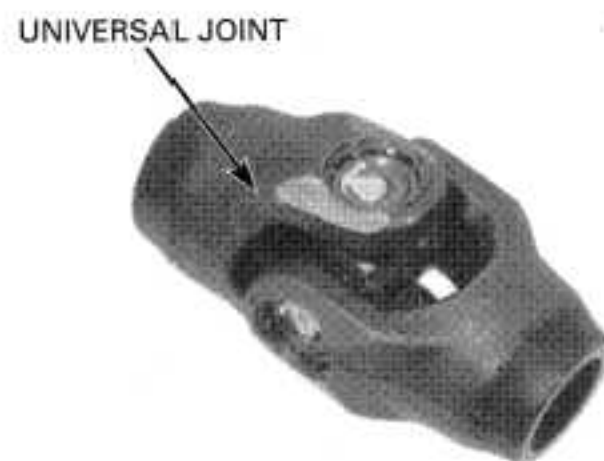



### FINAL DRIVE INSPECTION

Turn the pinion joint and check that the ring gear turns smoothly and quietly without binding.

If the gears do not turn smoothly or quietly, the bearings and/or gears may be damaged or faulty. They must be checked after disassembly; replace them if necessary.

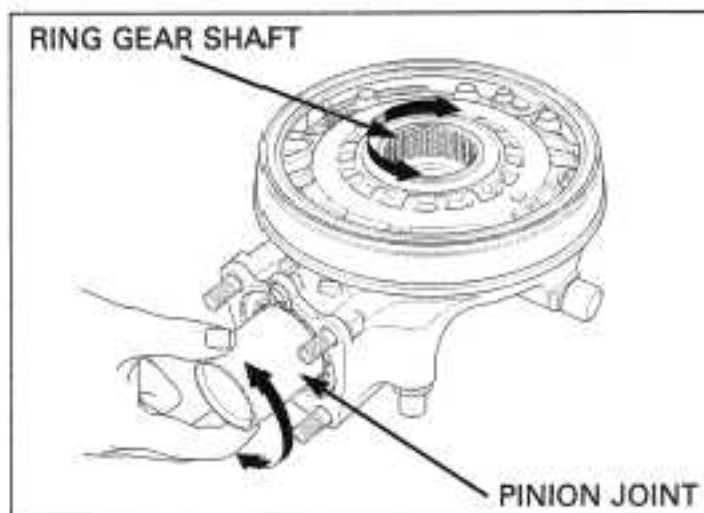

### BACKLASH INSPECTION

- Perform the backlash inspection and tooth contact pattern check (page 12-10) whenever you replace the gear set, bearings or gear case. The extension lines from the gear engagement surfaces should intersect at one point.

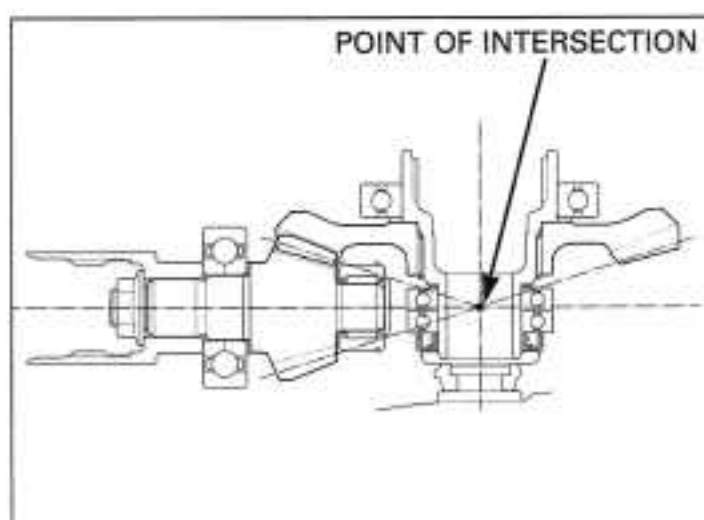

Remove the oil filler cap.  
Place the final gear assembly into a jig or vise with soft jaws.

Set a horizontal type dial indicator on the ring gear, through the oil filler hole.  
Hold the pinion gear spline with the pinion holder plate and collars.

**TOOLS:**  
**Pinion holder plate**                      07924-ME40010  
**Collar set "C"**                         07924-ME40020

Turn the ring gear back and forth to read the backlash.

**STANDARD:**    0.05 – 0.15 mm (0.002 – 0.006 in)  
**SERVICE LIMIT:** 0.30 mm (0.012 in)

Remove the dial indicator. Turn the ring gear 120° and measure the backlash. Repeat this procedure once more.

Compare the difference between the three measurements.

**Backlash difference between measurements:**  
**SERVICE LIMIT:** 0.10 mm (0.004 in)

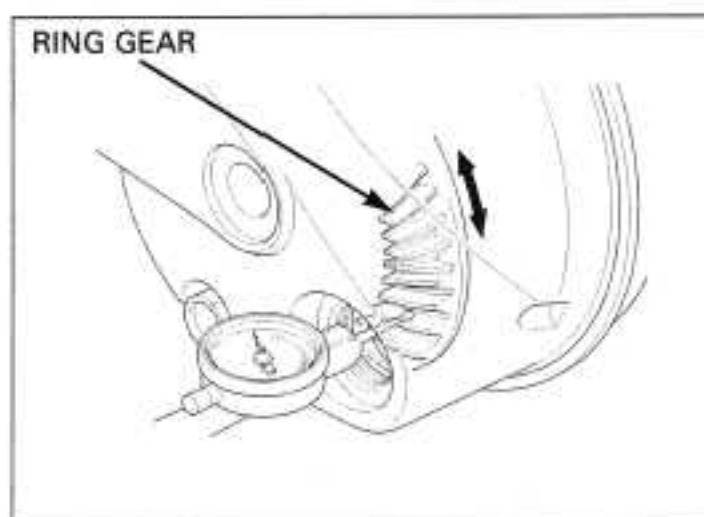
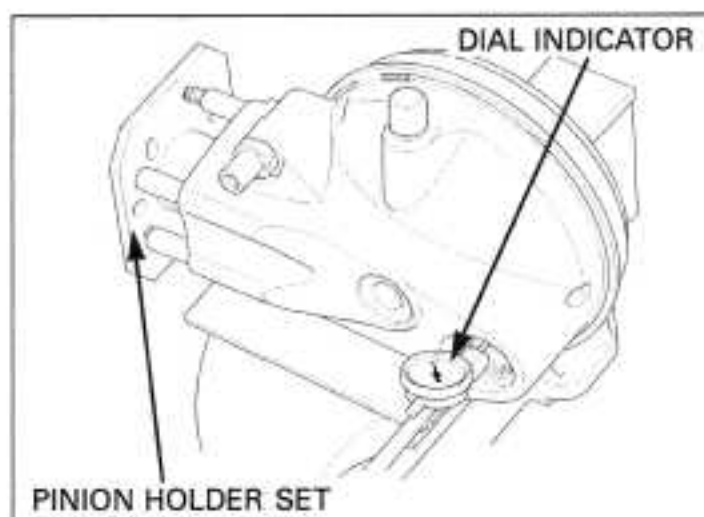

If the difference in measurements exceeds the limit, it indicates that the bearing is not installed squarely. Inspect the bearings and install if necessary.

If backlash is excessive, replace the ring gear shim with a thicker one.

If the backlash is too small, replace the ring gear shim with a thinner one.

**Ring gear shims:**

A: 1.82 mm (0.072 in)    G: 2.18 mm (0.086 in)  
B: 1.88 mm (0.074 in)    H: 2.24 mm (0.088 in)  
C: 1.94 mm (0.076 in)    I: 2.30 mm (0.091 in)  
D: 2.00 mm (0.079 in) — Standard  
E: 2.06 mm (0.081 in)  
F: 2.12 mm (0.083 in)

## FINAL DRIVE GEAR

### RING GEAR REMOVAL/SHIM REPLACEMENT

Remove the distance collar.

Remove the dust guard plate bolt and remove the dust guard plate by turning it counterclockwise.

*Remove the wave washer if it remains in the gear case.*

Remove the case cover bolts and gear case cover.

If the ring gear stays in the cover, perform the following procedure.

Support the cover horizontally with the ring gear facing down and press the gear out using the special tools and hydraulic press.

**TOOLS:**

**Oil seal driver**

**07965-MC70100**

**Attachment, 72 x 75 mm**

**07746-0010600**

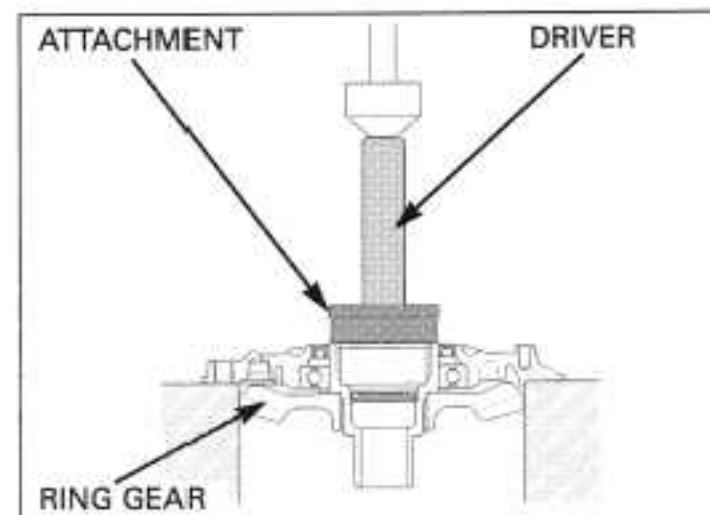
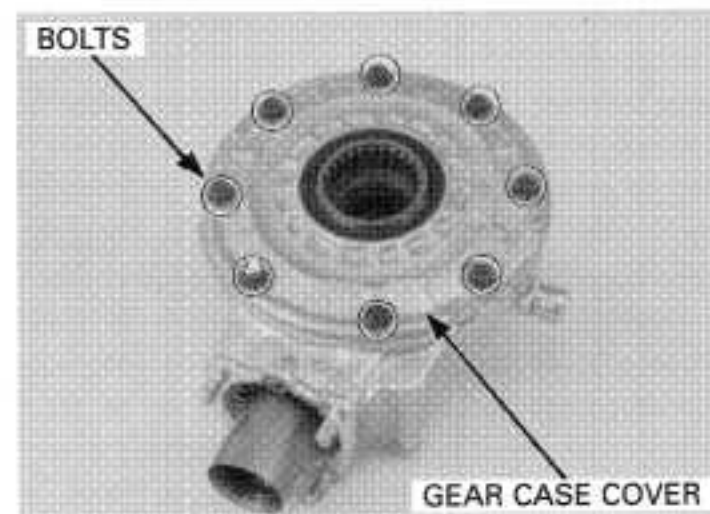
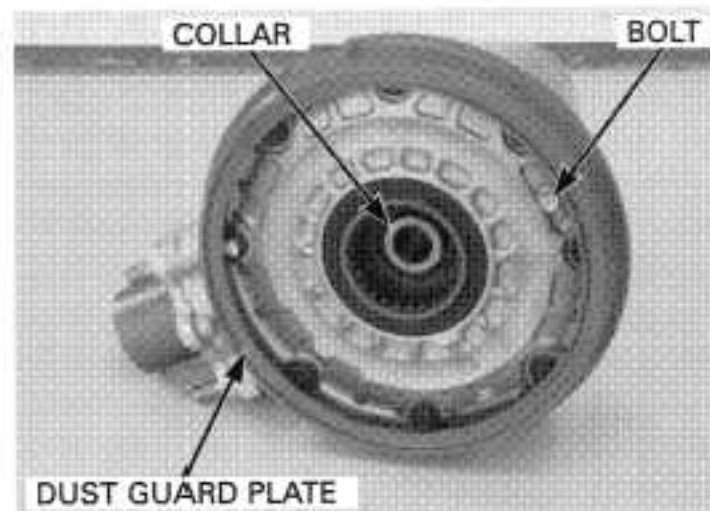
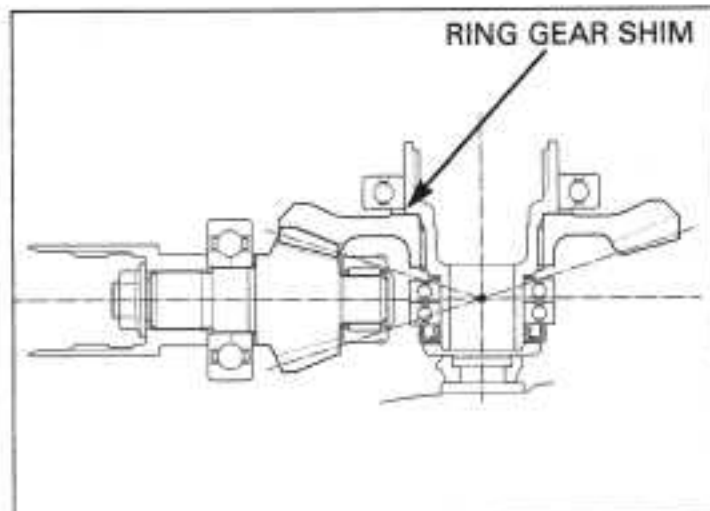

## FINAL DRIVE

Remove the ring gear from the gear case.

Remove the oil seal from the ring gear.

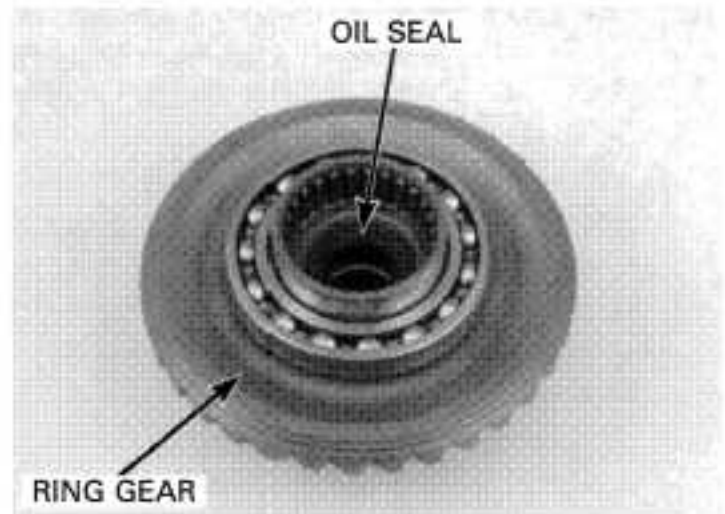

*This bearing may not need to be replaced after removal. However, inspect the bearing for excessive play after removal.*

Remove the ring gear bearing using the commercially available bearing puller.

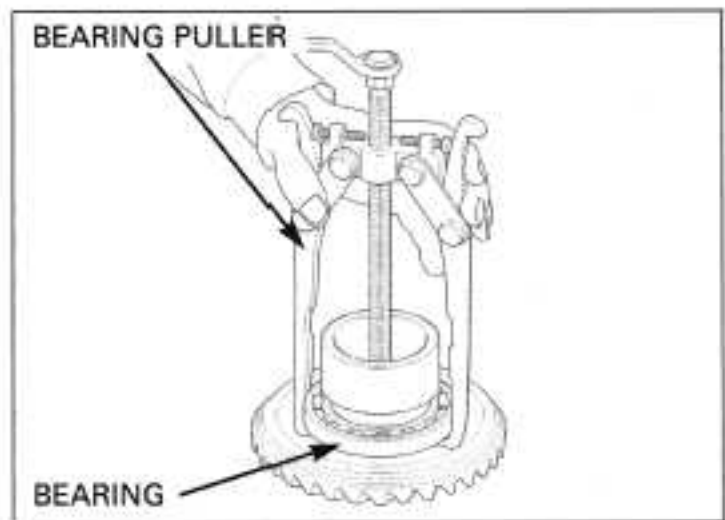

*If the gear set, pinion bearing, ring gear bearing and/or gear case are replaced, install a 2.00 mm (0.079 in) thick shim (standard).*

Replace the ring gear shim.

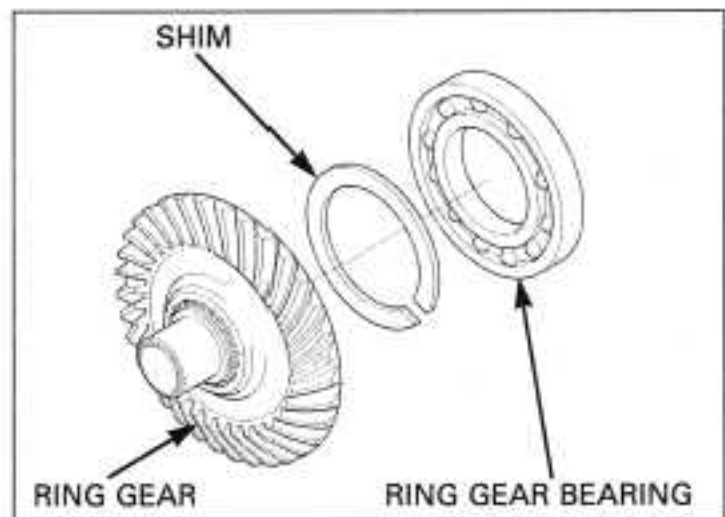

## RING GEAR INSTALLATION

For the case bearing replacement and breather hole cleaning, see page 12-17.

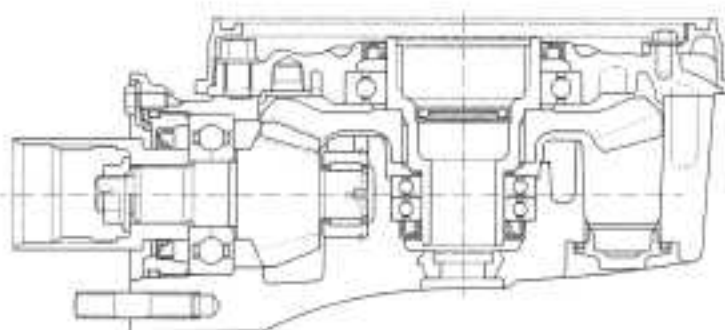
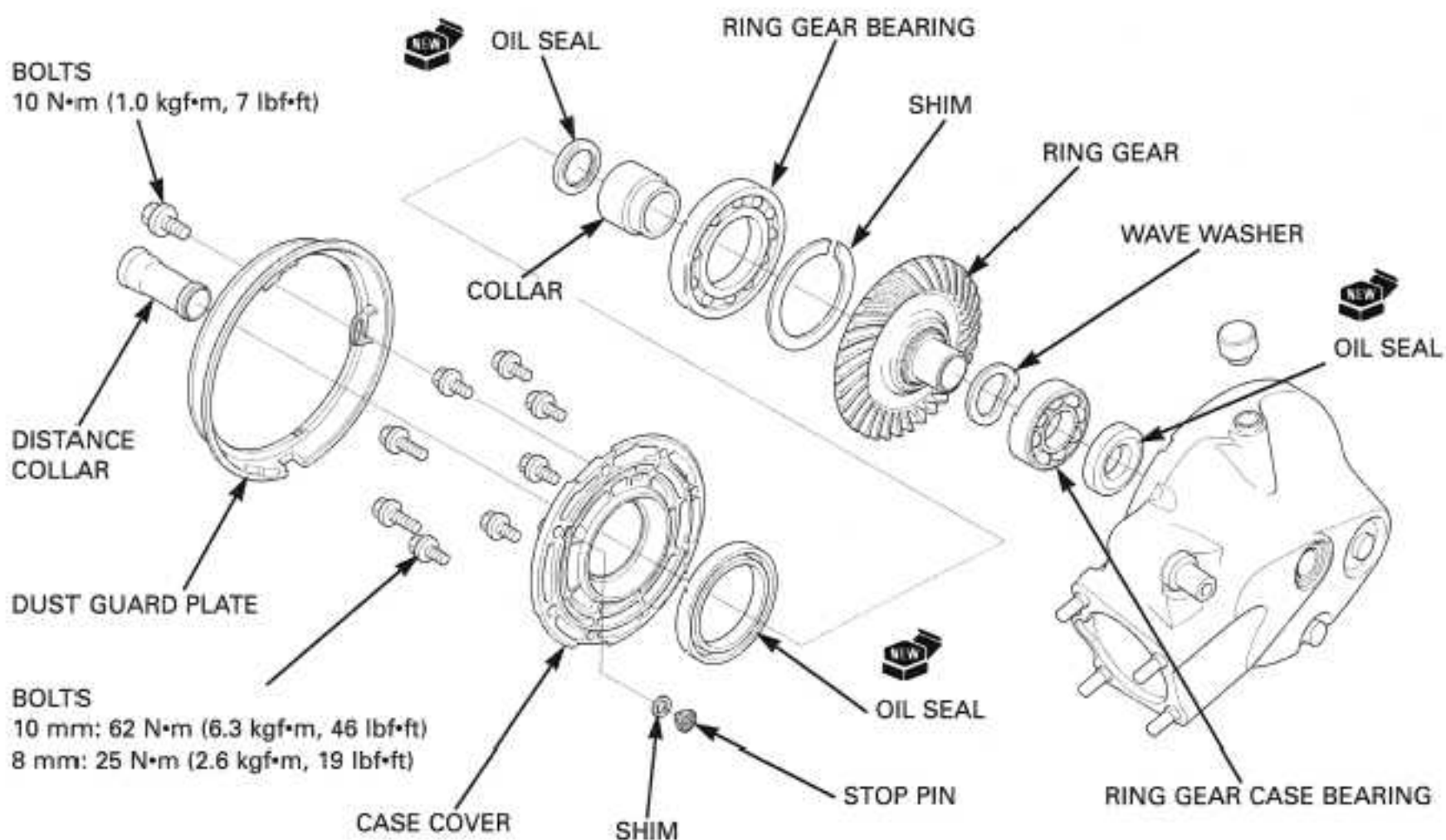

If the ring gear assembly was loose against the cover (if it did not stay in the cover), do the following:

Place the ring gear shim onto the ring gear (page 12-6).

Press the bearing onto the shaft.

**TOOLS:**

Oil seal driver

07965-MC70100

Attachment, 72 x 75 mm

07746-0010600

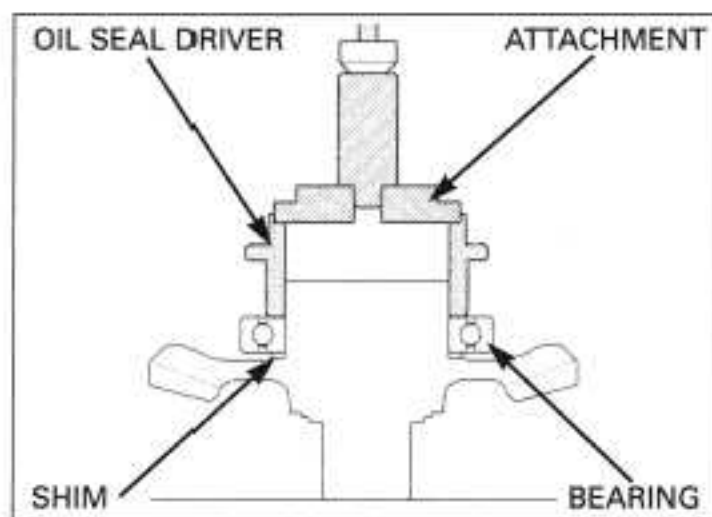

## FINAL DRIVE

If the ring gear remained in the cover, do the following:

Remove the case cover oil seal (see following page). Press the ring gear bearing into the cover using the special tools.

**TOOLS:**

**Driver** 07749-0010000  
**Bearing driver attachment** 07GAD-SD40101

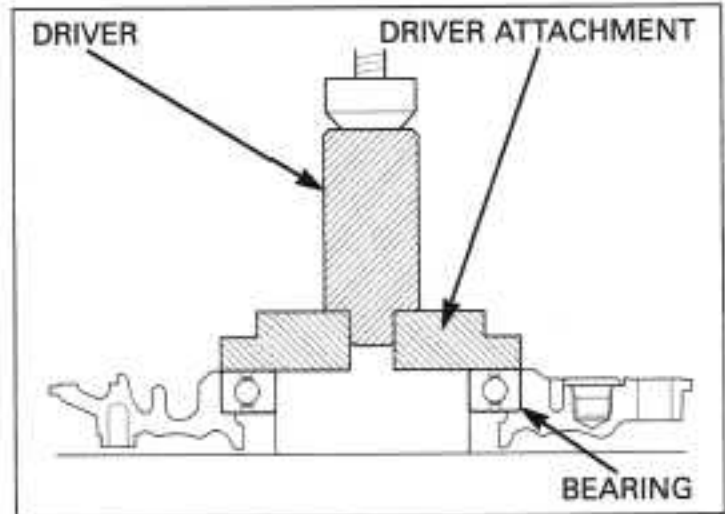

Install the shim onto the ring gear (page 12-6).

Support the bearing inner race with the special tool, and press the ring gear into the bearing.

**TOOLS:**

**Oil seal driver** 07965-MC70100

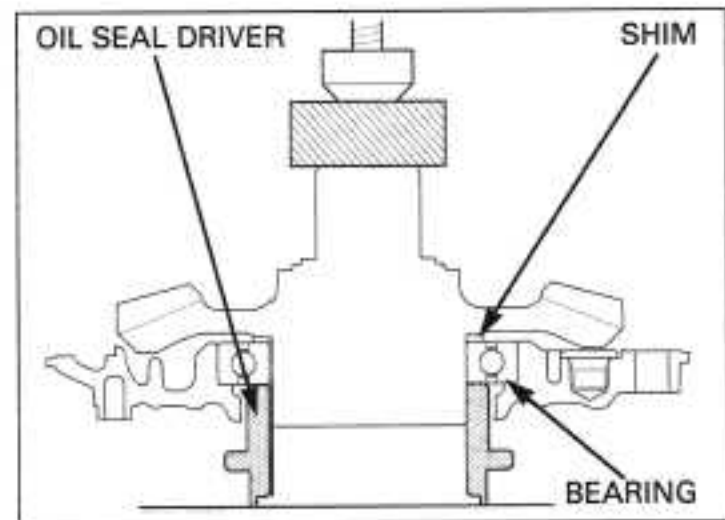

Coat a new oil seal with grease and install it into the ring gear.

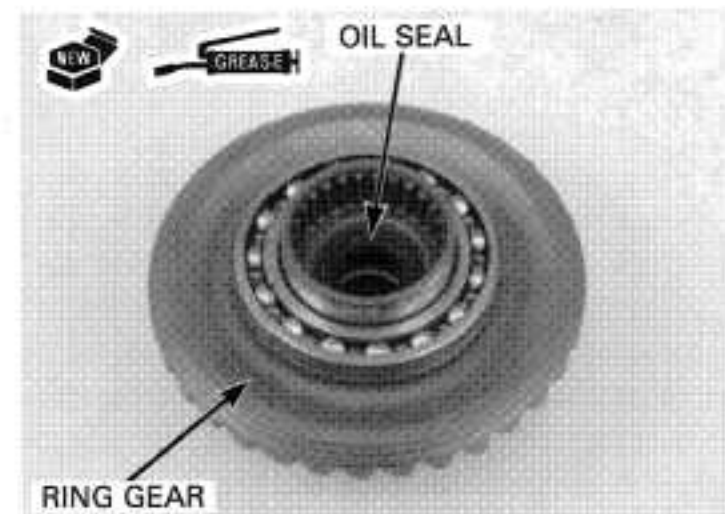

Remove and discard the case cover oil seal.

Install a new oil seal and apply grease to the seal lips.

**TOOLS:**

**Driver** 07749-0010000  
**Bearing driver attachment** 07GAD-SD40101

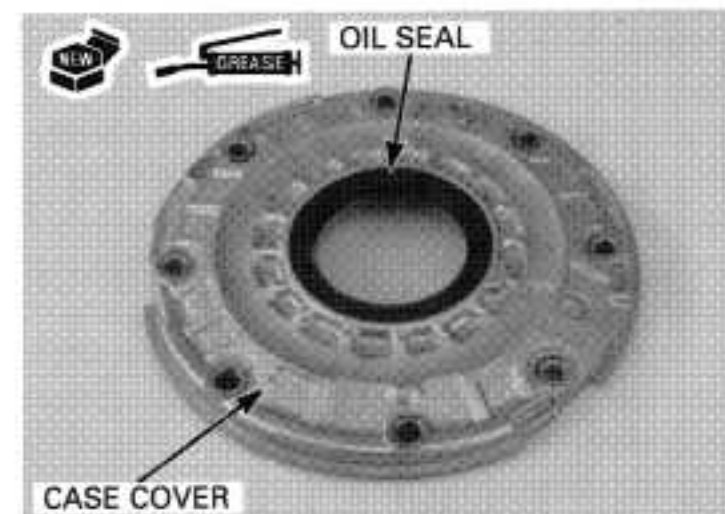



Install the ring gear into the gear case cover.

Measure the clearance between the ring gear and the ring gear stop pin with a feeler gauge.

**CLEARANCE: 0.30 – 0.60 mm (0.012 – 0.024 in)**

*Always wear insulated gloves when handling the heated gear case cover.*

Remove the ring gear if the clearance exceeds the service limit. Heat the gear case cover to approximately 80 °C (176 °F). Heat the case cover evenly and slowly to prevent warpage.

Do not heat small areas individually. When the gear cover case is heated to the proper temperature, remove the stop pin by tapping the cover.

**NOTICE**

*Case cover warpage can occur if the cover is not heated properly.*

Install a stop pin shim to obtain the correct clearance.

**SHIM THICKNESS: A: 0.10 mm (0.004 in)  
B: 0.15 mm (0.006 in)**

Install the shim and drive the stop pin into the case cover.

Clean all sealing material off the mating surfaces of the gear case and cover.

- Keep dust and dirt out of the gear case.
- Be careful not to damage the mating surfaces.

Check the gear tooth contact pattern after the ring gear shim has been replaced (see next page).

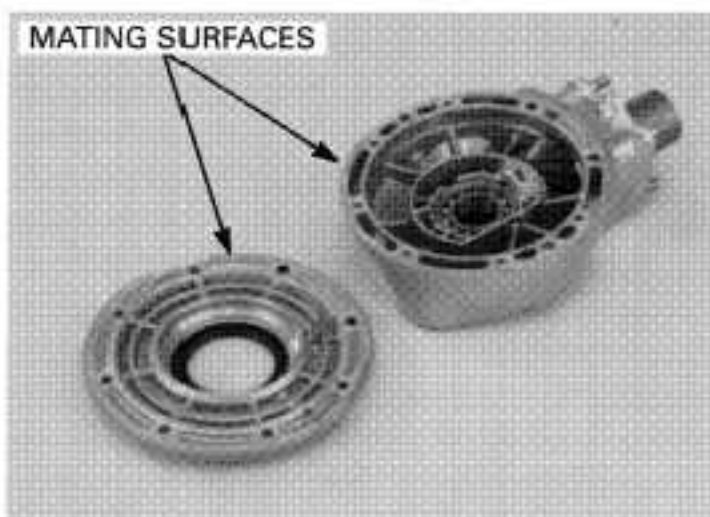
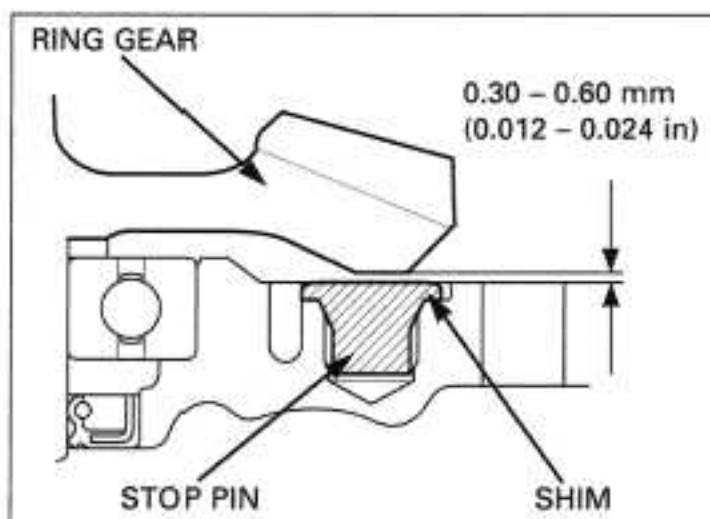
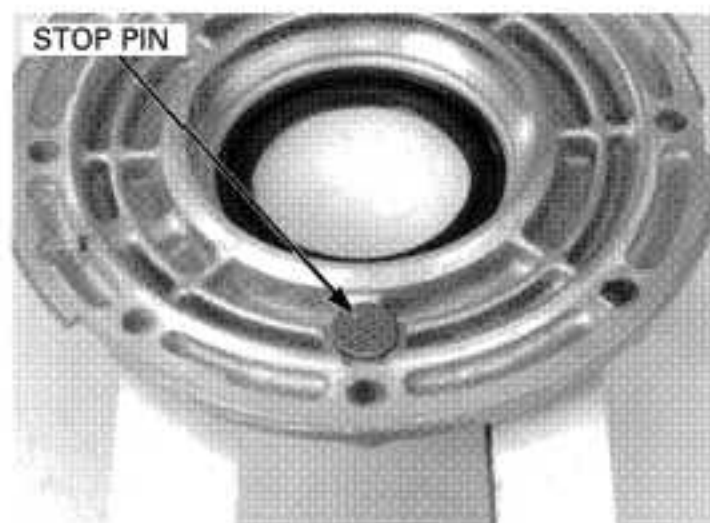
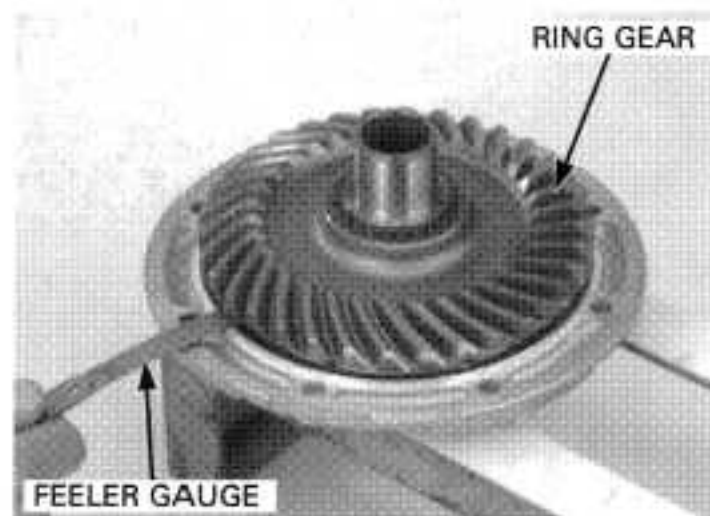

## GEAR TOOTH CONTACT PATTERN CHECK

Description of the tooth:

COAST SIDE

(contacts when engine brake is applied)

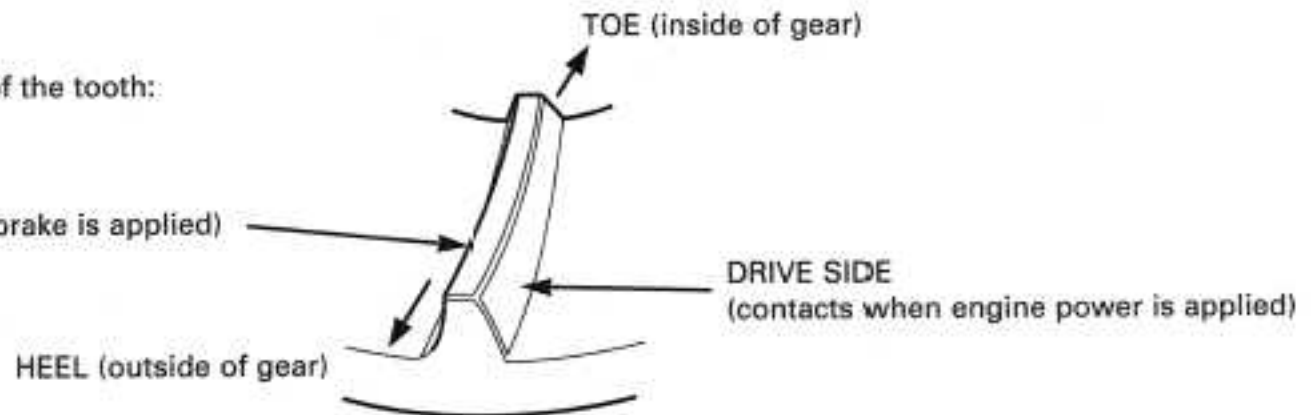

Apply a thin coat of Prussian Blue to the pinion gear teeth for a tooth contact pattern check.

Place the wave washer and ring gear into the gear case.

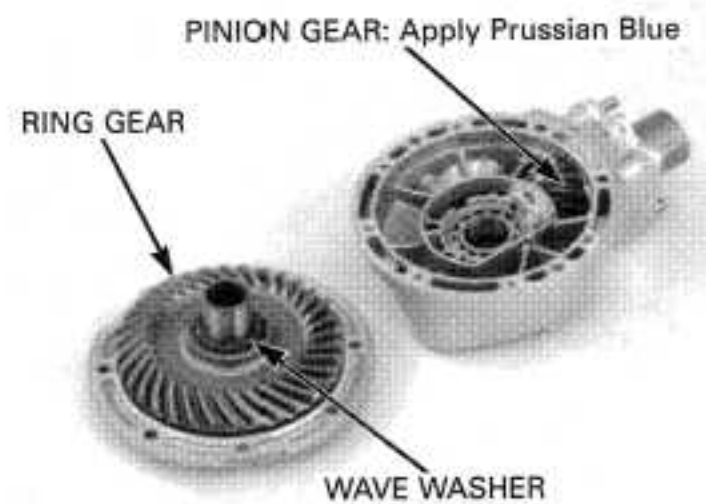

Pack grease into the seal lip cavity of the case cover oil seal and install the gear case cover.

Tighten the cover bolts in two or three steps until the cover evenly touches the gear case, then tighten the 8-mm bolts to the specified torque in a crisscross pattern in two or more steps.

Next tighten the 10-mm bolts to the specified torque.

**TORQUE: 8-mm: 25 N·m (2.6 kgf·m, 19 lbf·ft)**  
**10-mm: 62 N·m (6.3 kgf·m, 46 lbf·ft)**

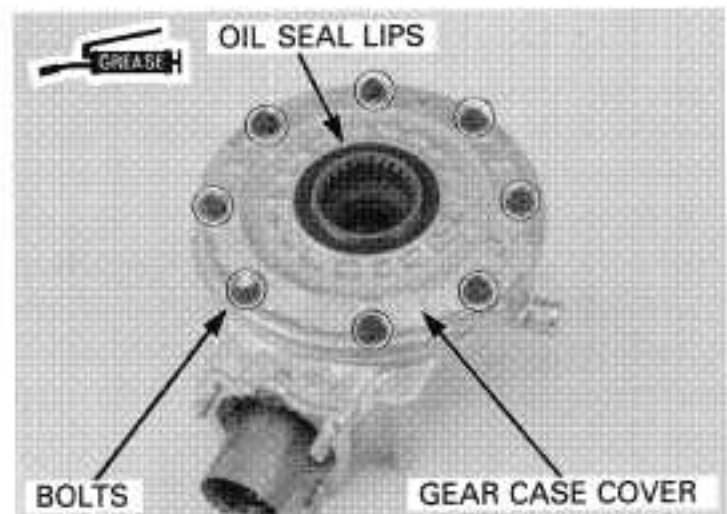

Remove the oil filler cap from the final gear case.

Rotate the ring gear several times in the normal direction of rotation.

Check the gear tooth contact pattern through the oil filler hole.

The pattern is indicated by the Prussian Blue applied to the pinion gear.

Contact is normal if the Prussian Blue is transferred to the approximate center of each tooth and slightly towards the face.

If the pattern is not correct, remove and change the pinion shim.

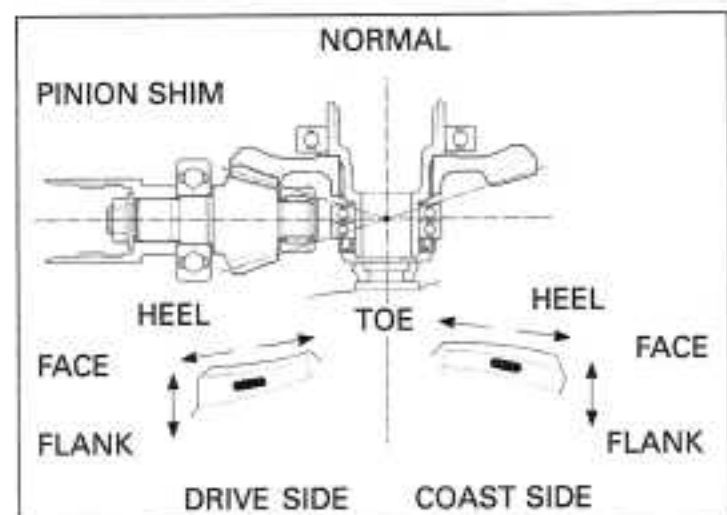

Replace the pinion shim with a thicker one if the contact pattern is too high.

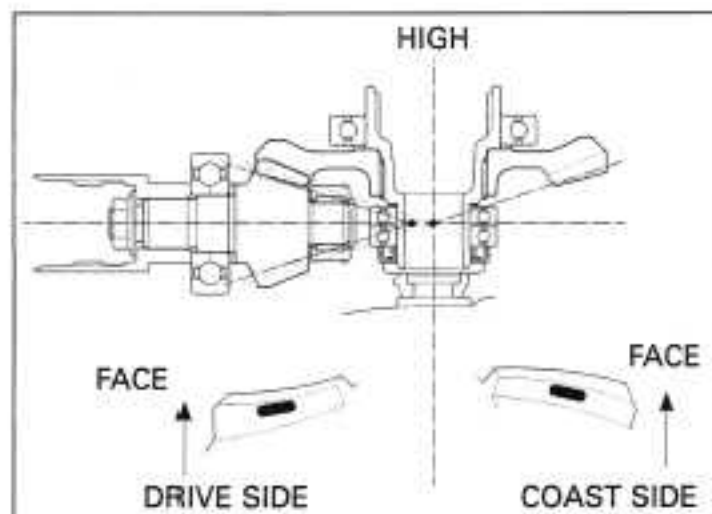

Replace the pinion shim with a thinner one if the contact pattern is too low.

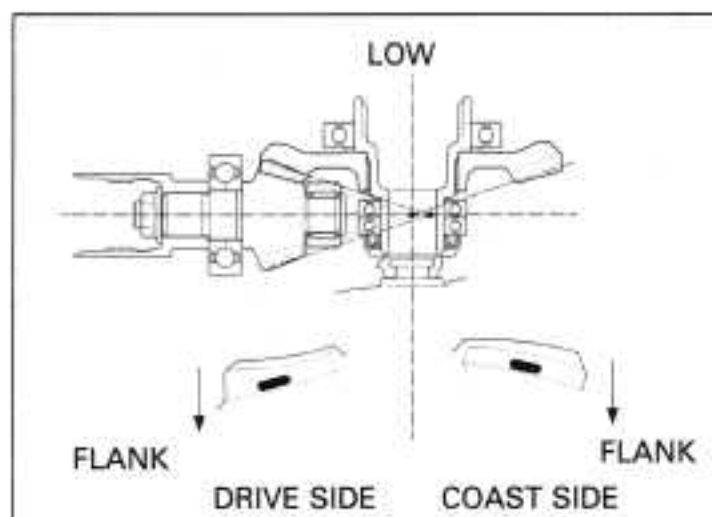

The patterns will shift about 1.5 – 2.0 mm (0.06 – 0.08 in) when the thickness of the shim is changed by 0.1 mm (0.004 in).

**Ring gear shims:**

- A: 1.82 mm (0.072 in)
- B: 1.88 mm (0.074 in)
- C: 1.94 mm (0.076 in)
- D: 2.00 mm (0.079 in) — Standard
- E: 2.06 mm (0.081 in)
- F: 2.12 mm (0.083 in)
- G: 2.18 mm (0.086 in)

For gear case assembly, see page 12-17.

**PINION GEAR REMOVAL/SHIM REPLACEMENT**

Place the final gear case in a vise with soft jaws.

Assemble the pinion holder plate and collars and install them onto the gear case to avoid damaging the gear case.

Remove the pinion joint nut.

**TOOLS:**

- Pinion holder plate 07924-ME40010
- Collar set "C" 07924-ME40020

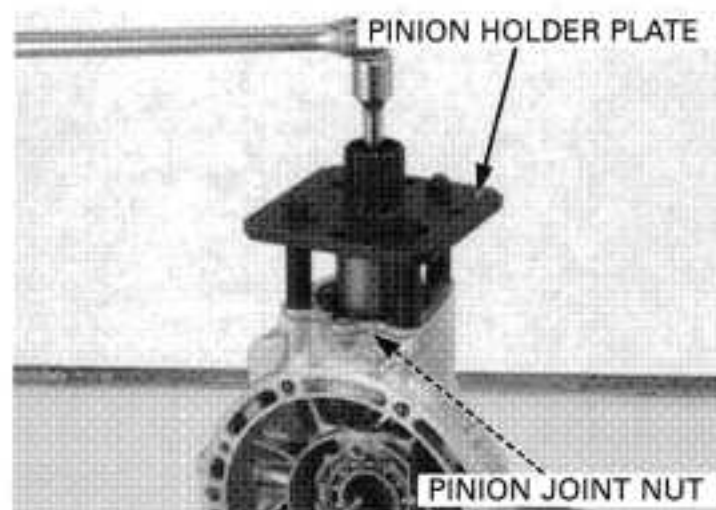

## FINAL DRIVE

Remove the bolt and retainer lock tab.

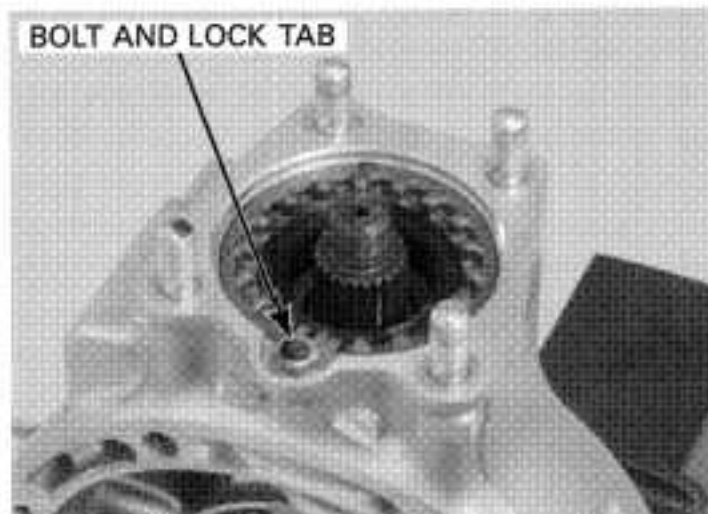

Remove the pinion retainer with the retainer wrench.

**TOOL:**

**Retainer wrench**

**07910-4630100**

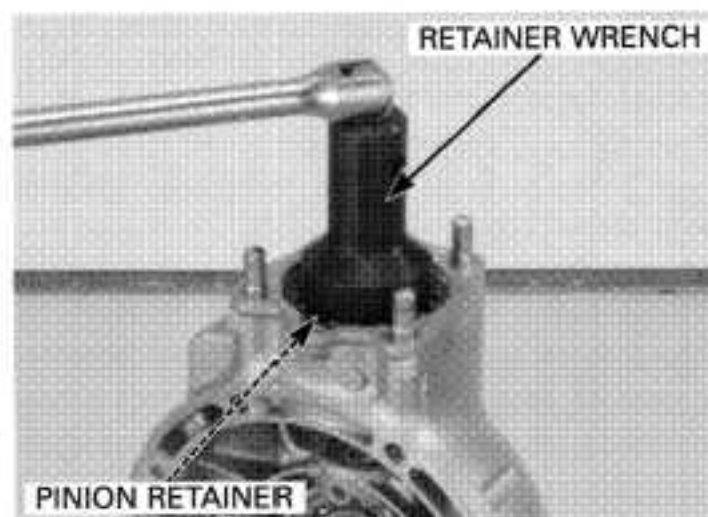

Assemble the pinion puller set as shown.  
Pull out the pinion assembly with the pinion puller.

**TOOLS:**

**Puller base**

**Puller shaft**

**Special nut**

**07HMC-MM8011A**  
**07931-ME4010B and**  
**07931-HB3020A**

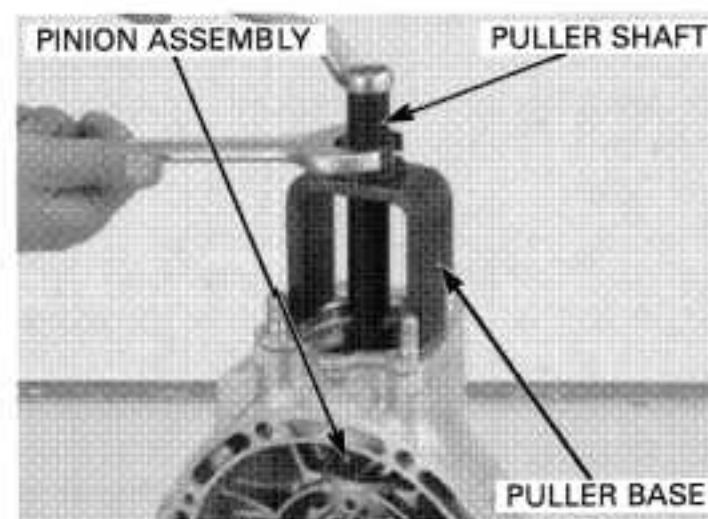

Pull the bearing outer and inner races from the shaft with the bearing puller.

This bearing may not need to be replaced after removal. However, inspect the bearing for excessive play after removal.

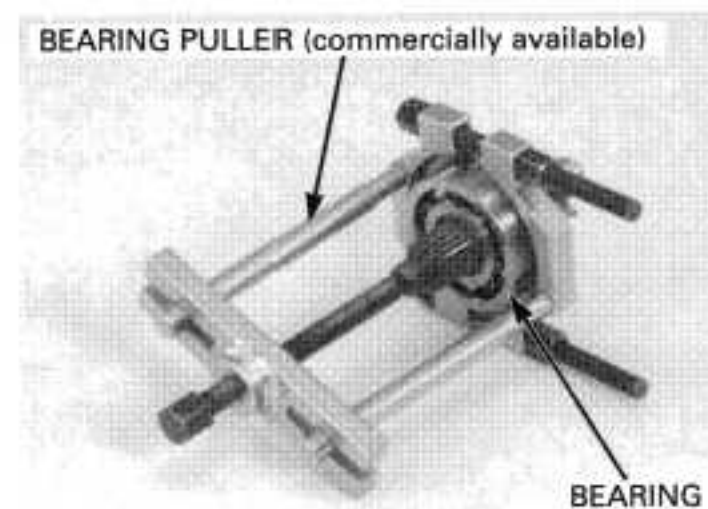



Remove the pinion shim.

If the gear set, pinion bearing, ring gear bearing and/or gear case are replaced, install a 2.00 mm (0.79 in) thick shim (standard) for initial reference.

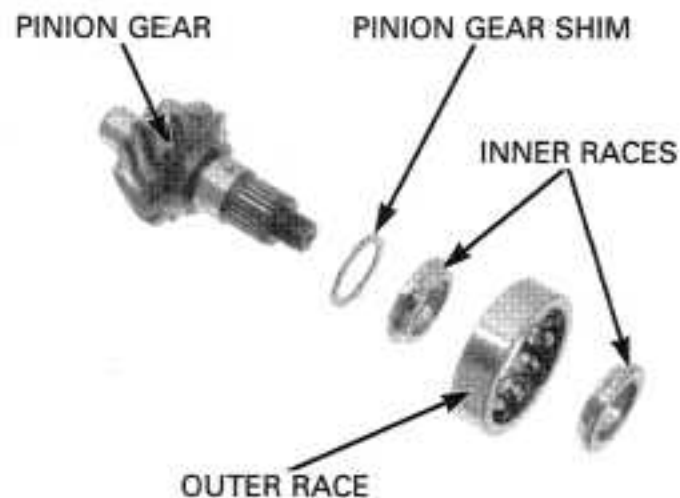

**PINION GEAR INSTALLATION**

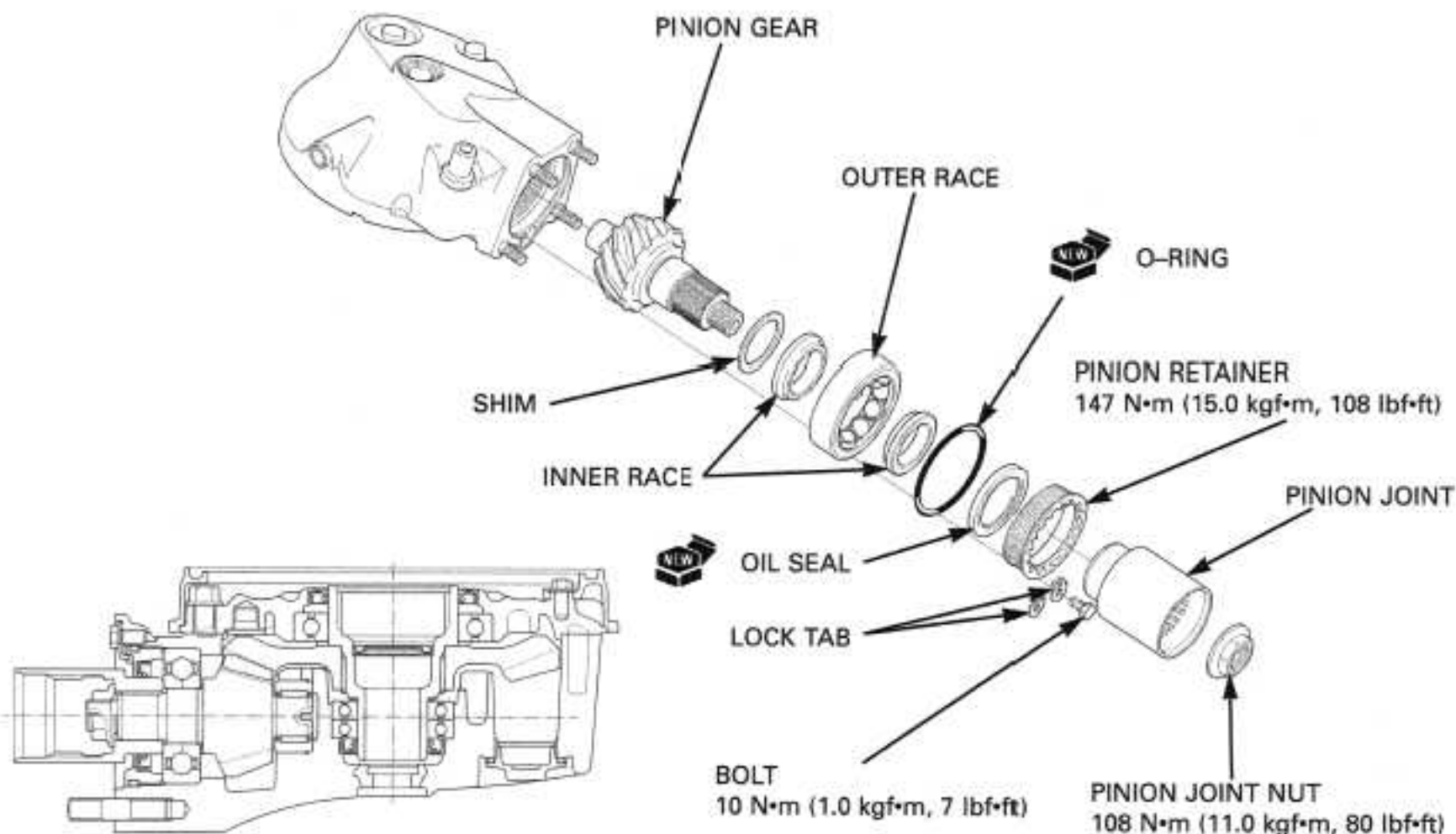

Install the pinion shim (see previous page) on the pinion gear.

Drive the pinion gear bearing onto the pinion gear using the special tool.

- TOOLS:**
- Driver, 40 mm I.D. 07746-0030100
  - Attachment, 30 mm I.D. 07746-0030300

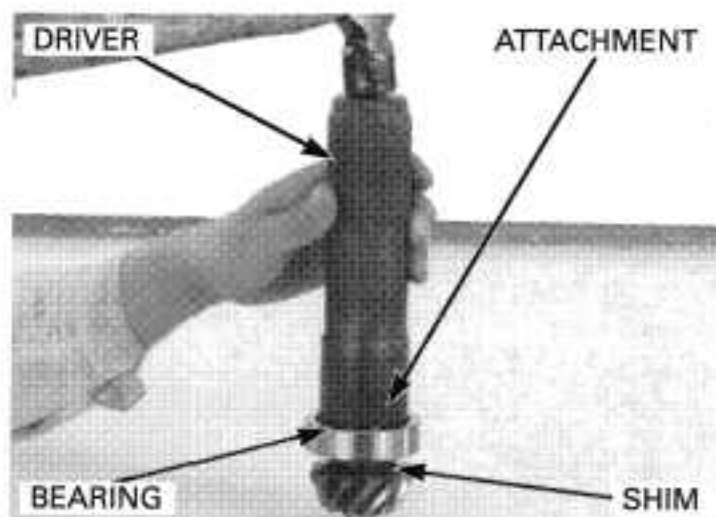



## FINAL DRIVE

Remove the O-ring and oil seal from the pinion retainer.

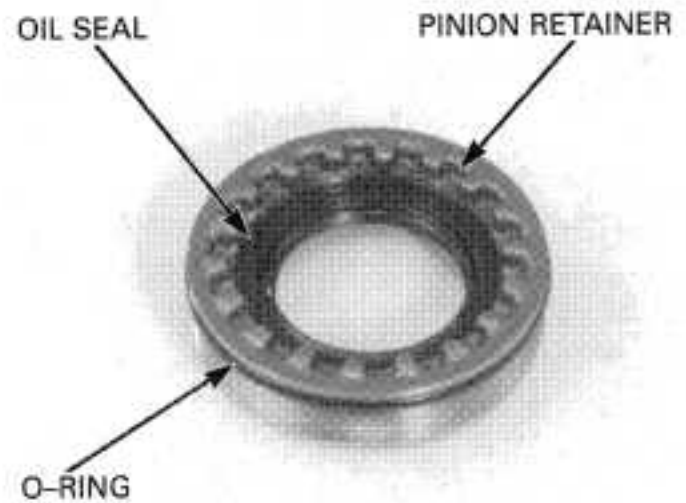

Drive a new oil seal into the retainer using the special tools.

**TOOLS:**

Driver 07749-0010000  
Attachment, 52 x 55 mm 07746-0010400

Pack grease into the seal lip cavity.

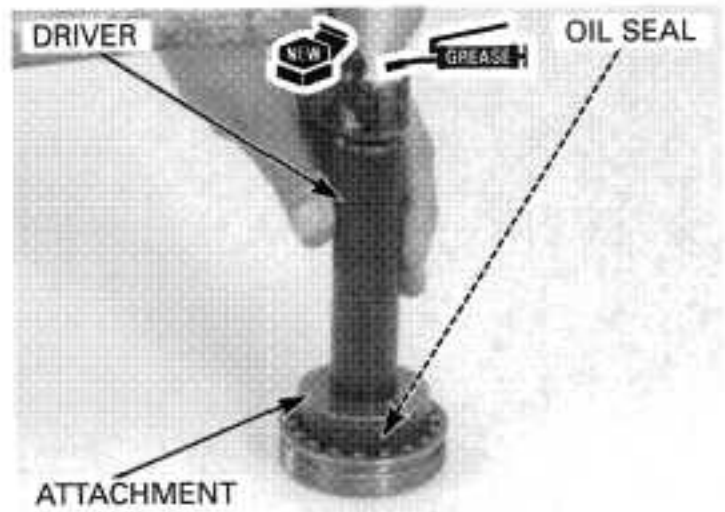

Coat a new O-ring with grease and install it on the retainer.

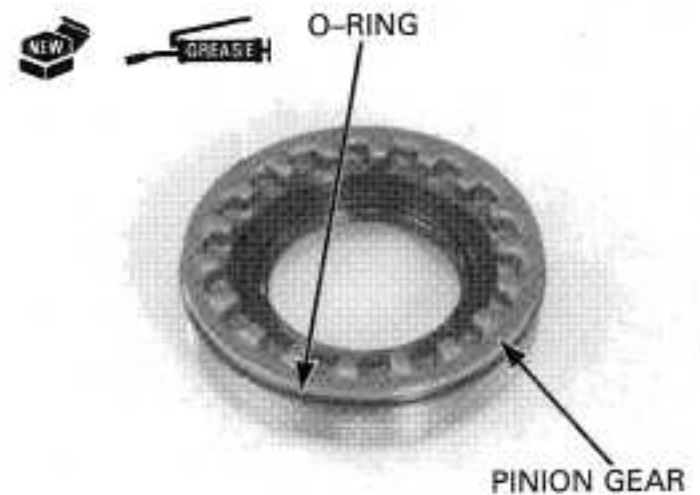

Place the gear case in a vise with soft jaws.

Drive the pinion assembly into the gear case until enough threads are visible to accept the pinion retainer to avoid damaging the gear case.

**TOOLS:**

Driver, 40 mm I.D. 07746-0030100  
Attachment, 30 mm I.D. 07746-0030300

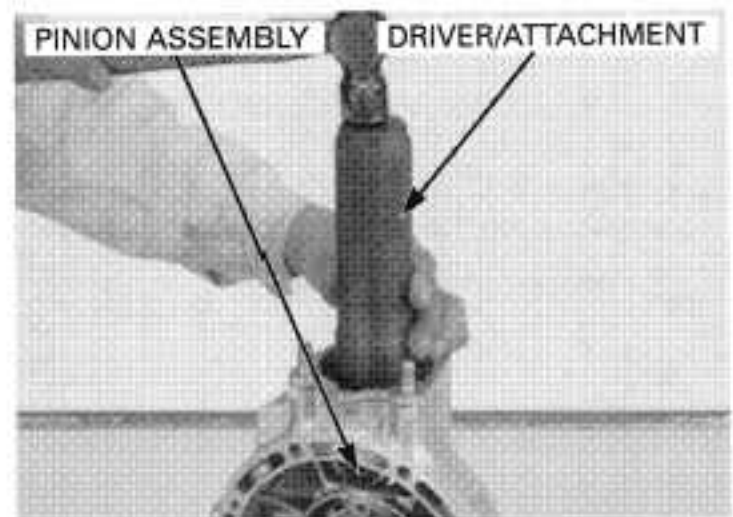

Screw the pinion retainer in, pressing the pinion bearing in place, then tighten the retainer to the specified torque.

**TOOL:**  
**Retainer wrench** 07910-4630100

**TORQUE:** 147 N·m (15.0 kgf·m, 108 lbf·ft)

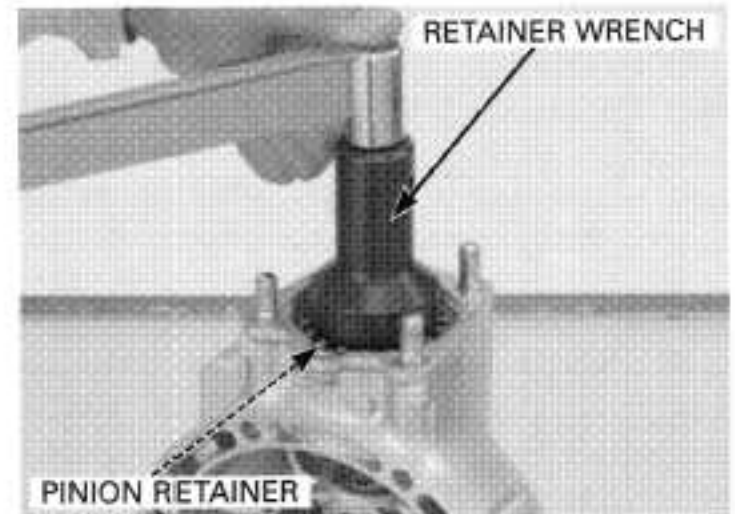

*The lock tab plate is available in the two types shown.*

Install a lock tab, depending on the position of the pinion retainer grooves in relation to the lock tabs.

Install and tighten the lock tab bolt.

**TORQUE:** 10 N·m (1.0 kgf·m, 7 lbf·ft)

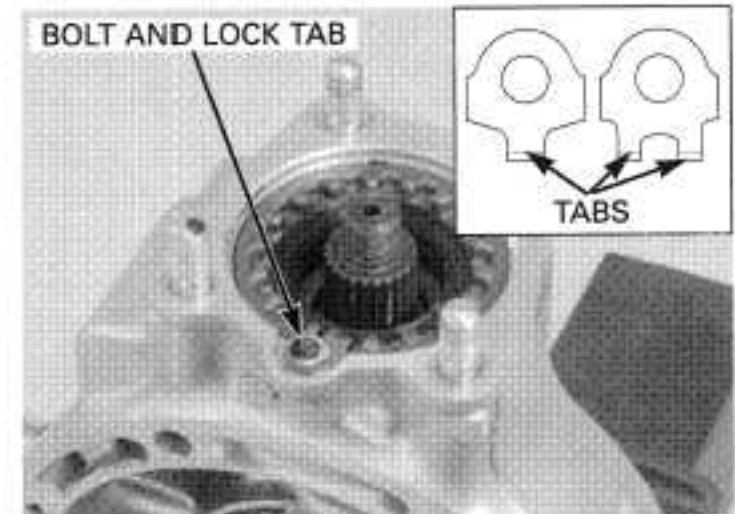

Install the pinion joint to the pinion gear shaft.

Apply locking agent to the threads of the pinion joint nut and screw in it by hand as far as it goes.

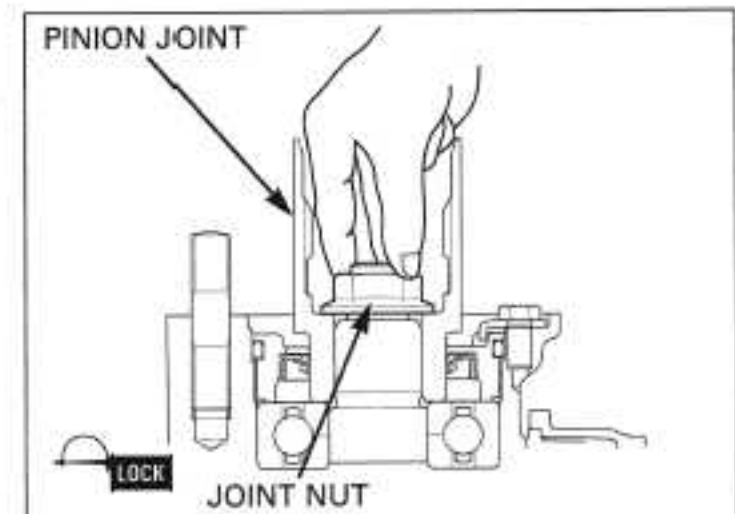

Hold the pinion joint using the pinion holder plate and collars.  
 Tighten the pinion joint nut.

**TOOLS:**  
**Pinion holder plate** 07924-ME40010  
**Collar set "C"** 07924-ME40020

**TORQUE:** 108 N·m (11.0 kgf·m, 80 lbf·ft)

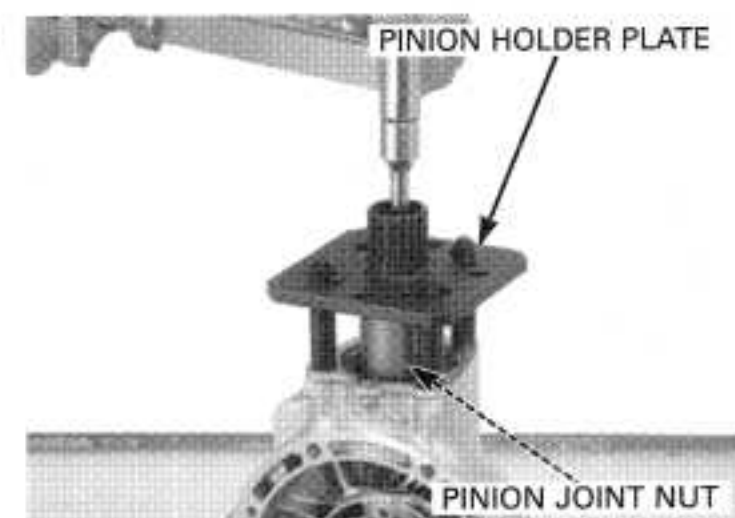

## FINAL DRIVE

### CASE BEARING REPLACEMENT

*Always wear insulated gloves when handling the heated gear case.*

Remove the ring gear and pinion gear.  
Heat the gear case to 80 °C (176 °F) evenly using a heat gun.

**TOOLS:**

**Bearing remover**  
**Remover handle**  
**Remover weight**

**07936-3710300**  
**07936-3710100**  
**07936-371020A or**  
**07936-3710200**

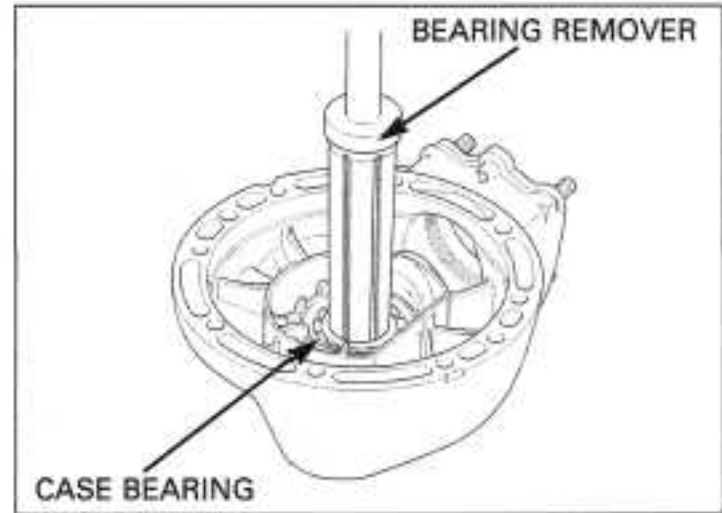

Remove the oil seal and discard it.

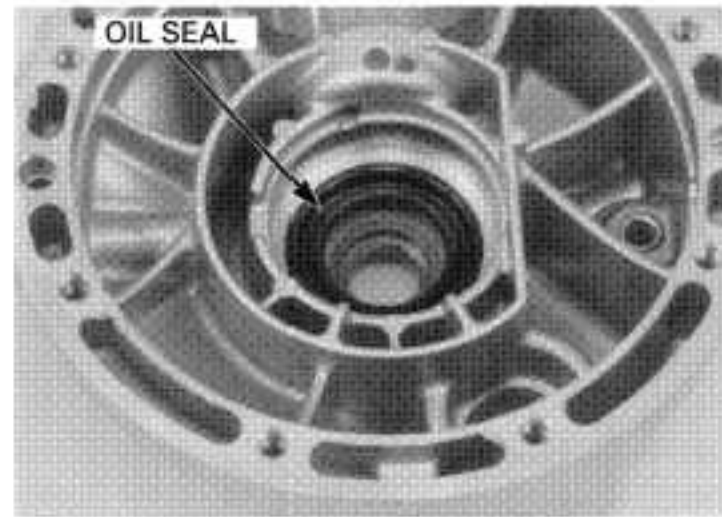

Drive a new oil seal into the gear case using the special tools.

**TOOLS:**

**Driver**  
**Attachment, 52 x 55 mm**

**07749-0010000**  
**07746-0010400**

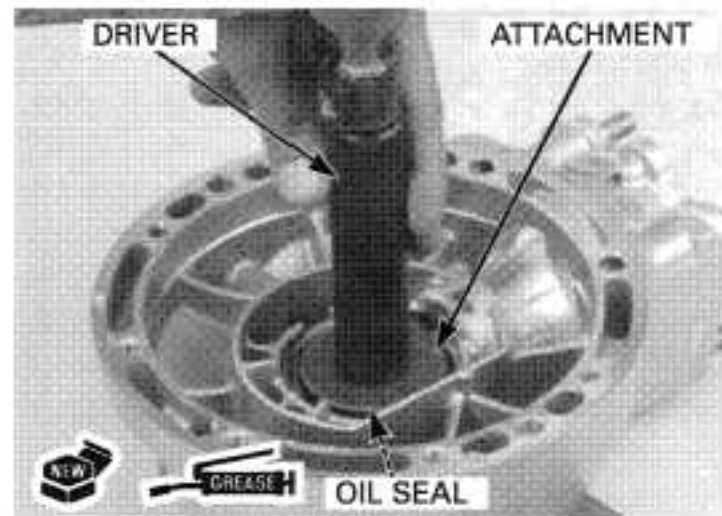

Drive a new ring gear bearing into the gear case using the special tools.

**TOOLS:**

**Driver**  
**Attachment, 52 x 55 mm**  
**Pilot, 35 mm**

**07749-0010000**  
**07746-0010400**  
**07746-0040800**

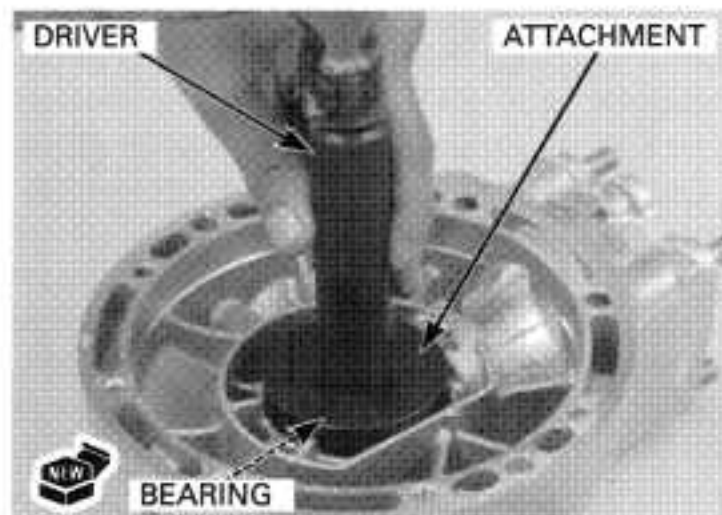

**BREATHER HOLE CLEANING**

To avoid damaging the breather cap, remove it before blowing compressed air through the breather hole.

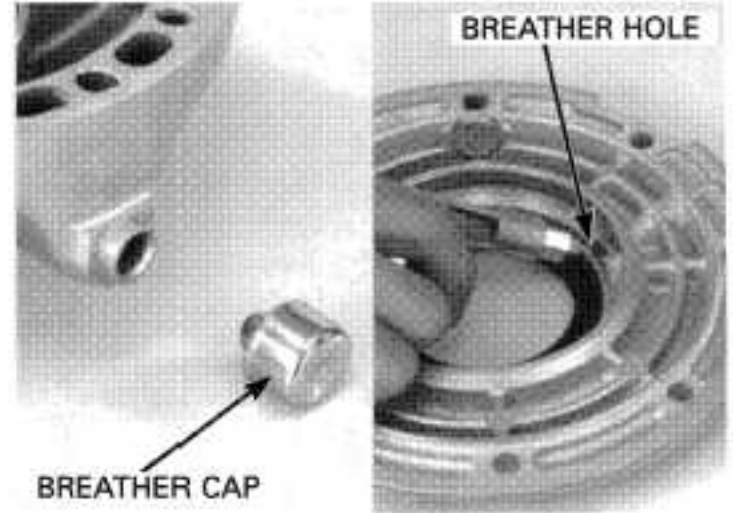

**GEAR CASE ASSEMBLY**

Clean all sealing material off the mating surfaces of the gear case cover.

Apply liquid sealant to the mating surface of the gear case and cover. Do not apply sealant around the dowel holes.

Install the ring gear and gear case cover with the wave washer.

Tighten the cover bolts in two or three steps until the cover evenly touches the gear case, then tighten the 8-mm bolts to the specified torque in a crisscross pattern in two or more steps.

Next, apply locking agent to the 10-mm bolt threads and tighten them to the specified torque.

**TORQUE: 8-mm: 25 N·m (2.6 kgf·m, 19 lbf·ft)**  
**10-mm: 62 N·m (6.3 kgf·m, 46 lbf·ft)**

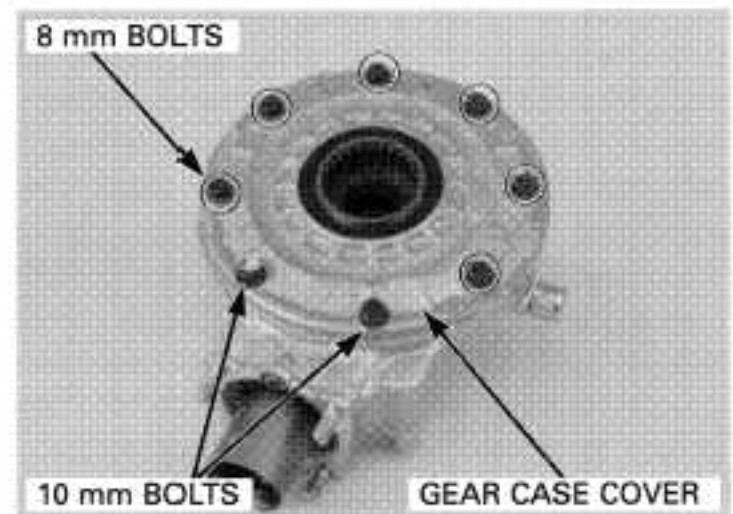
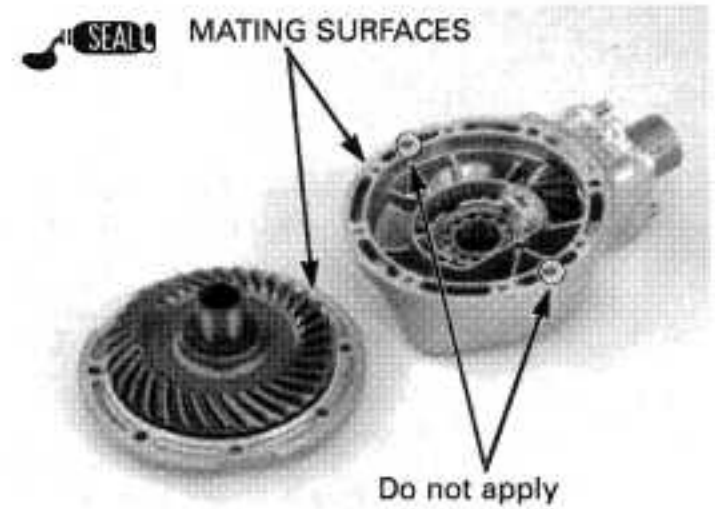

Make sure the gear assembly rotates smoothly without binding.

Measure the final gear assembly preload.

**PRELOAD: 0.2 – 0.4 N·m (2 – 4 kgf·m, 1.7 – 3.5 lbf·ft)**

If the preload reading does not fall within the limit, disassemble the final gear and check the bearings for proper installation.

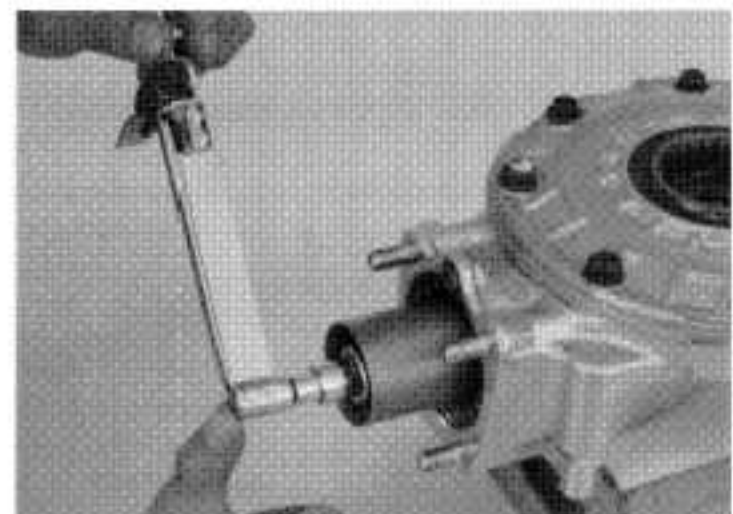



## FINAL DRIVE

Install the dust guard plate by aligning the plate tabs with the case cover grooves and turn it clockwise to lock.

Tighten the guard plate bolt.

**TORQUE: 10 N·m (1.0 kgf·m, 7 lbf·ft)**

Install the distance collar with the polished side facing the gear case.

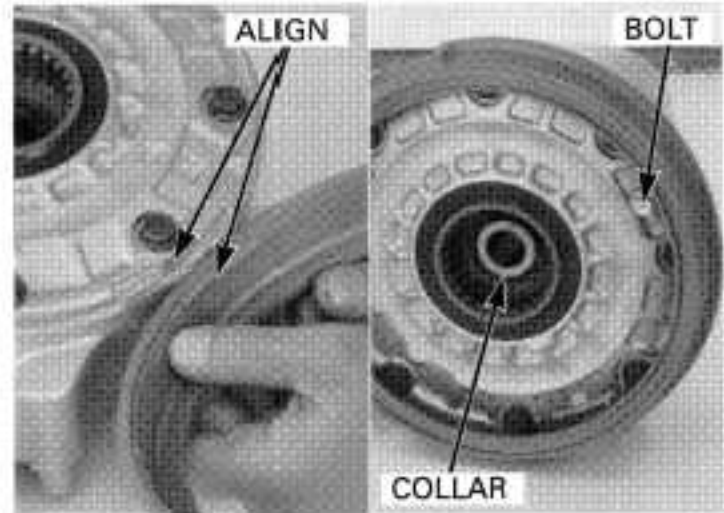

## FINAL DRIVE INSTALLATION

Check that the final gear case stud bolts are tight. If any are loose, remove them, clean their threads with contact cleaner, then install them using locking agent.

After installation, be sure to measure the distance from the top of each stud to the final gear case surface as shown.

If the universal joint was removed, install the universal joint and swingarm (page 14-14).

### DRIVE SHAFT ASSEMBLY/INSTALLATION

Install a new stopper ring.

Install the spring and new oil seal and pack 0.5 g (0.02 oz) of molybdenum disulfide grease into seal lip cavity.

Pack 2 g (0.08 oz) of molybdenum disulfide grease into the pinion joint spline.

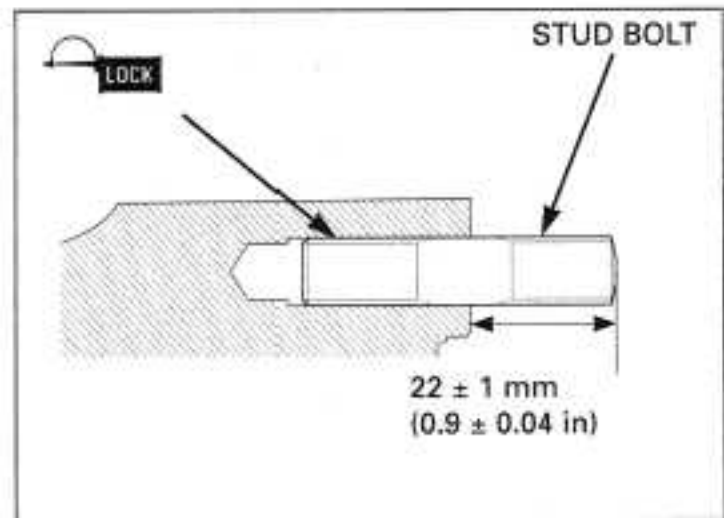

*Make sure the stopper ring is seated properly by pulling on the drive shaft lightly. Be careful not to damage the drive shaft oil seal.*

Install the drive shaft into the pinion joint until the stopper ring seats in the pinion joint spline groove.

Pack 1 g (0.04 oz) of molybdenum disulfide grease into the drive shaft spline.

Insert the final drive assembly into the swingarm and align the splines with the universal joint by holding the swingarm.

Install the gear case mounting nuts and shock absorber lower mounting bolt and tighten them to the specified torque.

**TORQUE:**

**Final gear case mounting nut:**

**64 N·m (6.5 kgf·m, 47 lbf·ft)**

**Rear shock absorber mounting bolt:**

**26 N·m (2.7 kgf·m, 20 lbf·ft)**

Install the rear wheel (page 14-9).

Fill the gear case with the recommended final drive oil (page 3-18).

**OIL CAPACITY: 150 cm<sup>3</sup> (5.1 US oz, 5.3 Imp oz) at disassembly**

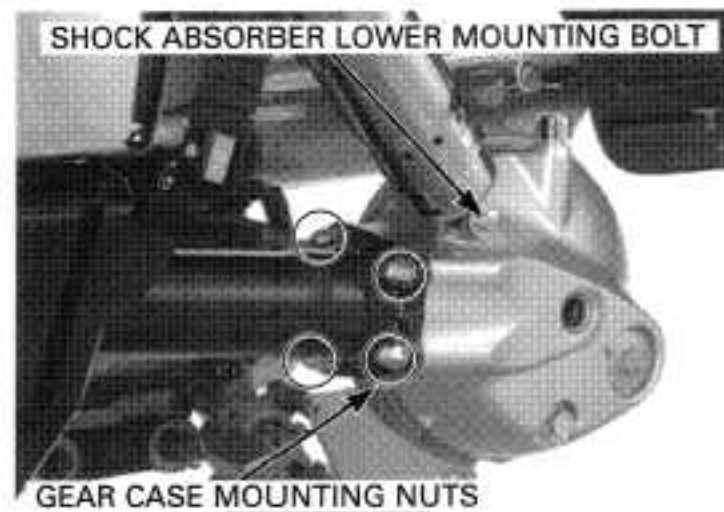
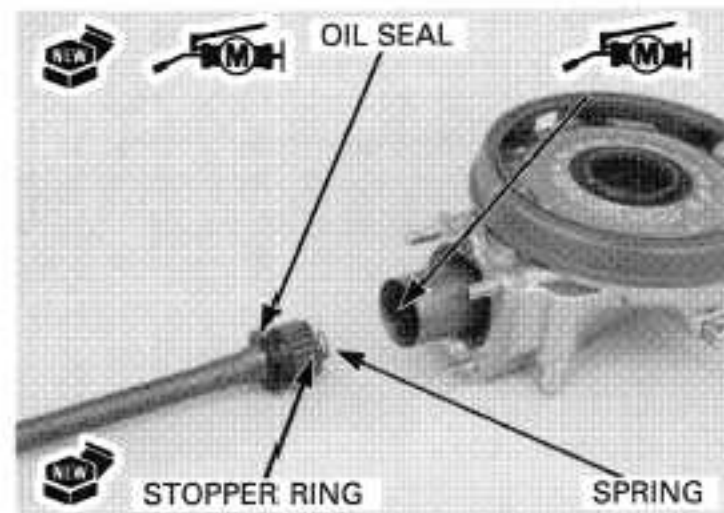



# FRONT WHEEL/SUSPENSION/STEERING

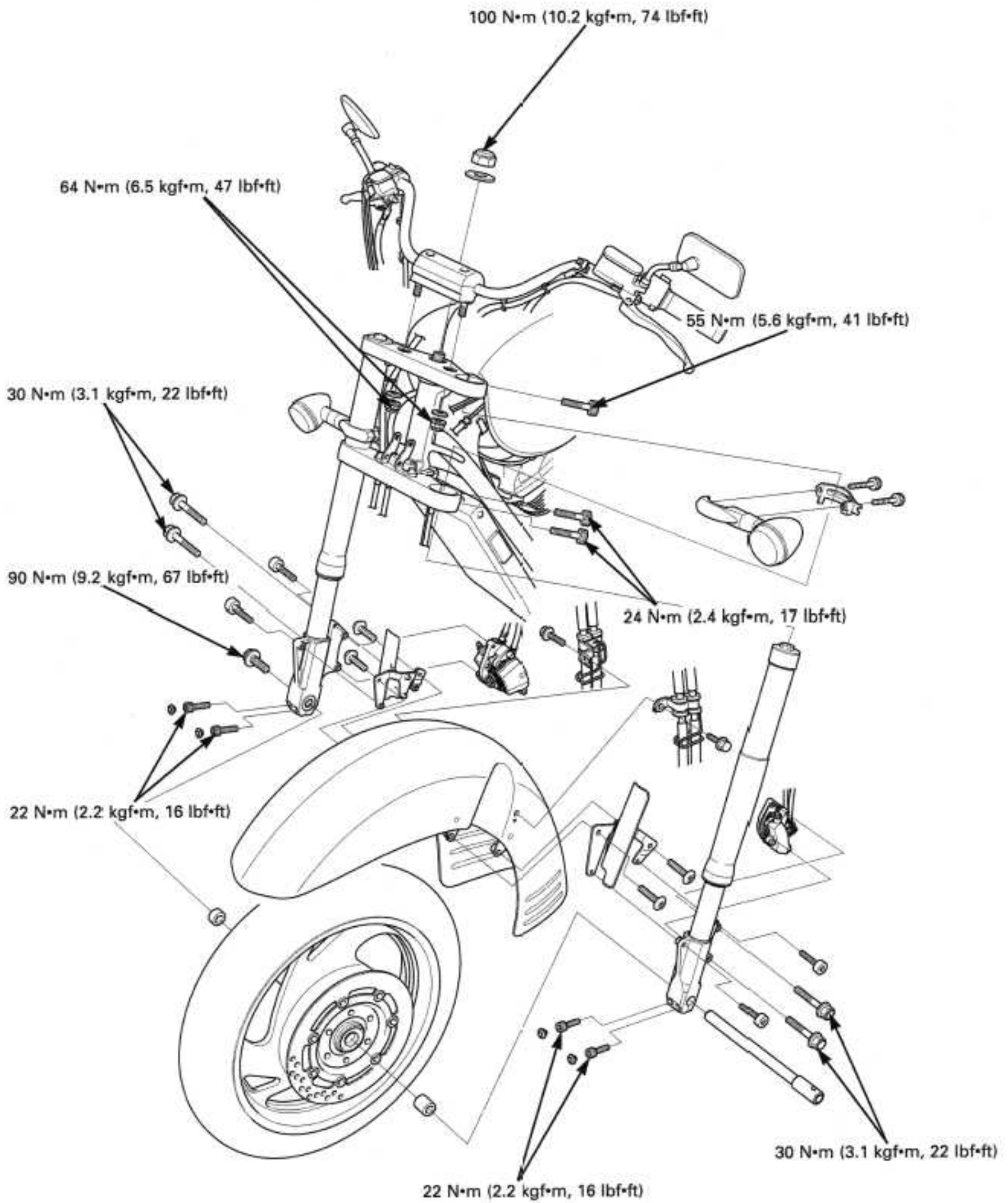

# 13. FRONT WHEEL/SUSPENSION/STEERING

<b>SERVICE INFORMATION</b>	<b>13-1</b>	<b>FRONT WHEEL</b>	<b>13-8</b>
<b>TROUBLESHOOTING</b>	<b>13-2</b>	<b>FORK</b>	<b>13-14</b>
<b>HANDLEBAR</b>	<b>13-3</b>	<b>STEERING STEM</b>	<b>13-32</b>

## SERVICE INFORMATION

### GENERAL

- A contaminated brake disc or pad reduces stopping power. Discard contaminated pads and clean a contaminated disc with a high quality brake degreasing agent.
- Raise the front wheel off the ground by supporting the frame securely.
- Refer to section 15 for hydraulic brake service.
- Refer to section 19 for light, meter and switch service.

### SPECIFICATION

Unit: mm (in)

ITEM		STANDARD	SERVICE LIMIT	
Minimum tire tread depth		—	1.5 (0.06)	
Cold tire pressure	Up to 90 kg (200 lb) load	225 kPa (2.25 kgf/cm <sup>2</sup> , 33 psi)	—	
	Up to maximum weight capacity	225 kPa (2.25 kgf/cm <sup>2</sup> , 33 psi)	—	
Axle runout		—	0.2 (0.01)	
Wheel rim runout	Radial	—	2.0 (0.08)	
	Axial	—	2.0 (0.08)	
Wheel balance weight		—	60 g (2.1 oz) max.	
Fork	Spring free length	Right	348.4 (13.72)	
		Left	348.4 (13.72)	
	Slider runout		—	0.20 (0.008)
	Recommended fork fluid		Pro Honda Suspension Fluid SS-8	
	Fluid level	Right	102 (4.1)	—
		Left	101 (4.0)	—
	Fluid capacity	Right	696 ± 2.5 cm <sup>3</sup> (23.5 ± 0.08 US oz, 24.5 ± 0.09 Imp oz)	—
Left		780 ± 2.5 cm <sup>3</sup> (26.4 ± 0.08 US oz, 27.5 ± 0.09 Imp oz)	—	
Steering head bearing pre-load		7.8 – 11.8 N (0.8 – 1.2 kgf)	—	

**13**

## FRONT WHEEL/SUSPENSION/STEERING

---

### TORQUE VALUES

Handlebar upper holder bolt	26 N•m (2.7 kgf•m, 20 lbf•ft)	
Handlebar lower holder nut	64 N•m (6.5 kgf•m, 47 lbf•ft)	U-nut.
Front axle bolt	90 N•m (9.2 kgf•m, 67 lbf•ft)	
Front axle holder bolt	22 N•m (2.2 kgf•m, 16 lbf•ft)	
Front brake disc bolt	20 N•m (2.0 kgf•m, 14 lbf•ft)	ALOC bolt: replace with a new one.
Steering stem nut	100 N•m (10.2 kgf•m, 74 lbf•ft)	
Top adjusting nut A	17 N•m (1.7 kgf•m, 12 lbf•ft)	
Top adjusting nut B	—	
Fork top bridge pinch bolt	55 N•m (5.6 kgf•m, 41 lbf•ft)	
Fork bottom bridge pinch bolt	24 N•m (2.4 kgf•m, 17 lbf•ft)	
Fork cap	34 N•m (3.5 kgf•m, 25 lbf•ft)	
Fork socket bolt	20 N•m (2.0 kgf•m, 14 lbf•ft)	Apply locking agent to the threads.
Fork cap lock nut	20 N•m (2.0 kgf•m, 14 lbf•ft)	
Inner fork bolt	98 N•m (10.0 kgf•m, 72 lbf•ft)	
Front caliper mounting bolt	30 N•m (3.1 kgf•m, 22 lbf•ft)	ALOC bolt: replace with a new one.

### TOOLS

Attachment, 37 x 40 mm	07746-0010200
Attachment, 42 x 47 mm	07746-0010300
Attachment, 52 x 55 mm	07746-0010400
Pilot, 20 mm	07746-0040500
Pilot, 35 mm	07746-0040800
Bearing remover head, 20mm	07746-0050600
Driver	07749-0010000
Steering stem socket	07916-3710100
Bearing race remover	07946-3710500
Steering stem driver	07946-MB00000
Driver handle attachment	07949-3710001
Bearing remover shaft	07GGD-0010100
Fork seal driver, 45 mm	07KMD-KZ30100
Lock nut wrench, 36 x 44 mm	07VMA-MZ0010A

## TROUBLESHOOTING

### Hard steering

- Steering bearing adjustment nut too tight
- Worn or damaged steering bearings
- Worn or damaged steering bearing races
- Bent steering stem
- Insufficient tire pressure
- Faulty front tire

### Steers to one side or does not track straight

- Damaged or loose steering bearings
- Bent fork
- Bent front axle: wheel installed incorrectly
- Bent frame
- Faulty front tire
- Worn or damaged front wheel bearings
- Worn or damaged swingarm pivot bearings

### Front wheel wobbles

- Bent rim
- Worn or damaged front wheel bearings
- Faulty front tire
- Unbalanced tire and wheel
- Loose front axle fasteners

### Wheel turns hard

- Faulty front wheel bearings
- Bent front axle
- Brake drag

### Soft suspension

- Weak fork springs
- Insufficient fluid in fork
- Deteriorated fork fluid
- Incorrect fork fluid weight
- Low tire pressure

### Hard suspension

- Bent fork pipes
- Too much fluid in fork
- Incorrect fork fluid weight
- Clogged fork fluid passage
- High tire pressure

### Front suspension noise

- Worn slider or fork pipe bushing
- Insufficient fluid in fork
- Loose fork fasteners

## HANDLEBAR

### REMOVAL

Release the wire bands.

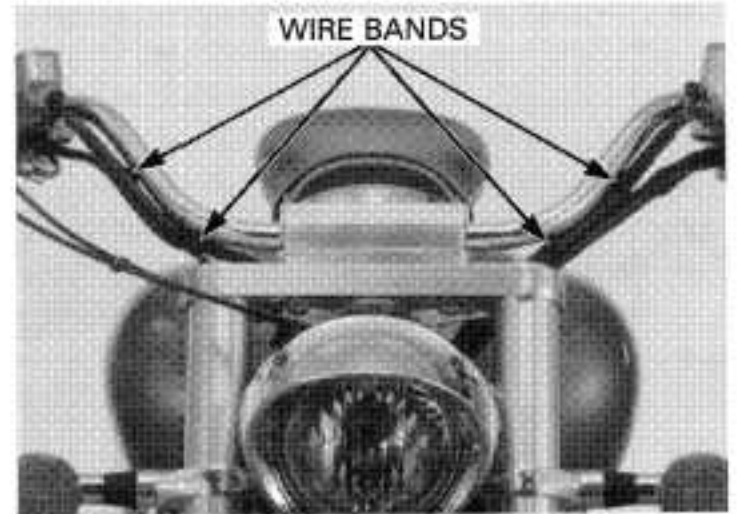

*Keep the master cylinder upright to prevent air from entering the hydraulic system.*

Disconnect the clutch switch connectors. Remove the bolts, master cylinder holder and clutch master cylinder from the handlebar.

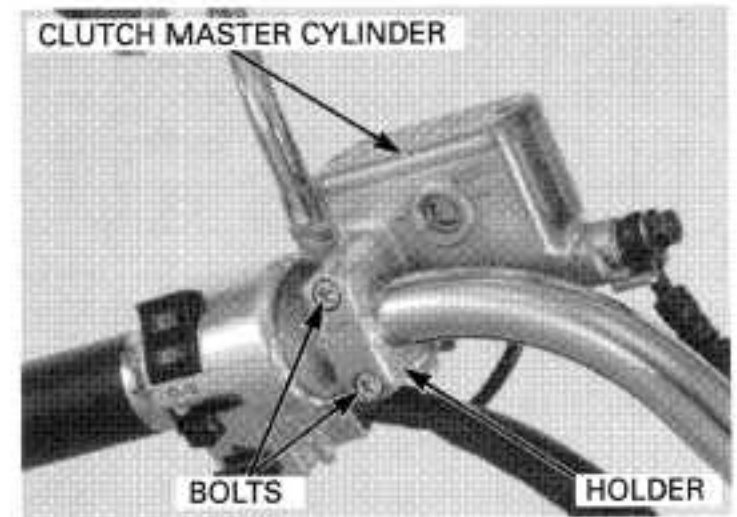

Remove the attaching screws and the left handlebar switch housing from the handlebar.

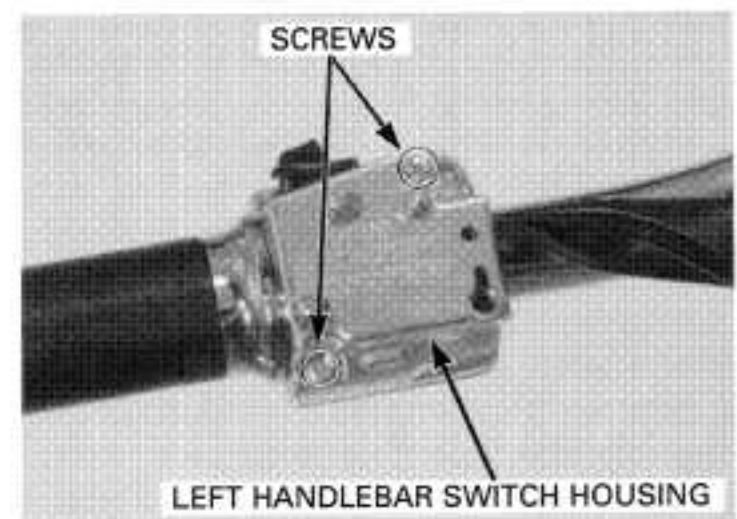

Remove the left handlebar grip end cap. Remove the left handlebar grip from the handlebar. Remove the left handlebar switch housing end.

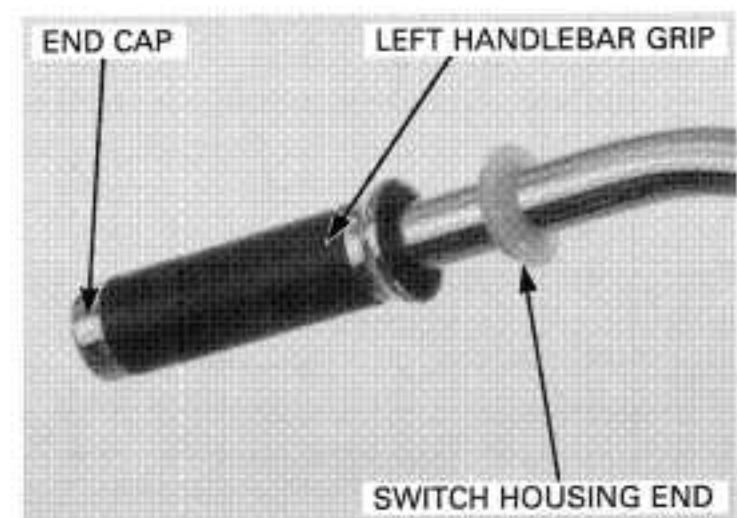



## FRONT WHEEL/SUSPENSION/STEERING

*Keep the master cylinder upright to prevent air from entering the hydraulic system.*

Disconnect the front brake switch connectors. Remove the bolts, front brake master cylinder holder and master cylinder from the handlebar.

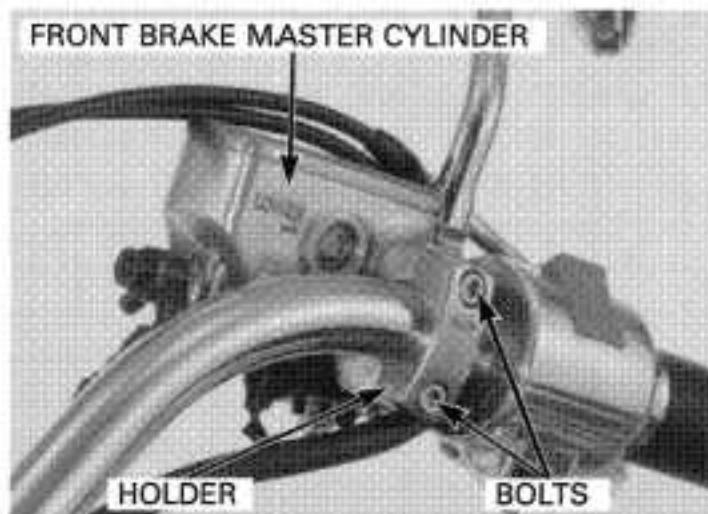

Remove the attaching screws.

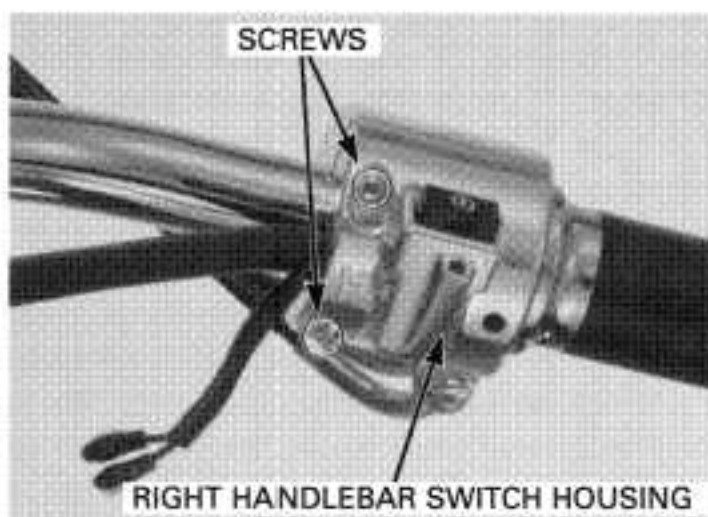

If the handlebar lower holder will be removed, loosen the lower holder nuts before removing the upper holder.

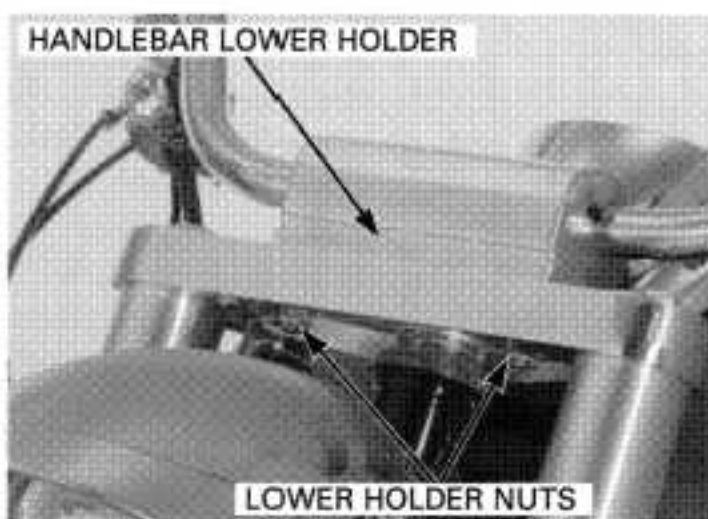

Remove the bolt caps.

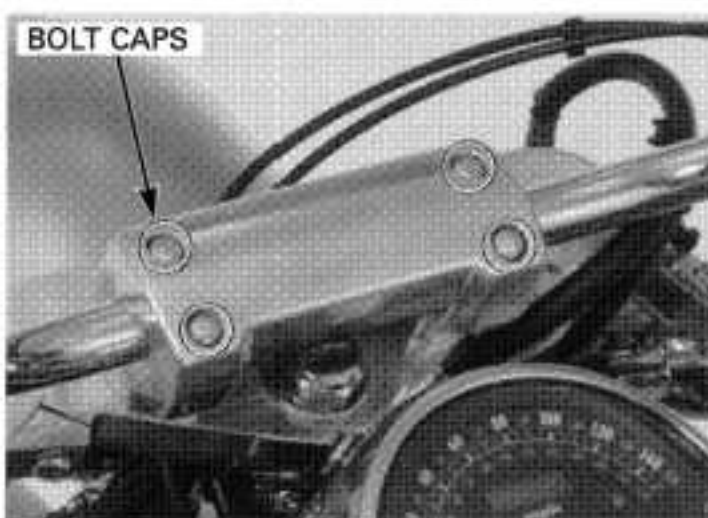



Remove the upper holder bolts and the handlebar upper holder.  
Remove the handlebar from the lower holders.

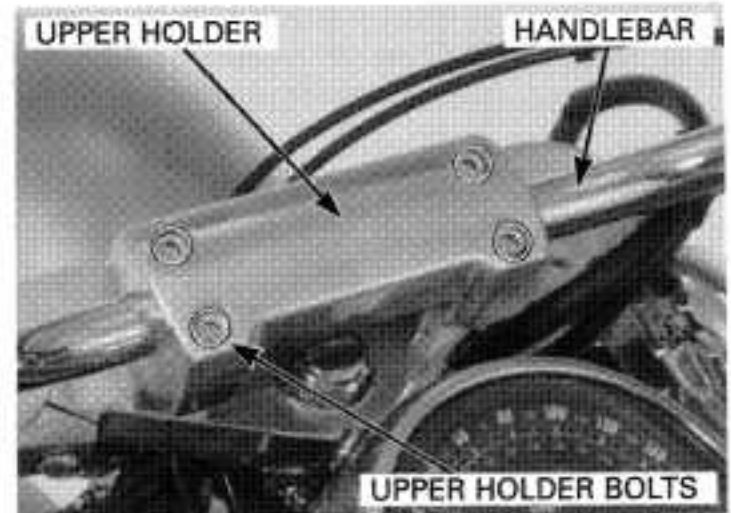

Move the handlebar to obtain sufficient slack in the throttle cables so they can be disconnected from the throttle grip flange.  
Remove the right handlebar switch housing from the handlebar.

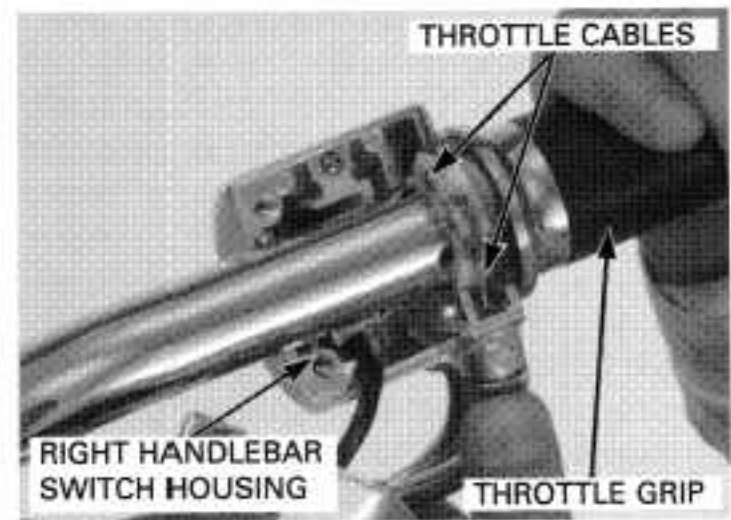

Remove the handlebar lower holder nuts, washers and the handlebar lower holder.

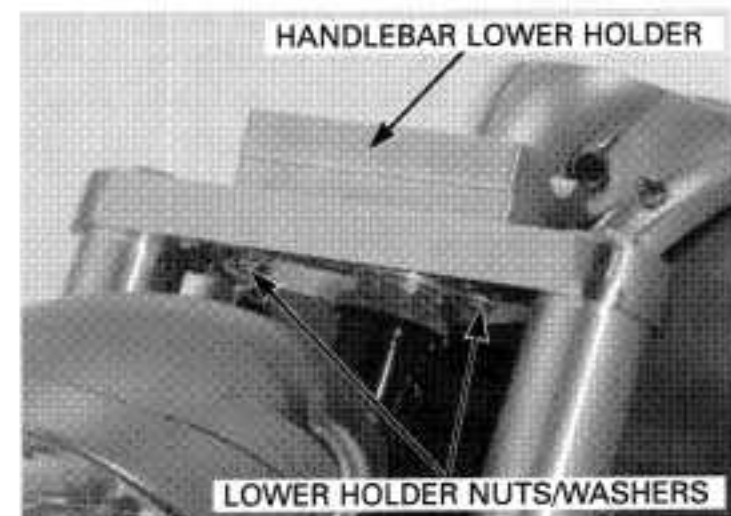

### INSTALLATION

*Do not tighten the lower holder nuts yet.*

Install the handlebar lower holder, washers and lower holder nuts.

Apply grease to the throttle grip flange groove.  
Connect the throttle cables to the throttle grip flange and install the throttle grip onto the handlebar.



## FRONT WHEEL/SUSPENSION/STEERING

Place the handlebar onto the lower holders and align the punch mark on the handlebar with the top of the lower holder.

Install the upper holder.

Install the upper holder bolts and tighten the forward bolts first, then tighten the rear bolts to the specified torque.

**TORQUE: 26 N·m (2.7 kgf·m, 20 lbf·ft)**

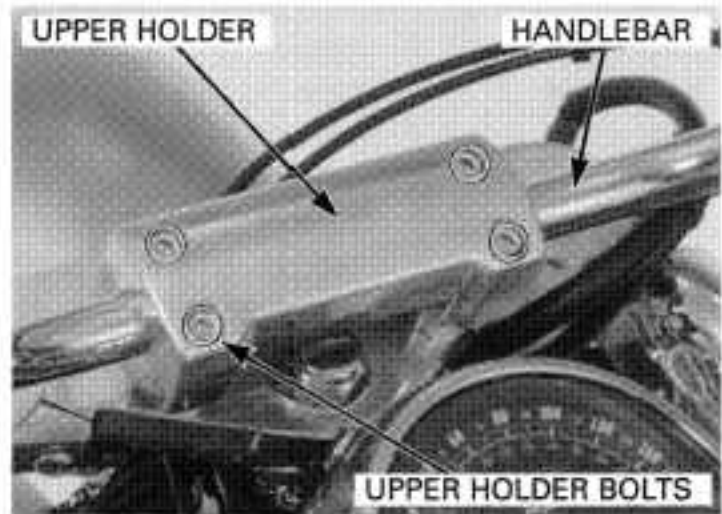

Install the bolt caps securely.

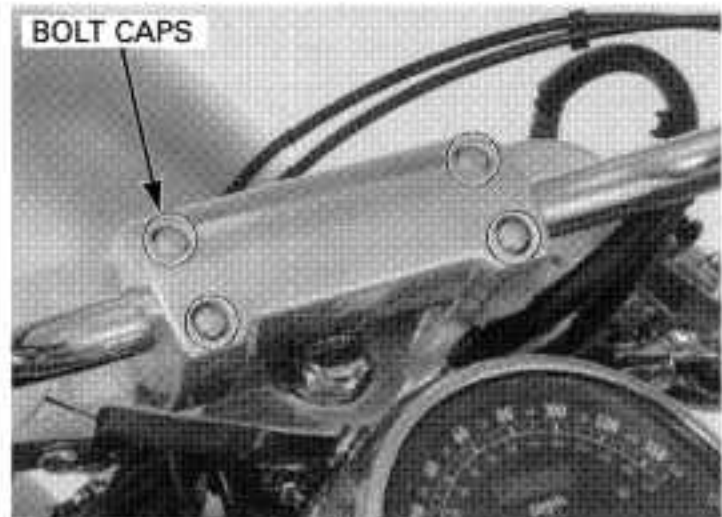

Tighten the lower holder nuts to the specified torque.

**TORQUE: 64 N·m (6.5 kgf·m, 47 lbf·ft)**

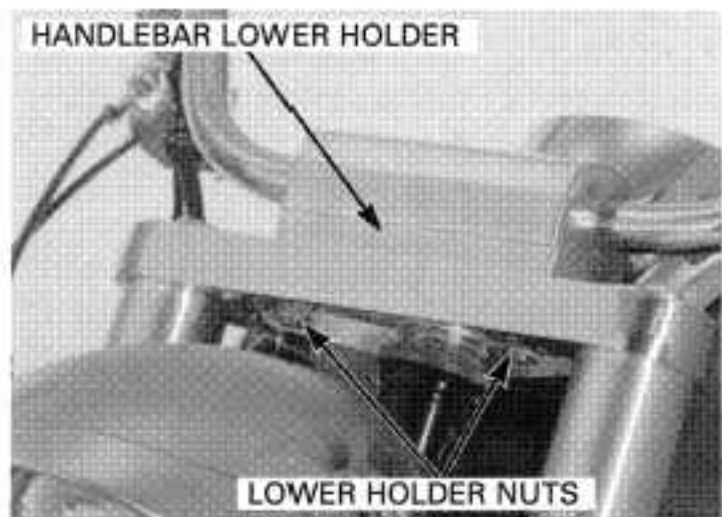

Install the right handlebar switch housing onto the handlebar, aligning the locating pin with the hole in the handlebar.

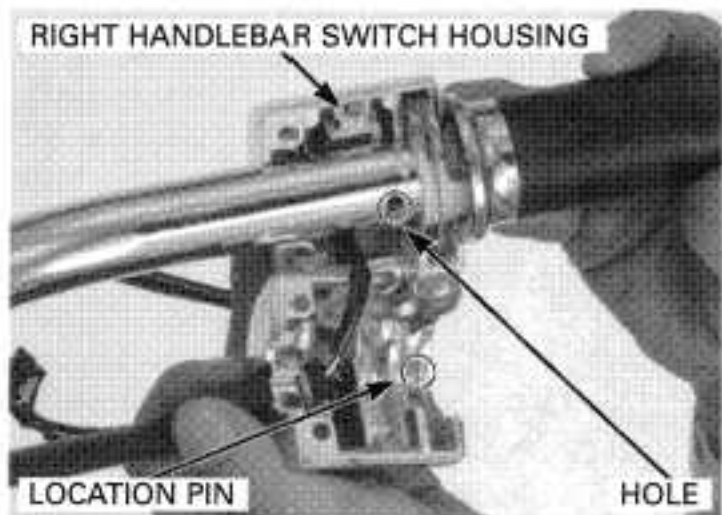

Install the attaching screws and tighten the forward screw first, then tighten the rear screw.

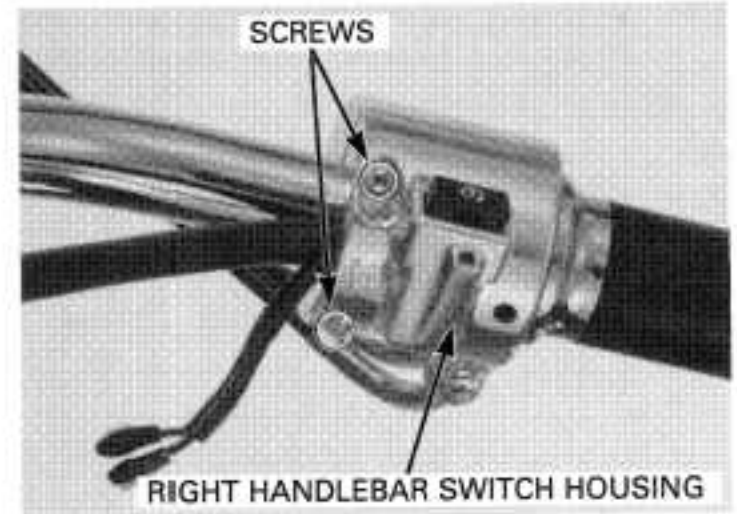

Install the master cylinder and holder with the "UP" mark facing up.

Align the end of the master cylinder with the punch mark on the handlebar and tighten the upper bolt first, then tighten the lower bolt.

**TORQUE: 12 N·m (1.2 kgf·m, 9 lbf·ft)**

Connect the front brake switch connectors.

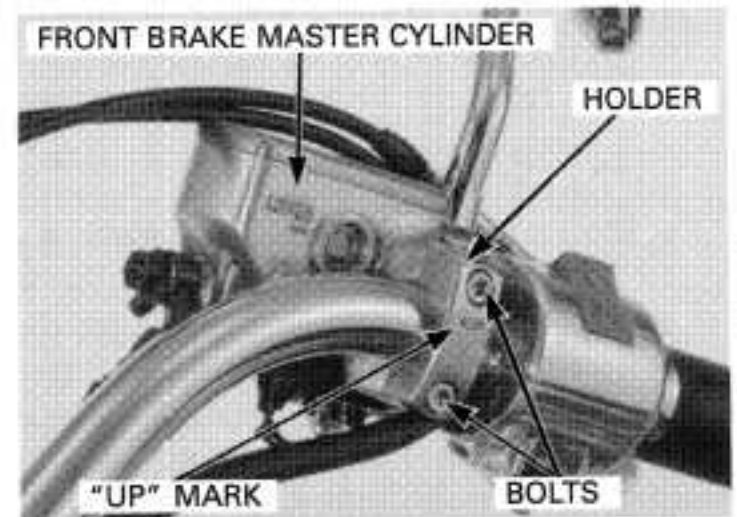

Install the left handlebar switch housing end.

Clean the inside surface of the left handlebar grip and the outside surface of the left handlebar. Apply Honda Bond A or Honda Grip Cement (U.S.A. only) to the inside surface of the left handlebar grip and to the outside surface of the left handlebar. Wait 3 – 5 minutes and install the grip. Rotate the grip for even application of the adhesive. Install the left handlebar grip end cap.

*Allow the adhesive to dry for 1 hour before using.*

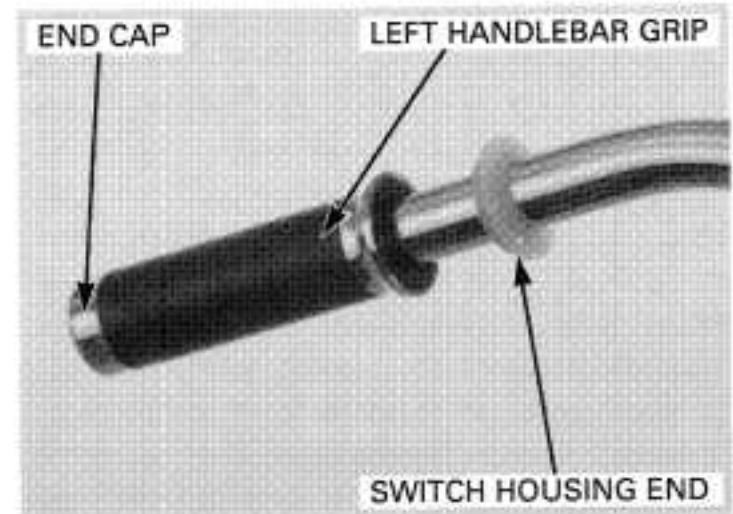

Install the left handlebar switch housing onto the handlebar, aligning the locating pin with the hole in the handlebar.

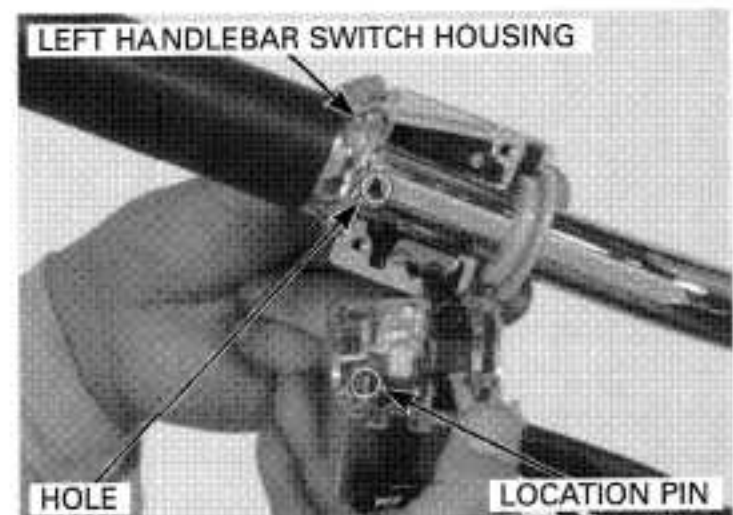

## FRONT WHEEL/SUSPENSION/STEERING

Install the attaching screws and tighten the forward screw first, then tighten the rear screw.

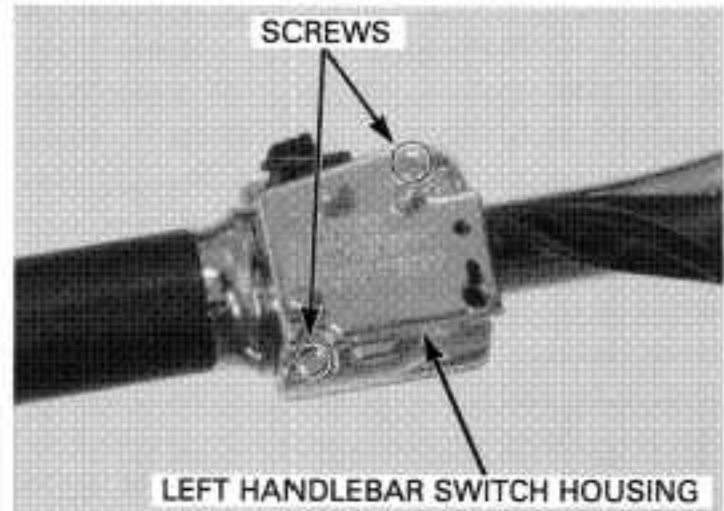

Install the clutch master cylinder and holder with the "UP" mark facing up. Align the end of the clutch master cylinder with the punch mark on the handlebar and tighten the upper bolt first, then tighten the lower bolt.

**TORQUE: 12 N·m (1.2 kgf·m, 9 lbf·ft)**

Connect the clutch switch connectors.

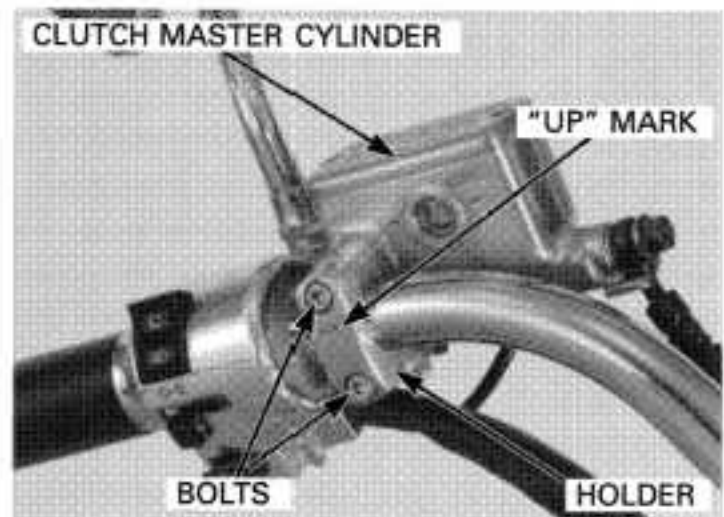

Install the wires to the wire bands.

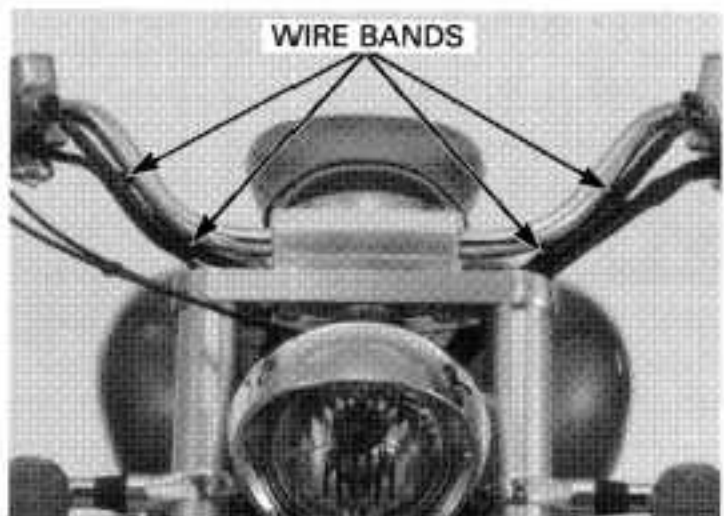

## FRONT WHEEL

### REMOVAL

Remove the front brake pads (page 15-10).

*Do not hang the brake calipers from the brake hoses.*

Remove the bolts, brake hose clamps, mounting bolts and both brake calipers.

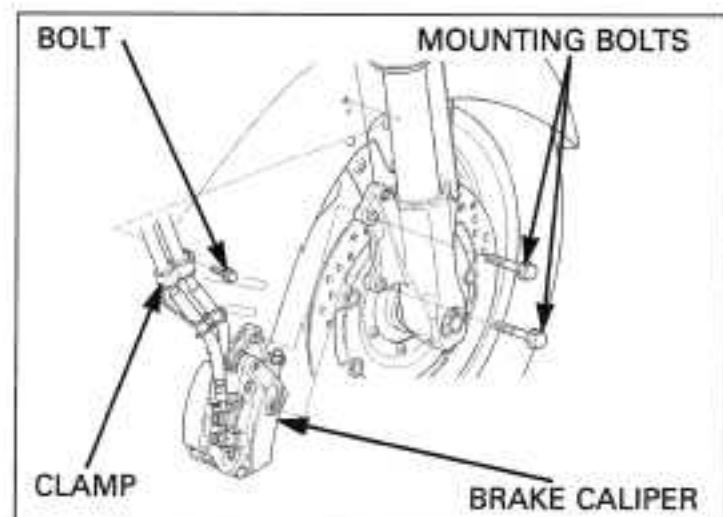



Remove the bolt caps from the right and left axle pinch bolts.

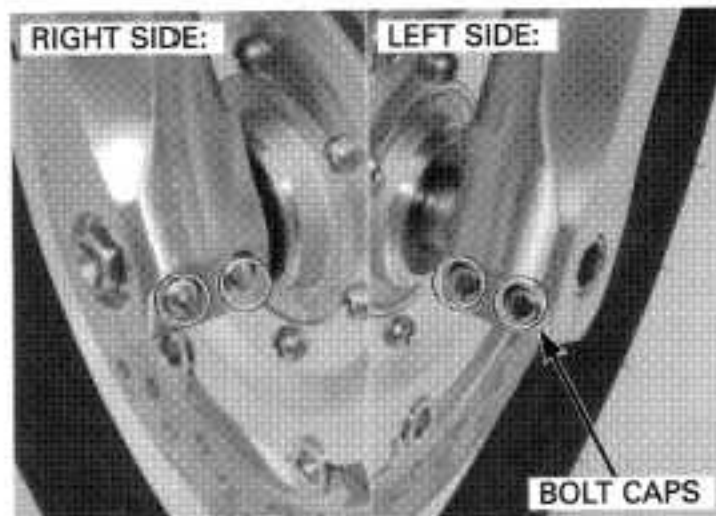

Loosen the right axle pinch bolts.  
Loosen the axle bolt.

Raise the front wheel off the ground by supporting the frame securely.

Remove the axle bolt.

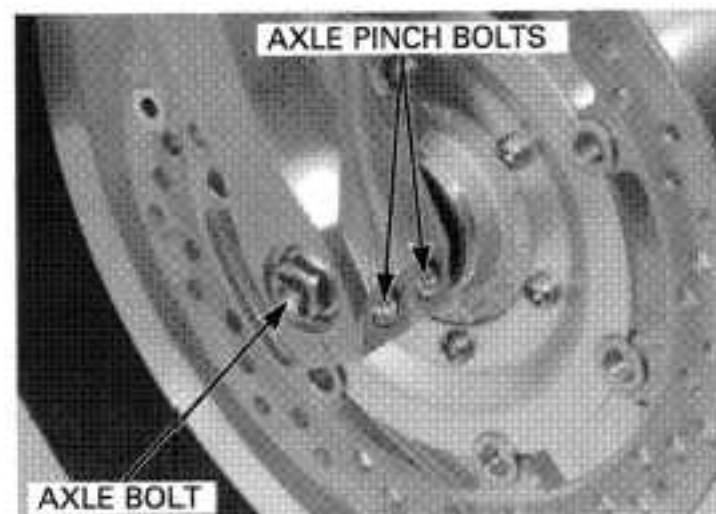

Loosen the left axle pinch bolts.  
Pull the front axle out and remove the front wheel.

*Do not operate the brake lever and brake pedal after removing the front wheel or it will be extremely difficult to separate the brake pads during installation.*

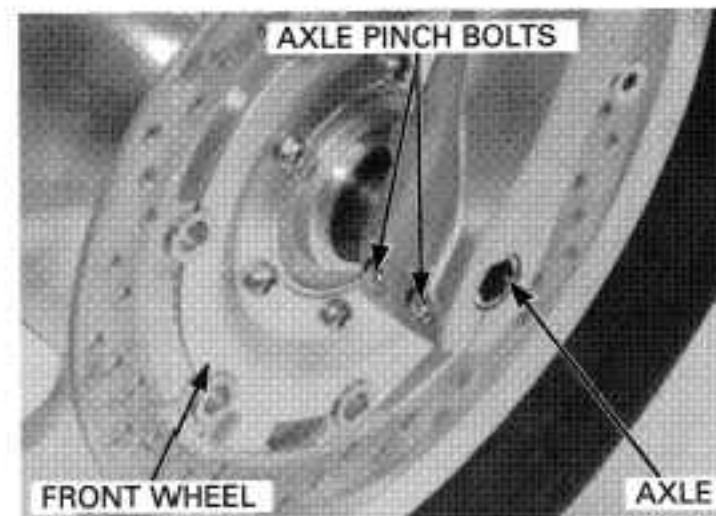

Remove the side collar from the right side of the wheel.

Remove the side collar from the left side of the wheel.

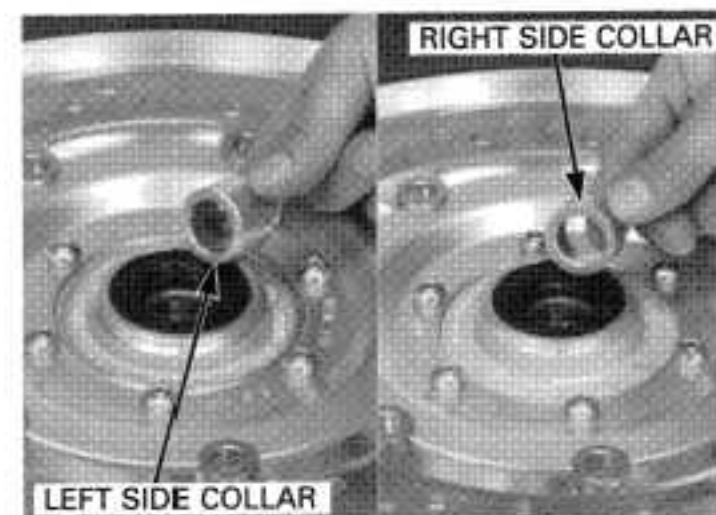



## FRONT WHEEL/SUSPENSION/STEERING

### INSPECTION

#### AXLE

Place the axle in V-blocks and measure the runout. Actual runout is 1/2 the total indicator reading.

**SERVICE LIMIT: 0.2 mm (0.01 in)**

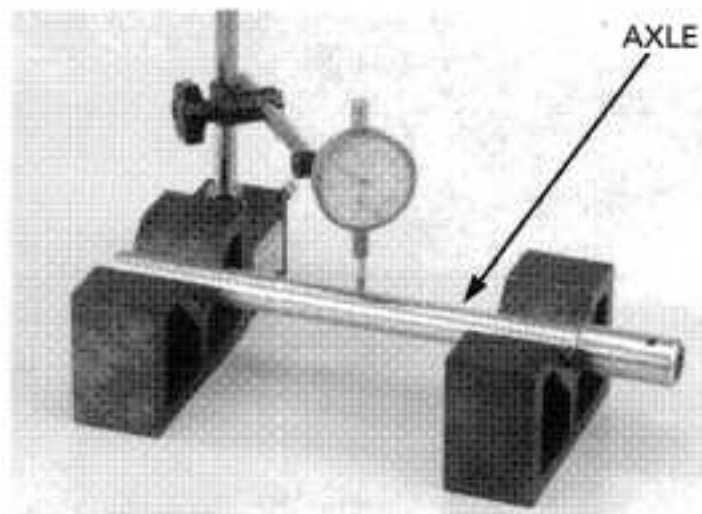

#### WHEEL

Check the rim runout by placing the wheel in a truing stand.

Spin the wheel slowly and read the runout using a dial indicator.

Actual runout is 1/2 the total indicator reading.

**SERVICE LIMIT: Radial: 2.0 mm (0.08 in)**

**Axial: 2.0 mm (0.08 in)**

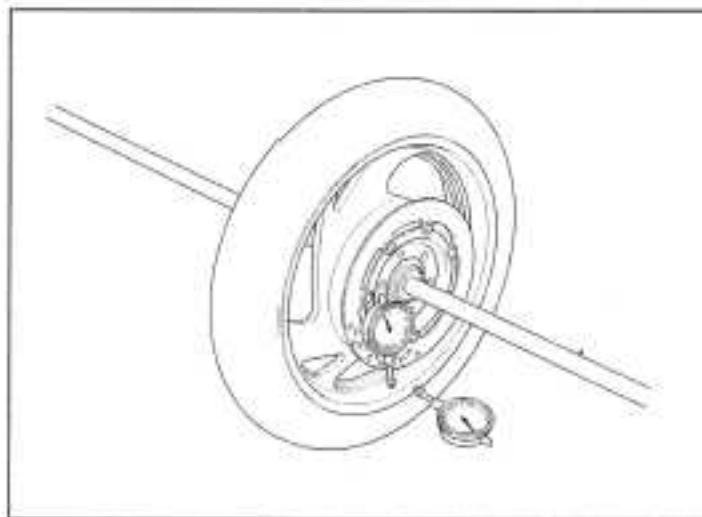

#### WHEEL BEARING

Turn the inner race of each bearing with your finger. The bearings should turn smoothly and quietly.

Also check that the bearing outer race fits tightly in the hub.

*Replace the wheel bearings in pairs.*

Remove and discard the bearings if the races do not turn smoothly, quietly, or if they fit loosely in the hub.

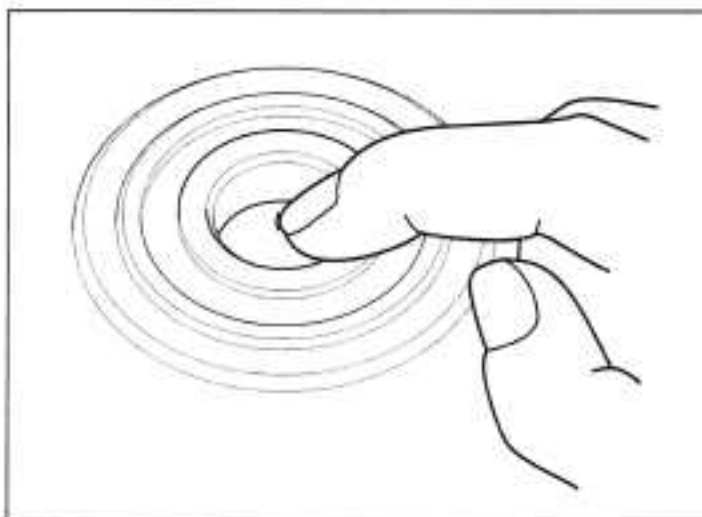

### DISASSEMBLY

Remove the dust seals from both sides of the wheel.

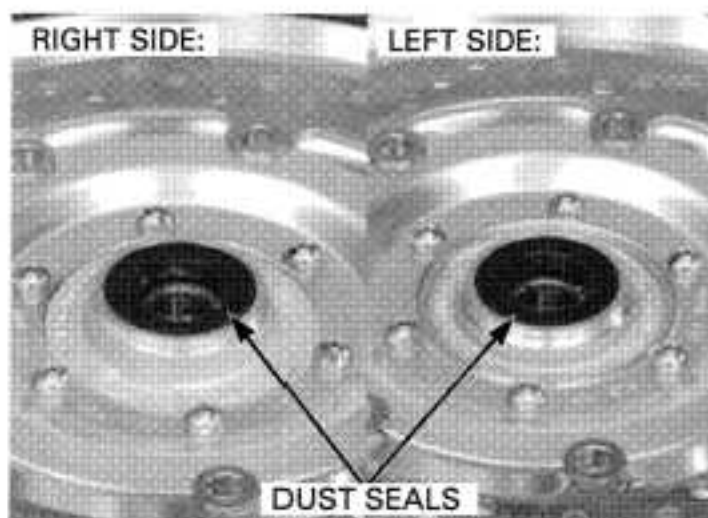

Remove the brake disc bolts and the brake discs from both sides of the wheel.

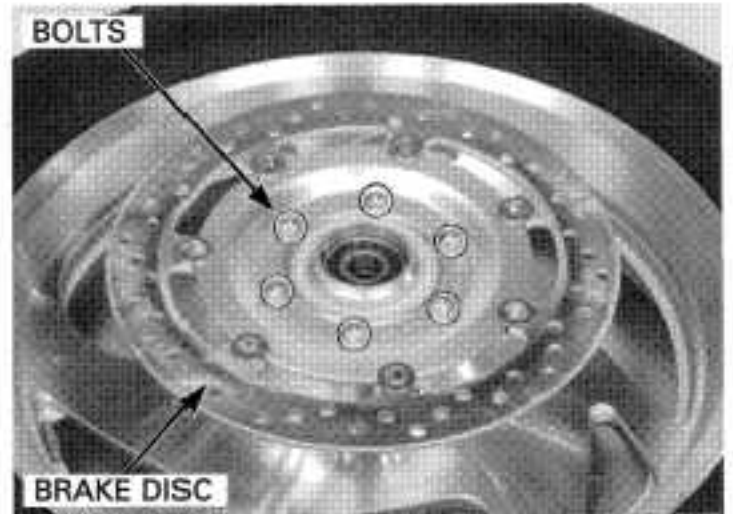

Install the bearing remover head into the bearing. From the opposite side of the wheel, install the bearing remover shaft and drive the bearing out of the wheel hub. Remove the distance collar and drive out the other bearing.

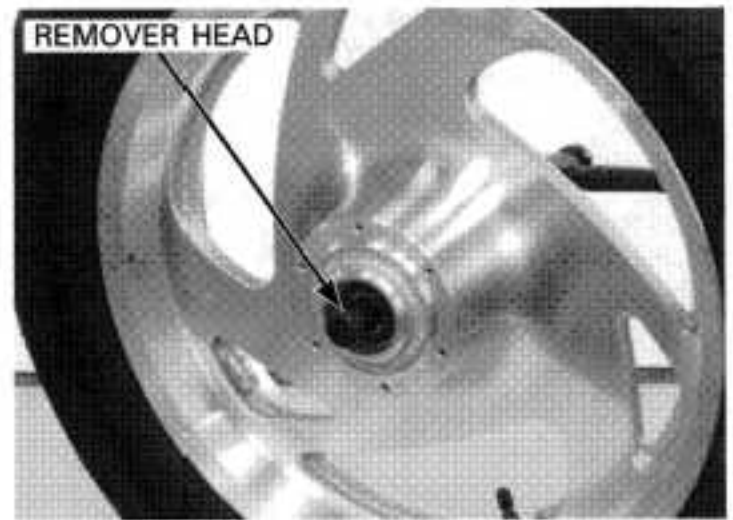

**TOOLS:**

- Bearing remover shaft 07GGD-0010100
- Bearing remover head, 20 mm 07746-C050600

**ASSEMBLY**

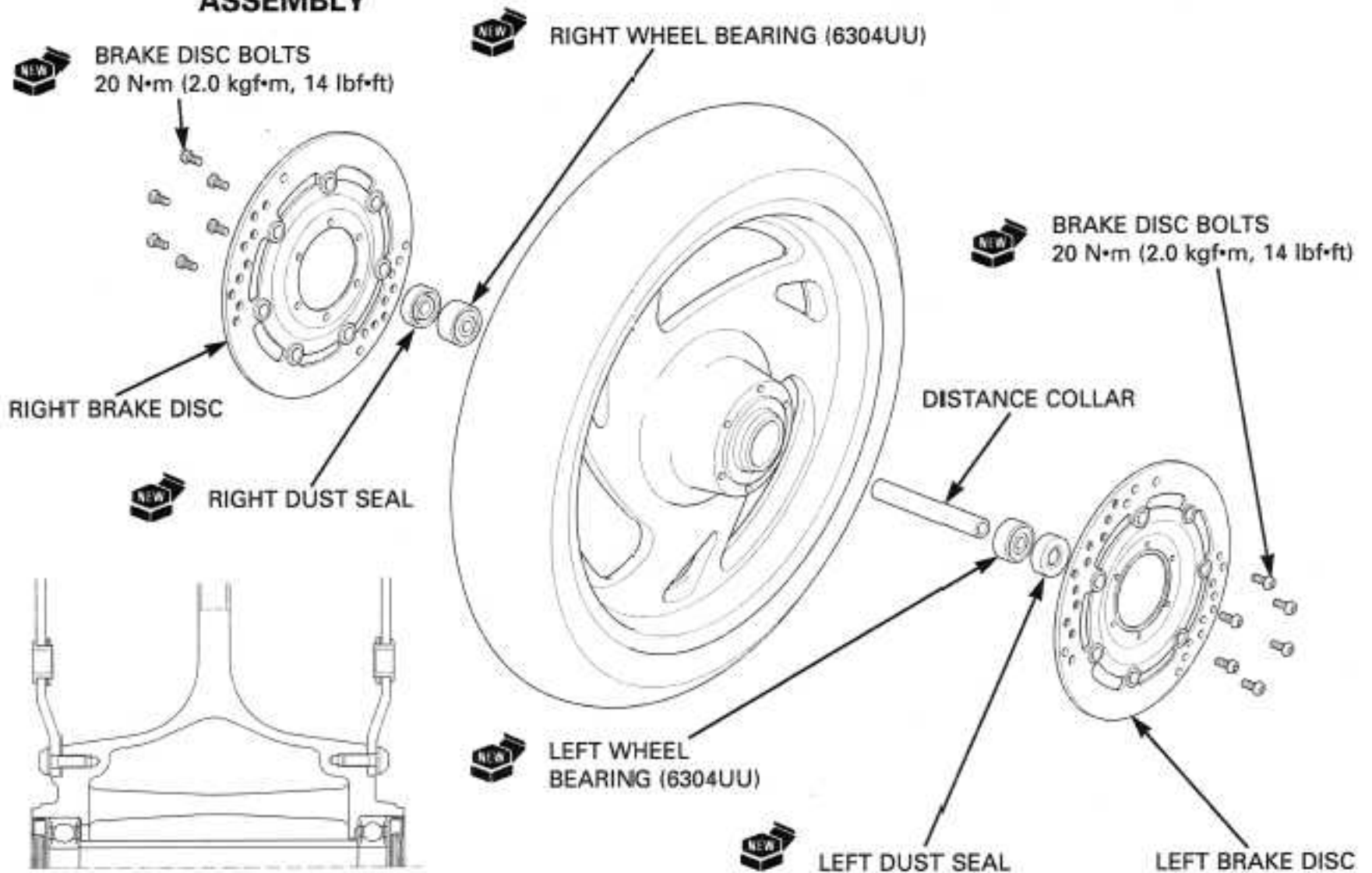

## FRONT WHEEL/SUSPENSION/STEERING

Drive in a new right bearing (6304 UU) squarely with the mark facing up until the bearing is fully seated. Install the distance collar. Drive in a new left bearing (6304 UU) squarely with the mark facing up until the bearing is fully seated using the special tools.

### TOOLS:

Driver	07749-0010000
Attachment, 52 x 55 mm	07746-0010400
Pilot, 20 mm	07746-0040500

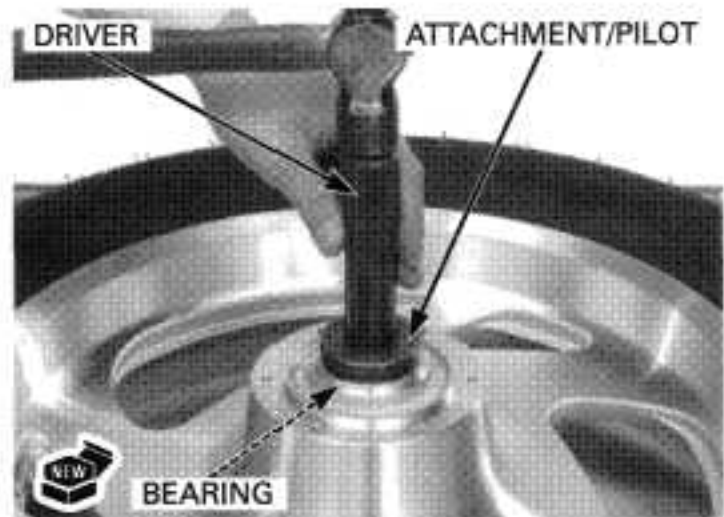

Install the brake discs onto both sides of the wheel hub with their marked side facing out. Install new brake disc bolts and tighten them in a crisscross pattern in two to three steps.

**TORQUE: 20 N·m (2.0 kgf·m, 14 lbf·ft)**

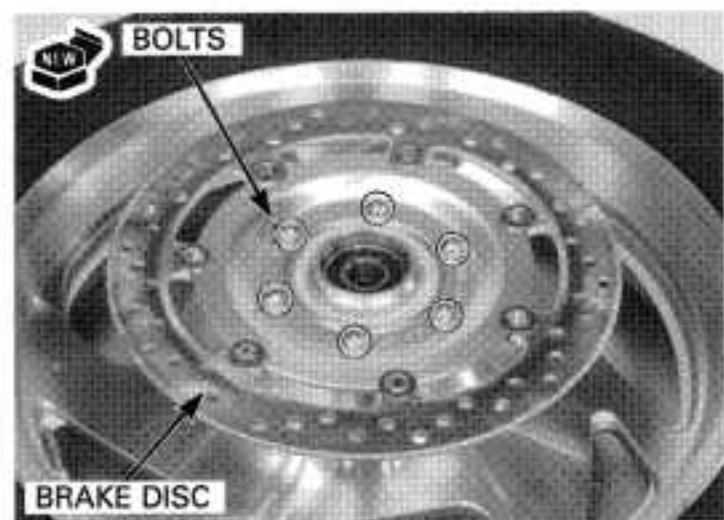

### WHEEL BALANCE

- The wheel balance must be checked when the tire is remounted.
- For optimum balance, the tire balance mark (a paint dot on the side wall) must be located next to the mark on the wheel.
- Mount the tire with the arrow mark facing in the normal rotating direction.

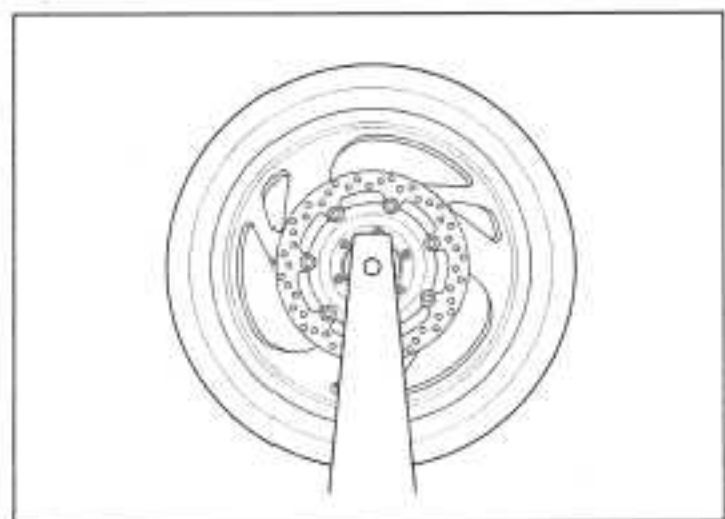

*Wheel balance directly affects the stability, handling and overall safety of the motorcycle. Carefully check wheel balance before reinstalling the wheel.*

Mount the wheel, tire and brake disc assembly on an inspection stand.

Spin the wheel, allow it to stop, and mark the lowest (heaviest) part of the wheel with chalk.

Do this two or three times to verify the heaviest area. If the wheel is balanced, it will not stop consistently in the same position.

To balance the wheel, install balance weights on the lightest side of rim, the side opposite the chalk marks. Add just enough weight so the wheel will no longer stop in the same position when it is spun.

Do not add more than 60 g (2.1 oz) to the wheel.

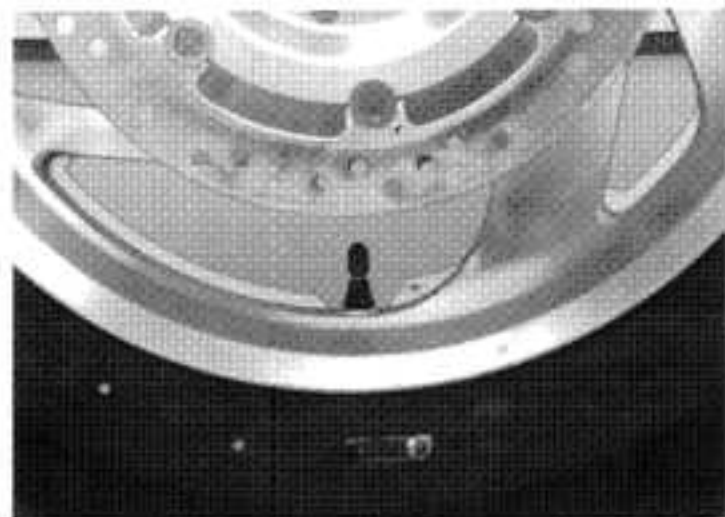

*Do not get grease on the brake disc or stopping power will be reduced.*

Apply grease to new dust seal lips and install the dust seals into both sides of the wheel until they are fully seated.

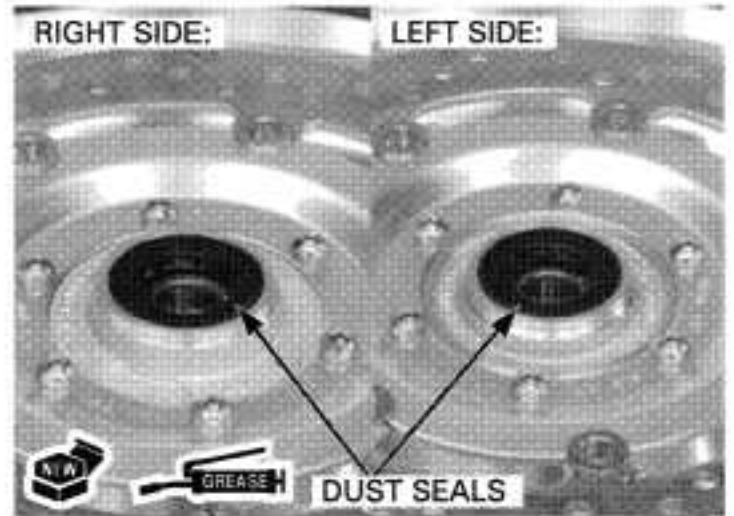

### INSTALLATION

Install the right side collar into the right wheel hub.

Install the left side collar into the left wheel hub.

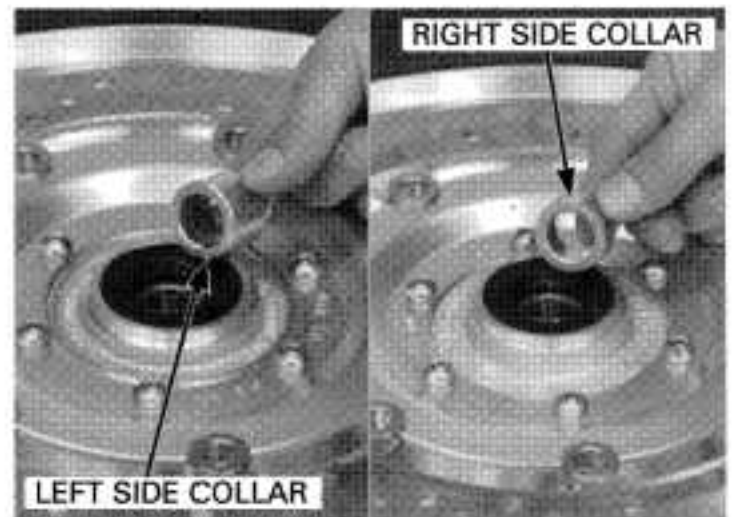

Place the front wheel between the fork legs. Insert the front axle from the left side until it is fully seated.

Install and tighten the axle bolt to the specified torque.

**TORQUE: 90 N·m (9.2 kgf·m, 67 lbf·ft)**

Tighten the right axle pinch bolts to the specified torque.

**TORQUE: 22 N·m (2.2 kgf·m, 16 lbf·ft)**

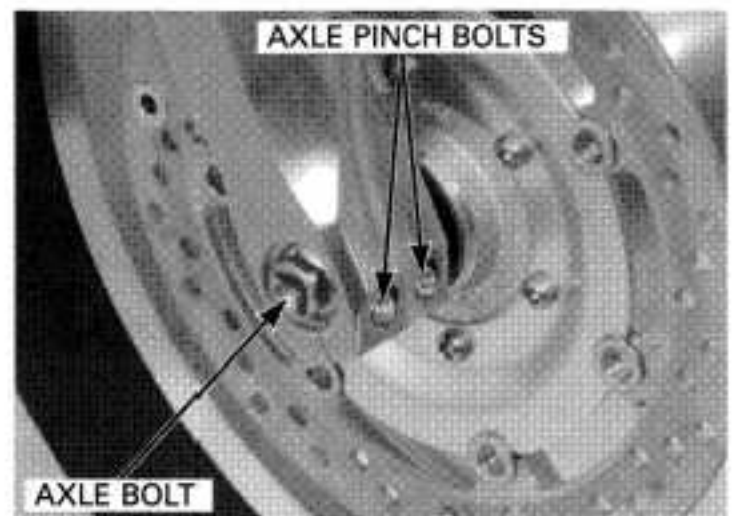

Install new brake caliper mounting bolts and tighten them to the specified torque.

**TORQUE: 30 N·m (3.1 kgf·m, 22 lbf·ft)**

Install the brake hose clamps and tighten the bolts securely.

Install the front brake pads (page 15-10).

With the front brake applied, pump the fork up and down several times to seat the axle and check brake operation by applying the brake lever and pedal.

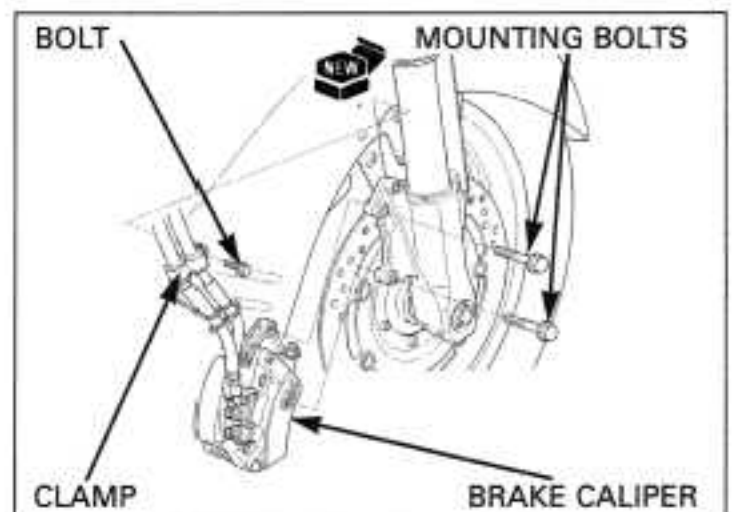



## FRONT WHEEL/SUSPENSION/STEERING

Tighten the left axle pinch bolts to the specified torque.

**TORQUE: 22 N·m (2.2 kgf·m, 16 lbf·ft)**

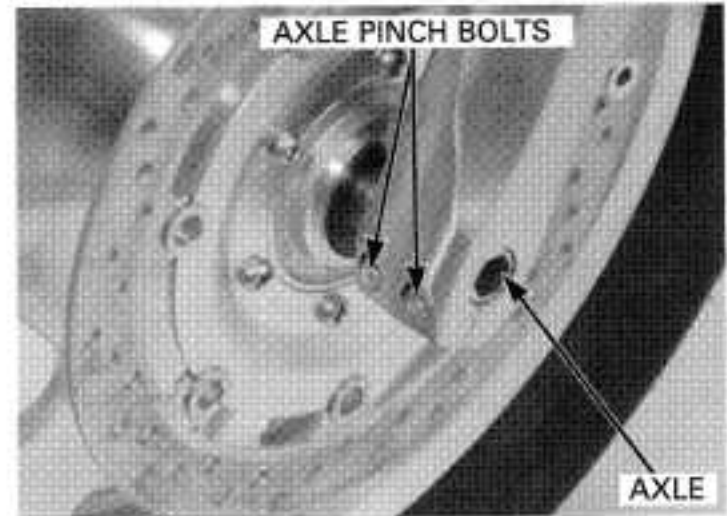

Install the bolt caps to the axle pinch bolts securely.

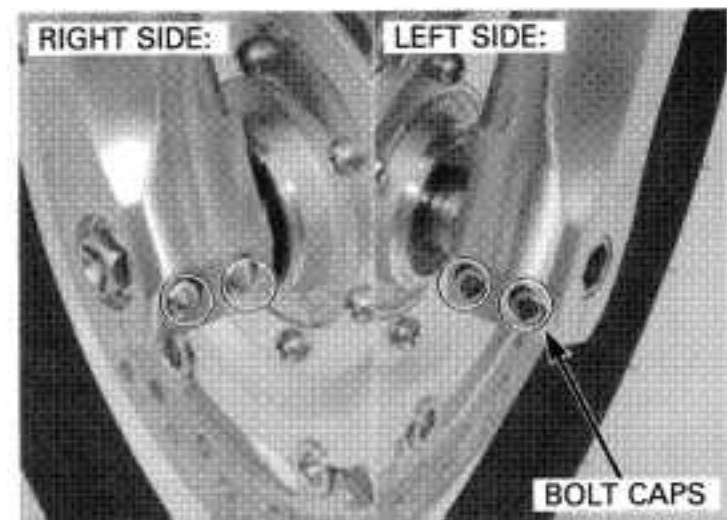

Check the clearance between the brake disc and caliper bracket on each side after installation. The clearance should be at least 0.7 mm (0.03 in).

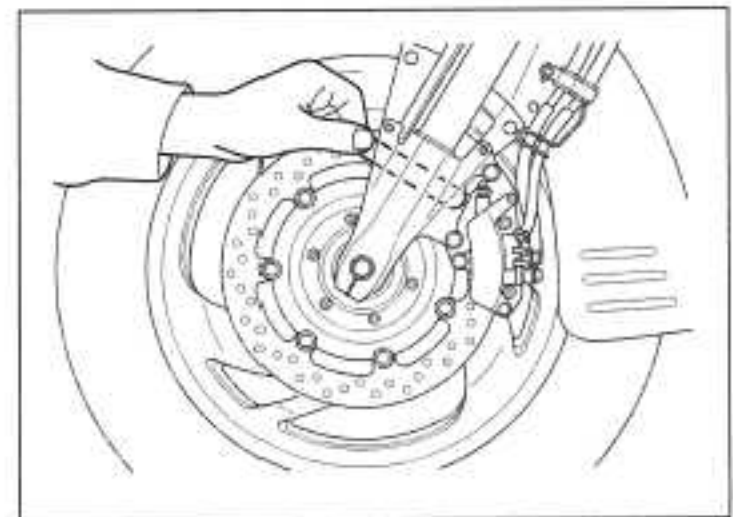

## FORK

### REMOVAL

Remove the front wheel (page 13-8).

Remove the socket bolts and front fender.  
Remove the socket bolts and fork protectors.

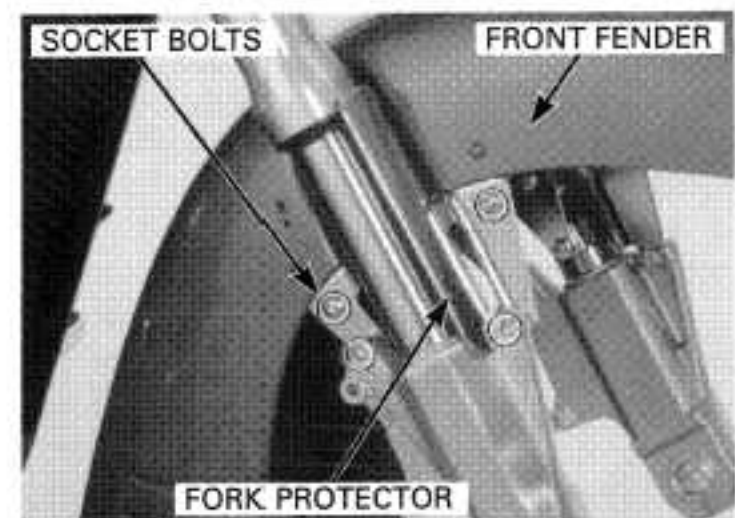



Remove the bolts, holder and turn signal assemblies (page 19-5).

Loosen the fork top bridge pinch bolt. When the fork is ready to be disassembled, loosen the fork cap, but do not remove it yet.

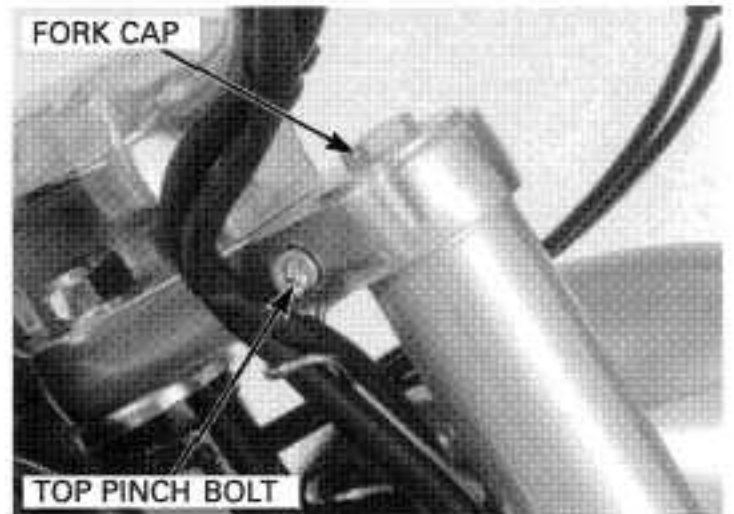

Loosen the bottom bridge pinch bolts and remove the fork pipe from the top bridge and steering stem.

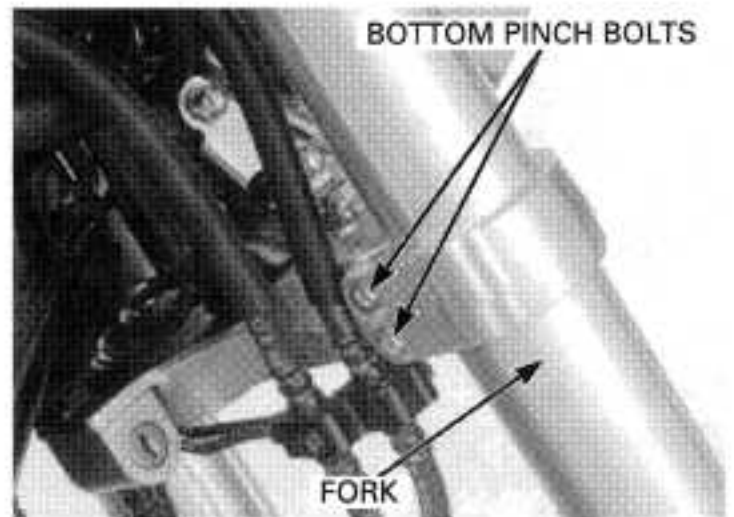

### RIGHT FORK DISASSEMBLY

*Be careful not to scratch the outer pipe or damage the dust seal.*

Remove the fork cap from the outer pipe. Slide outer pipe down onto the axle holder.

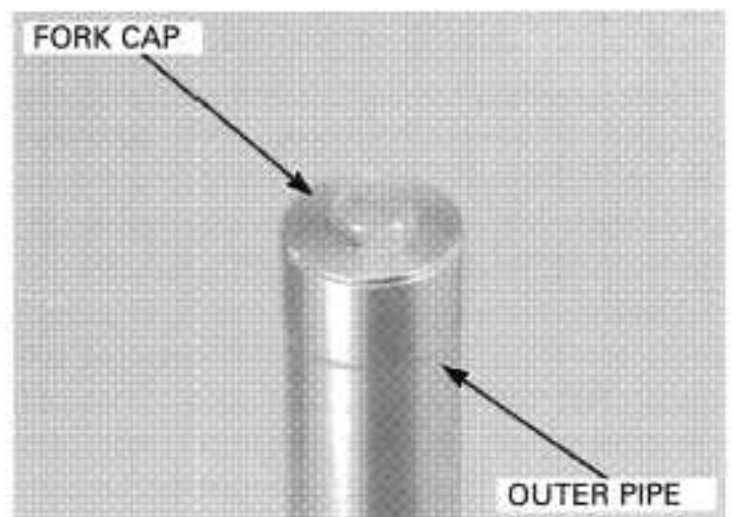

Hold the damper rod lock nut with a spanner, then loosen and remove the fork cap from the damper rod.

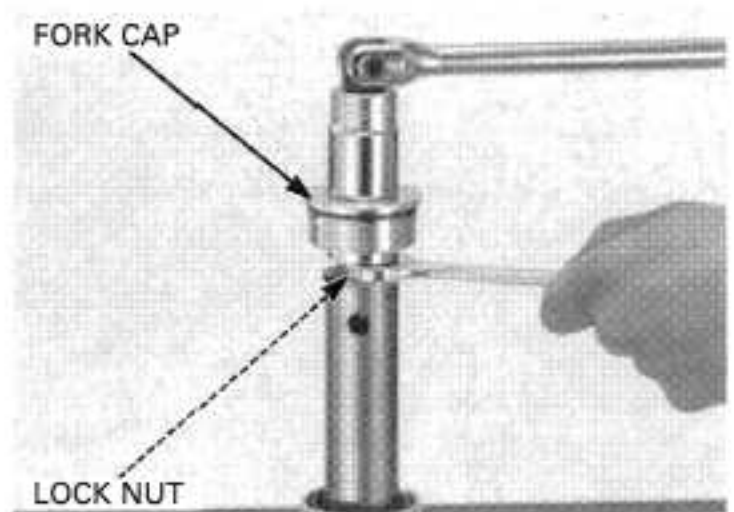

## FRONT WHEEL/SUSPENSION/STEERING

*The spring seat stopper and spring collar are under spring pressure. Use care when removing them and wear eye and face protection.*

Loosen the lock nut as shown. While pushing down the spring collar, remove the spring seat stopper.

Remove the spring collar.

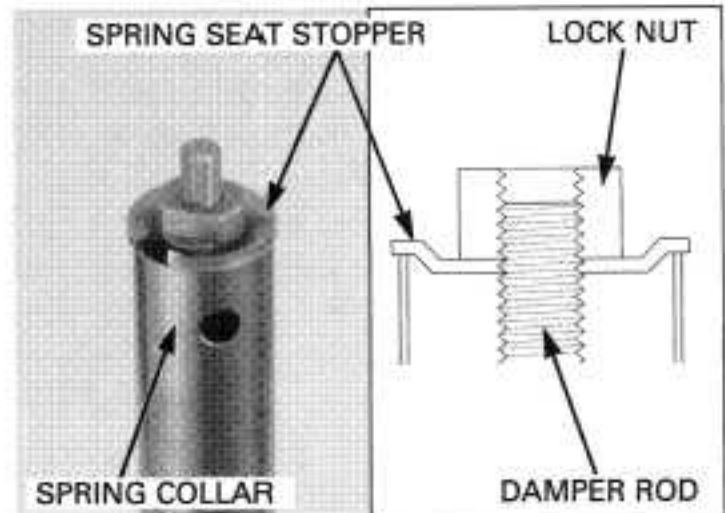

Remove the fork spring.

Pour out the fork fluid by pumping the outer pipe up and down several times.

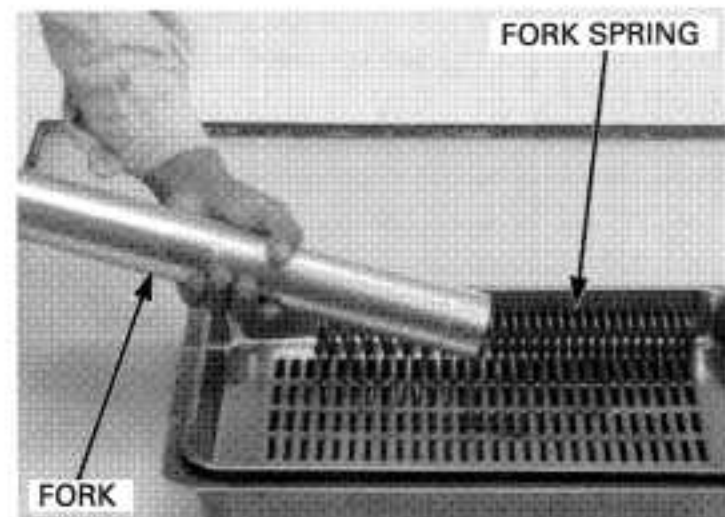

Pour out the remaining fork fluid by pumping the fork damper rod up and down several times.

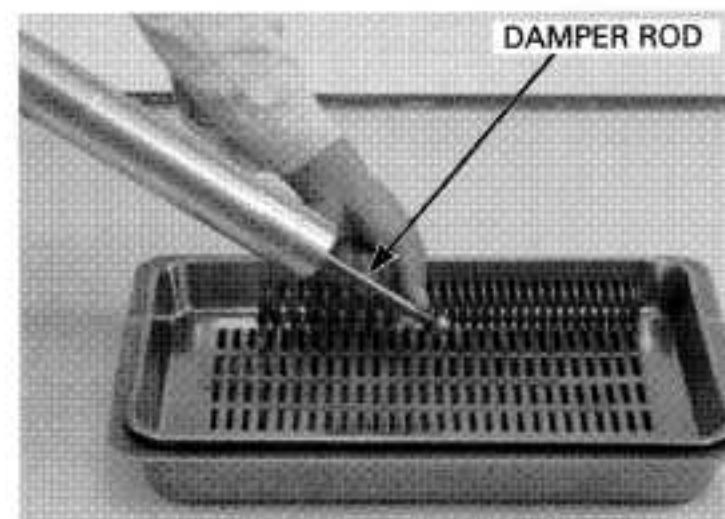

Hold the fork pipe in a vise with soft jaws or shop towel.

Remove the fork socket bolt and sealing washer with a hex wrench.

*If the fork damper turns with the socket bolt, temporarily install the spring collar, spring seat stopper and fork cap.*

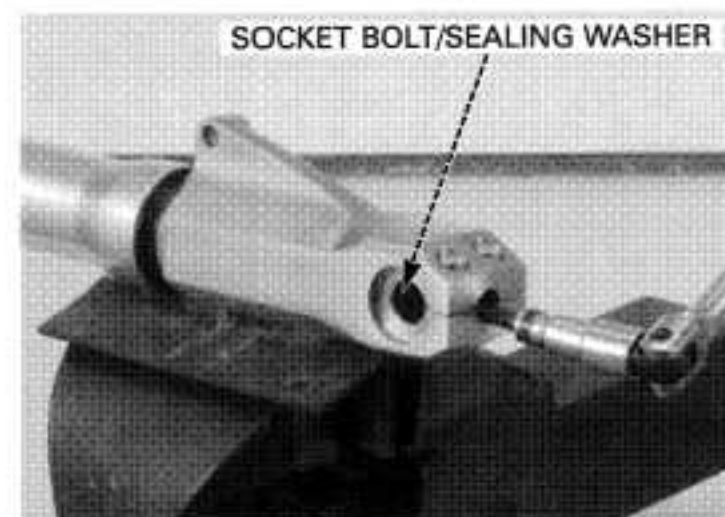

Remove the fork damper and centering plate.

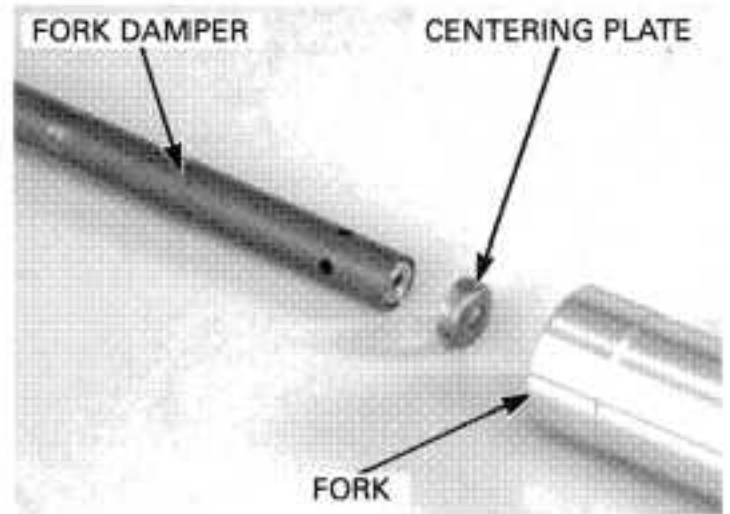

Remove the dust seal.

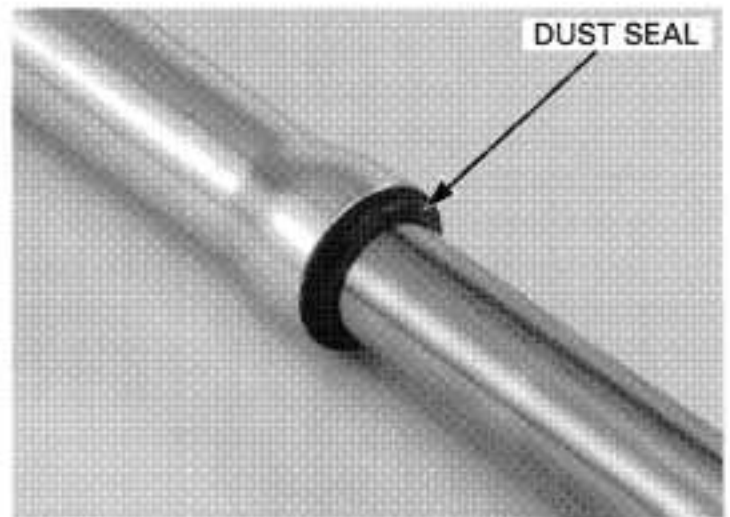

*Do not scratch  
the outer pipe  
sliding surface.*

Remove the stopper ring.

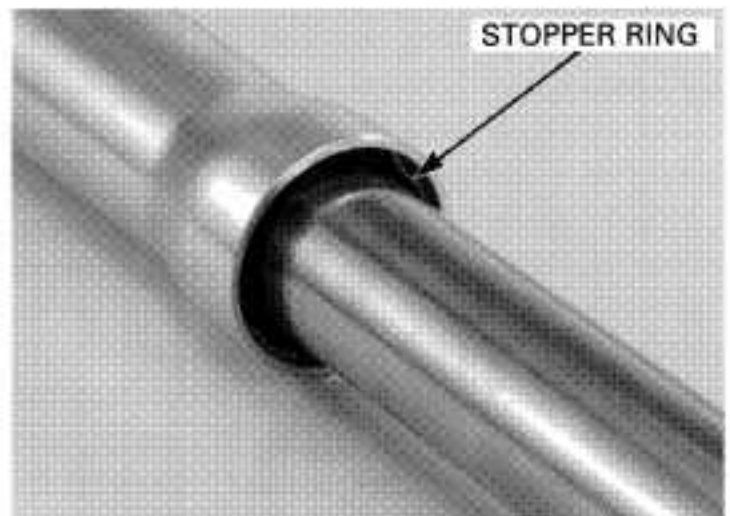

Pull the fork slider out until the slider bushing is felt. Then pull the fork slider in and out, tapping the bushing lightly until the fork slider separates from the outer pipe. The slider bushing will be forced out by the fork pipe bushing.

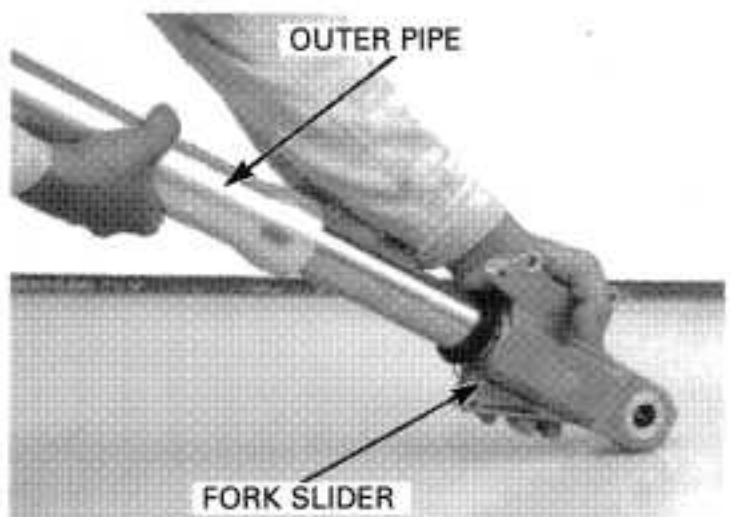

## FRONT WHEEL/SUSPENSION/STEERING

Carefully remove the slider bushing by prying the slot with a screwdriver until the bushing can be pulled off by hand.

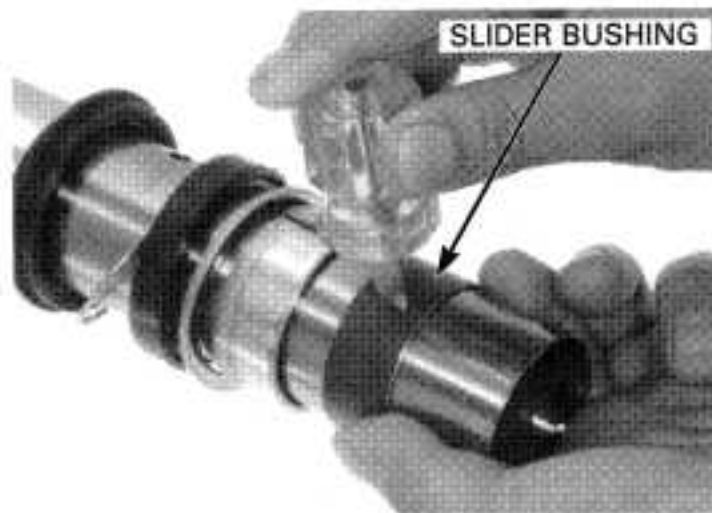

Remove the guide bushing, back-up ring, oil seal, stopper ring and dust seal from the fork slider.

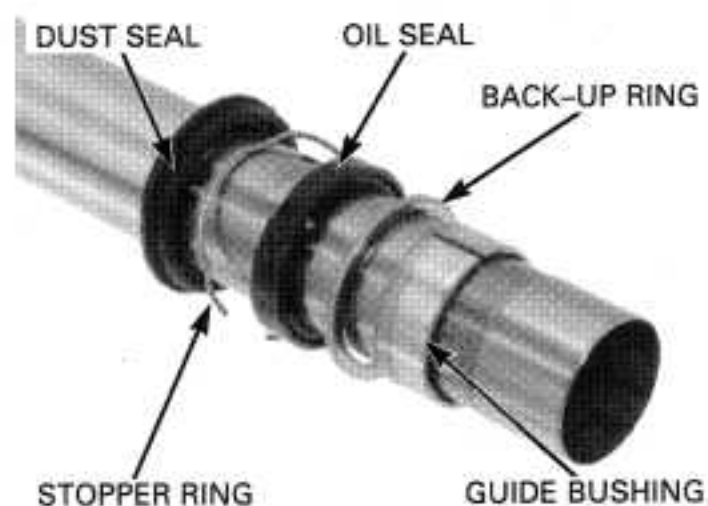

### LEFT FORK DISASSEMBLY

*Be careful not to scratch the outer pipe or damage the dust seal.*

Remove the fork cap from the outer pipe.  
Slide the outer pipe down onto the axle holder.

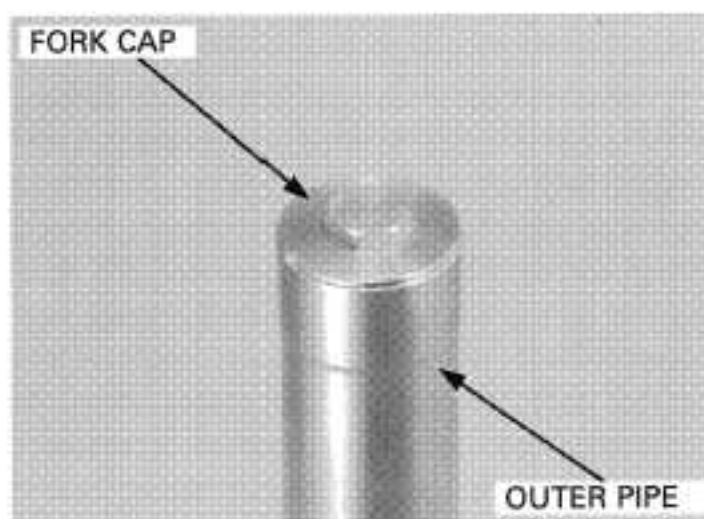

Pull down the rubber stopper.

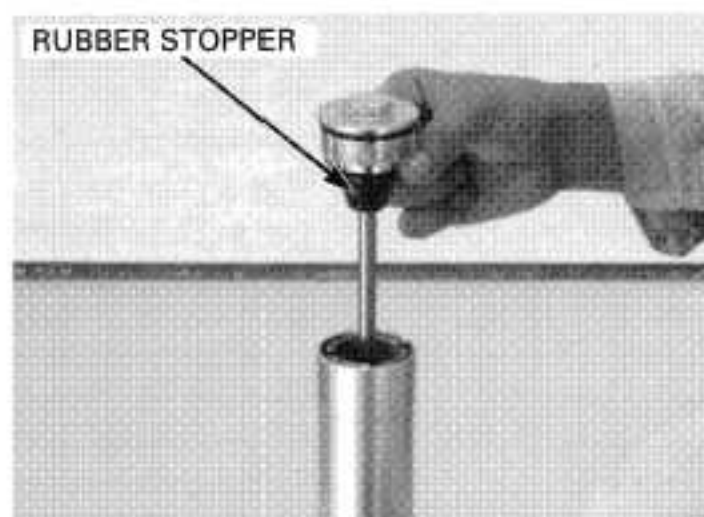



Hold the rod lock nut with a spanner, then loosen and remove the fork cap from the rod.  
Remove the rubber stopper from the rod.

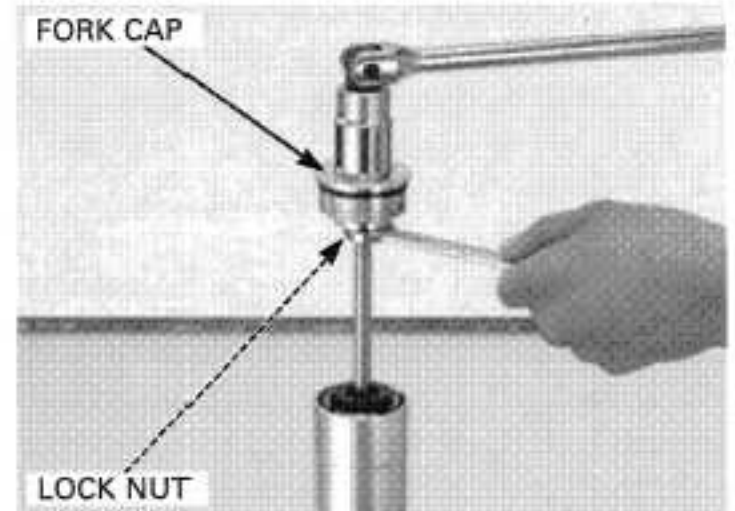

*The inner fork bolt is under spring pressure. Use care when removing them and wear eye and face protection.*

Pull down the outer pipe so the inner fork bolt is visible.  
Remove the inner fork bolt.

**TOOL:**  
Lock nut wrench, 36 x 44 mm 07VMA-MZ0010A

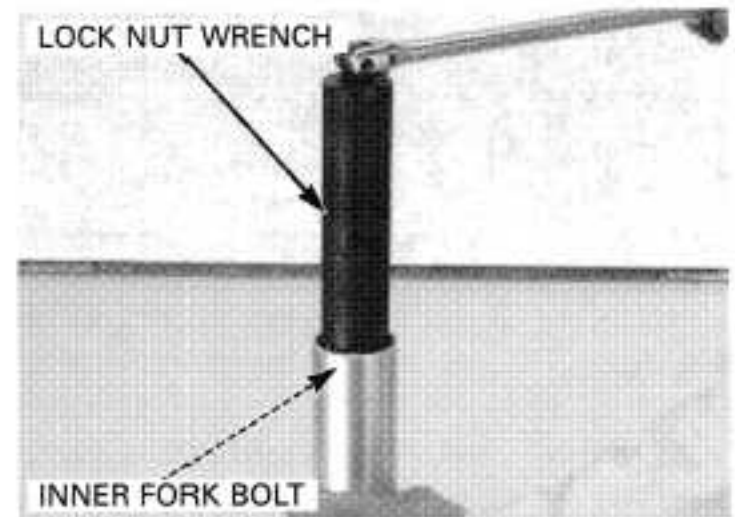

Remove the rebound rod assembly.

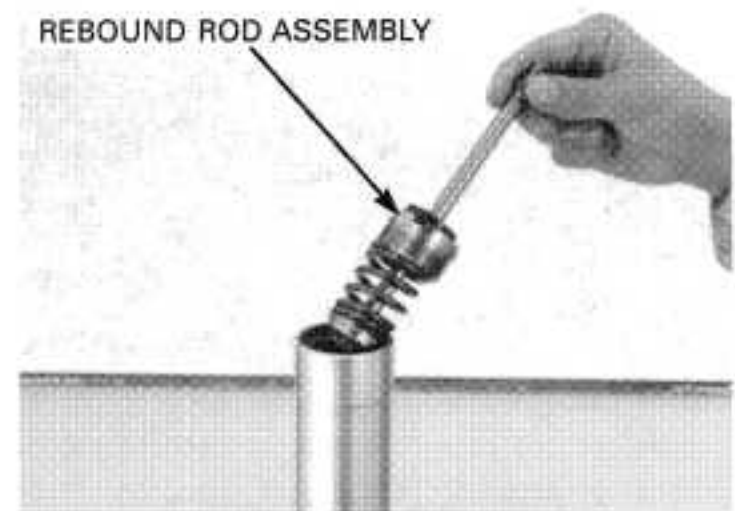

Remove the spring collar, fork spring joint plate and fork spring.

Pour out the fork fluid by pumping the outer pipe up and down several times.

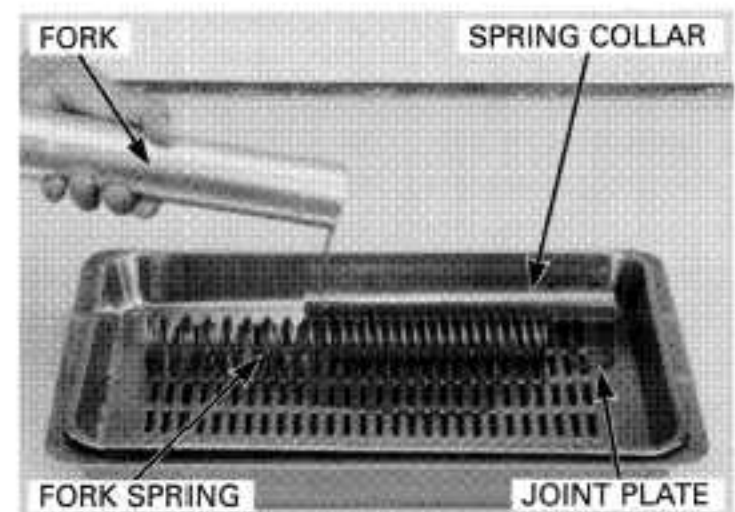



## FRONT WHEEL/SUSPENSION/STEERING

Remove the dust seal.

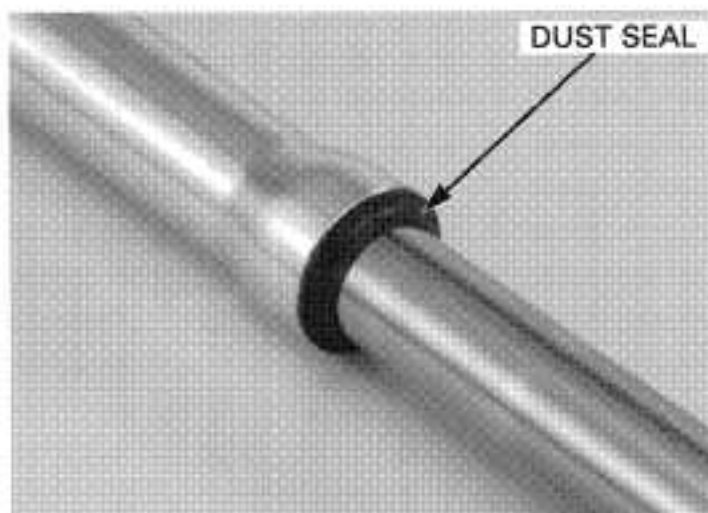

*Do not scratch  
the outer pipe  
sliding surface.*

Remove the stopper ring.

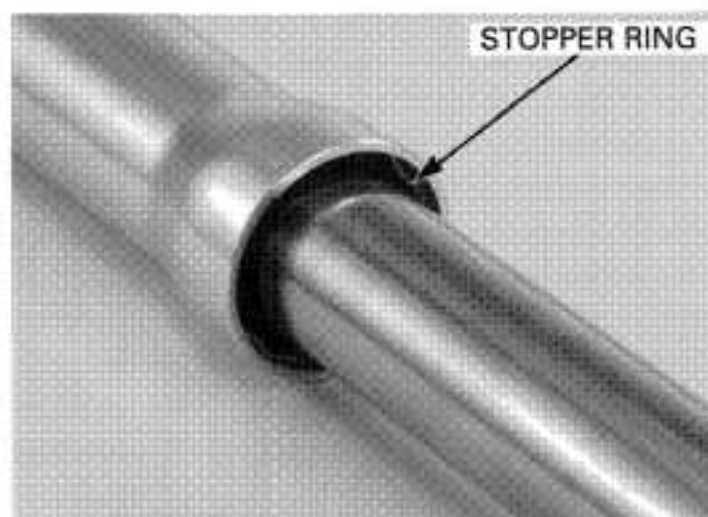

Pull the fork slider out until the slider bushing is felt. Then pull the fork slider in and out, tapping the bushing lightly until the fork slider separates from the outer pipe. The slider bushing will be forced out by the fork pipe bushing.

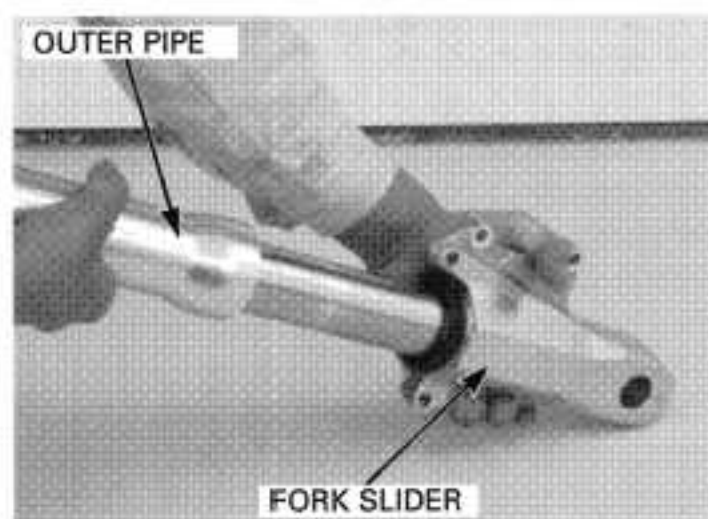

Carefully remove the slider bushing by prying the slot with a screwdriver until the bushing can be pulled off by hand.

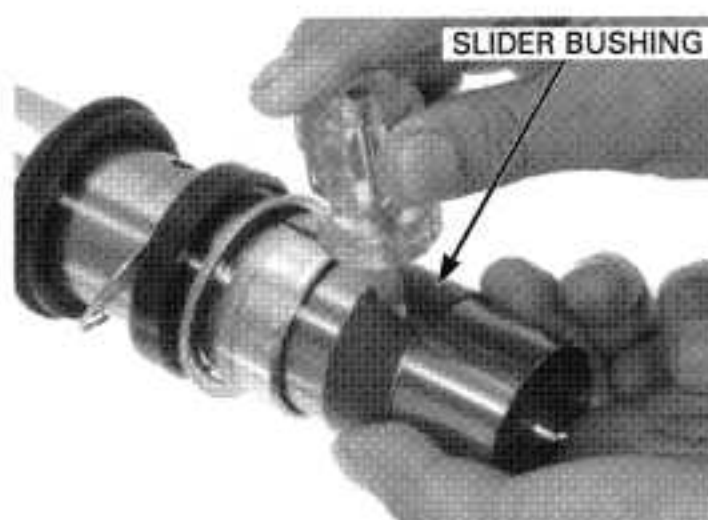

Remove the guide bushing, back-up ring, oil seal, stopper ring and dust seal from the fork slider.

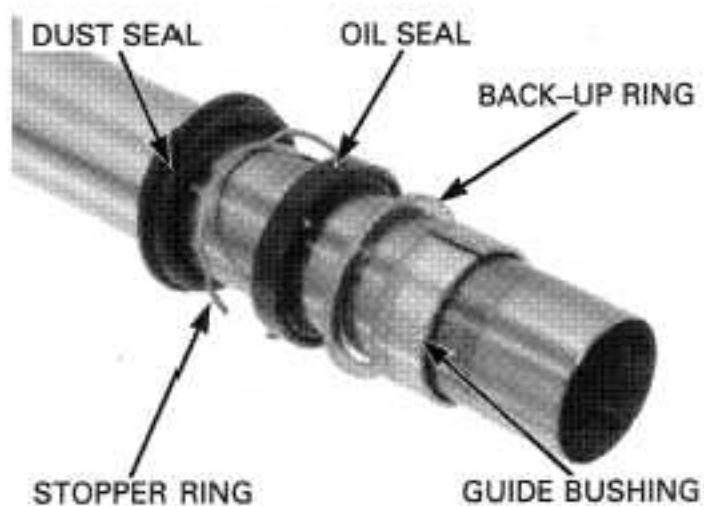

### INSPECTION

#### FORK SPRING

Check the fork spring for wear or damage.  
Measure the fork spring free length.

**SERVICE LIMITS:** Right: 341.4 mm (13.44 in)  
Left: 341.4 mm (13.44 in)

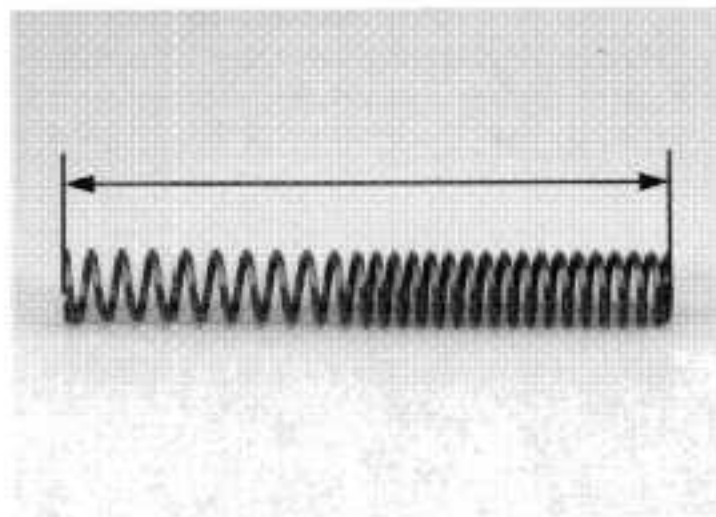

#### SPRING COLLAR

Check the spring collar for score marks, scratches, or excessive or abnormal wear.

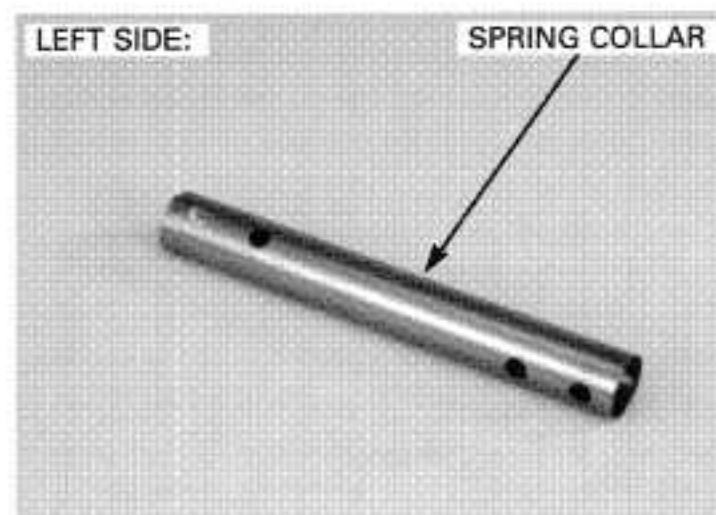
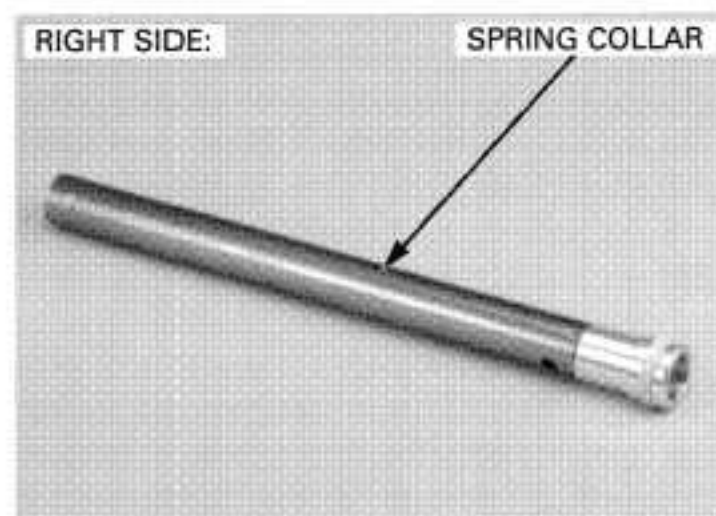

## FRONT WHEEL/SUSPENSION/STEERING

### OUTER PIPE/SLIDER

Check the outer pipe and slider for score marks, scratches, or excessive or abnormal wear.

Replace any components which are worn or damaged.

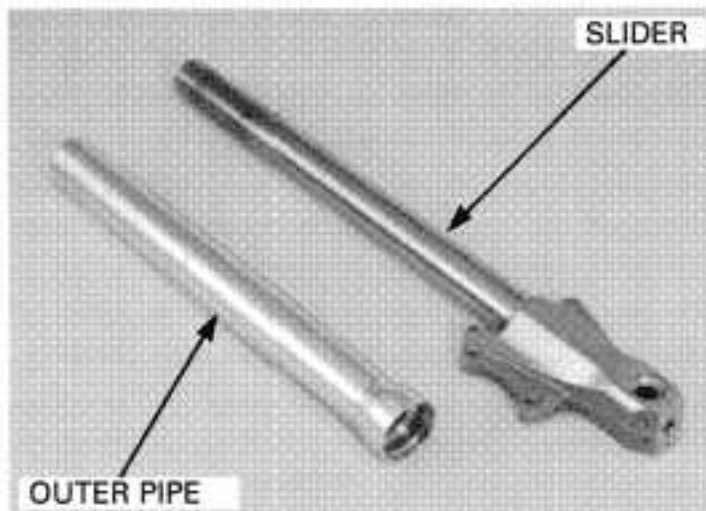

### FORK DAMPER (RIGHT SIDE)

Check the fork damper and centering plate for damage.

Replace the fork damper assembly, if necessary.

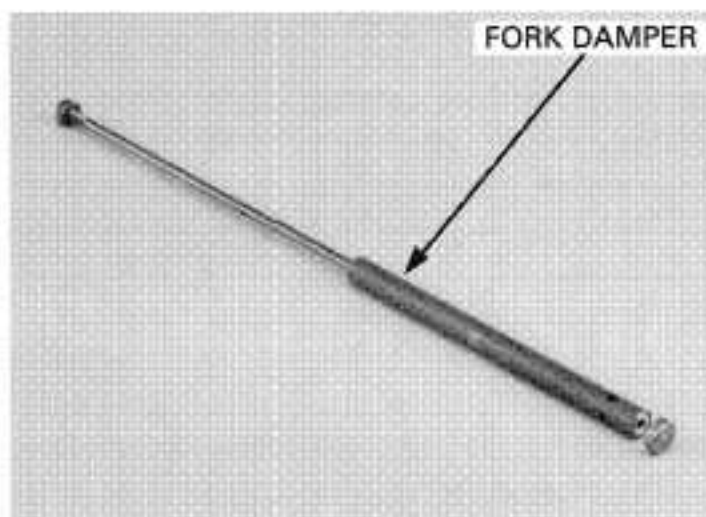

### REBOUND SPRING (LEFT SIDE)

Check the rebound spring for wear or damage.

Replace the rebound spring, if necessary.

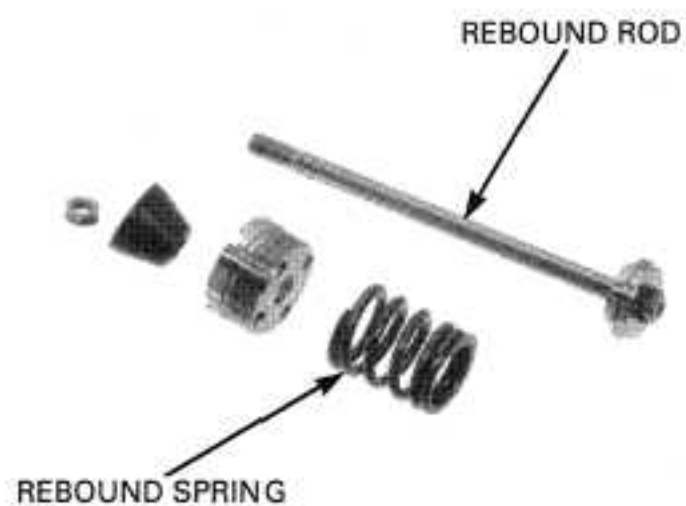

### FORK SLIDER

Set the fork slider in V-blocks and measure the fork slider runout with a dial indicator.

Actual runout is 1/2 the total indicator reading.

**SERVICE LIMIT: 0.20 mm (0.008 in)**

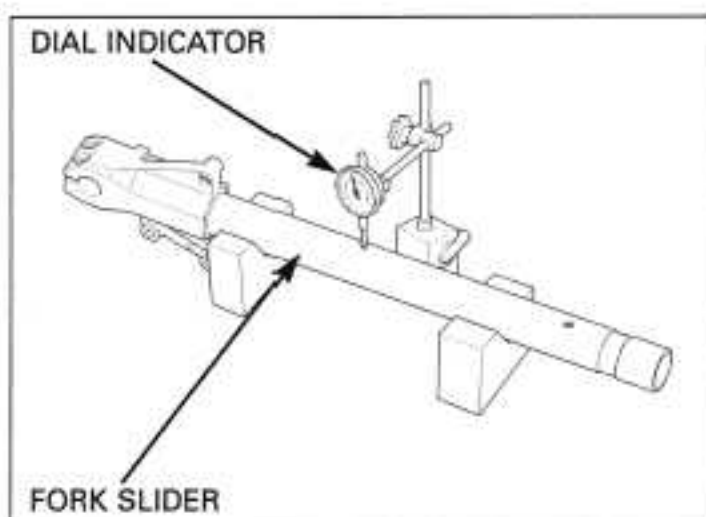

**SLIDER BUSHING/GUIDE BUSHING/BACK-UP RING**

Visually inspect the slider and guide bushings. Replace the bushings if there is excessive scoring or scratching, or if the teflon is worn so that the copper surface appears on more 3/4 of the entire surface.

Check the back-up ring; replace it if there is any distortion at the points shown.

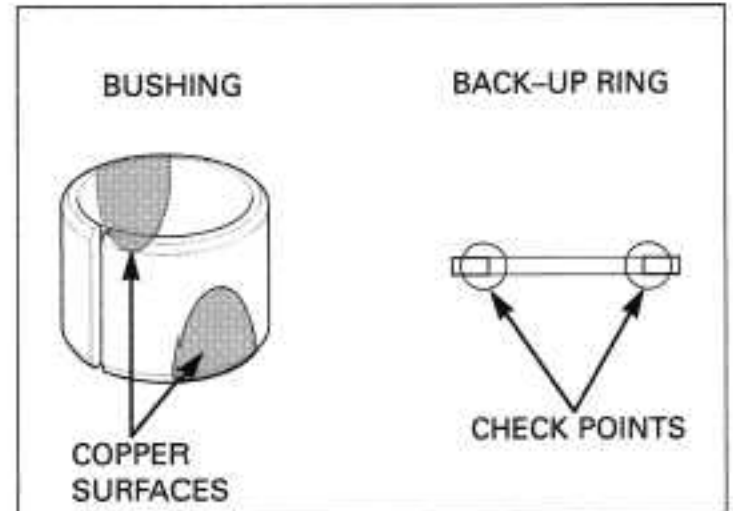

**RIGHT FORK ASSEMBLY**

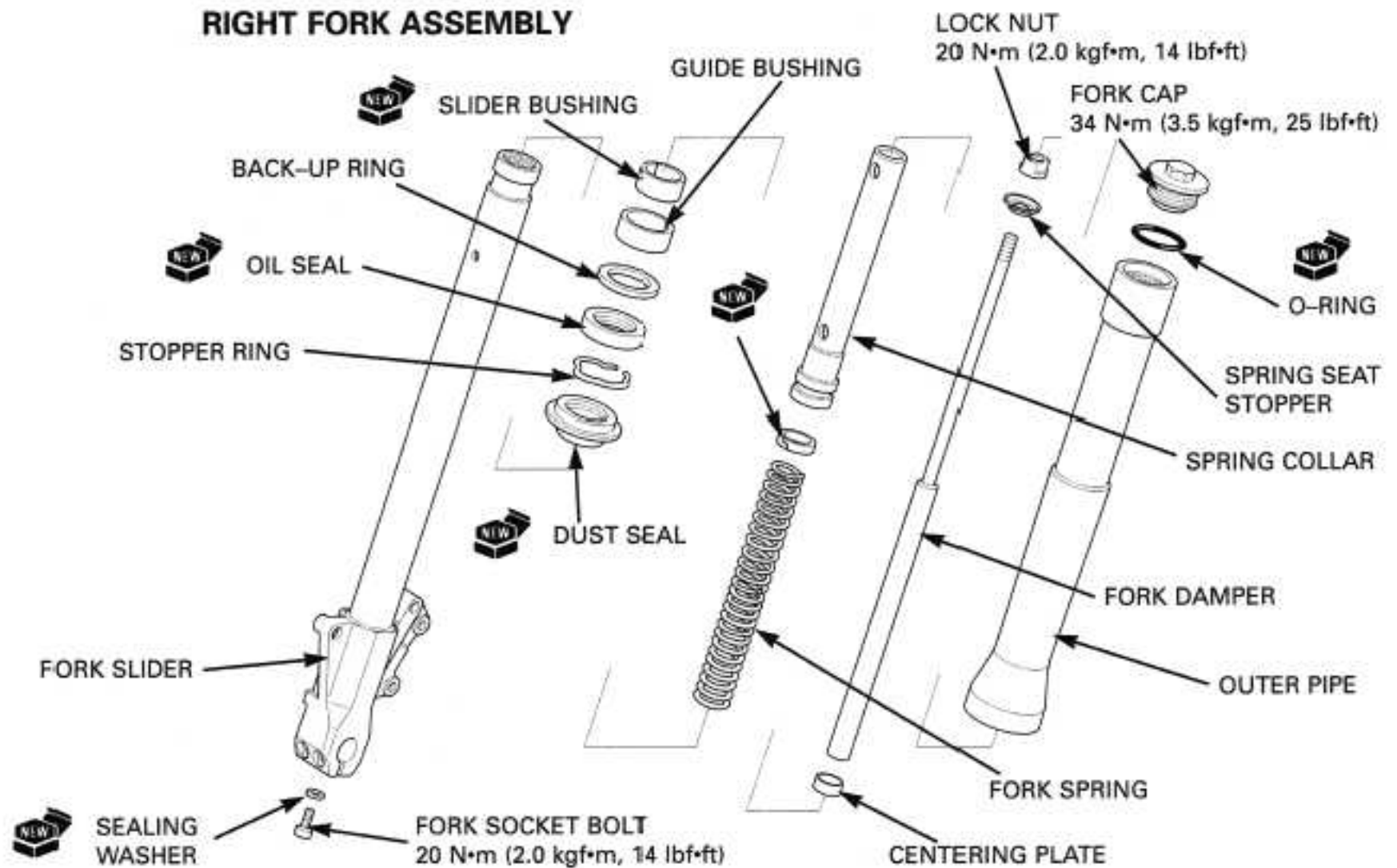

Before assembly, wash all parts with a high flash or non-flammable solvent and wipe them dry.

Wrap the end of the slider with tape.  
Coat the oil seal lips with the recommended fork fluid.

*Install the oil seal with its marked side facing up.*

Install new dust seal, stopper ring and new oil seal.

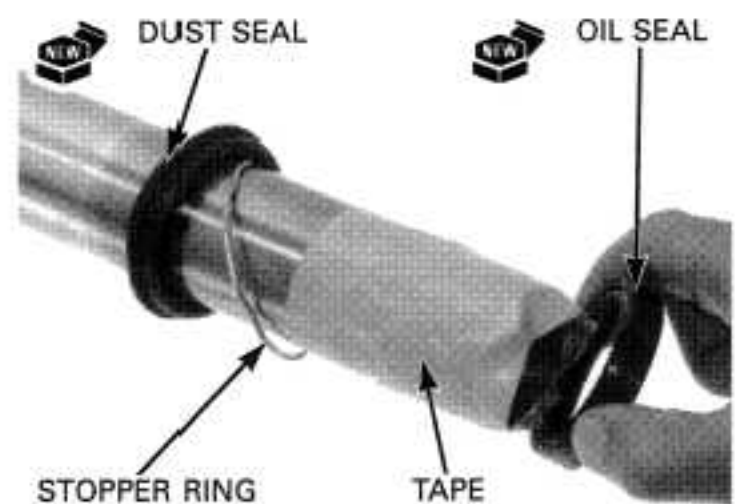

## FRONT WHEEL/SUSPENSION/STEERING

Install the back-up ring, guide bushing and new slider bushing.

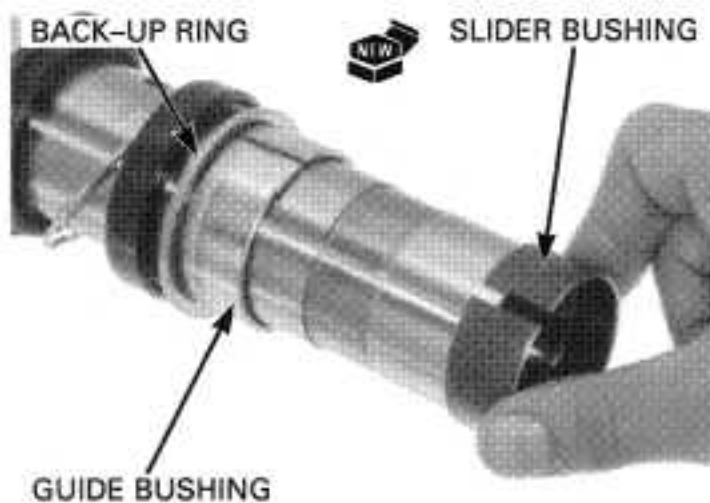

Apply the recommended fork fluid to the slider bushing and guide bushing.  
Install the fork slider into the outer pipe.

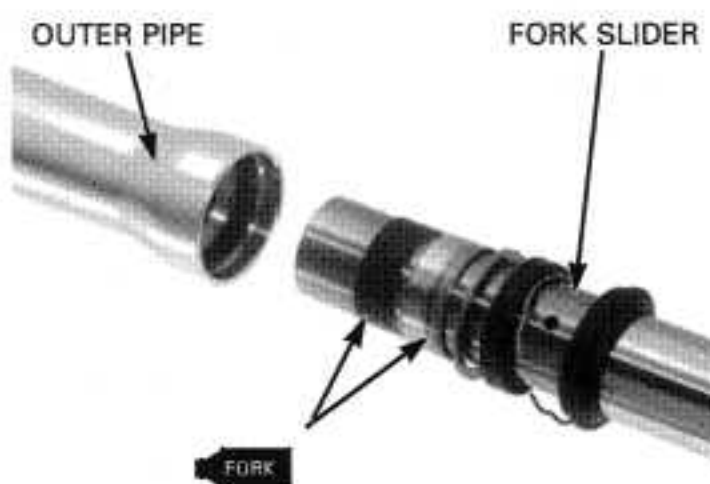

Drive the oil seal in using the special tools.

**TOOL:**  
Fork seal driver, 45 mm      07KMD-KZ30100

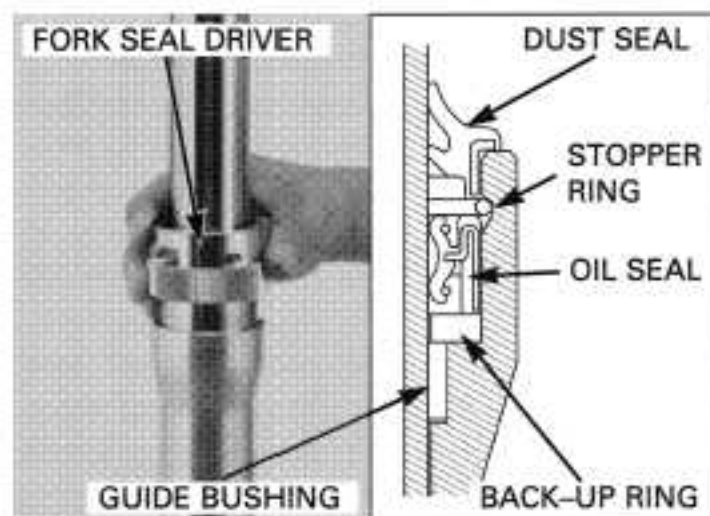

Install the stopper ring into the groove in the outer pipe.

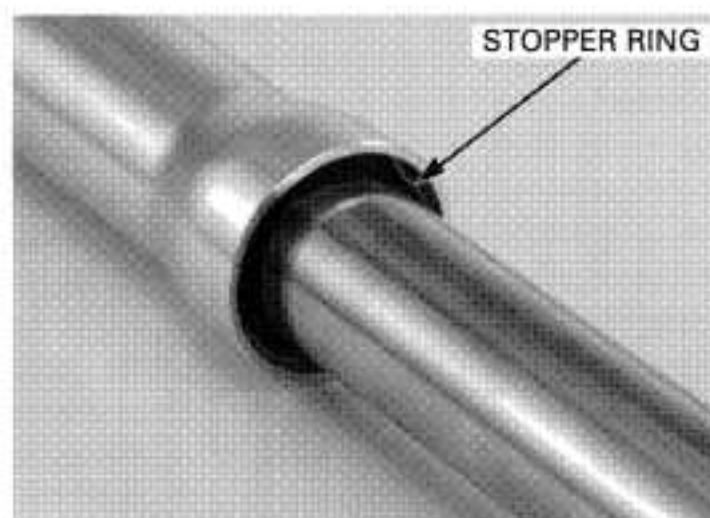



Install the dust seal.

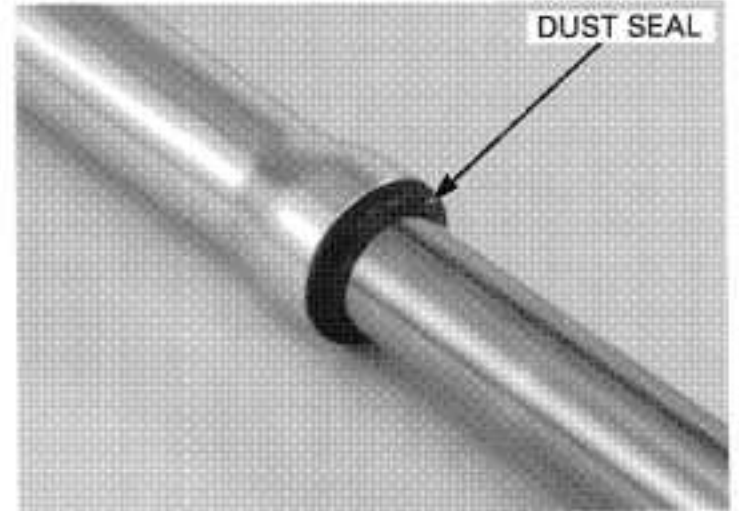

Install the centering plate to the fork damper.  
Install the fork damper into the fork.

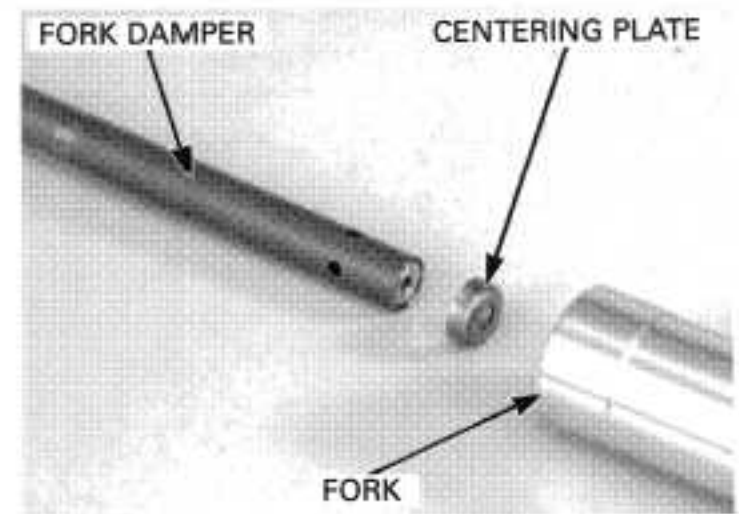

Hold the fork slider in a vise with soft jaws or a shop towel.  
Clean and apply a locking agent to the fork socket bolt threads.  
Install the fork socket bolt with a new sealing washer.

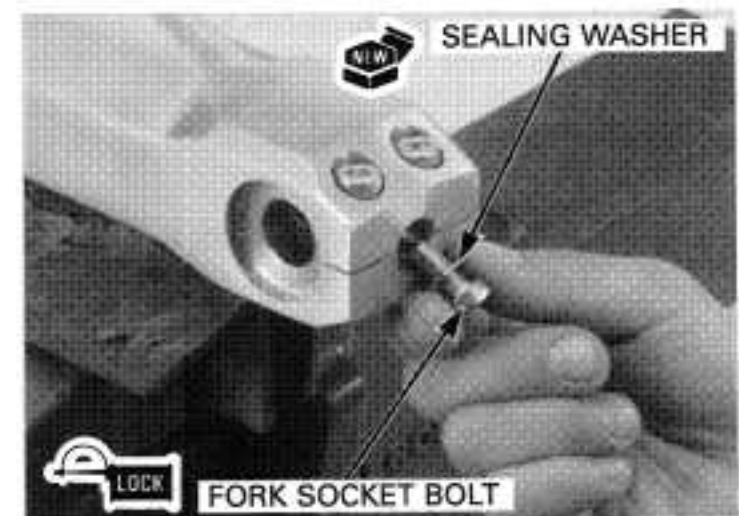

*If the fork damper turns with the socket bolt, temporarily install the spring collar, spring seat stopper and fork cap.*

Tighten the fork socket bolt to the specified torque.

**TORQUE: 20 N·m (2.0 kgf·m, 14 lbf·ft)**



## FRONT WHEEL/SUSPENSION/STEERING

Pour the specified amount of the recommended fork fluid into the fork.

**RECOMMENDED FORK FLUID:**  
Pro Honda Suspension Fluid SS-8

**FORK FLUID CAPACITY:**  
 $696 \pm 2.5 \text{ cm}^3$  (23.5  $\pm$  0.08 US oz,  
24.5  $\pm$  0.09 Imp oz)

Pump the damper rod several times.

Measure the oil level from the top of the outer pipe while compressing the outer pipe all the way after stroking the outer pipe slowly more than 5 times and the damper rod more than 10 times.

**FORK FLUID LEVEL: 102 mm (4.1 in)**

Wipe off any excessive fluid from the fork spring and collar.

Install the fork spring with its tapered end facing up.

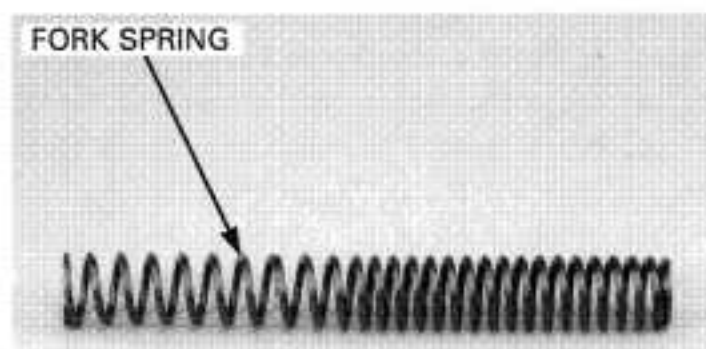
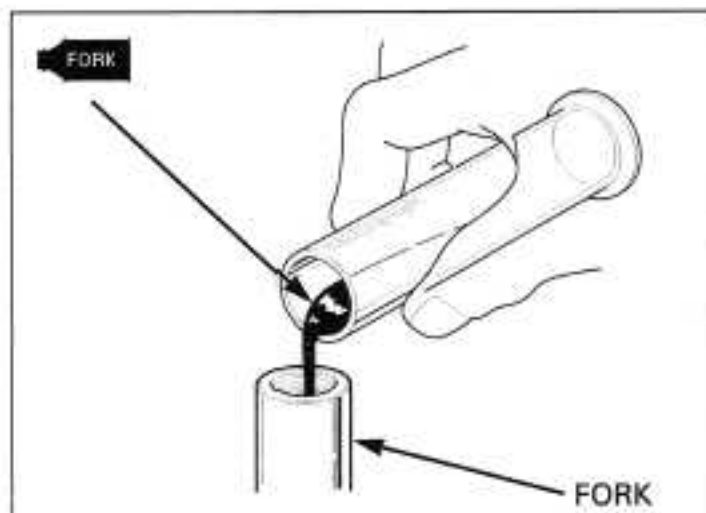

Install the lock nut to the damper rod.  
Attach a 600 mm (2 feet) length of mechanic's wire to the lock nut on the damper rod.

Pull the outer pipe up and install the spring collar.

While pushing down the spring collar, install the spring seat stopper.

Remove the mechanic's wire from the damper rod.

Screw the damper rod lock nut fully by hand.

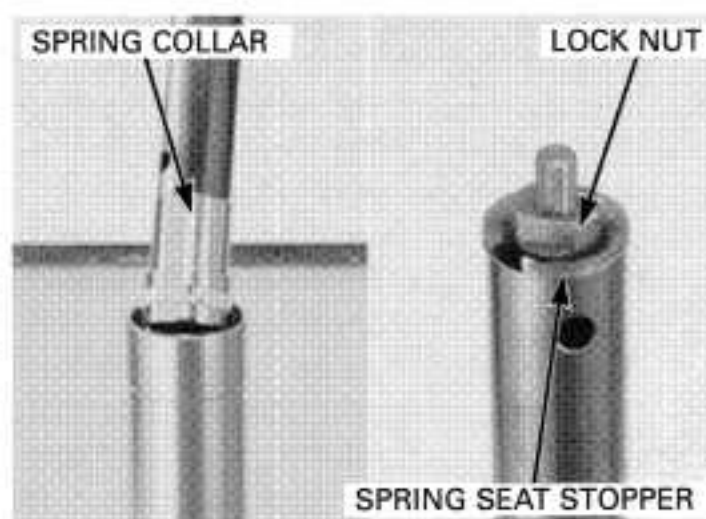

Apply the recommended fork fluid to the new O-ring and install it onto the fork cap.  
Install the fork cap to the damper rod.

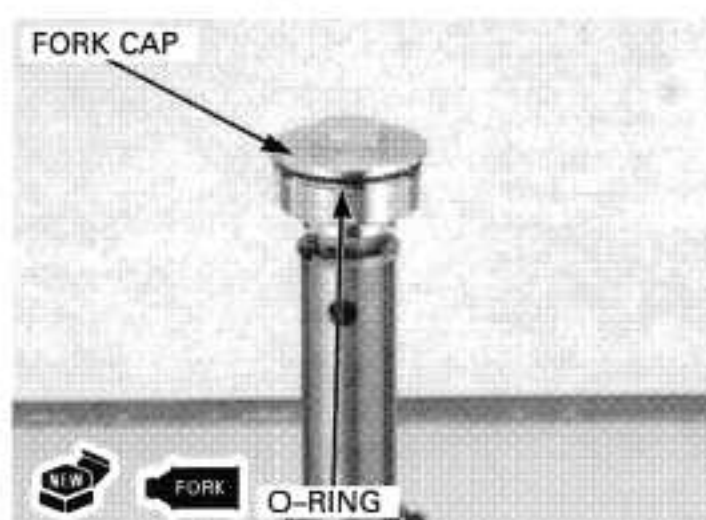

Hold the fork cap and tighten the lock nut to the specified torque.

**TORQUE: 20 N·m (2.0 kgf·m, 14 lbf·ft)**

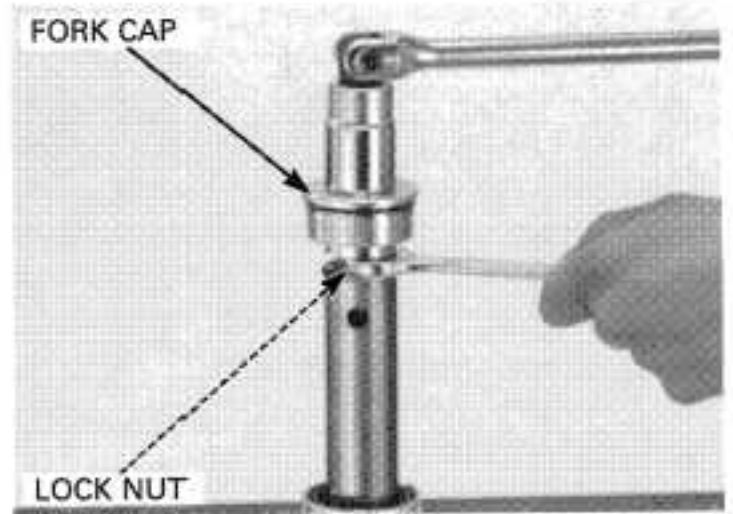

*Tighten the fork cap after installing the fork into the top bridge.*

Screw the fork cap into the outer pipe.

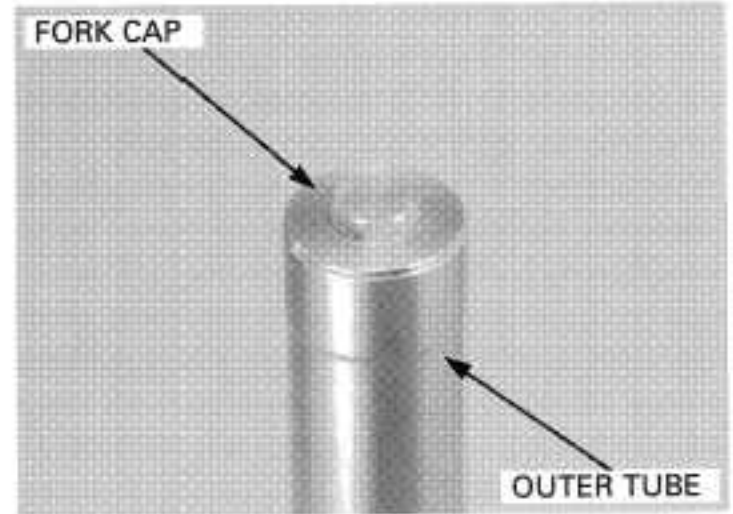

**LEFT FORK ASSEMBLY**

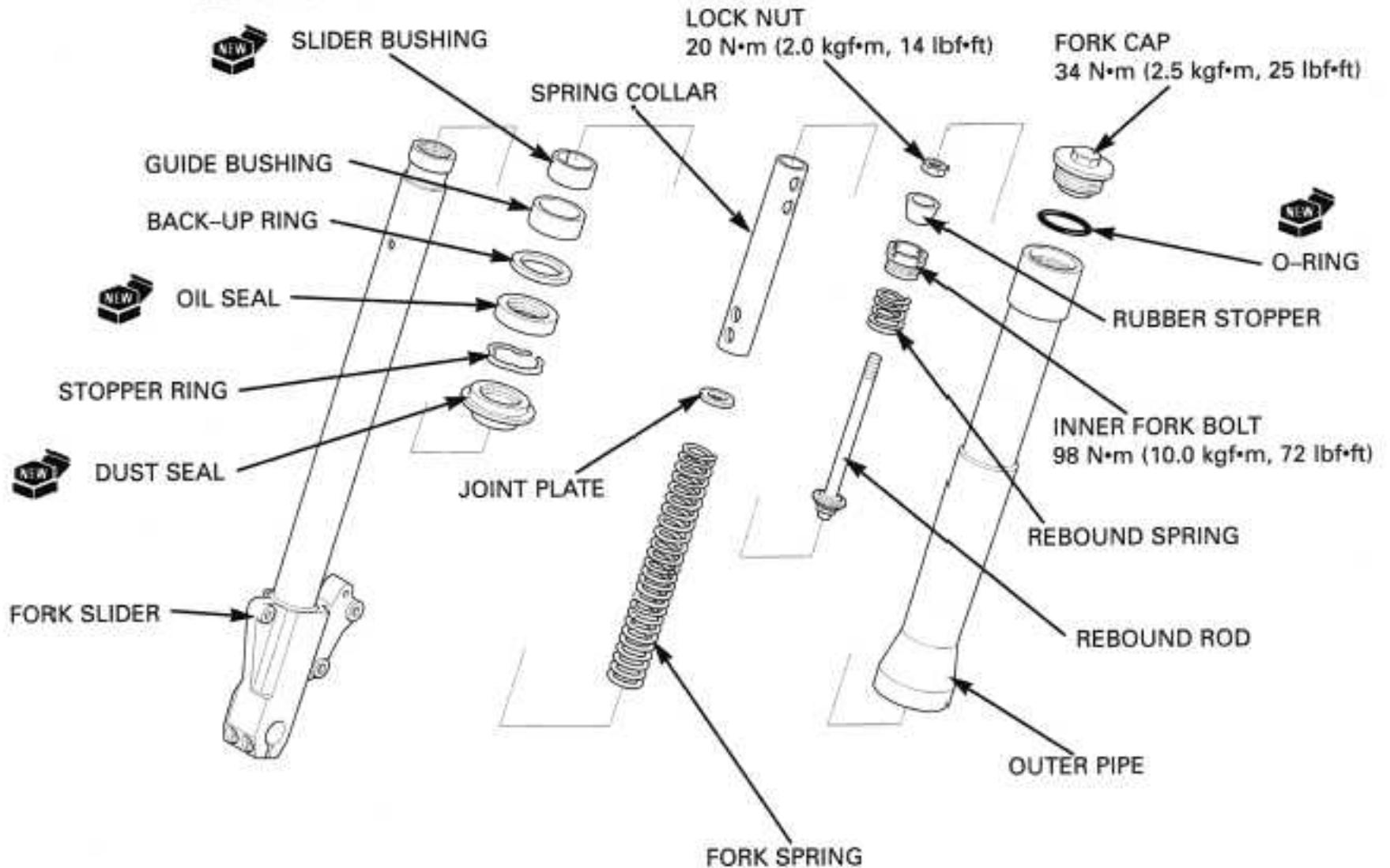

## FRONT WHEEL/SUSPENSION/STEERING

Before assembly, wash all parts with a high flash or non-flammable solvent and wipe them dry.

Wrap the end of the slider with tape.  
Coat the oil seal lips with the recommended fork fluid.

*Install the oil seal with its marked side facing up.*

Install a new dust seal, stopper ring and new oil seal.

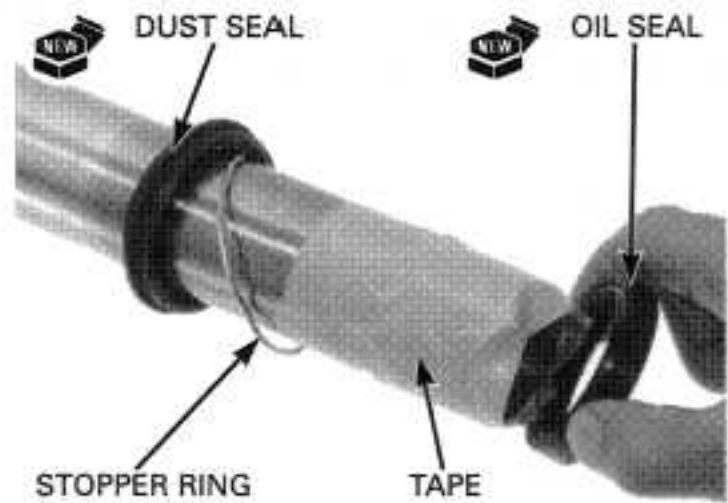

Install the back-up ring, guide bushing and new slider bushing.

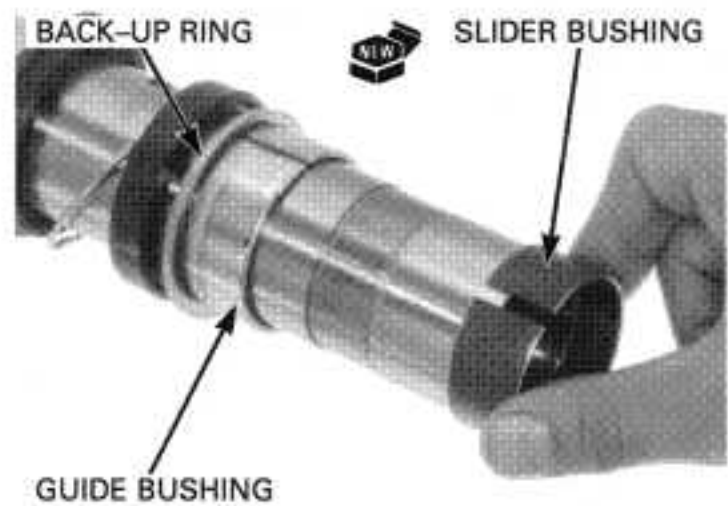

Apply the recommended fork fluid to the slider bushing and guide bushing.  
Install the fork slider into the outer pipe.

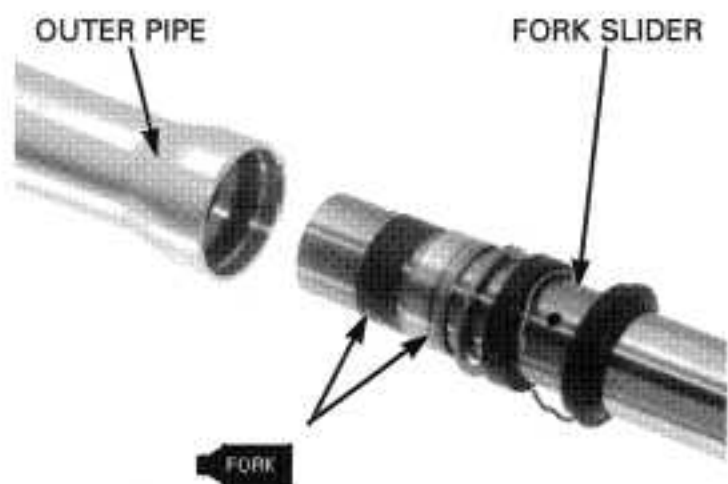

Drive the oil seal in using the special tools.

**TOOL:**  
Fork seal driver, 45 mm      07KMD-KZ30100

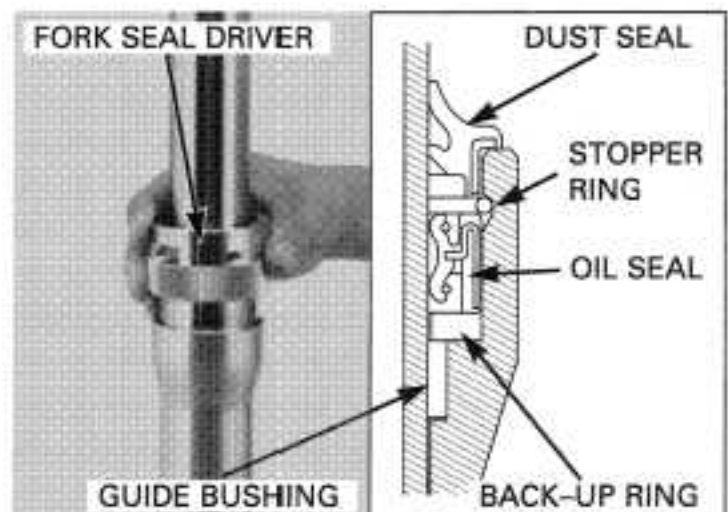



Install the stopper ring into the groove in the outer pipe.

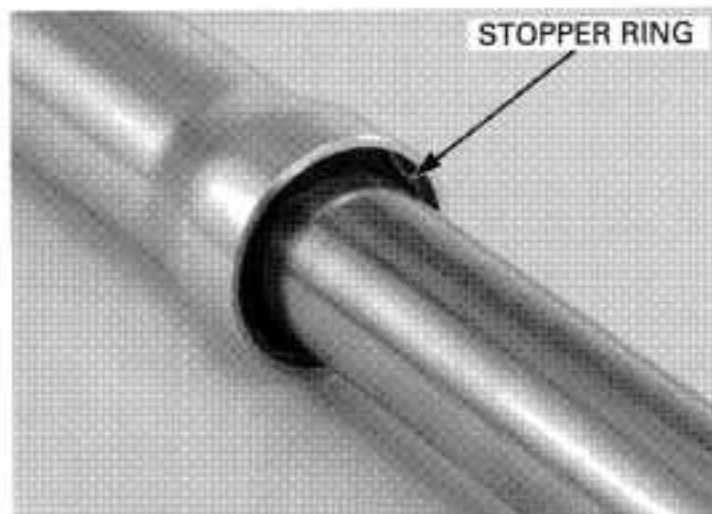

Install the dust seal.

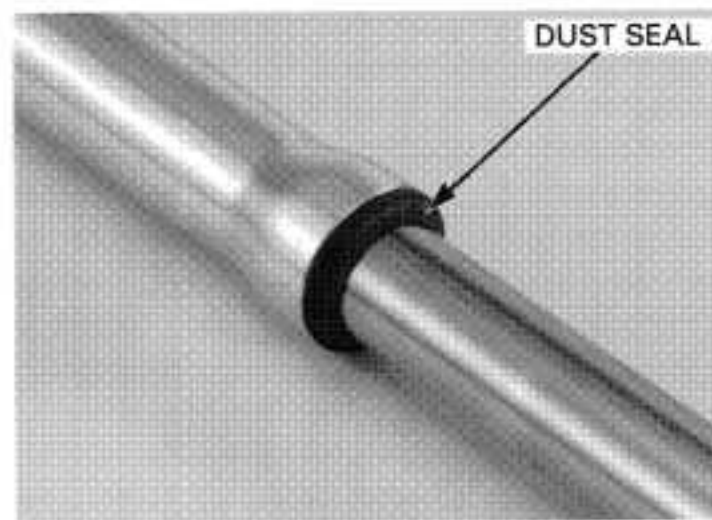

Pour the specified amount of the recommended fork fluid into the fork.

**RECOMMENDED FORK FLUID:**  
Pro Honda Suspension Fluid SS-8

**FORK FLUID CAPACITY:**  
780 ± 2.5 cm<sup>3</sup> (26.4 ± 0.08 US oz,  
27.5 ± 0.09 Imp oz)

Pump the outer pipe several times.

Measure the oil level from the top of the outer pipe while compressing the outer pipe all the way after stroking the outer pipe slowly more than 5 times.

**FORK FLUID LEVEL: 101 mm (4.0 in)**

Wipe off any excessive fluid from fork spring and collar.

Install the fork spring with the tapered end facing up. Install the fork spring joint plate and spring collar.

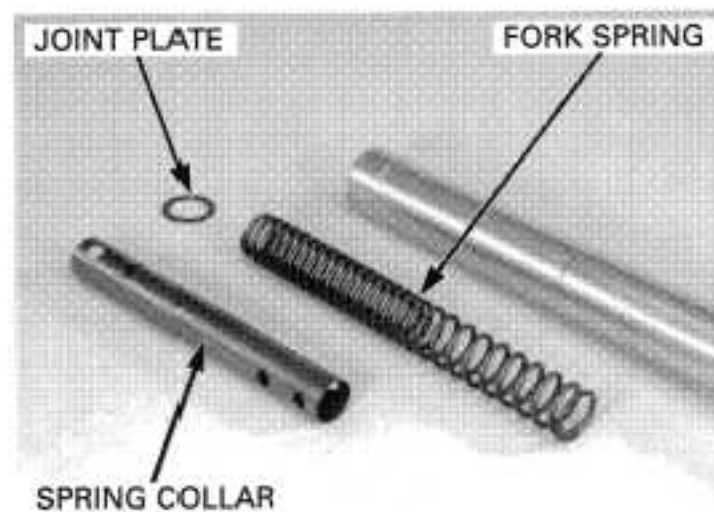
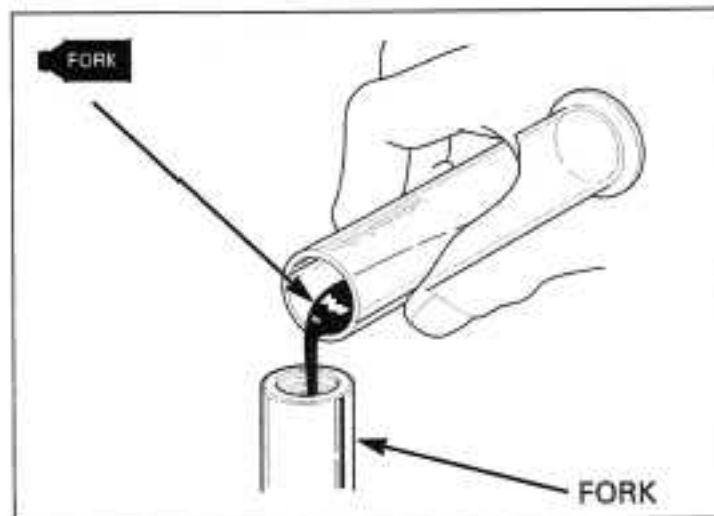



## FRONT WHEEL/SUSPENSION/STEERING

Install the rebound rod assembly.

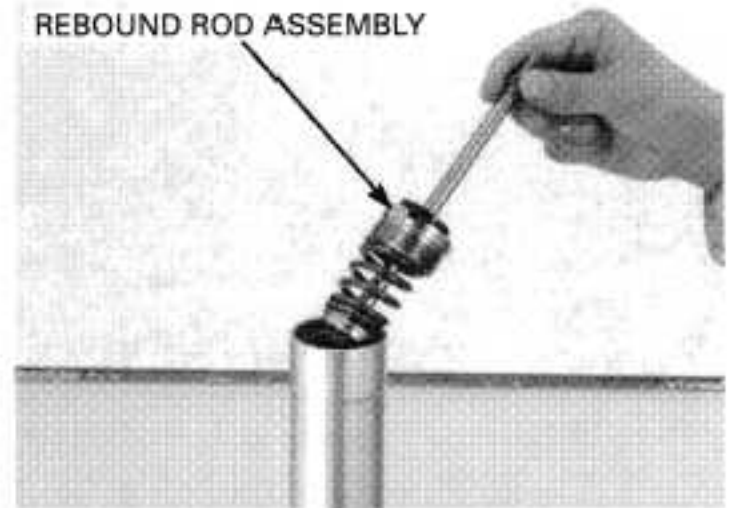

Install and tighten the inner fork bolt to the specified torque.

**TOOL:**

Lock nut wrench, 36 x 44 mm 07VMA-MZ0010A

**TORQUE:** 98 N·m (10.0 kgf·m, 72 lbf·ft)

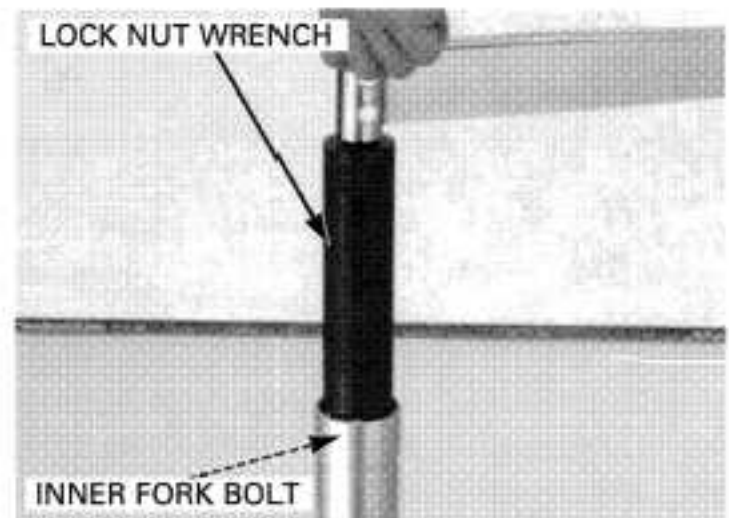

Install the rubber stopper onto the rod.

Screw the rod lock nut fully by hand.

Apply the recommended fork fluid to the new O-ring and install it onto the fork cap.

Install the fork cap onto the rebound rod.

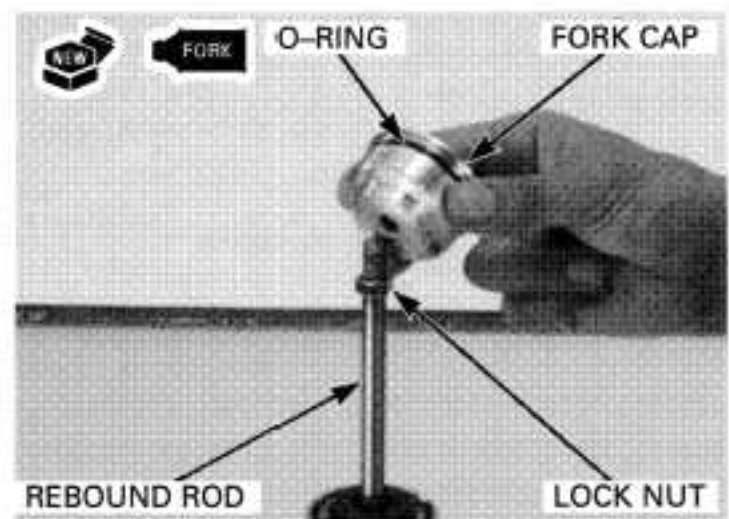

Hold the fork cap and tighten the lock nut to the specified torque.

**TORQUE:** 20 N·m (2.0 kgf·m, 14 lbf·ft)

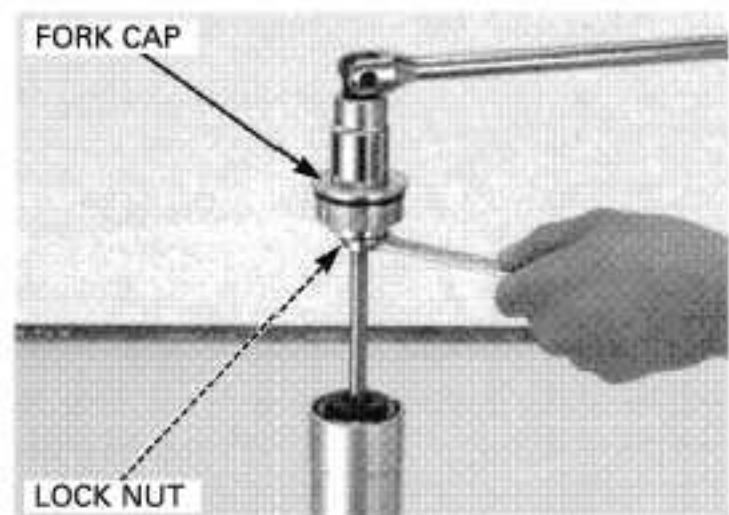

Pull up the rubber stopper over the lock nut.

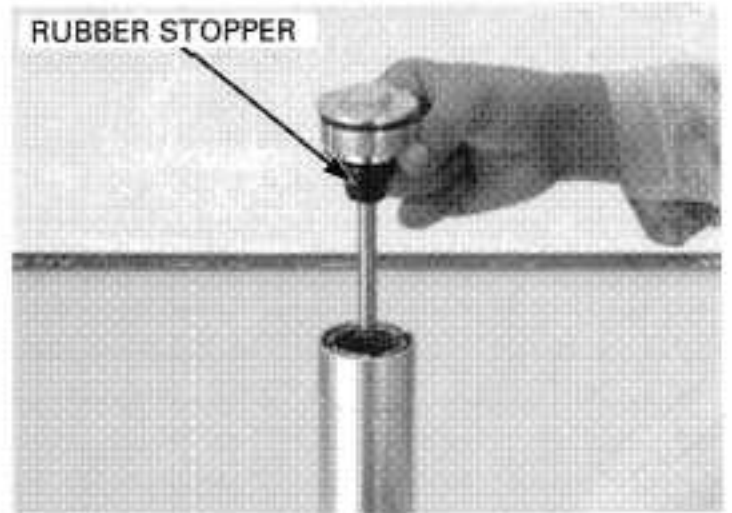

*Tighten the fork cap after installing the fork into the top bridge.*

Screw the fork cap into the outer pipe.

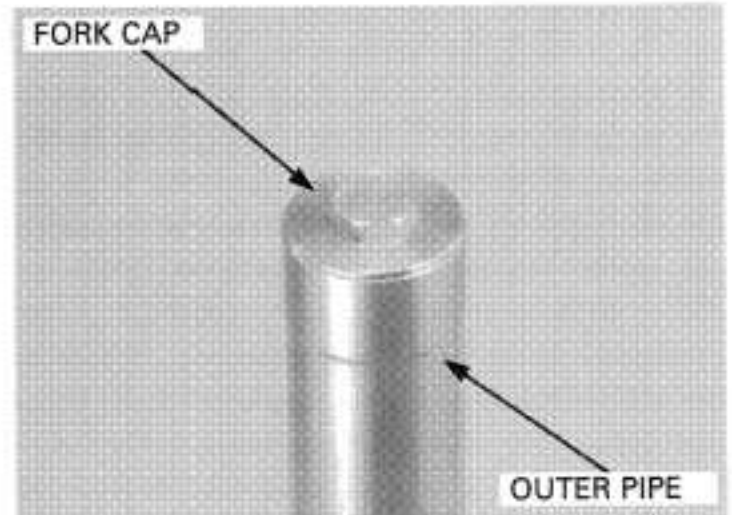

**INSTALLATION**

*Route the wires and cables properly (page 1-23).*

Install the fork assembly into the steering stem and fork top bridge. Align the top end of the outer pipe with the upper surface of the top bridge and tighten the bottom bridge pinch bolts to the specified torque.

**TORQUE: 24 N·m (2.4 kgf·m, 17 lbf·ft)**

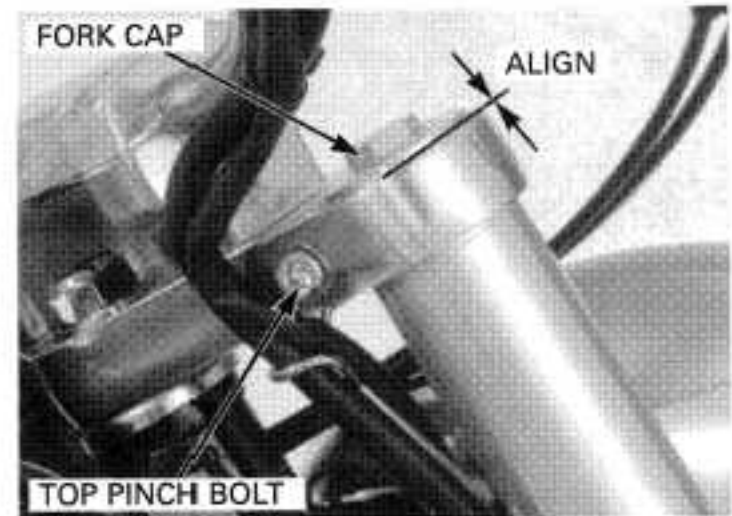

Tighten the fork cap if it was removed.

**TORQUE: 34 N·m (3.5 kgf·m, 25 lbf·ft)**

Tighten the fork top bridge pinch bolt to the specified torque.

**TORQUE: 55 N·m (5.6 kgf·m, 41 lbf·ft)**

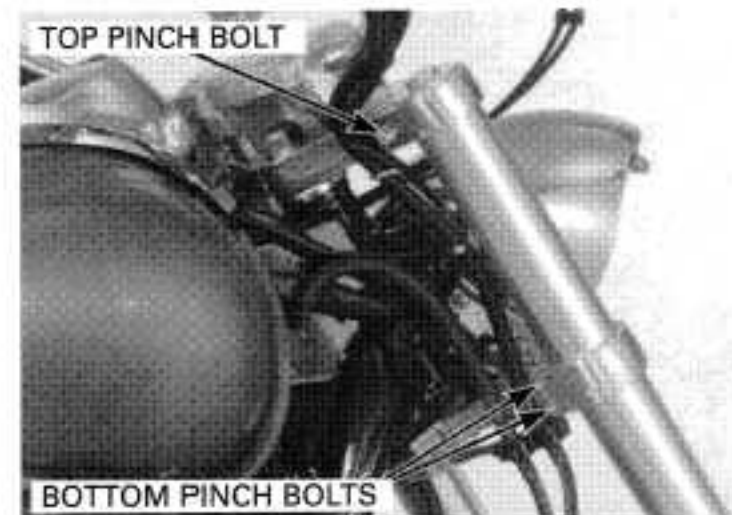

## FRONT WHEEL/SUSPENSION/STEERING

Install the front fender with the fork protectors.  
Install and tighten the socket bolts securely.

Install the front wheel (page 13-13).

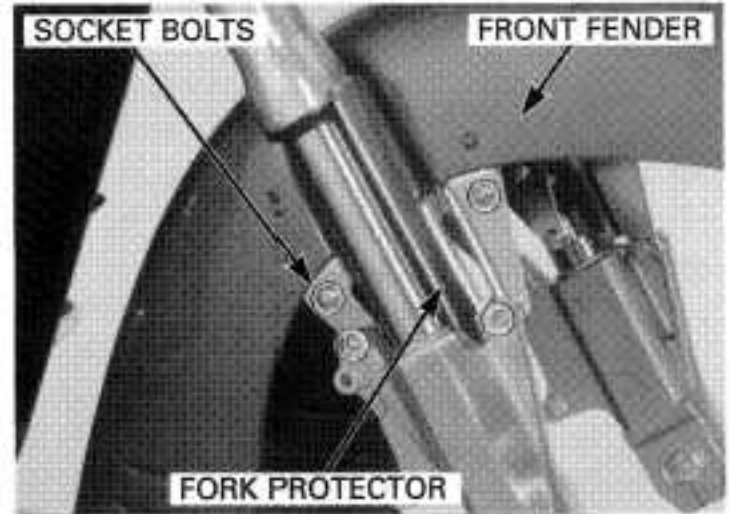

## STEERING STEM

### REMOVAL

Remove the following:

- headlight and headlight case (page 19-5)
- handlebar (page 13-3)
- turn signal assembly (page 19-5)
- front wheel (page 13-8)

Remove the bolts and front brake pipe clamps from the steering stem.

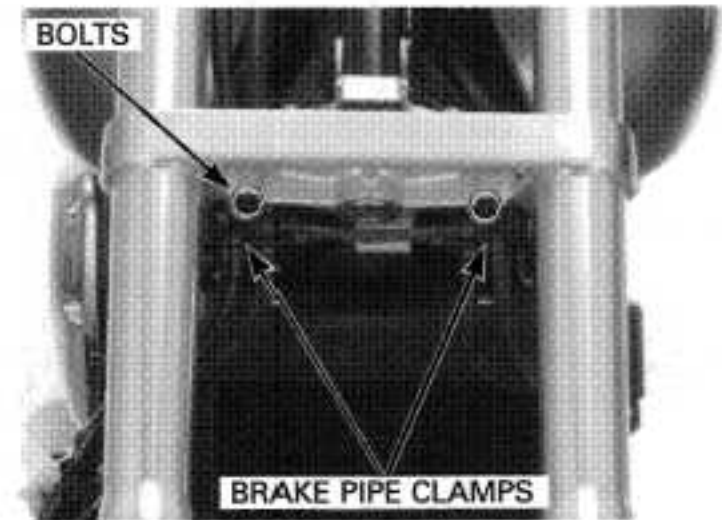

Remove the bolt and front brake hose clamp from the top bridge.

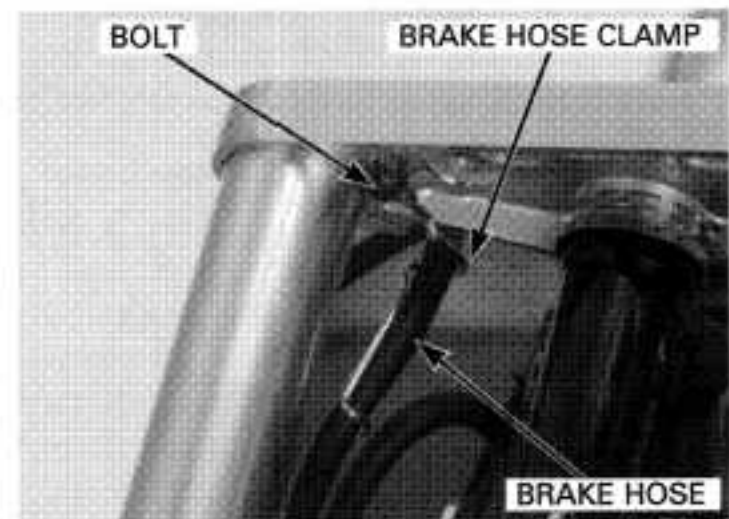

Remove the nuts, bolts and headlight stay from the steering stem.

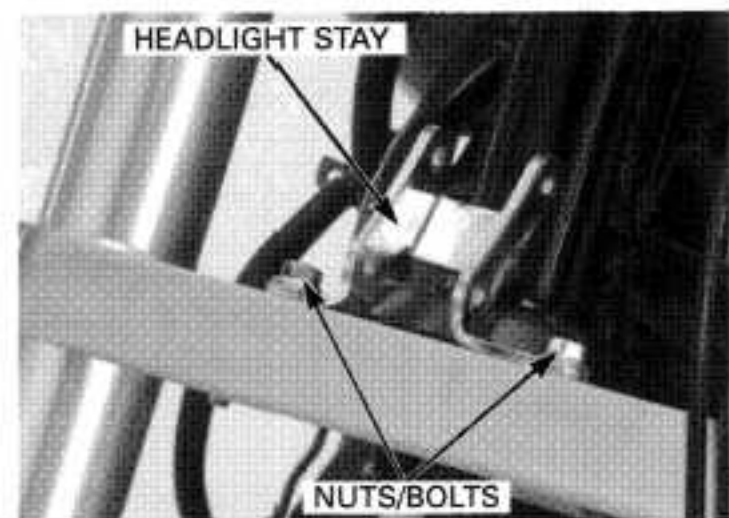

Loosen the steering stem nut.

Remove the fork legs (page 13-14), then remove the steering stem nut and washer.

Remove the top bridge.

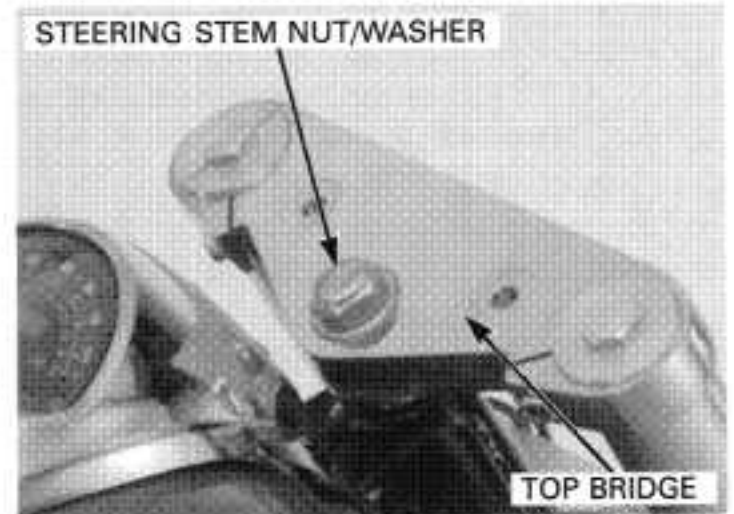

Straighten the lock washer tabs, and remove top adjusting nut B and the lock washer.



Loosen top adjusting nut A, hold the steering stem and remove top adjusting nut A using the special tool.

**TOOL:**  
Steering stem socket                      07916-3710100

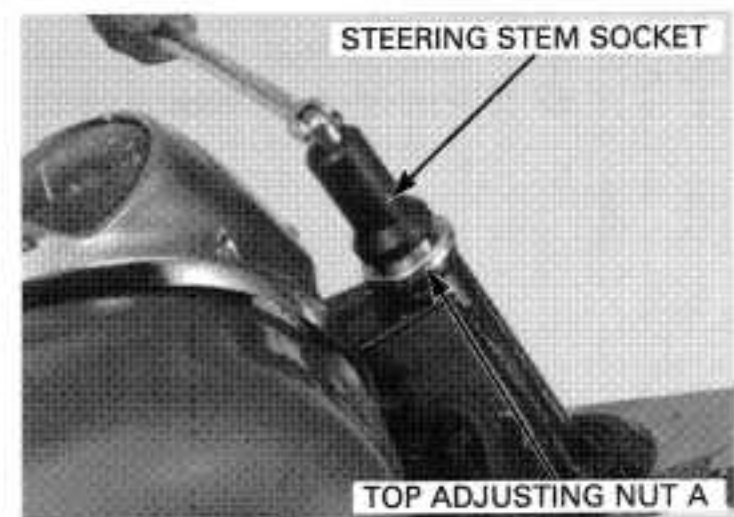

Remove the upper bearing and steering stem/lower bearing.

*Always replace the bearings and races as a set.*

Check the steering bearings and races for wear or damage.

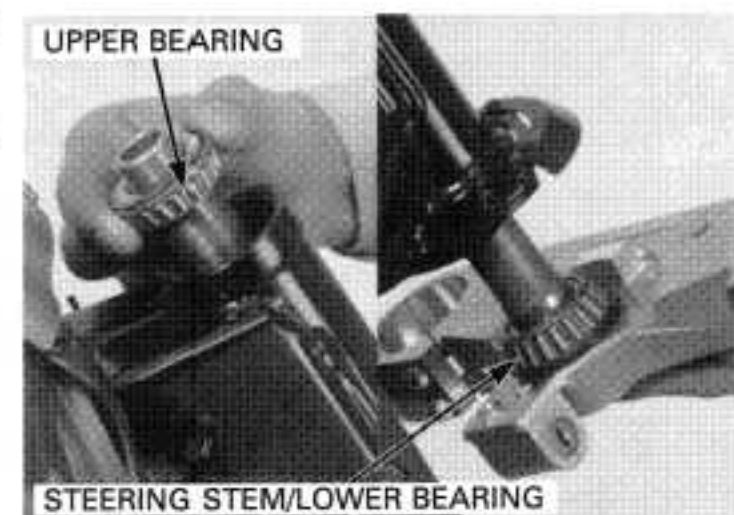



## BEARING REPLACEMENT

Drive out the upper bearing outer race using the special tools.

**TOOLS:**

Driver 07949-3710001  
Attachment, 37 x 40 mm 07746-0010200

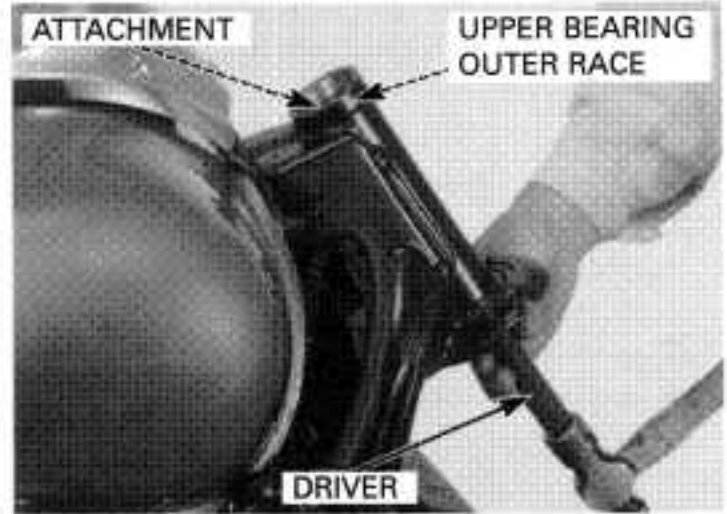

Drive out the lower bearing outer race using the special tools.

**TOOLS:**

Bearing race remover 07946-3710500  
Driver 07949-3710001  
Attachment, 37 x 40 mm 07746-0010200

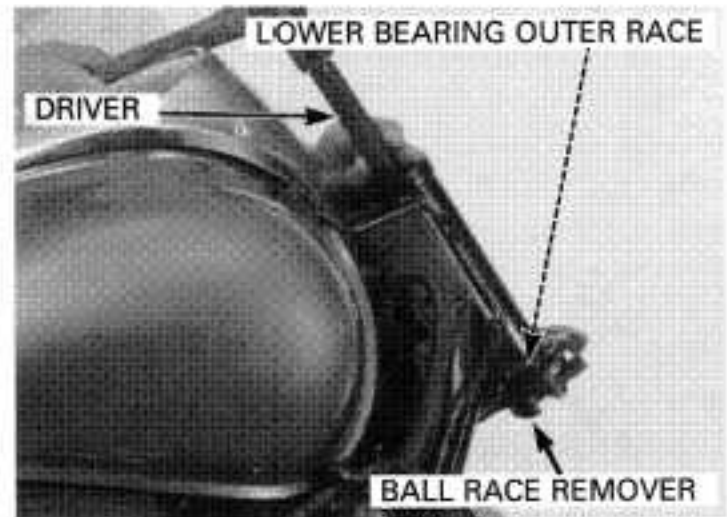

Temporarily install the steering stem nut to prevent the threads from being damaged when removing the lower bearing inner race from the stem.

Remove the lower bearing and dust seal with a chisel or equivalent tool, being careful not to damage the stem.

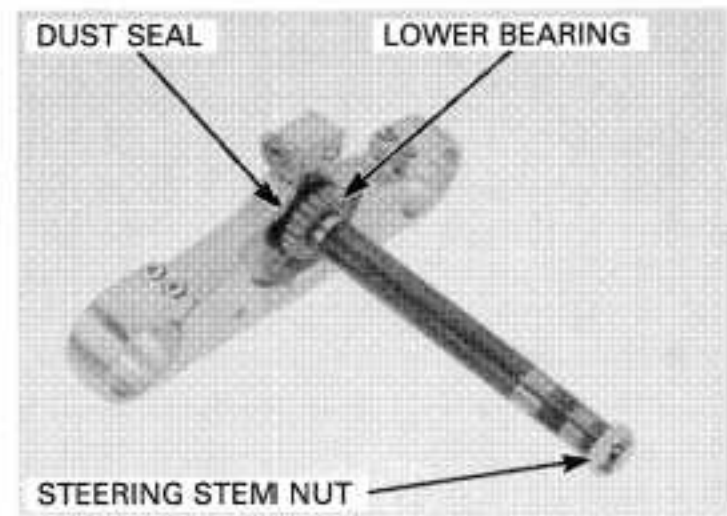

Apply grease to new dust seal lips and install it over the steering stem.

Install a new lower bearing using the special tool and a hydraulic press.

**TOOLS:**

Steering stem driver 07946-MB00000  
Pilot, 35 mm 07746-0040800

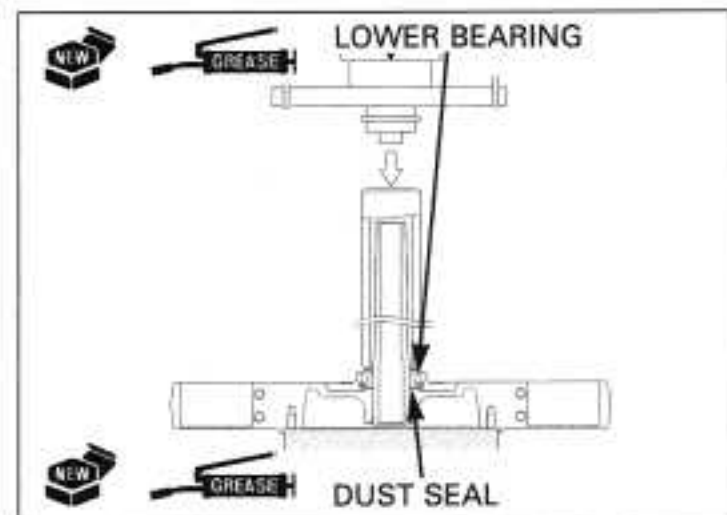



INSTALLATION

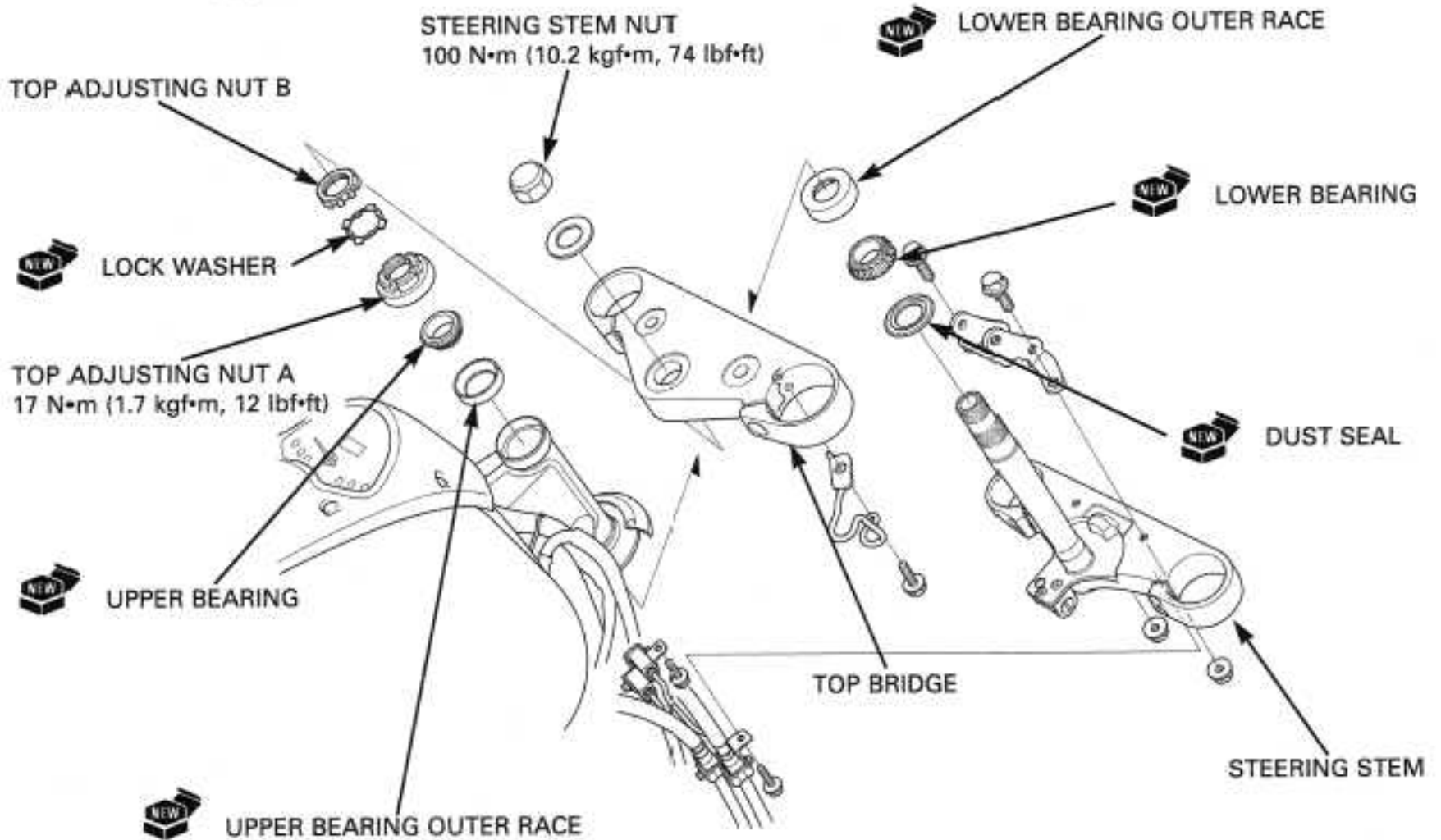

Drive a new lower bearing outer race into the steering head pipe using the special tools.

TOOLS:

Driver 07749-0010000  
Attachment, 52 x 55 mm 07746-0010400

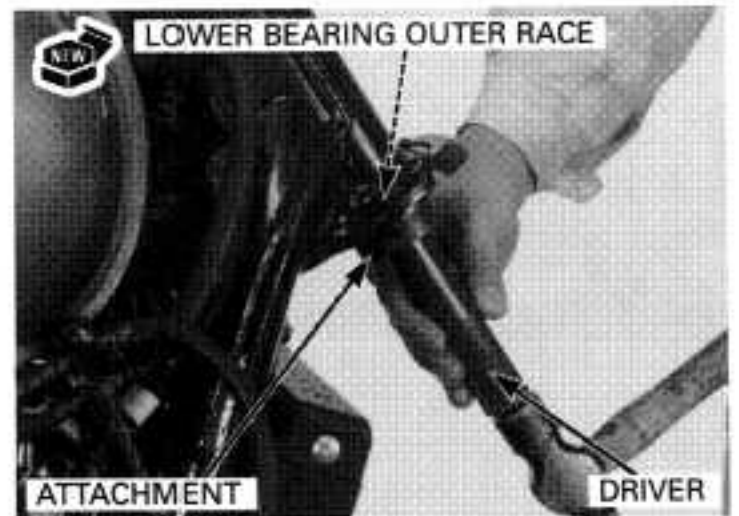

Drive a new upper bearing outer race into the steering head pipe using the special tools.

TOOLS:

Driver 07749-0010000  
Attachment, 42 x 47 mm 07746-0010300

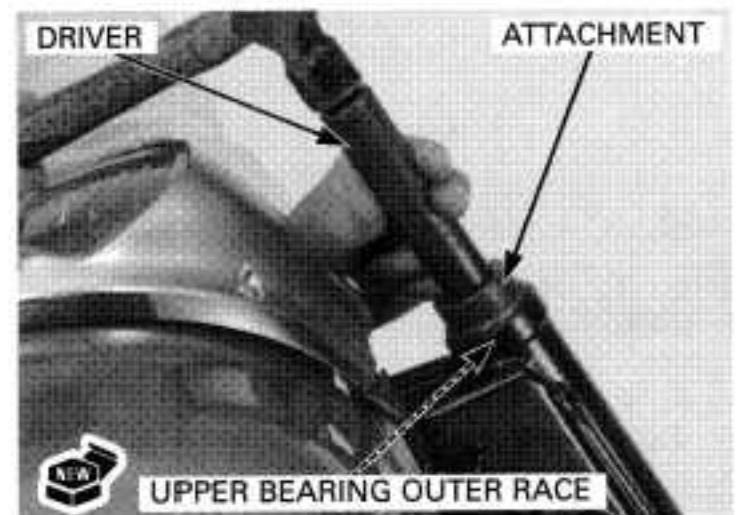

## FRONT WHEEL/SUSPENSION/STEERING

Apply 3 g (0.11 oz) of grease to the upper and lower bearings.  
Install the steering stem into the steering head pipe.

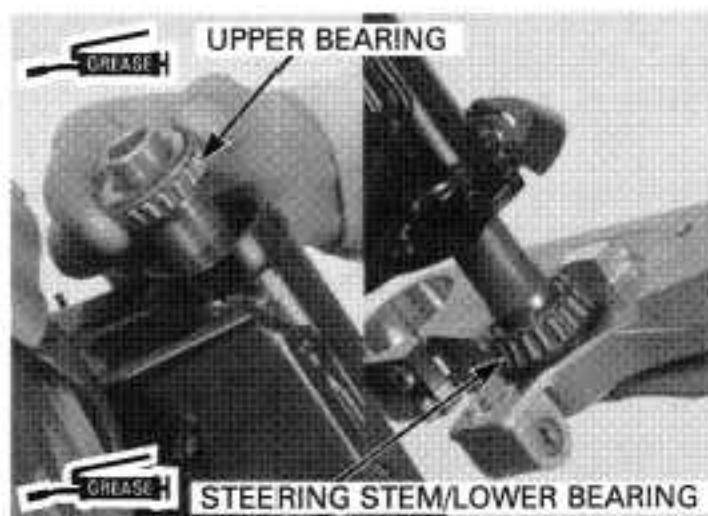

Apply engine oil to the threads of top adjusting nut A.

1. Tighten top adjusting nut A as follows:  
Install and tighten top adjusting nut A to the specified torque.

**TOOL:**

Steering stem socket                      07916-3710100

**TORQUE:** 40 N·m (4.1 kgf·m, 30 lbf·ft)



2. Move the steering stem to the right and left, lock-to-lock, five times to seat the bearings.  
Make sure the steering stem moves smoothly, without play or binding; then loosen top adjusting nut A.

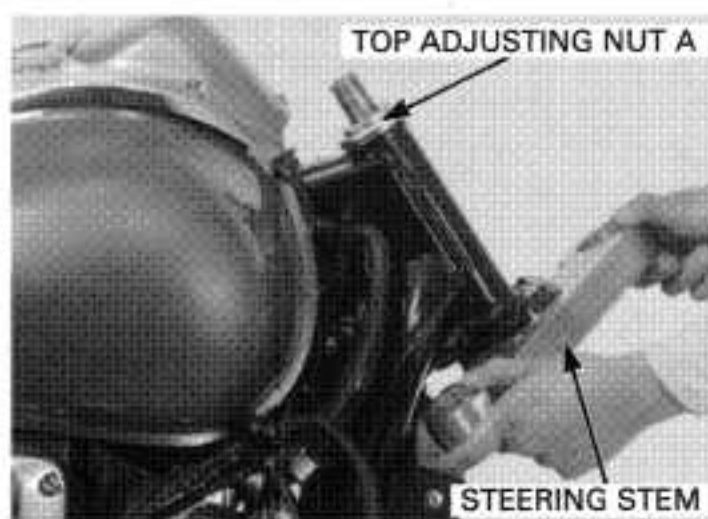

3. Retighten top adjusting nut A to the specified torque.

**TOOL:**

Steering stem socket                      07916-3710100

**TORQUE:** 17 N·m (1.7 kgf·m, 12 lbf·ft)



4. Move the steering stem to the right and left, lock-to-lock, five times to seat the bearings and then retighten top adjusting nut A to the same torque.

5. Repeat step 4 several times to seat the bearings.

Make sure the steering stem moves smoothly, without play or binding.

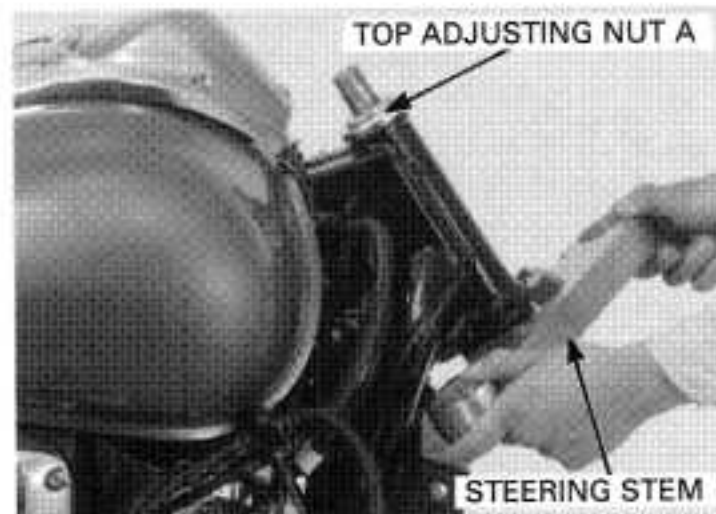

Install a new lock washer onto the steering stem.

Align the tabs of the lock washer with the grooves in top adjusting nut A and bend two opposite tabs (shorter) down into the groove in top adjusting nut A.

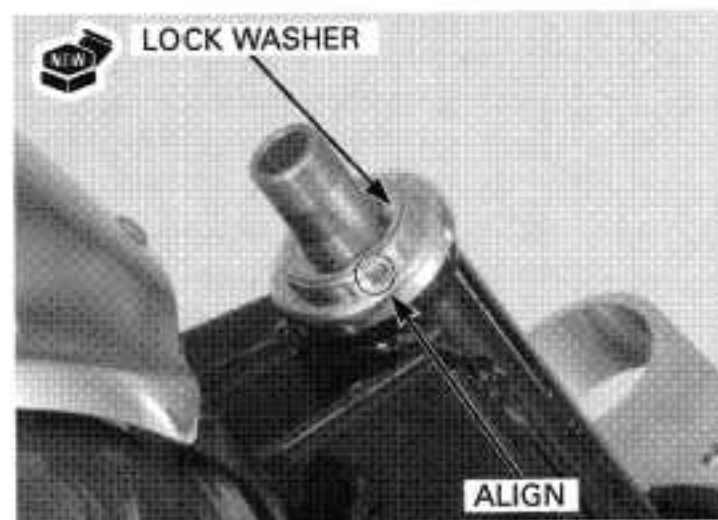

Install and finger tighten top adjusting nut B. Hold top adjusting nut A and further tighten top adjusting nut B within 1/4 of a turn (90°) enough to align its grooves with the lock washer tabs.

Bend the lock washer tabs up into the groove in top adjusting nut B.



Install the top bridge.

Install the fork legs (page 13-31).

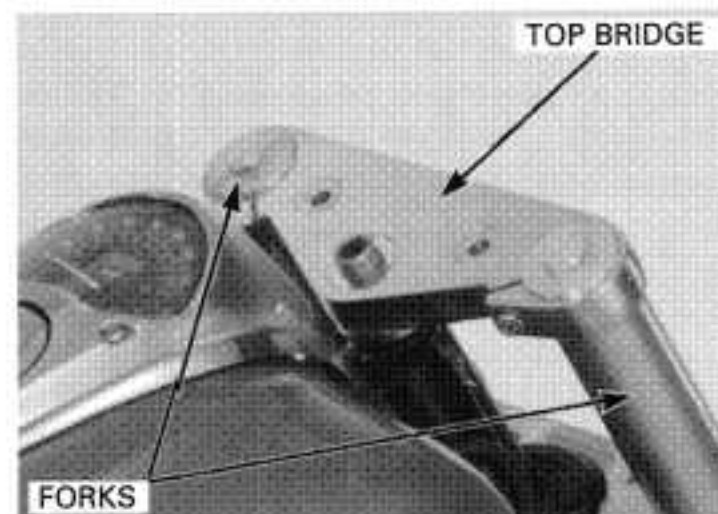

## FRONT WHEEL/SUSPENSION/STEERING

Install the washer.  
Install and tighten the steering stem nut to the specified torque.

**TORQUE: 100 N·m (10.2 kgf·m, 74 lbf·ft)**

Make sure the steering stem moves smoothly without play or binding.

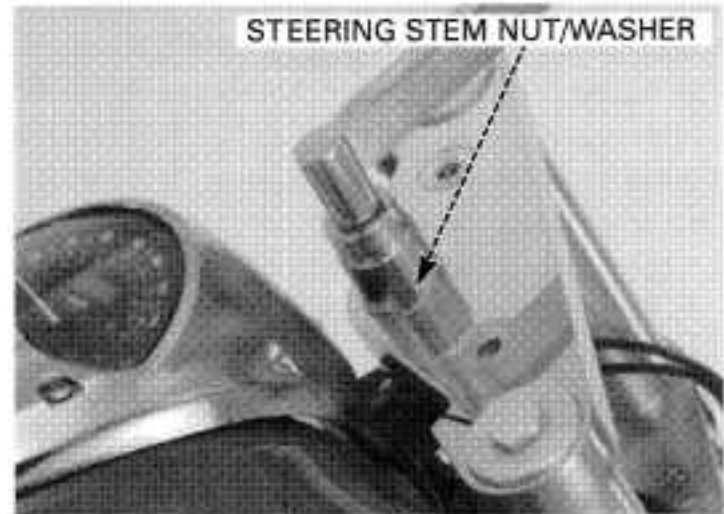

Install the headlight stay and tighten the bolts and nuts.  
Tighten the nuts securely.

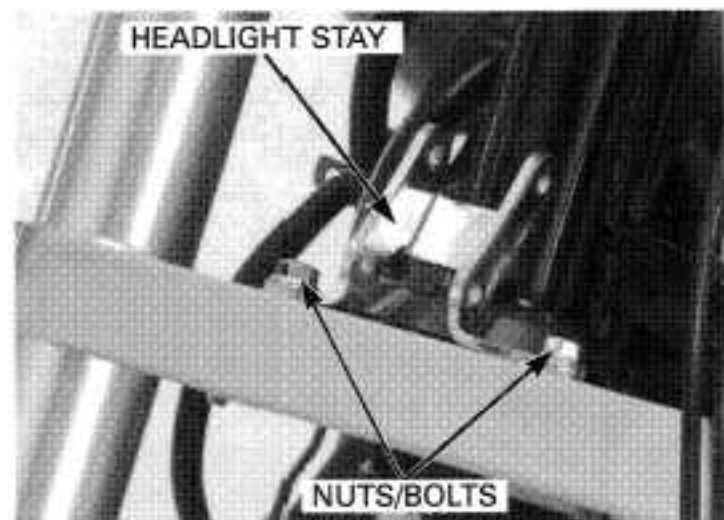

Install the brake hose clamp and tighten the bolt securely.

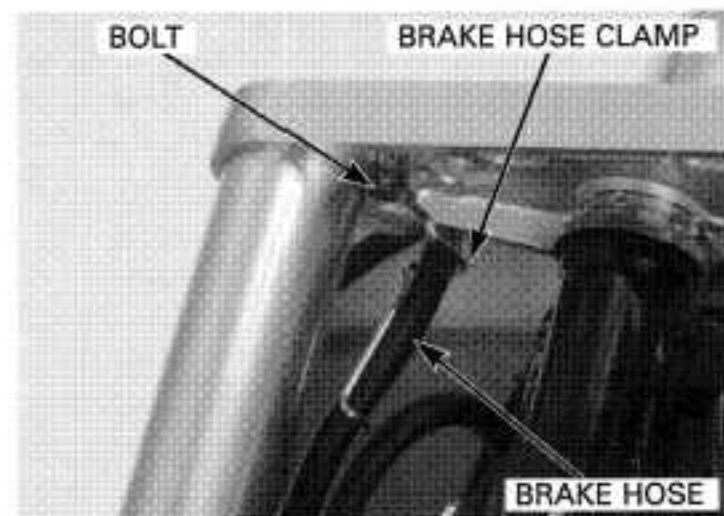

Install the front brake hose clamps with the bolts.

Install the following:

- front wheel (page 13-13)
- turn signal assembly (page 19-5)
- handlebar (page 13-5)
- headlight and headlight case (page 19-5)

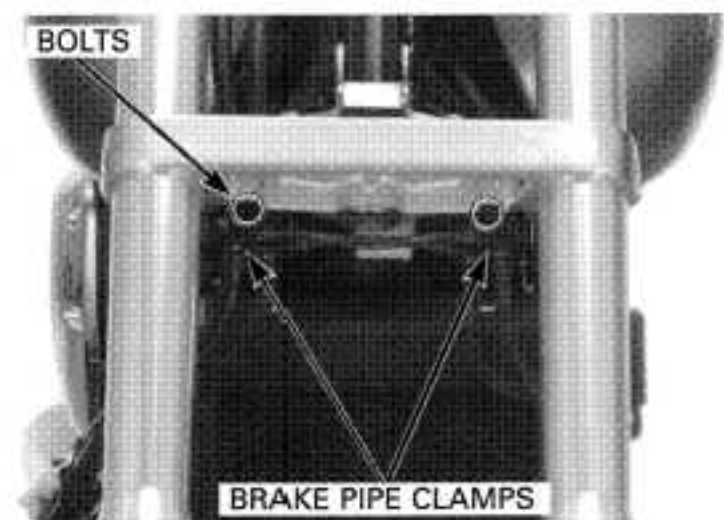



**STEERING HEAD BEARING PRE-LOAD**

Raise the front wheel off the ground.  
Position the steering stem to the straight ahead position.  
Hook a spring scale to the fork pipe between the fork interference.  
Pull the spring scale at the point where the steering stem just starts to move for right and left turns.

**STEERING BEARING PRE-LOAD:**  
**7.8 – 11.8 N (0.8 – 1.2 kg)**

If the readings do not fall within the limits, readjust the steering bearing adjustment nut.

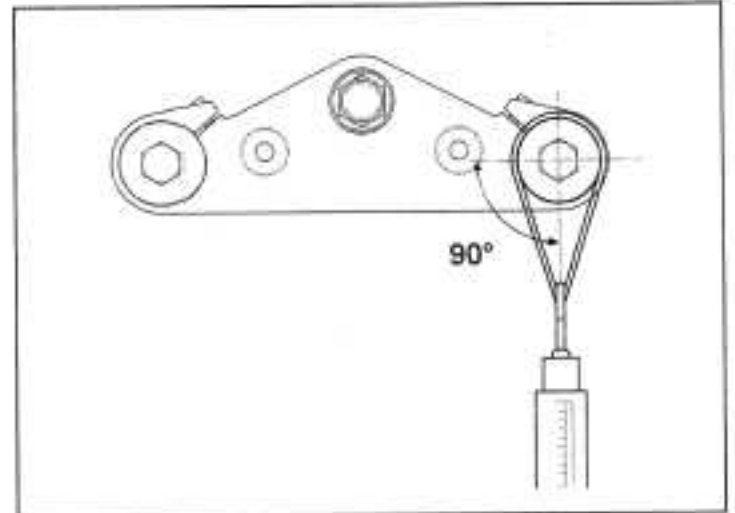



## REAR WHEEL/SUSPENSION

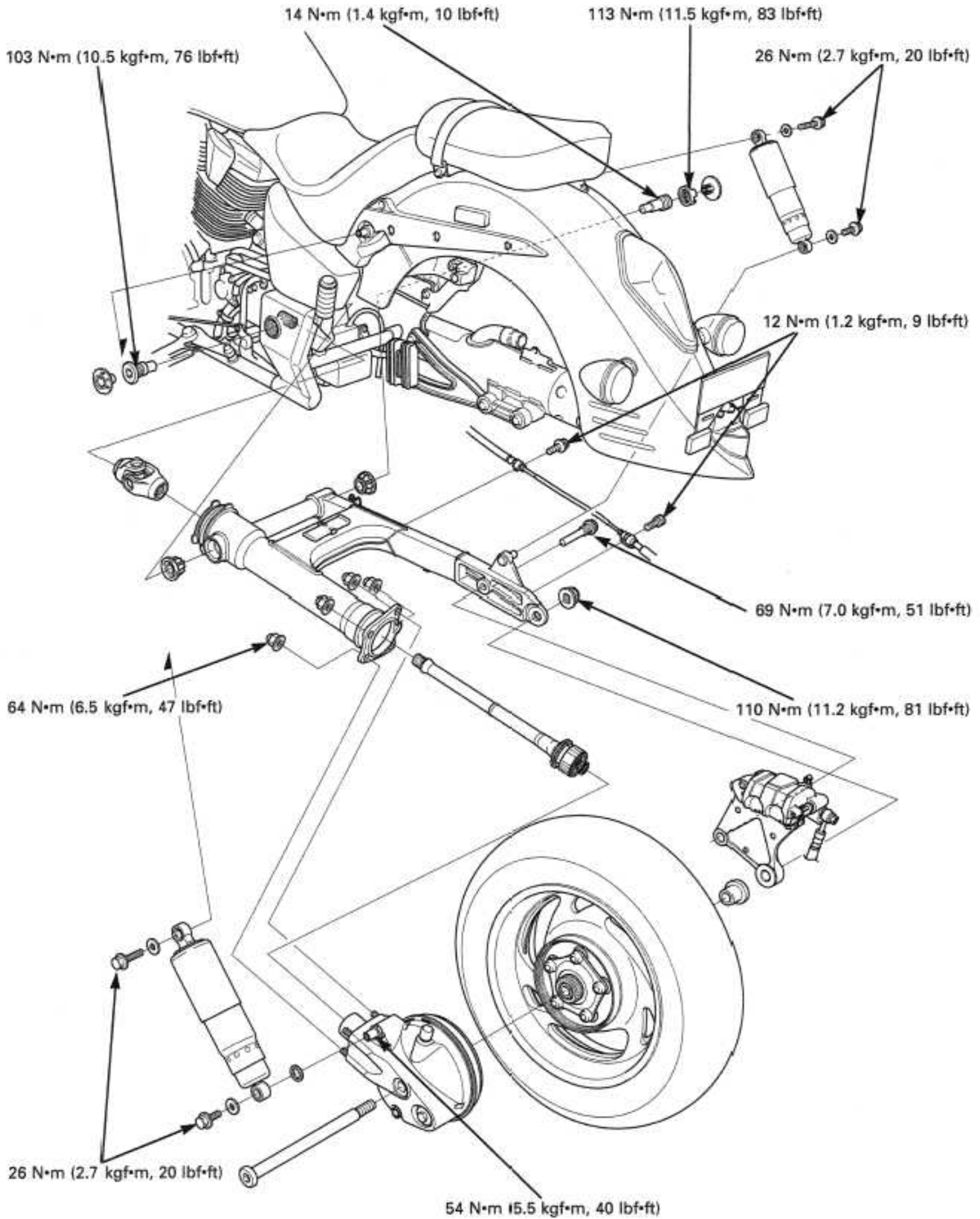

# 14. REAR WHEEL/SUSPENSION

SERVICE INFORMATION	14-1	SHOCK ABSORBER	14-11
TROUBLESHOOTING	14-2	SWINGARM	14-12
REAR WHEEL	14-3		

## SERVICE INFORMATION

### GENERAL

- Refer to section 15 for hydraulic brake system information.
- A contaminated brake disc or pad reduces stopping power. Discard contaminated pads and clean a contaminated disc with a high quality brake degreasing agent.
- When servicing the rear wheel, shock absorber, or swingarm, raise the rear wheel off the ground by supporting the frame securely.
- Use only genuine Honda replacement bolts and nuts for all suspension pivot and mounting points.
- When using the lock nut wrench, use a 20-inch long deflecting beam type torque wrench. The lock nut wrench increases the torque wrench's leverage, so the torque wrench reading will be less than the torque actually applied to the lock nut. The specification given on the next page is the actual torque applied to the lock nut, not the reading on the torque wrench when used with the lock nut wrench. The procedure later in the text gives both the actual and indicated torque.

### SPECIFICATION

Unit: mm (in)

ITEM		STANDARD	SERVICE LIMIT
Minimum tire tread depth		—	2.0 (0.08)
Cold tire pressure	Up to 90 kg (200 lb) load	225 kPa (2.25 kgf/cm <sup>2</sup> , 33 psi)	—
	Up to maximum weight capacity	250 kPa (2.50 kgf/cm <sup>2</sup> , 36 psi)	—
Axle runout		—	0.2 (0.01)
Wheel rim runout	Radial	—	2.0 (0.08)
	Axial	—	2.0 (0.08)
Wheel balance weight		—	60 g (2.1 oz) max.
Shock absorber	Spring adjuster standard position	Position 2	—

14

### TORQUE VALUES

Rear axle nut	110 N•m (11.2 kgf•m, 81 lbf•ft)	U-nut.
Rear brake disc bolt	42 N•m (4.3 kgf•m, 31 lbf•ft)	ALOC bolt: replace with new one.
Final driven flange nut	88 N•m (9.0 kgf•m, 65 lbf•ft)	U-nut.
Left swingarm pivot bolt	103 N•m (10.5 kgf•m, 76 lbf•ft)	
Right swingarm pivot bolt	14 N•m (1.4 kgf•m, 10 lbf•ft)	
Right swingarm pivot lock nut	113 N•m (11.5 kgf•m, 83 lbf•ft)	
Rear shock absorber mounting bolt	26 N•m (2.7 kgf•m, 20 lbf•ft)	
Rear shock absorber lower mounting bolt final gear case side	54 N•m (5.5 kgf•m, 40 lbf•ft)	
Rear caliper stopper pin bolt	69 N•m (7.0 kgf•m, 51 lbf•ft)	ALOC bolt: replace with new one.
Brake hose clamp/stay bolt	12 N•m (1.2 kgf•m, 9 lbf•ft)	
Final gear case mounting nut	64 N•m (6.5 kgf•m, 47 lbf•ft)	

## REAR WHEEL/SUSPENSION

---

### TOOLS

Attachment, 37 x 40 mm	07746-0010200
Attachment, 42 x 47 mm	07746-0010300
Attachment, 52 x 55 mm	07746-0010400
Attachment, 24 x 26 mm	07746-0010700
Pilot, 20 mm	07746-0040500
Pilot, 30 mm	07746-0040700
Bearing remover head, 20 mm	07746-0050600
Driver	07749-0010000
Lock nut	07908-4690003
Driver	07949-3710001
Bearing remover shaft	07GGD-0010100

### TROUBLESHOOTING

#### Soft suspension

- Weak shock absorber spring
- Oil leakage from damper unit
- Incorrect suspension adjustment
- Low tire pressure

#### Hard suspension

- Damaged shock absorber mount bushing
- Incorrect suspension adjustment
- Damaged swingarm pivot bearing
- Bent damper rod
- High tire pressure

#### Rear wheel wobbles

- Bent rim
- Worn wheel bearings
- Faulty tire
- Unbalanced tire and wheel
- Low tire pressure
- Faulty swingarm pivot bearings

#### Wheel turns hard

- Faulty wheel bearings
- Brake drags (section 15)
- Bent rear axle

#### Suspension noise

- Binding shock case
- Faulty rear damper
- Loose fastener
- Worn suspension pivot bushings

## REAR WHEEL

### REMOVAL

Loosen the front/rear muffler stay nuts and bolts. Make space to attach the rear axle nut and the rear caliper stopper pin bolt.

Loosen and remove the rear axle nut. Remove the rear caliper stopper pin bolt.

Raise the rear wheel off the ground 13 inches and support the motorcycle firmly.

Remove the rear brake pads (page 15–11).

Pull out the rear axle, then remove the rear caliper from the brake disc.

Move the rear wheel to the right to separate it from the final gear case and remove the rear wheel.

*Do not operate the brake lever and brake pedal after removing the caliper. Do not hang the caliper from the brake hose. Do not twist the hose.*

Remove the collar from the right side of the rear wheel.

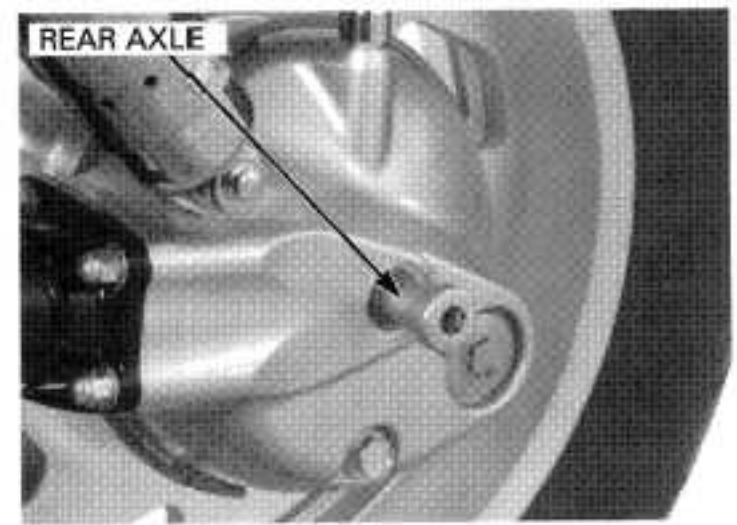
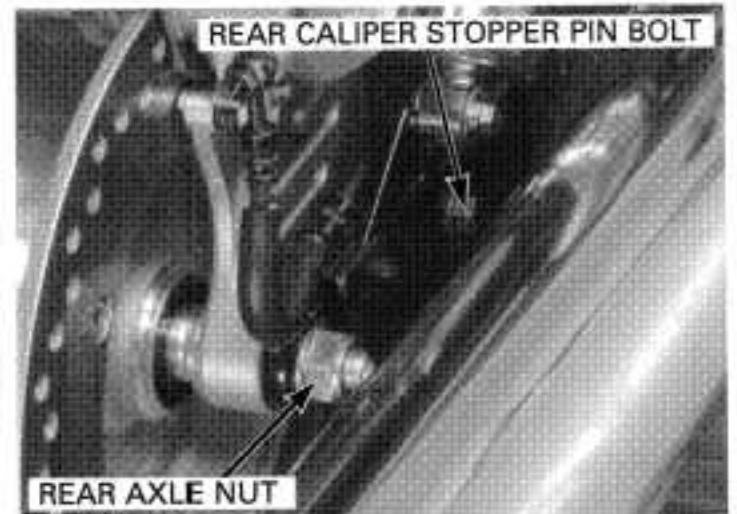

## REAR WHEEL/SUSPENSION

### INSPECTION

#### AXLE

Place the axle in V-blocks and measure the runout. Actual runout is 1/2 the total indicator reading.

**SERVICE LIMIT: 0.2 mm (0.01 in)**

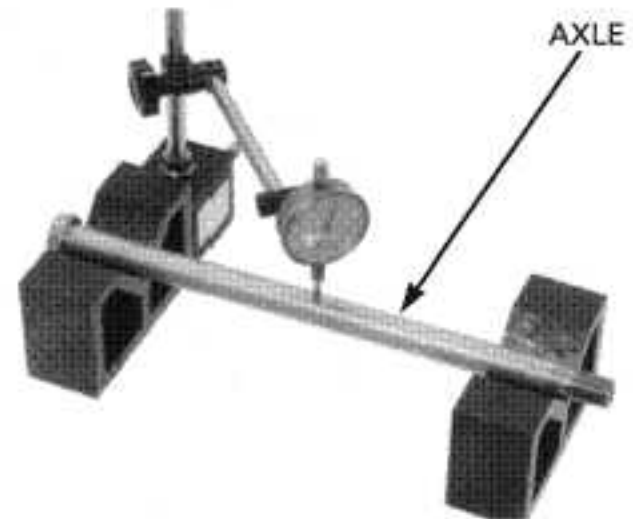

#### WHEEL

Check the rim runout by placing the wheel in a truing stand. Spin the wheel slowly and read the runout using a dial indicator. Actual runout is 1/2 the total indicator reading.

**SERVICE LIMIT: Radial: 2.0 mm (0.08 in)**  
**Axial: 2.0 mm (0.08 in)**

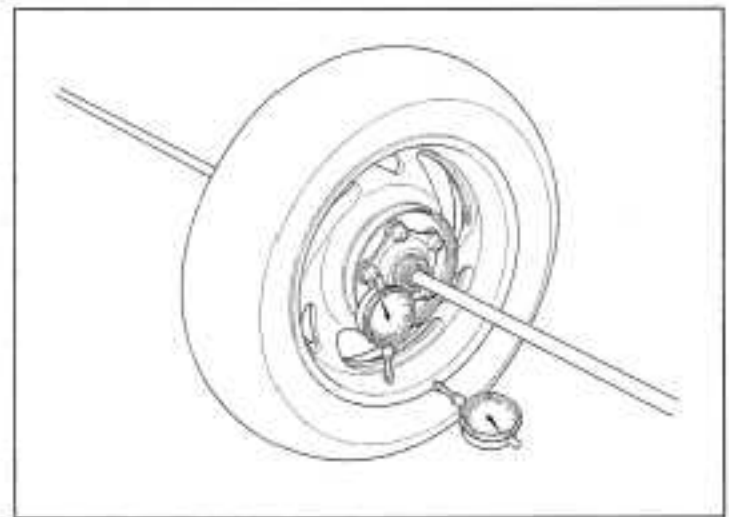

#### WHEEL BEARING

Turn the inner race of each bearing with your finger. The bearings should turn smoothly and quietly. Also check that the bearing outer race fits tightly in the hub.

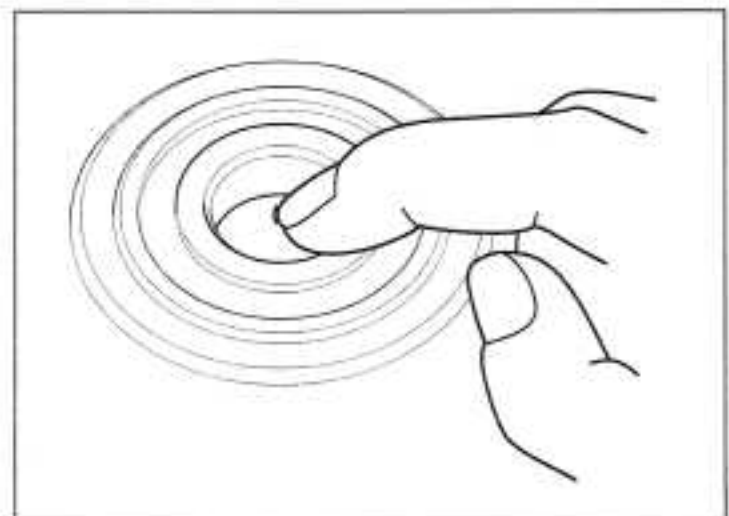

*Replace the wheel bearing in pairs.*

Remove and discard the bearings if the races do not turn smoothly, quietly, or if they fit loosely in the hub.

### DISASSEMBLY

Remove the dust seal from the right wheel hub.

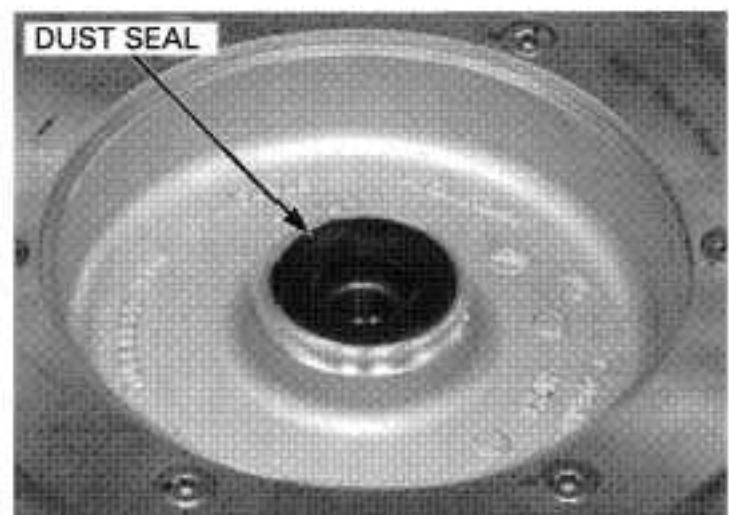



Remove the brake disc bolts and rear brake disc.

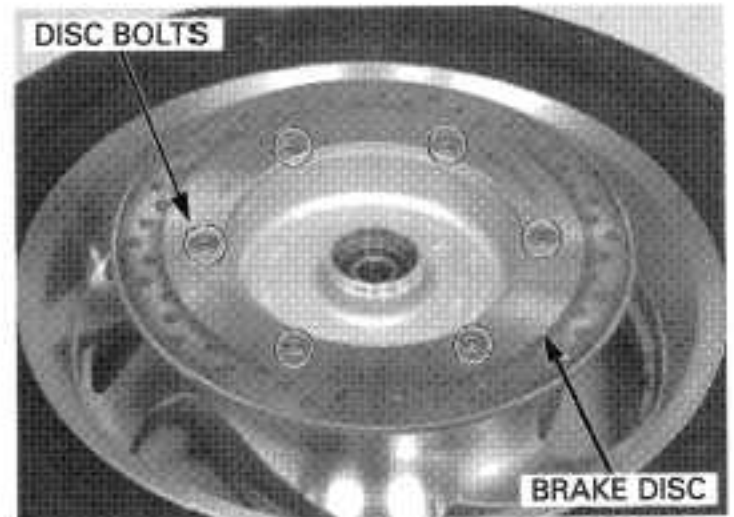

Remove the O-ring from the final driven flange.

Remove the final driven flange nuts and final driven flange A.

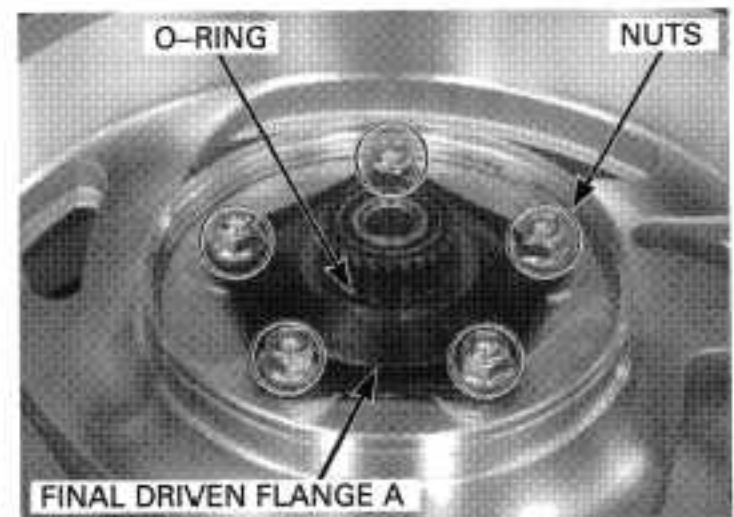

Remove the O-ring from the left wheel hub.

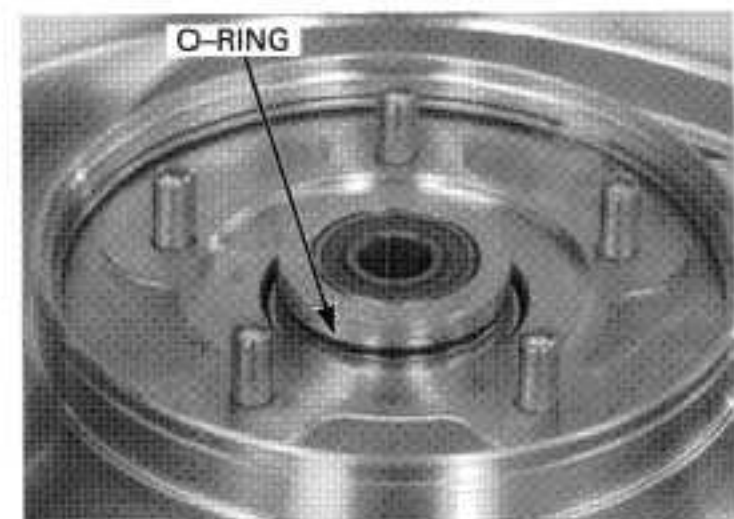

Remove the snap ring from the left wheel hub.

Remove final driven flange B from the left wheel hub.

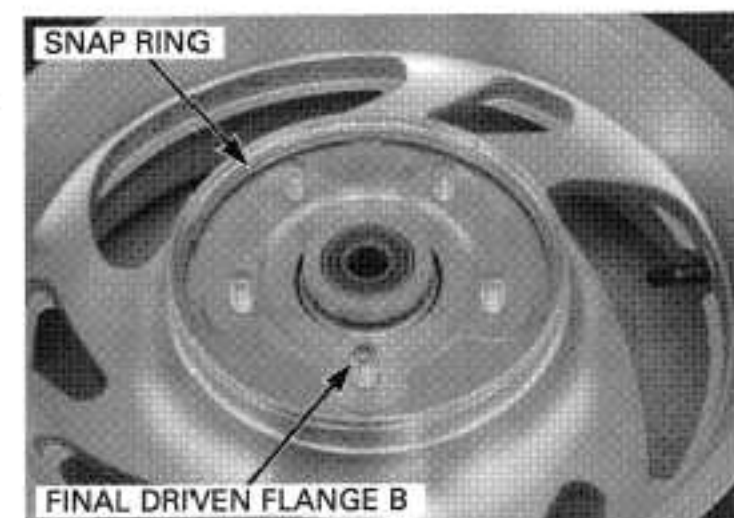

## REAR WHEEL/SUSPENSION

Remove the rear wheel rubber dampers.

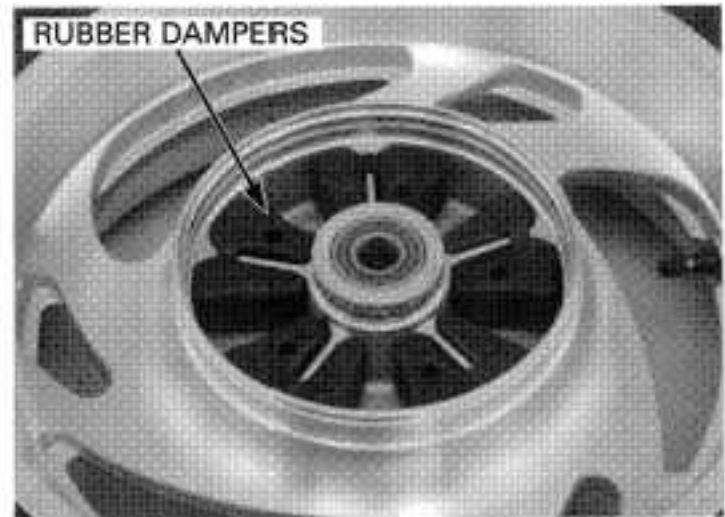

Install the bearing remover head into the bearing. From the opposite side of wheel, install the bearing remover shaft and drive the bearing out of the wheel hub. Remove the distance collar and drive out the other bearing.

**TOOLS:**  
Bearing remover shaft 07GGD-0010100  
Bearing remover head, 20 mm 07746-0050600

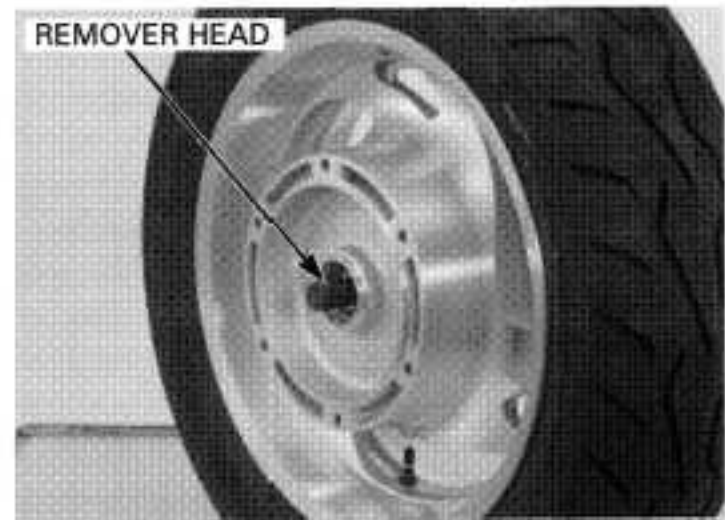

**FINAL DRIVEN FLANGE DISASSEMBLY/ASSEMBLY**  
Drive out rear axle distance collar A from final driven flange A.

Drive out the final driven flange bearing (6905 RS) from final driven flange A.

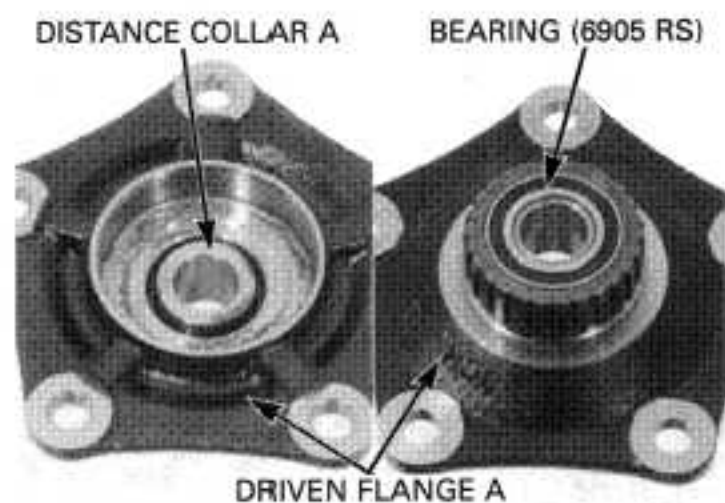

Drive in the final driven flange bearing (6905 RS) to final driven flange A until it is fully seated.

**TOOLS:**  
Driver 07749-0010000  
Attachment, 42 x 47 mm 07746-0010300  
Pilot, 20 mm 07746-0040500

Drive in rear axle distance collar A to final driven flange A.

**TOOLS:**  
Driver 07749-0010000  
Attachment, 24 x 26 mm 07746-0010700  
Pilot, 20 mm 07746-0040500

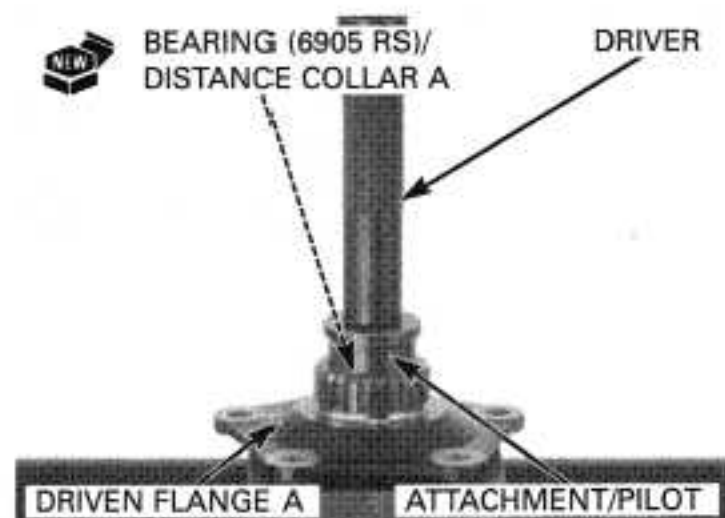

**ASSEMBLY**

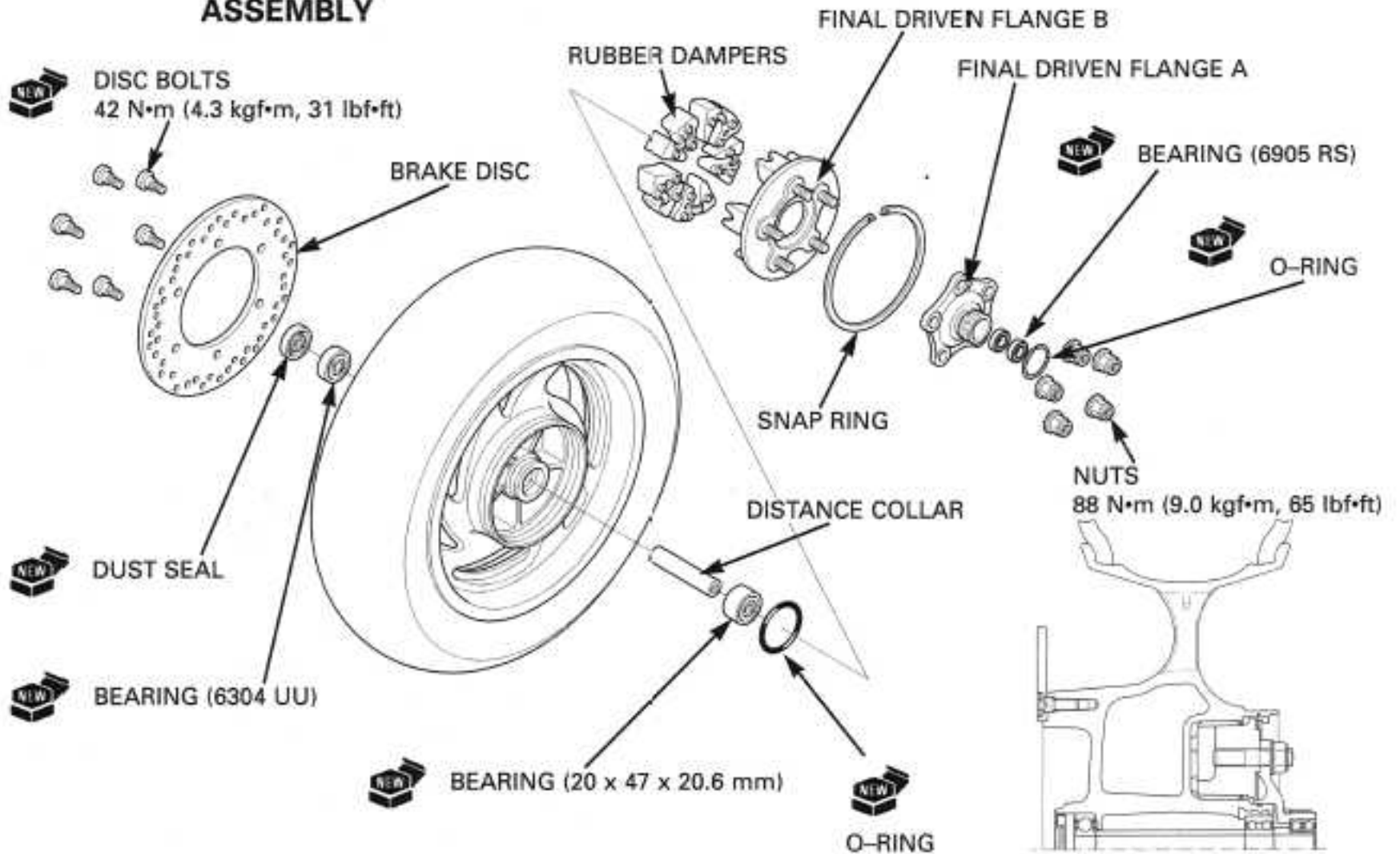

Drive in a new right bearing (6304 UU) securely with the mark facing up until it is seated.

**TOOLS:**

<b>Driver</b>	<b>07749-0010000</b>
<b>Attachment, 52 x 55 mm</b>	<b>07746-0010400</b>
<b>Pilot, 20 mm</b>	<b>07746-0040500</b>

Install the distance collar.  
Drive in a new left bearing (20 x 47 x 20.6 mm) securely with the mark facing up until it is seated.

**TOOLS:**

<b>Driver</b>	<b>07749-0010000</b>
<b>Attachment, 42 x 47 mm</b>	<b>07746-0010300</b>
<b>Pilot, 20 mm</b>	<b>07746-0040500</b>

Replace the rubber dampers as a set.

Check the rubber dampers for deterioration or damage and replace the rear wheel assembly with a new one if necessary.

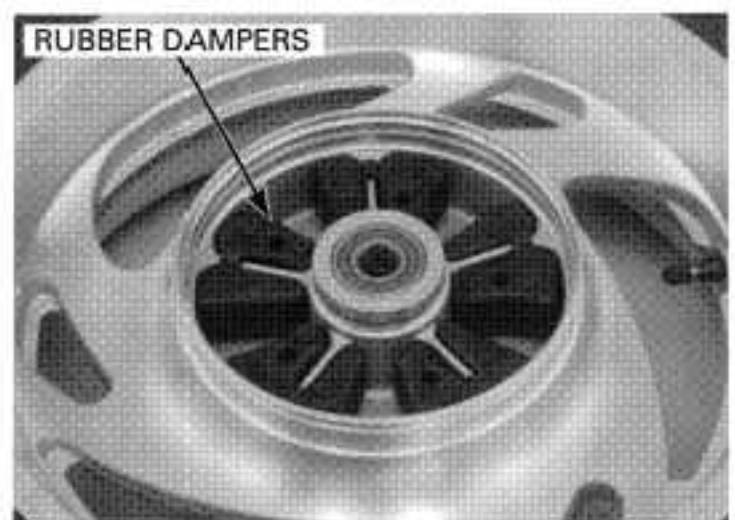
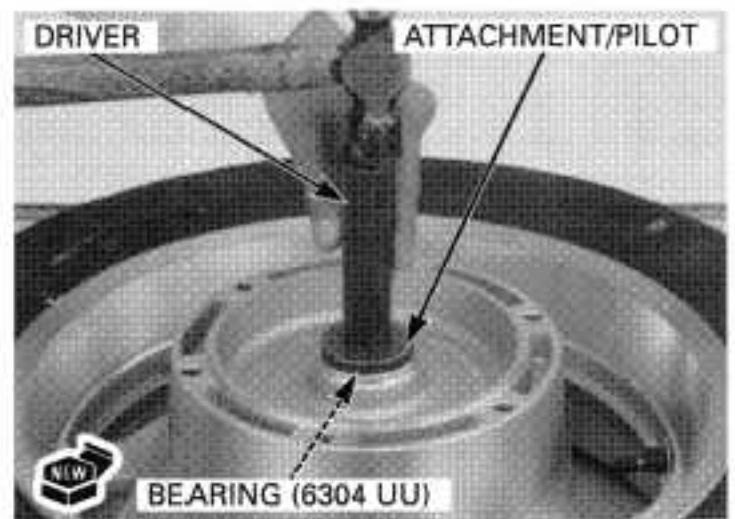

## REAR WHEEL/SUSPENSION

Install driven flange B to the left wheel hub.

Install the snap ring to the groove on the left wheel hub.

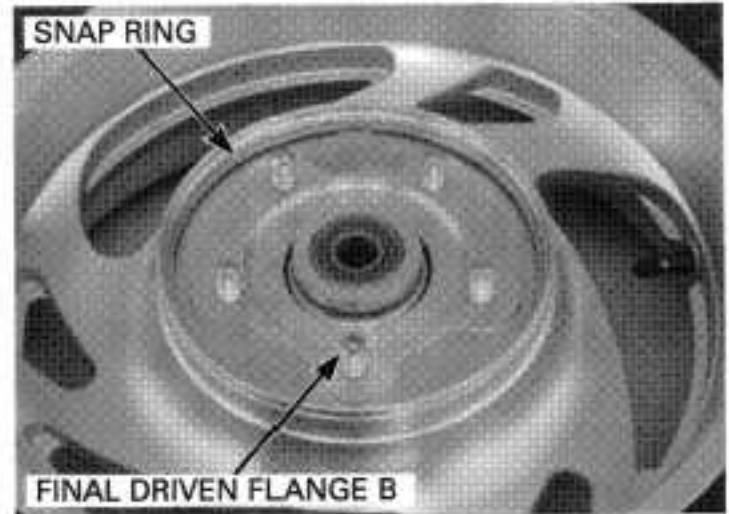

Coat a new O-ring with molybdenum disulfide paste and install it into the groove.

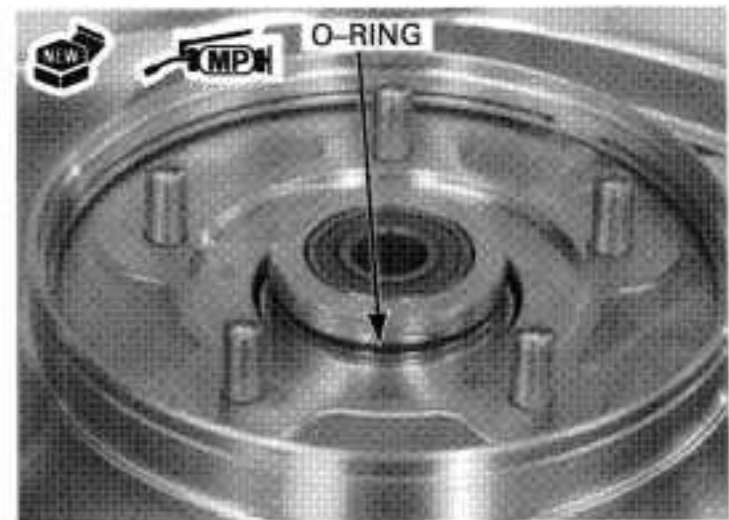

Apply 3 g (0.11 oz) of molybdenum disulfide paste to the mating surface of the rear wheel hub end and final driven flange A.

Install final driven flange A to the left wheel hub.

Coat a new O-ring with molybdenum disulfide paste and install it into the groove.

Install and tighten the final driven flange nuts to the specified torque.

**TORQUE: 88 N·m (9.0 kgf·m, 65 lbf·ft)**

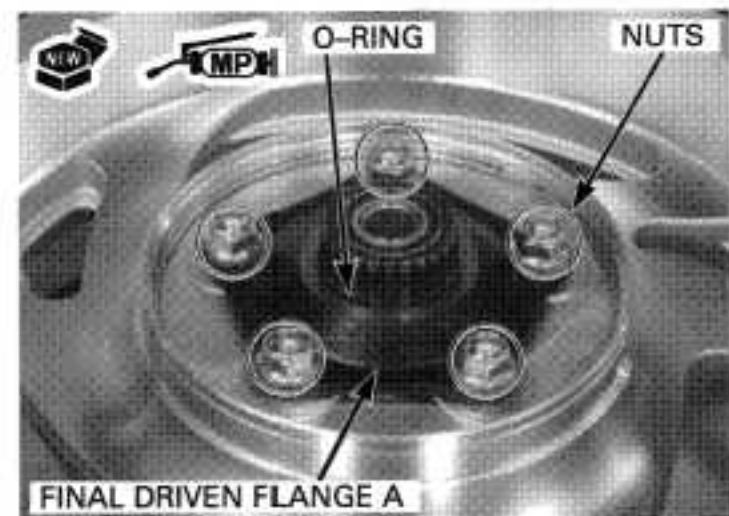

*Do not get grease on the brake disc or stopping power will be reduced.*

Install the brake disc onto the wheel hub. Install and tighten the new brake disc bolts to the specified torque.

**TORQUE: 42 N·m (4.3 kgf·m, 31 lbf·ft)**

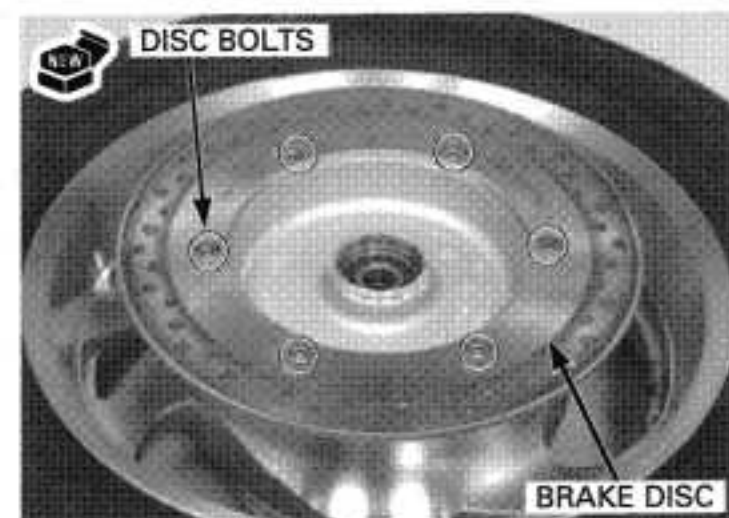



**WHEEL BALANCE**

- The wheel balance must be checked when the tire is remounted.
- For optimum balance, the tire balance mark (a paint dot on the side wall) must be located next to the mark on the wheel.
- Mount the tire with the arrow mark facing in the normal rotating direction.

*Wheel balance directly affects the stability, handling and overall safety of the motorcycle. Carefully check wheel balance before reinstalling the wheel.*

Mount the wheel, tire and brake disc assembly on an inspection stand.

Spin the wheel, allow it to stop, and mark the lowest (heaviest) part of the wheel with chalk.

Do this two or three times to verify the heaviest area. If the wheel is balanced, it will not stop consistently in the same position.

To balance the wheel, install balance weights on the lightest side of rim, the side opposite the chalk marks. Add just enough weight so the wheel will no longer stop in the same position when it is spun. Do not add more than 60 g (2.1 oz) to the wheel.

Apply grease to new dust seal lips and install the dust seals into both sides of the wheel until they are fully seated.

Apply grease to a new dust seal lip and install the dust seal into the wheel hub.

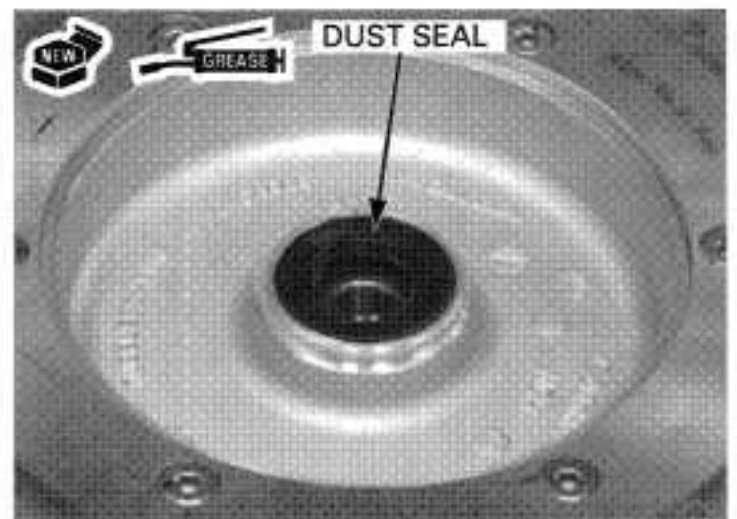
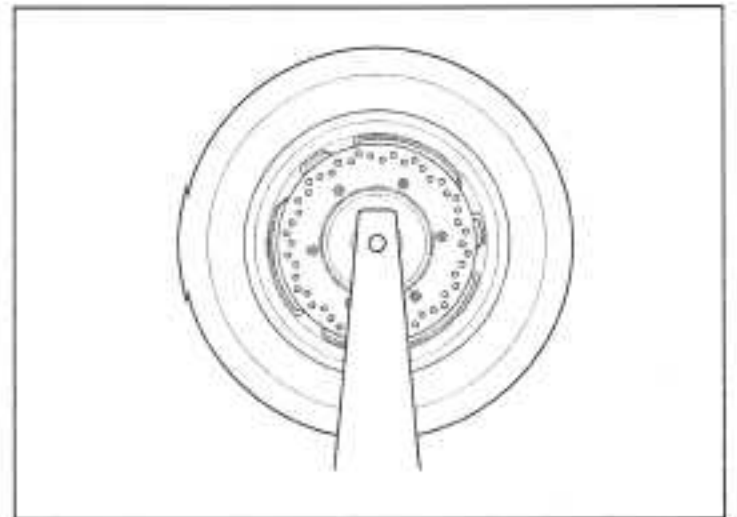
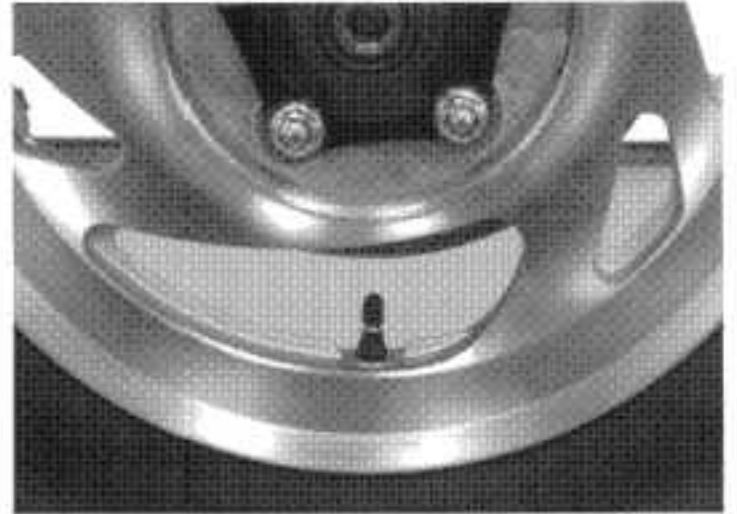

**INSTALLATION**

Install the collar to the right side of the rear wheel.

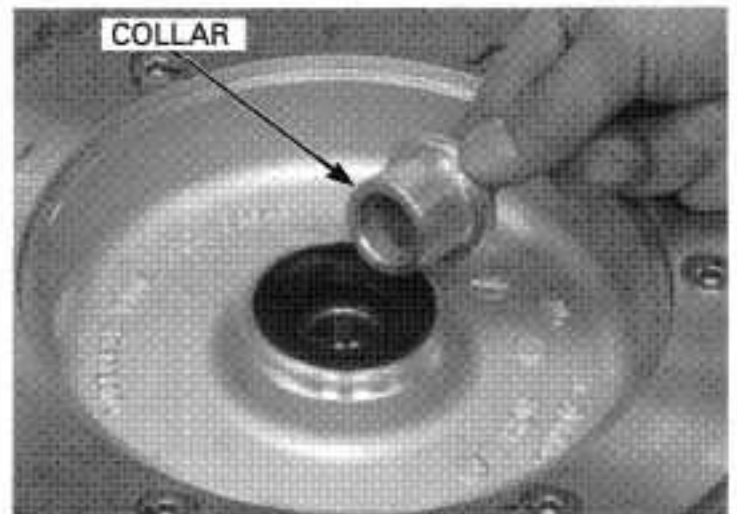



## REAR WHEEL/SUSPENSION

Apply 5 g (0.18 oz) of molybdenum disulfide paste to the joint surface of the final gear case splines and driven flange.

Engage the rear wheel with the final gear case, making sure the splines are correctly aligned.

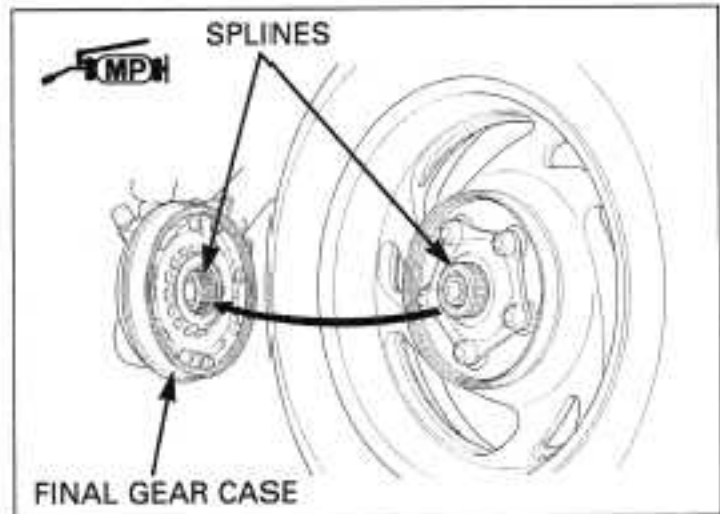

Install the rear brake caliper onto the brake disc.

Install the rear brake pads (page 15-11).



Insert the rear axle through the swingarm, rear brake caliper bracket, collar, hub and final gear case (from the left side).

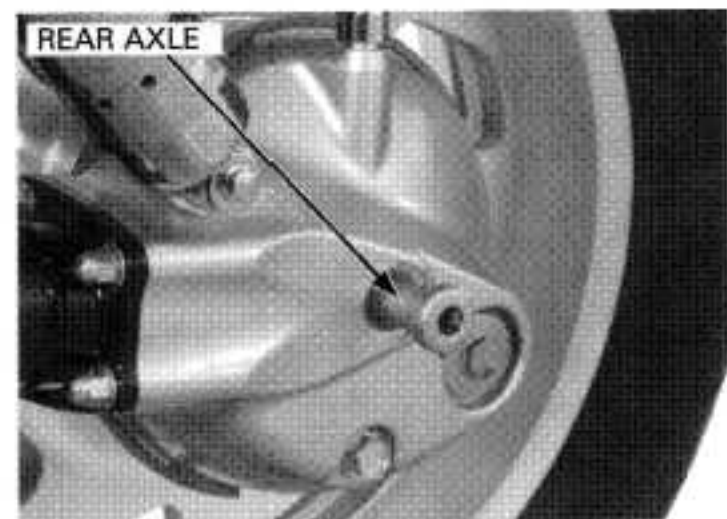

Install and tighten a new rear caliper stopper pin bolt to the specified torque.

**TORQUE: 69 N·m (7.0 kgf·m, 51 lbf·ft)**

Install and tighten the rear axle nut to the specified torque.

**TORQUE: 110 N·m (11.2 kgf·m, 81 lbf·ft)**

Operate the brake pedal several times.



If the final gear case was removed, tighten the gear case mounting nuts to the specified torque.

**TORQUE: 64 N·m (6.5 kgf·m, 47 lbf·ft)**

Tighten the rear muffler stay bolts and front muffler stay nuts to the specified torque.

**TORQUE: 34 N·m (3.5 kgf·m, 25 lbf·ft)**

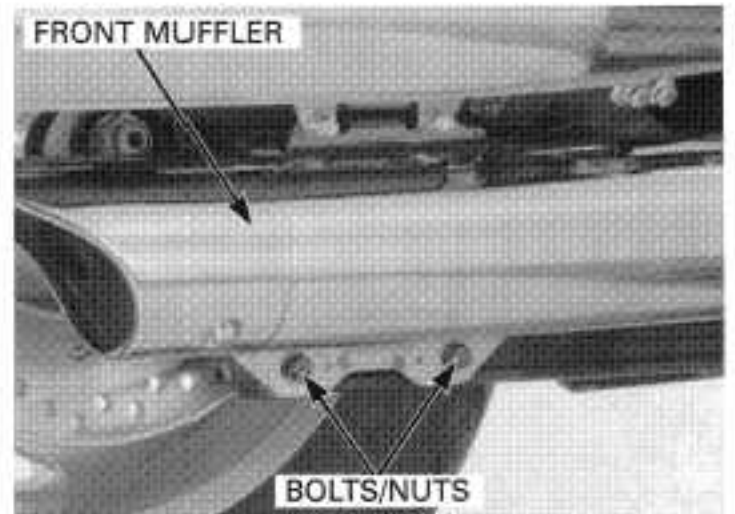

## SHOCK ABSORBER

### REMOVAL

Support the motorcycle securely using a hoist or equivalent.

*Right side only:* Loosen the front/rear muffler stay nuts and bolts. Make space to attach the shock absorber lower mounting bolt.

Remove the upper and lower mounting bolts, washer and shock absorber.

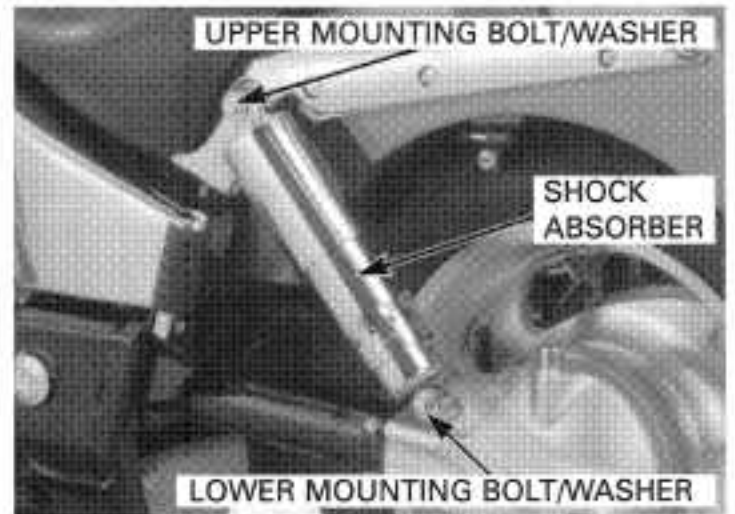

### INSPECTION

Visually inspect the shock absorber unit for damage.

Check for deformation or oil leaks.  
Check the rubber mounts for wear or damage.

Replace the shock absorber as an assembly if necessary.

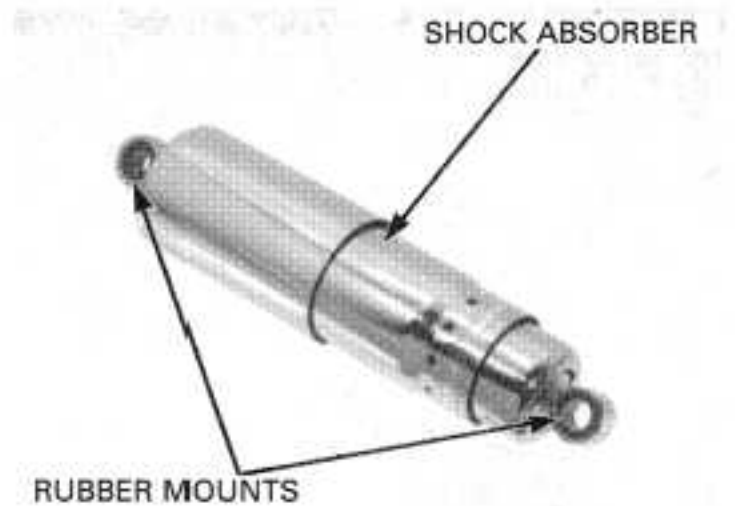

### INSTALLATION

*Left lower side only:* Install the washer, shock absorber, washer and lower mounting bolt.

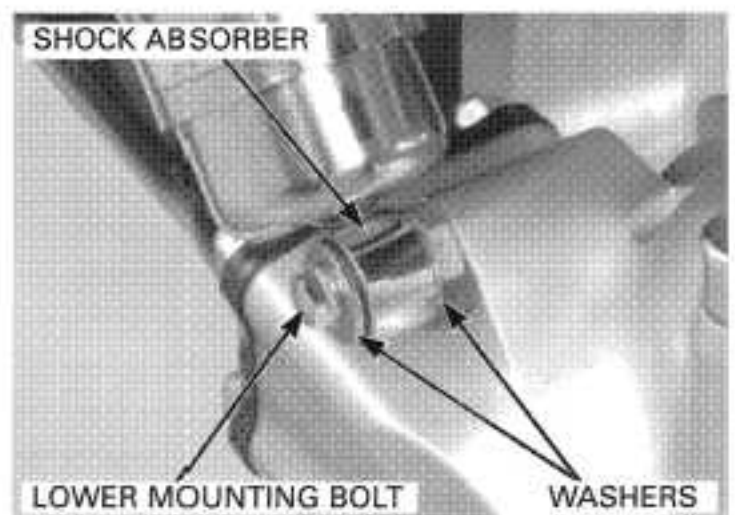

## REAR WHEEL/SUSPENSION

Install the shock absorber, washers and tighten the upper and lower mounting bolts to the specified torque.

**TORQUE: 26 N·m (2.7 kgf·m, 20 lbf·ft)**

*Right side only:* Tighten the rear muffler stay bolts and front muffler stay nuts to the specified torque.

**TORQUE: 34 N·m (3.5 kgf·m, 25 lbf·ft)**

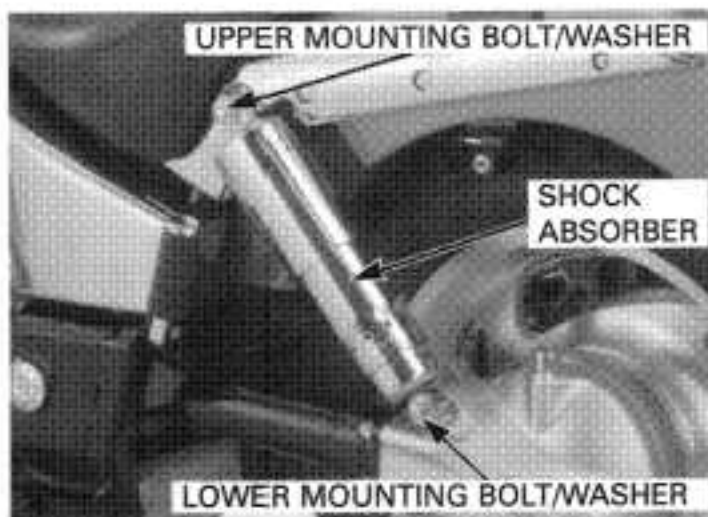

## SWINGARM

### REMOVAL

Remove the following:

- rear exhaust system (page 2-4)
- rear wheel (page 14-3)
- rear shock absorbers (page 14-11)
- final gear case (page 12-3)

Remove the bolts and rear brake hose clamps from the swingarm.

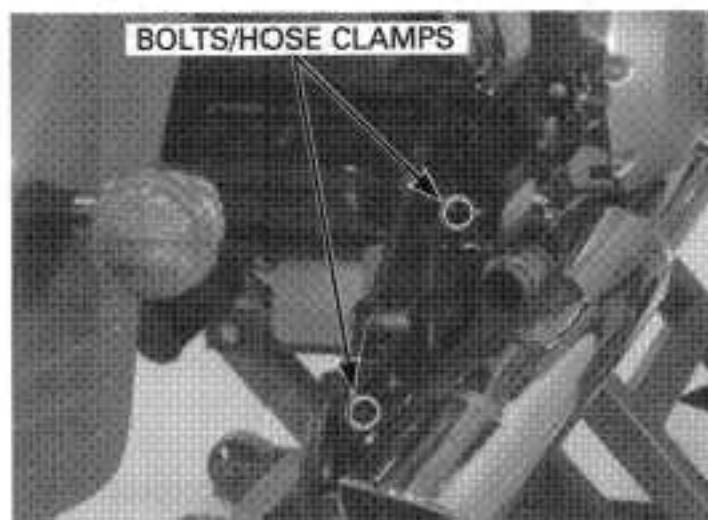

Remove the left and right swingarm pivot caps.

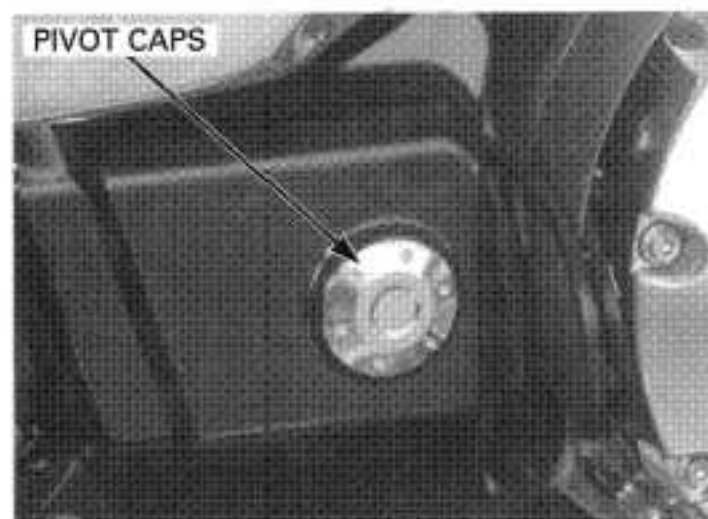

Loosen and remove the right pivot lock nut.

**TOOL:**

Lock nut wrench

07908-4690003

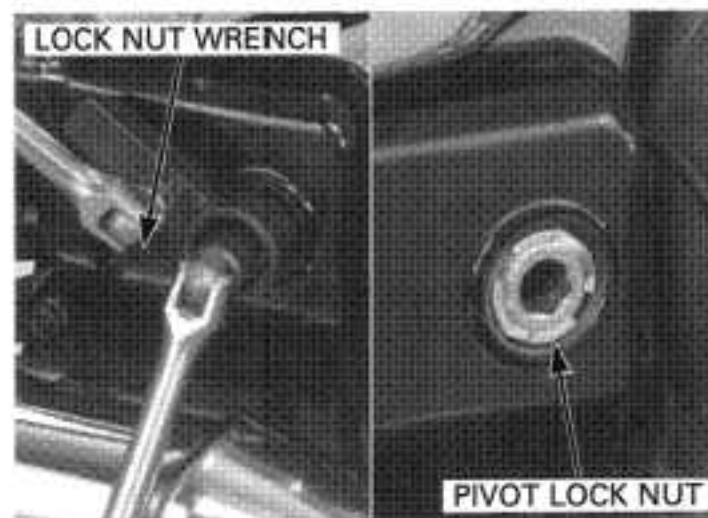

Loosen and remove the right pivot bolt.

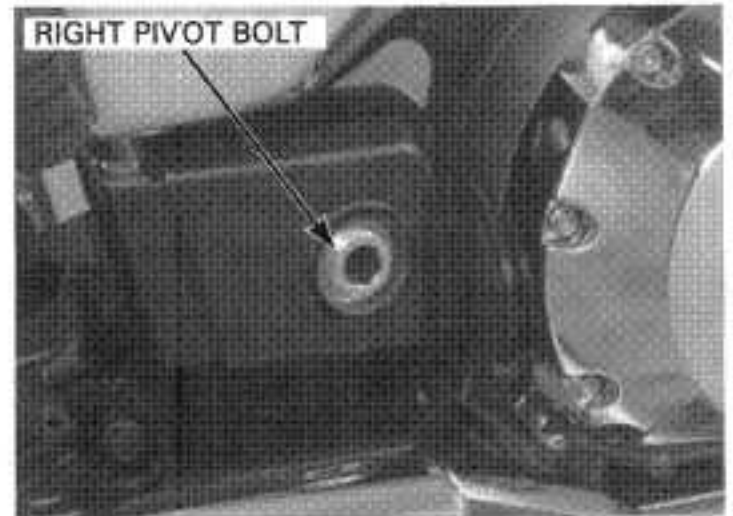

Loosen and remove the left pivot bolt, then remove the swingarm from the frame.

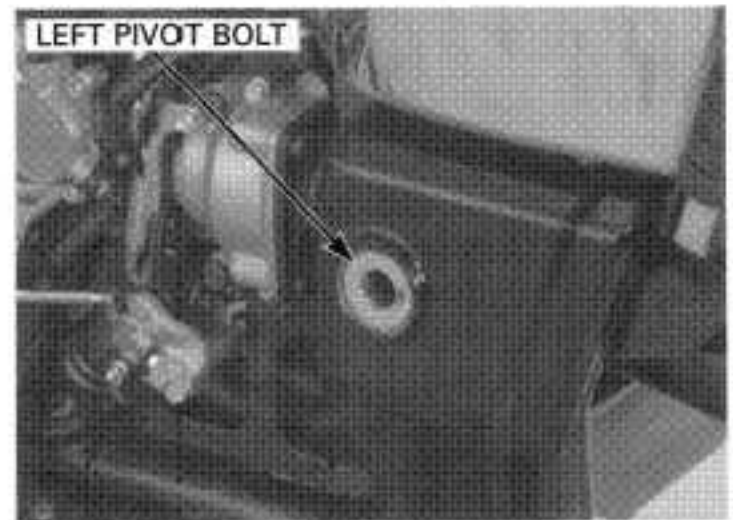

Remove the joint boot, universal joint and pivot bearings from the swingarm.

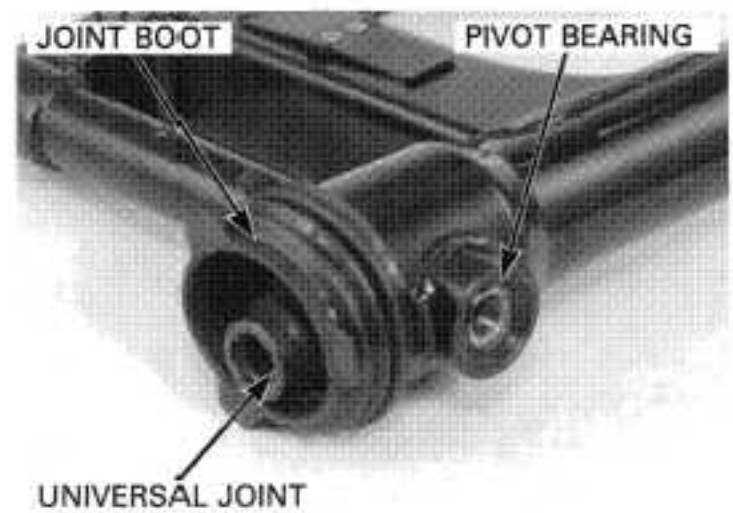

### INSPECTION

Check the bearing, dust seal and outer race for wear or damage.

Both bearings, outer races and grease retainer must be replaced as a set if any part is damaged or worn.

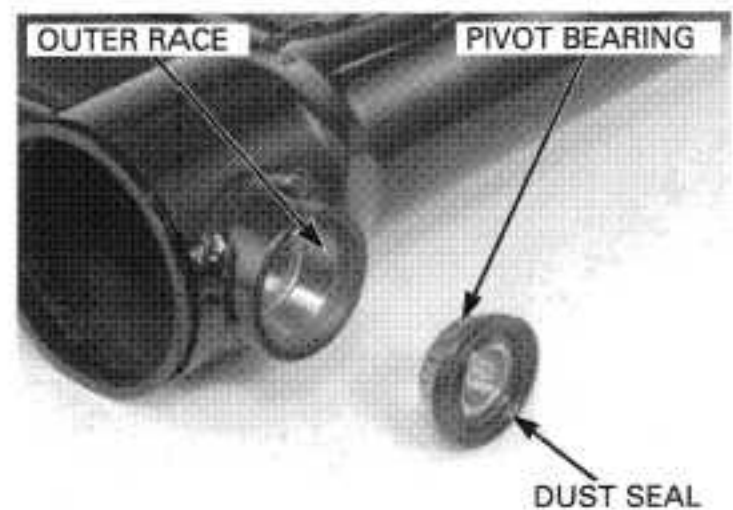



## REAR WHEEL/SUSPENSION

### PIVOT BEARING OUTER RACE REPLACEMENT

Punch or drill an appropriate hole into one grease retainer plate.  
Remove the outer race on the other side with the grease retainer plate.  
Remove the outer race with the grease retainer plate.

#### TOOLS:

##### Left bearing:

Pilot, 30mm

07746-0040700

Driver handle

07749-0010000

##### Right bearing:

Driver

07949-3710001

Pilot, 30mm

07746-0040700

Install new grease retainer plates and drive new bearing outer races into the swingarm pivots.

#### TOOLS:

Driver

07749-0010000

Attachment, 37 x 40 mm

07746-0010200

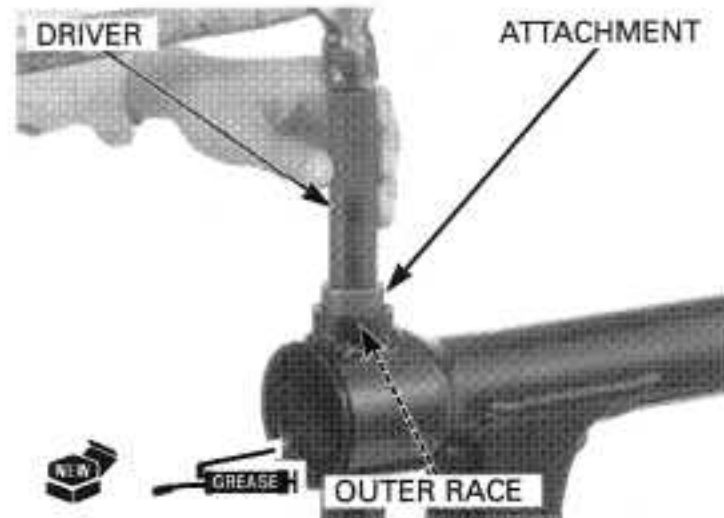
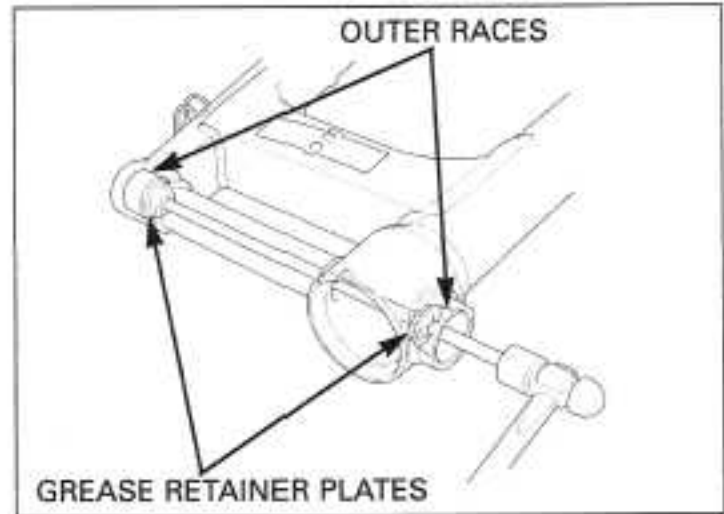

### INSTALLATION

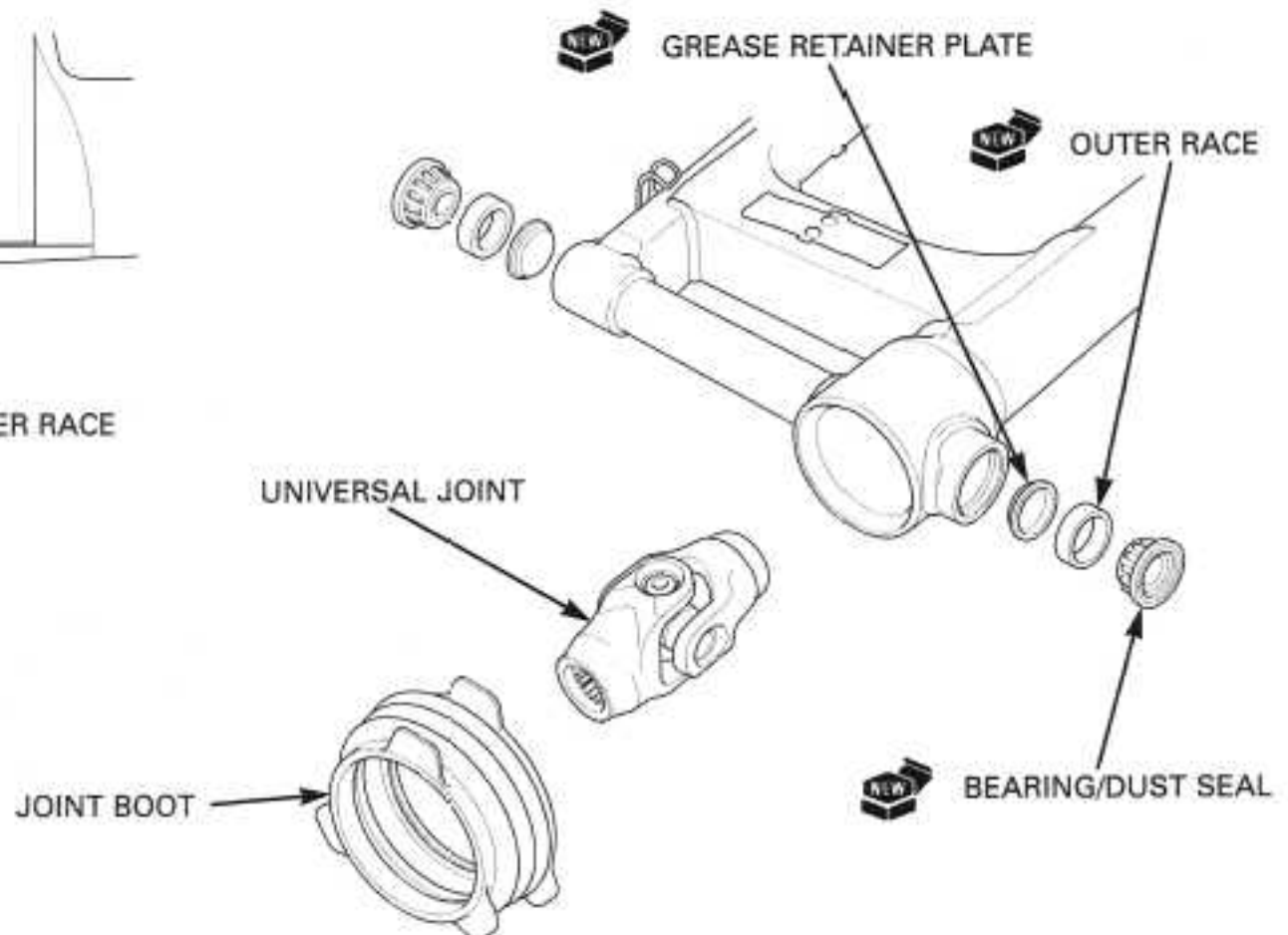
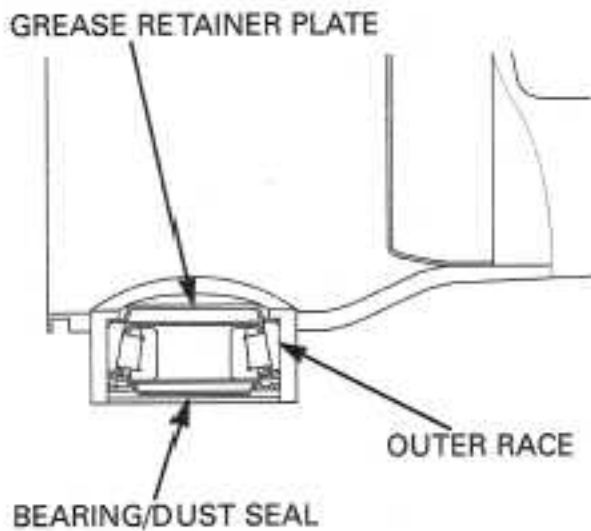



Pack grease into the bearing rollers and dust seal lips. Install the bearings/dust seals into the swingarm pivot.

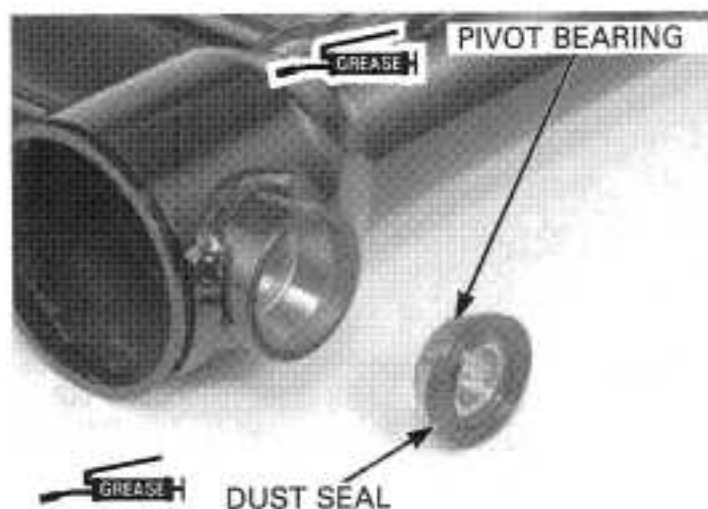

Apply molybdenum disulfide grease to the universal joint spline of the engine side and place the universal joint into the swingarm.



Remove the left crankcase rear cover (page 2-3).

Install the swingarm into the frame.  
Align the frame pivot bolt hole with the hole in the swingarm.  
Install the left swingarm pivot bolt and finger-tighten it.

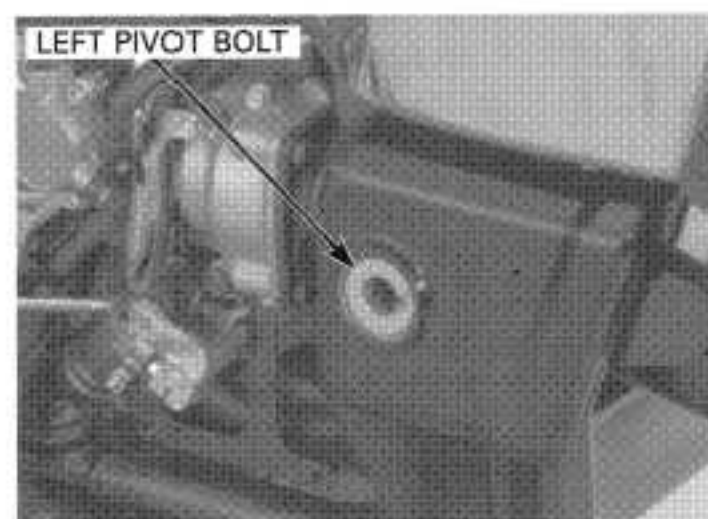

Align the frame pivot bolt hole with the hole in the swingarm.  
Install the right swingarm pivot bolt and finger-tighten it.

Install the right swingarm pivot lock nut and finger-tighten it.  
Then move the swingarm up and down and afterward, tighten the bolts to the specified torque.

**TORQUE:**

Right swingarm pivot bolt:  
14 N·m (1.4 kgf·m, 10 lbf·ft)

Left swingarm pivot bolt:  
103 N·m (10.5 kgf·m, 76 lbf·ft)

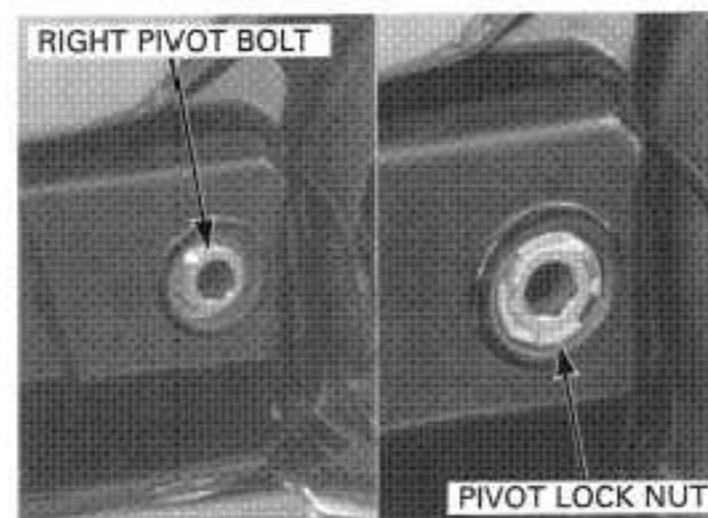

## REAR WHEEL/SUSPENSION

Refer to torque wrench reading information on page 14-1 "Service Information".

Tighten the right swingarm pivot lock nut while holding the right swingarm pivot bolt.

**TOOL:**

**Lock nut wrench**

**07908-4690003**

**TORQUE: Actual: 113 N·m (11.5 kgf·m, 83 lbf·ft)**

**Indicate: 103 N·m (10.5 kgf·m, 76 lbf·ft)**

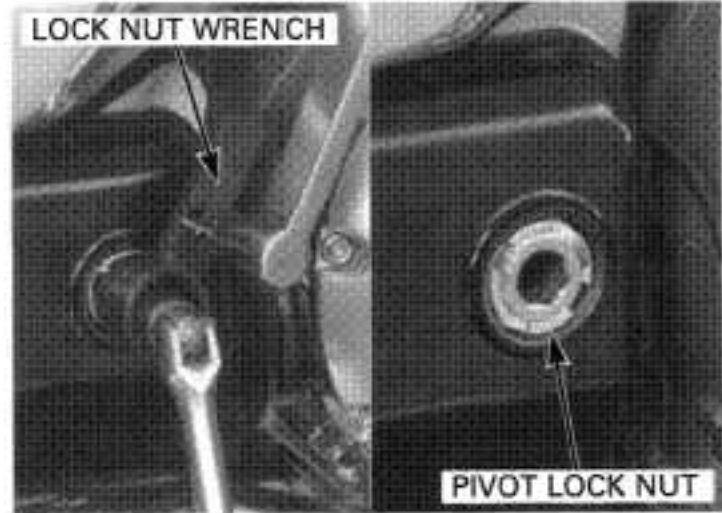

Remove the drive shaft from the final gear case (page 12-3).

Engage the universal joint splines with the output driven gear shaft splines using the drive shaft as shown.

Reinstall the drive shaft into the final gear case (page 12-18).

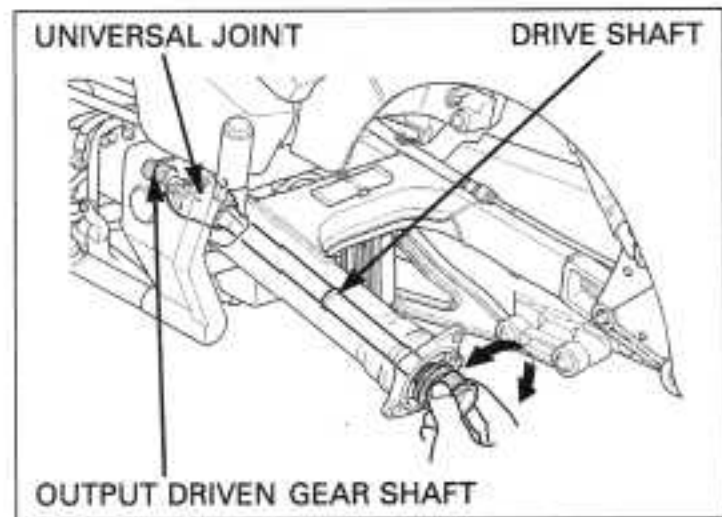

Install the joint boot over the output gear case securely.

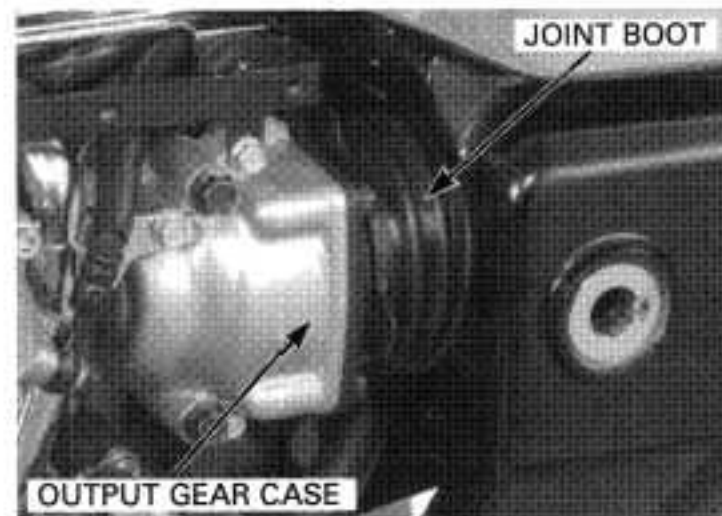

Install the left and right swingarm pivot caps.

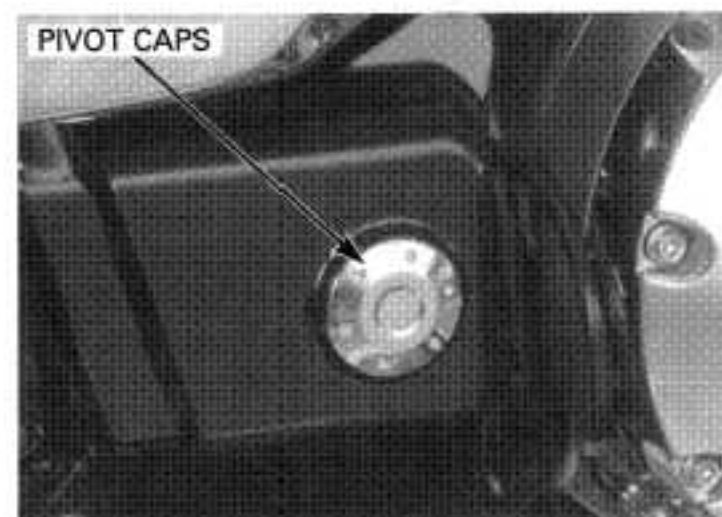

Install the brake hose clamps to the swingarm and tighten the clamp bolts to the specified torque.

**TORQUE: 12 N·m (1.2 kgf·m, 9 lbf·ft)**

Install the following:

- left crankcase rear cover (page 2-3)
- final gear case (page 12-18).
- rear shock absorber (page 14-11)
- rear wheel (page 14-9)
- rear exhaust system (page 2-5)

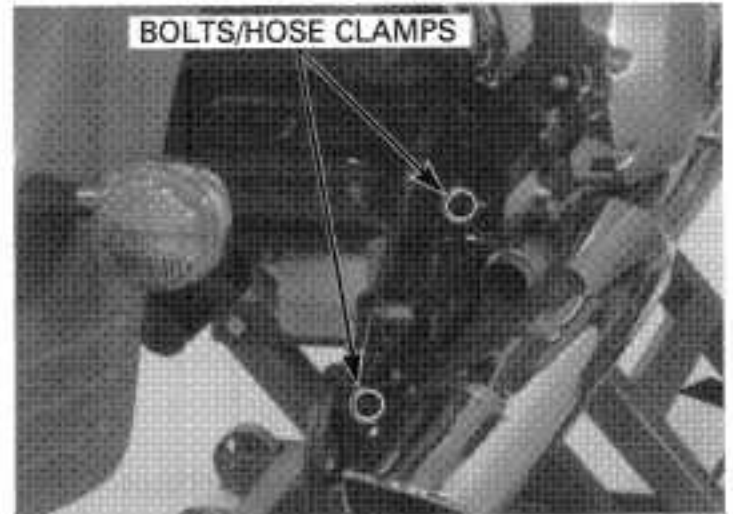

# HYDRAULIC BRAKE

---

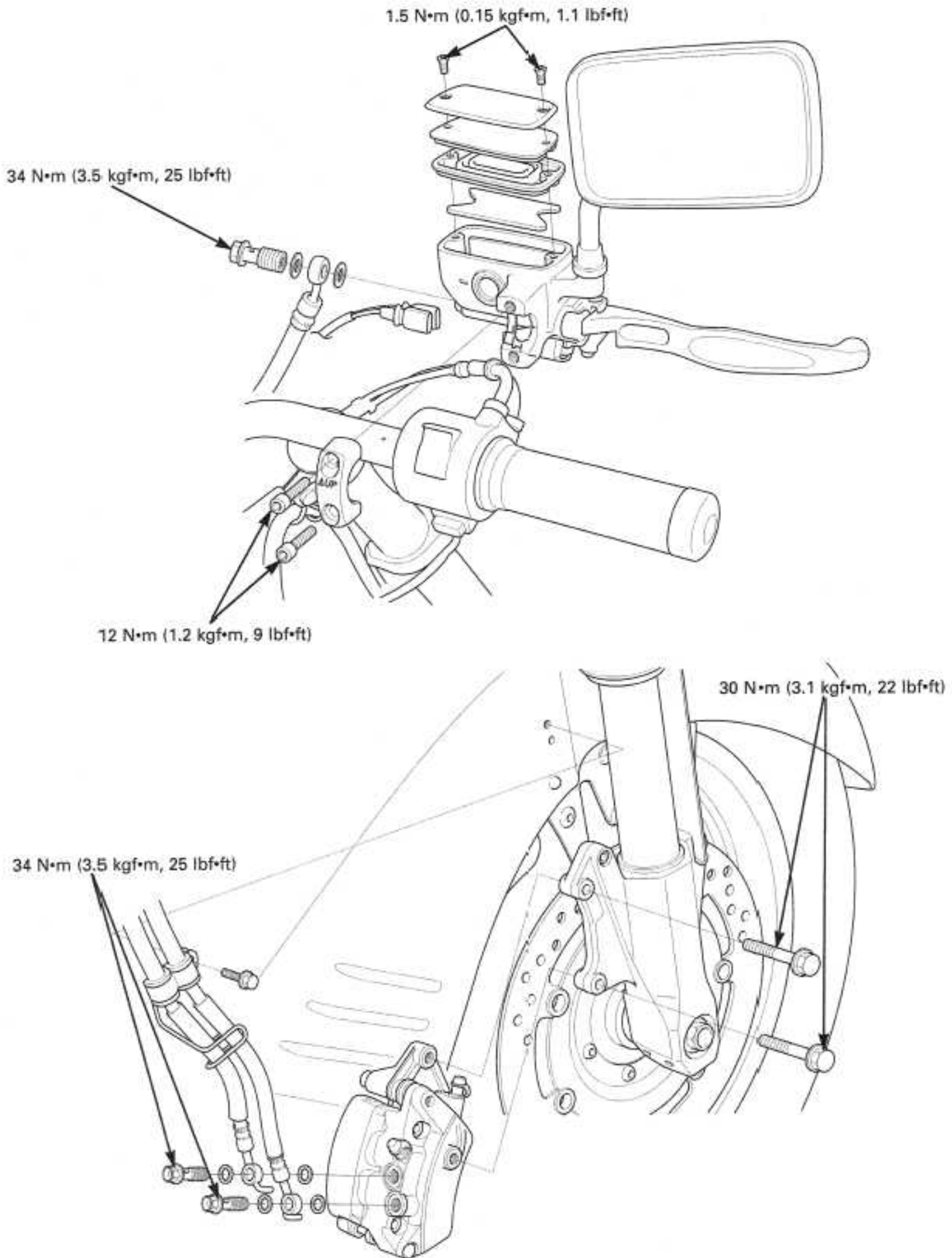

# 15. HYDRAULIC BRAKE

SERVICE INFORMATION	15-2	FRONT CALIPER	15-17
TROUBLESHOOTING	15-3	REAR MASTER CYLINDER	15-21
BRAKE FLUID REPLACEMENT/ AIR BLEEDING	15-4	REAR CALIPER	15-28
BRAKE PAD/DISC	15-10	PCV (Proportional Control Valve)	15-31
FRONT MASTER CYLINDER	15-12		

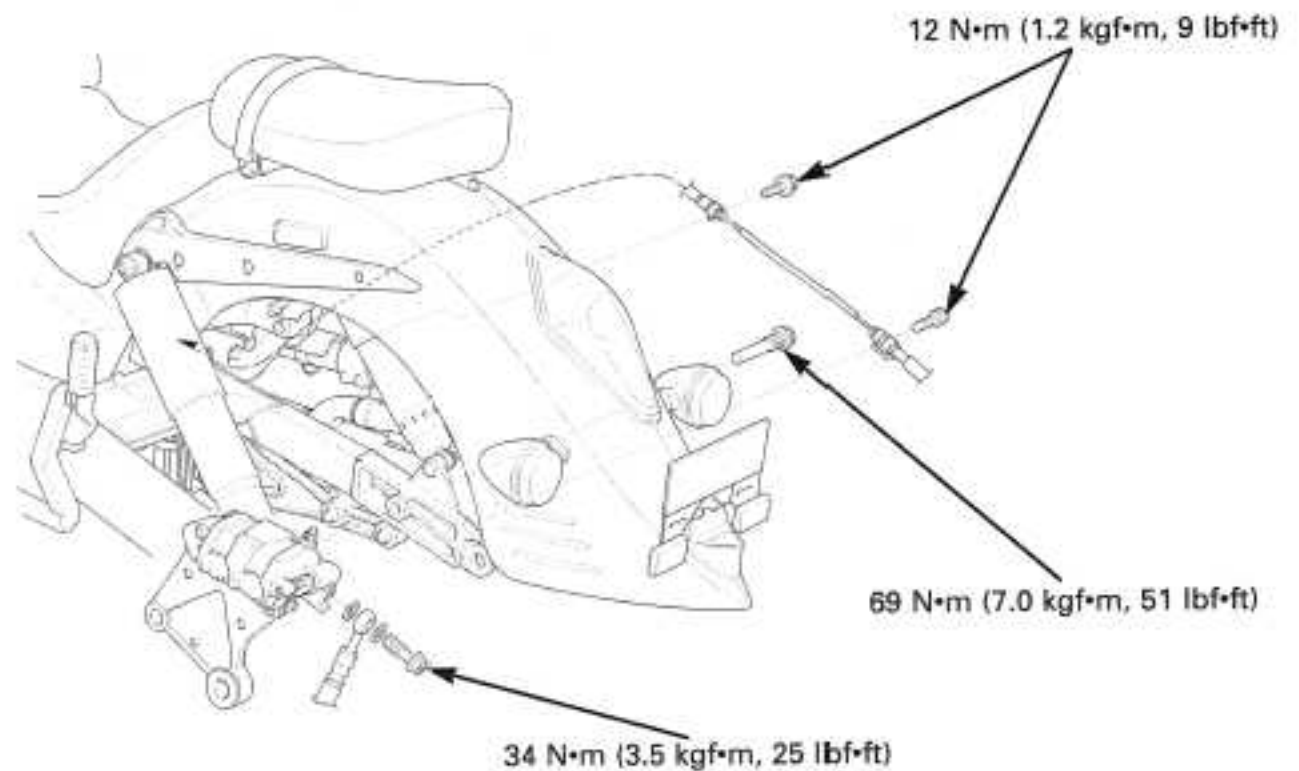
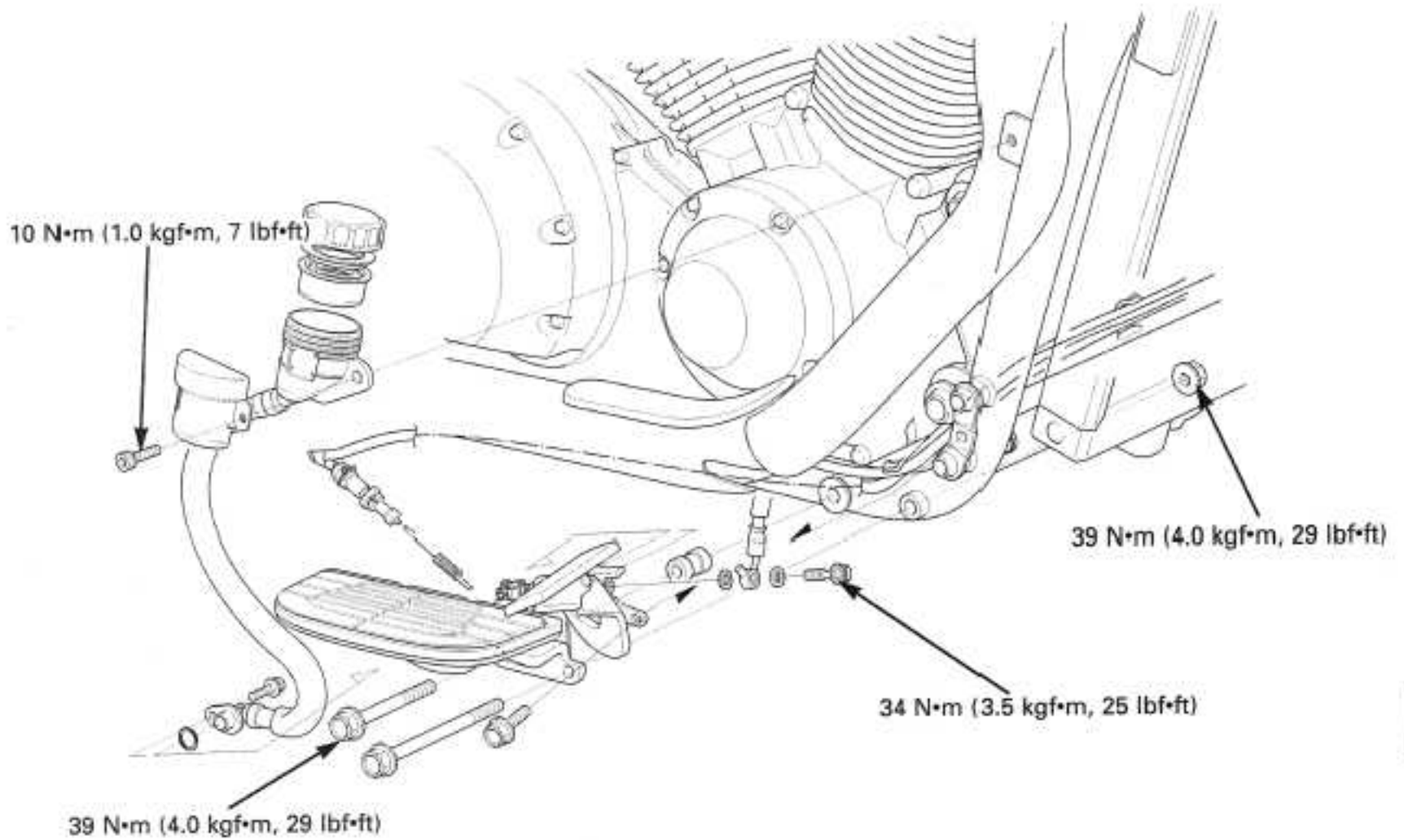



## HYDRAULIC BRAKE

### SERVICE INFORMATION

#### GENERAL

#### ⚠ CAUTION

Frequent inhalation of brake pad dust, regardless of material composition could be hazardous to your health.

- Avoid breathing dust particles.
- Never use an air hose or brush to clean brake assemblies. Use an OSHA-approved vacuum cleaner.

- A contaminated brake disc or pad reduces stopping power. Discard contaminated pads and clean a contaminated disc with a high quality brake degreasing agent.
- Avoid spilling brake fluid on painted, plastic or rubber parts. Place a rag or shop towel over these parts whenever the system is serviced.
- Be careful whenever you remove the reservoir cap; make sure the reservoir is horizontal.
- When servicing the rear hydraulic system, do not leave the bleed valve or oil bolt loosened for a long time (approximately 10 – 15 minutes or more) with the reservoir cap removed. It will cause the brake fluid to overflow from the reservoir and damage the painted, plastic or rubber parts.
- Bleed the hydraulic system if it has been disassembled or if the brake feels spongy.
- Never allow contaminants (dirt, water, etc.) to get into an open reservoir.
- Always use fresh DOT 4 brake fluid from a sealed container when servicing the system. Do not mix different types of fluid as they may not be compatible.
- Always check the brake operation before riding the motorcycle.

#### SPECIFICATION

##### HYDRAULIC BRAKE

Unit: mm (in)

ITEM		STANDARD	SERVICE LIMIT	
Front	Specified brake fluid	DOT 4	—	
	Brake disc thickness	4.5 (0.18)	3.5 (0.14)	
	Brake disc runout	—	0.30 (0.012)	
	Master cylinder I.D.	14.000 – 14.043 (0.5512 – 0.5529)	14.055 (0.5533)	
	Master piston O.D.	13.957 – 13.984 (0.5495 – 0.5506)	13.94 (0.549)	
	Right caliper cylinder I.D.	A	22.650 – 22.700 (0.8917 – 0.8937)	22.710 (0.8941)
		B	27.000 – 27.050 (1.0630 – 1.0650)	27.060 (1.0654)
	Right caliper piston O.D.	A	22.585 – 22.618 (0.8892 – 0.8905)	22.560 (0.8882)
		B	26.935 – 26.968 (1.0604 – 1.0617)	26.910 (1.0594)
	Left caliper cylinder I.D.	A	22.650 – 22.700 (0.8917 – 0.8937)	22.710 (0.8941)
		B	25.400 – 25.450 (1.0000 – 1.0020)	25.460 (1.0024)
Left caliper piston O.D.	A	22.585 – 22.618 (0.8892 – 0.8905)	22.560 (0.8882)	
	B	25.335 – 25.368 (0.9974 – 0.9967)	25.320 (0.9968)	
Rear	Specified brake fluid	DOT 4	—	
	Brake pedal height	65.0 ± 1.0 (2.56 ± 0.03)	—	
	Brake disc thickness	7.0 (0.28)	6.0 (0.24)	
	Brake disc runout	—	0.30 (0.012)	
	Master cylinder I.D.	17.460 – 17.503 (0.6874 – 0.6891)	17.515 (0.6896)	
	Master piston O.D.	17.417 – 17.444 (0.6857 – 0.6868)	17.405 (0.6852)	
	Caliper cylinder I.D.	33.960 – 34.010 (1.3370 – 1.3390)	34.020 (1.3394)	
	Caliper piston O.D.	33.878 – 33.928 (1.3338 – 1.3357)	33.870 (1.3335)	

**TORQUE VALUES**

Brake pad pin	18 N•m (1.8 kgf•m, 13 lbf•ft)	
Brake caliper bleed valve	6 N•m (0.6 kgf•m, 4.3 lbf•ft)	
Brake hose oil bolt	34 N•m (3.5 kgf•m, 25 lbf•ft)	
Brake pipe joint bolt	17 N•m (1.7 kgf•m, 12 lbf•ft)	Apply oil to the threads and flange surface.
Brake pipe 2/3 way joint	12 N•m (1.2 kgf•m, 9 lbf•ft)	
Brake hose clamp/stay bolt	12 N•m (1.2 kgf•m, 9 lbf•ft)	
Brake hose guide bolt	21 N•m (2.1 kgf•m, 15 lbf•ft)	ALOC bolt: replace with new one.
PCV (Proportional Control Valve) mounting bolt	12 N•m (1.2 kgf•m, 9 lbf•ft)	
Front master cylinder holder bolt	12 N•m (1.2 kgf•m, 9 lbf•ft)	
Front master cylinder reservoir cap screw	1.5 N•m (0.15 kgf•m, 1.1 lbf•ft)	
Front brake lever pivot bolt	1 N•m (0.1 kgf•m, 0.7 lbf•ft)	
Front brake lever pivot nut	6 N•m (0.6 kgf•m, 4.3 lbf•ft)	
Front brake light switch screw	1.2 N•m (0.12 kgf•m, 0.9 lbf•ft)	
Rear master cylinder reservoir cover bolt	10 N•m (1.0 kgf•m, 7 lbf•ft)	
Rear master cylinder reservoir hose joint screw	1.5 N•m (0.15 kgf•m, 1.1 lbf•ft)	Apply locking agent to the threads.
Rear master cylinder mounting bolt	12 N•m (1.2 kgf•m, 9 lbf•ft)	
Rear master cylinder push rod lock nut	18 N•m (1.8 kgf•m, 13 lbf•ft)	
Front caliper mounting bolt	30 N•m (3.1 kgf•m, 22 lbf•ft)	ALOC bolt: replace with new one.
Front caliper body B bolt	23 N•m (2.3 kgf•m, 17 lbf•ft)	ALOC bolt: replace with new one.
Front caliper pin bolt A	23 N•m (2.3 kgf•m, 17 lbf•ft)	Apply locking agent to the threads.
Front caliper pin bolt	13 N•m (1.3 kgf•m, 9 lbf•ft)	Apply locking agent to the threads.
Rear caliper pin bolt	27 N•m (2.8 kgf•m, 20 lbf•ft)	
Rear caliper bracket pin bolt	23 N•m (2.3 kgf•m, 17 lbf•ft)	Apply locking agent to the threads.
Rear caliper stopper pin bolt	69 N•m (7.0 kgf•m, 51 lbf•ft)	ALOC bolt: replace with new one.
Brake pedal pivot bolt	21 N•m (2.1 kgf•m, 15 lbf•ft)	

**TOOL**

Snap ring pliers 07914-SA50001

**TROUBLESHOOTING**

**Brake lever/pedal soft or spongy**

- Air in hydraulic system
- Leaking hydraulic system
- Contaminated brake pad/disc
- Worn caliper piston seal
- Worn master cylinder piston cup
- Worn brake pad/disc
- Contaminated caliper
- Caliper not sliding properly
- Low brake fluid level
- Clogged fluid passage
- Warped/deformed brake disc
- Sticking/worn caliper piston
- Sticking/worn master cylinder piston
- Contaminated master cylinder
- Bent brake lever/pedal

**Brake lever/pedal hard**

- Clogged/restricted brake system
- Sticking/worn caliper piston
- Caliper not sliding properly
- Clogged/restricted fluid passage
- Worn caliper piston seal
- Sticking/worn master cylinder piston
- Bent brake lever/pedal

**Brake drag**

- Contaminated brake pad/disc
- Misaligned wheel
- Badly worn brake pad/disc
- Warped/deformed brake disc
- Caliper not sliding properly
- Clogged/restricted fluid passage
- Sticking/worn caliper piston

# BRAKE FLUID REPLACEMENT/ AIR BLEEDING

*A contaminated brake disc or pad reduces stopping power. Discard contaminated pads and clean a contaminated disc with a high quality brake degreasing agent.*

*Do not allow foreign material to enter the system when filling the reservoir. Avoid spilling brake fluid on painted, plastic or rubber parts. Place a rag over these parts whenever the system is serviced.*

Once the hydraulic system has been opened, or if the brake feels spongy, the system must be bled. When using a commercially available brake bleeder, follow the manufacturer's operating instructions.

### BRAKE FLUID DRAINING

Make sure the master cylinder is parallel to the ground, before removing the reservoir cover.

#### FRONT:

Turn the handlebar to the left until the reservoir is level.

Remove the screws, reservoir cap, diaphragm plate, diaphragm and float.

Connect a bleed hose to the upper bleed valve.

Loosen the upper bleed valve and pump the brake lever.

Stop operating the brake when fluid stops flowing out of the upper bleed valve.

#### REAR (LINKED):

Remove bolt and the reservoir cover.

Install the bolt.

Remove the reservoir cap, diaphragm plate and diaphragm.

Connect a bleed hose to the front caliper lower bleed valve.

Loosen the front caliper lower bleed valve and pump the brake lever.

Stop operating the brake when fluid stops flowing out of the front caliper lower bleed valve.

Tighten the front caliper lower bleed valve securely.

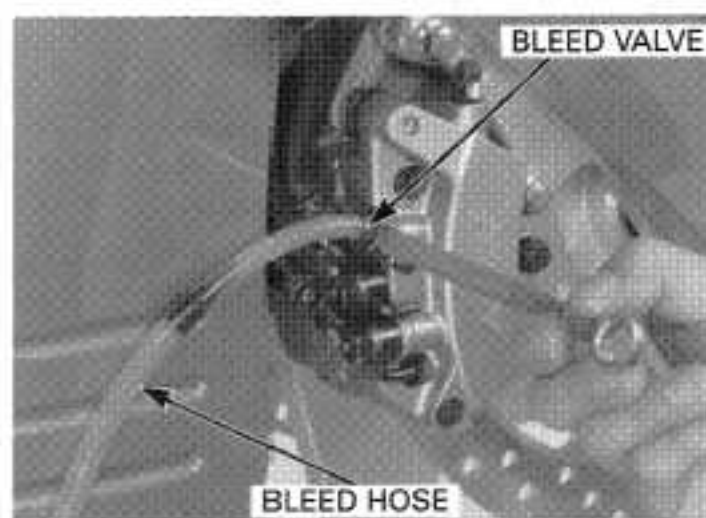
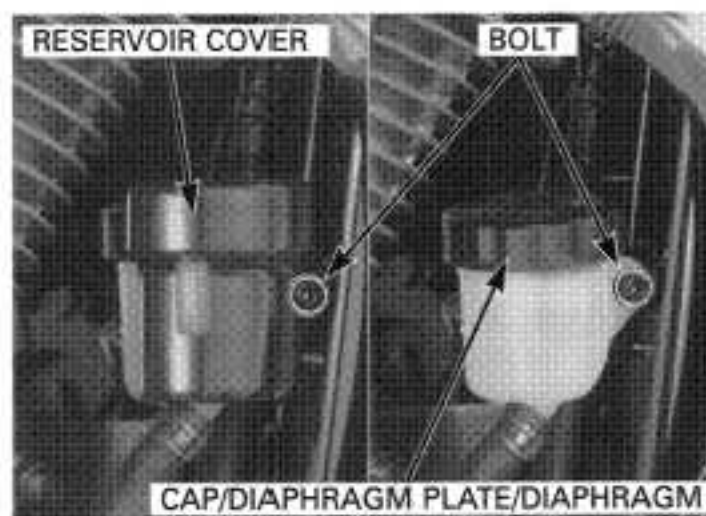
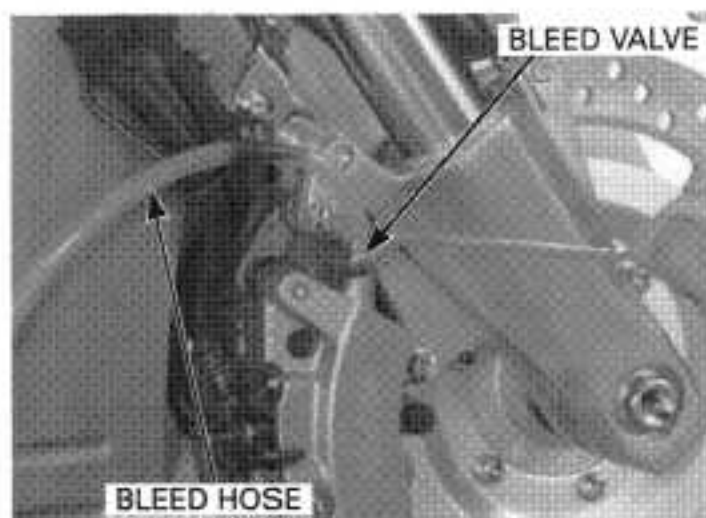
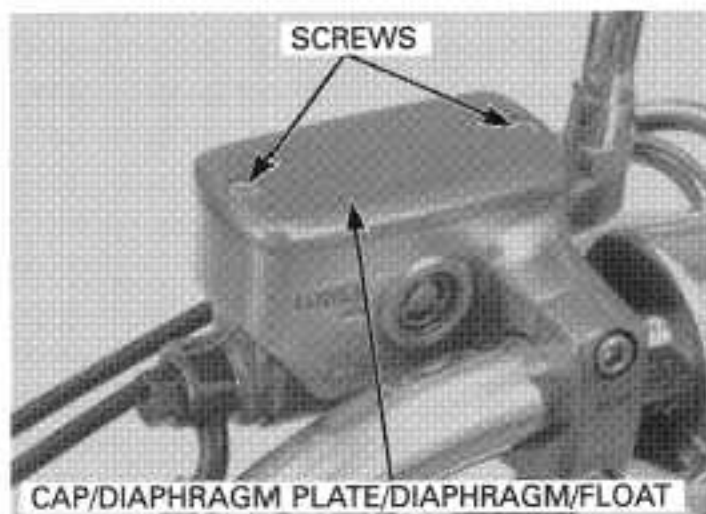

Connect a bleed hose to the rear caliper bleed valve.

In the same manner as at the caliper bleed valve (above procedure), drain the brake fluid from the rear caliper bleed valve.

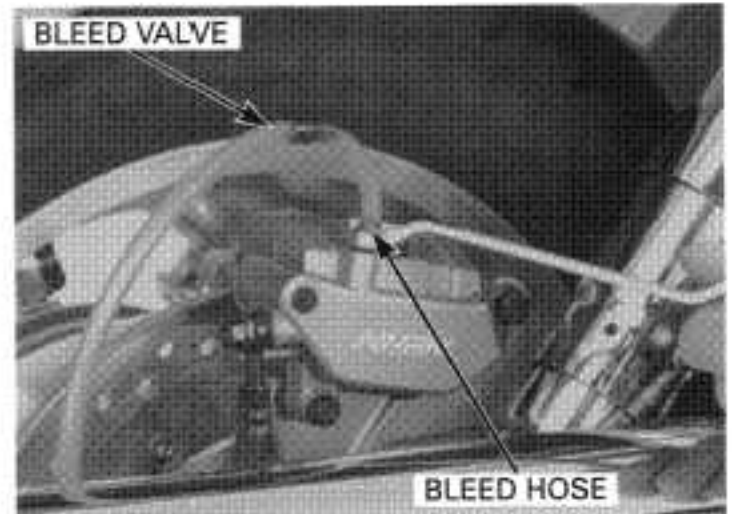

### BRAKE FLUID FILLING/AIR BLEEDING

#### BRAKE FLUID LINE

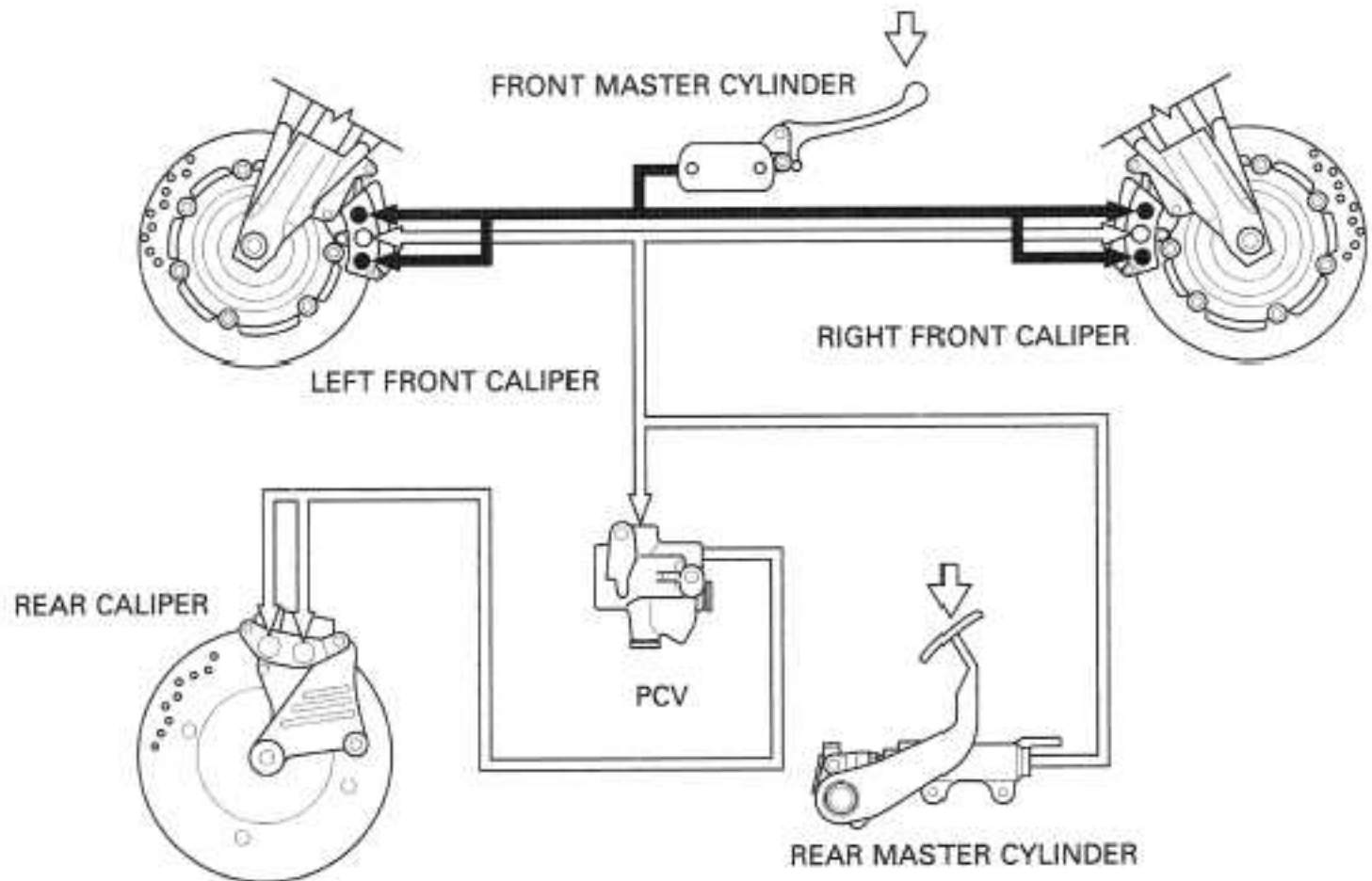

*Do not mix different types of fluid since they are not compatible.*

**FRONT:**  
Fill the master cylinder with DOT 4 brake fluid to the upper level.

Connect a commercially available brake bleeder to the front caliper upper bleed valve.

Check the fluid level often while bleeding the brakes to prevent air from being pumped into the system. When using a brake bleeding tool, follow the manufacturer's operating instructions.

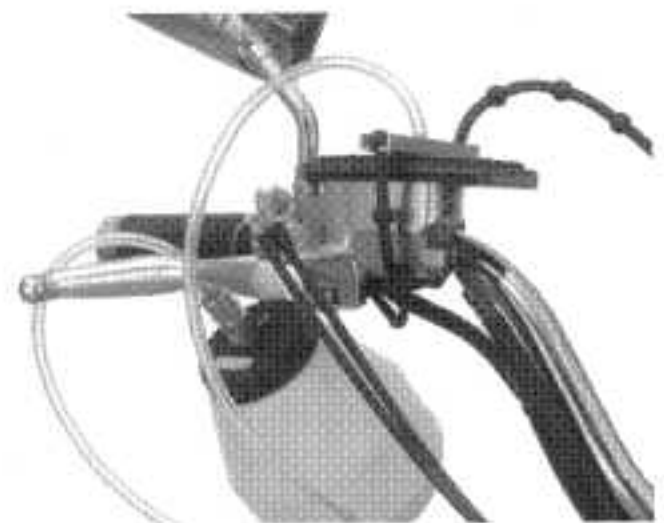



## HYDRAULIC BRAKE

*If air enters the bleeder from around the bleed valve threads, seal the threads with Teflon tape.*

Pump the brake bleeder and loosen the front caliper upper bleed valve. Add fluid when the fluid level in the master cylinder is low to prevent drawing air into the system.

Repeat the above procedures until no air bubbles appear in the plastic hose.

Close the front caliper upper bleed valve and operate the front brake lever.

If the lever is still spongy, bleed the system again.

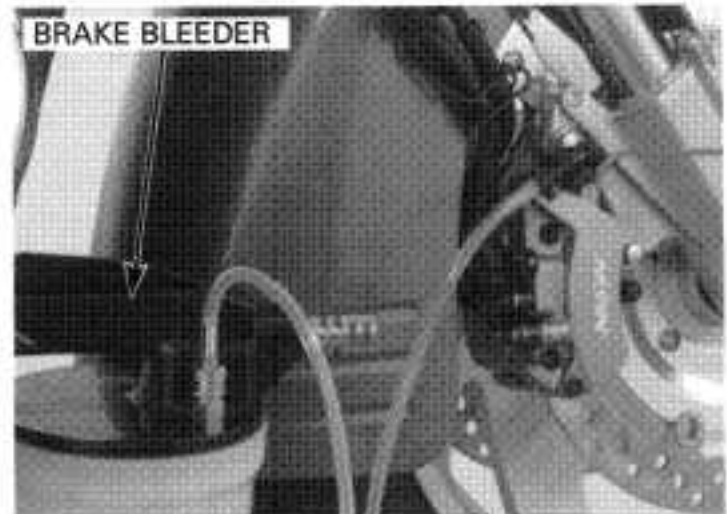

If a brake bleeder is not available, perform the following procedure.

Pressurize the system with the lever until there are no air bubbles in the fluid flowing out of the reservoir small hole and lever resistance is felt.

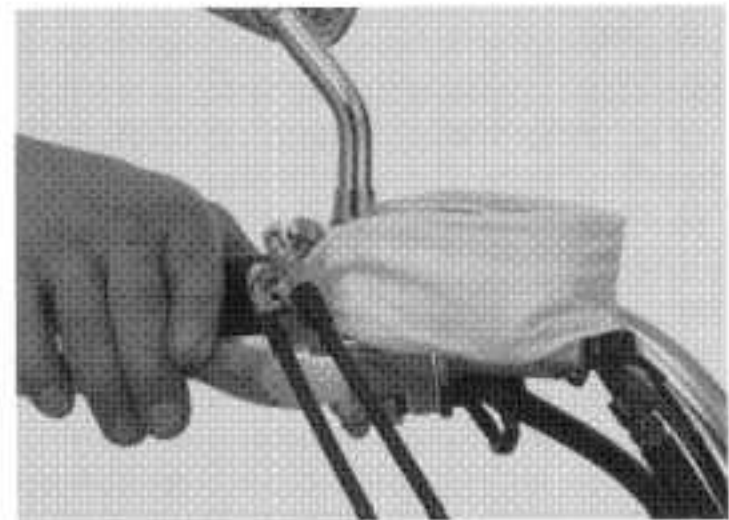

*Do not release the brake lever until the bleed valve has been closed.*

1. Pump the brake lever several times, then squeeze the brake lever all the way and loosen the bleed valve 1/4 of a turn. Wait several seconds and close the bleed valve.

2. Release the brake lever slowly until the bleed valve has been closed.

3. Repeat steps 1 – 2 until there are no air bubbles in the bleed hose.

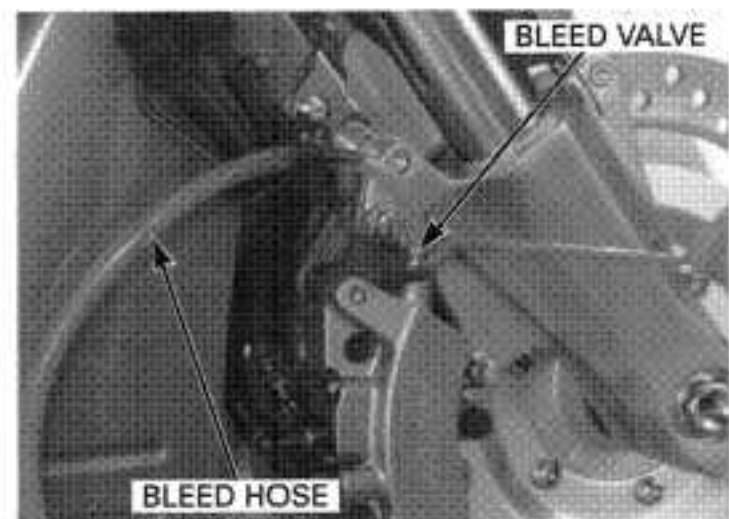

After bleeding the fluid completely, tighten the bleed valves to the specified torque.

**TORQUE: 6 N·m (0.6 kgf·m, 4.3 lbf·ft)**

Fill the reservoir to the casting ledge with DOT 4 brake fluid to the upper level.

Install the diaphragm, set plate and reservoir cap.

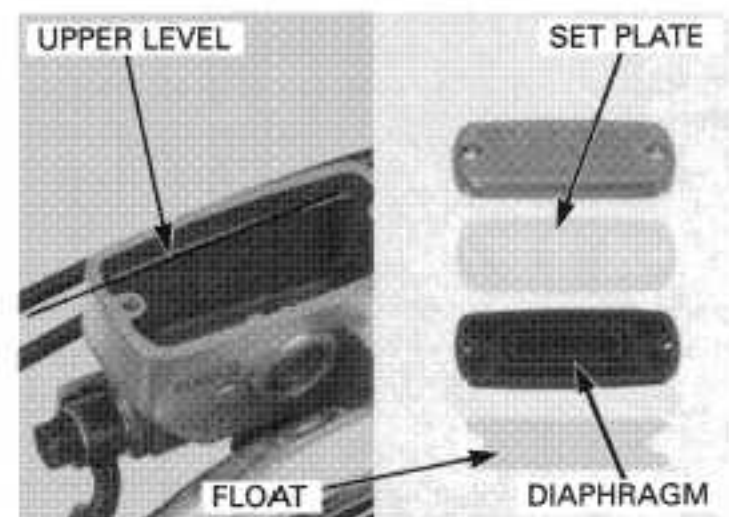



Tighten the screws to the specified torque.

**TORQUE: 1.5 N·m (0.15 kgf·m, 1.1 lbf·ft)**

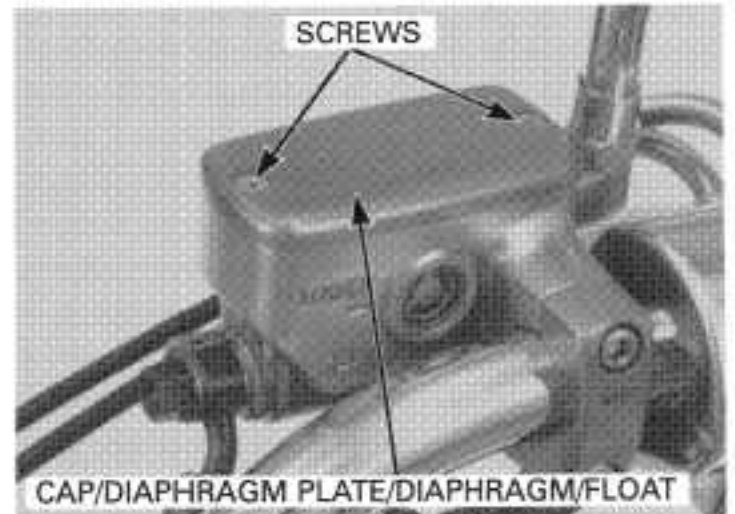

**REAR (LINKED):  
FLUID FEEDING**

Add fluid and bleed any air from the brake pedal line in the sequence as follow:

1. Right front caliper lower bleed valve
2. Left front caliper lower bleed valve
3. Rear caliper bleed valve

Fill the rear master cylinder with DOT 4 brake fluid to the upper level.

Operate the brake pedal several times to bleed any air from the master cylinder.

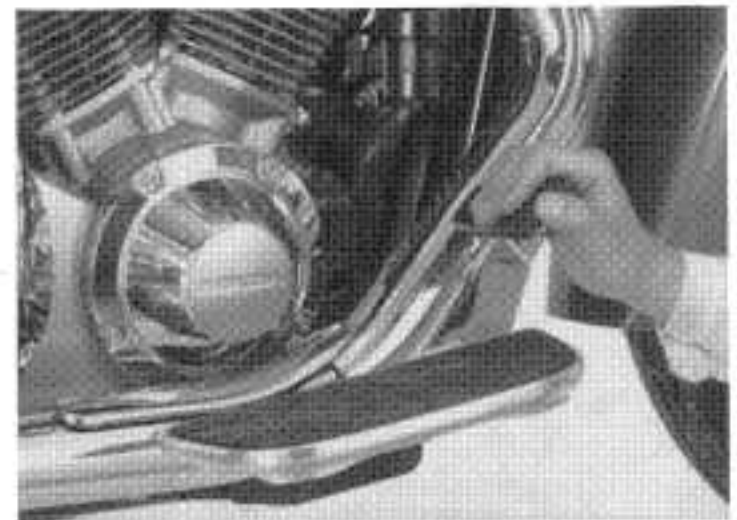

- (1) Connect a commercially available brake bleeder to the front caliper lower bleed valve.



*If air enters the bleeder from around the bleed valve threads, seal the threads with teflon tape.*

1. Pump the brake bleeder and loosen the front caliper lower bleed valve. Add fluid when the fluid level in the master cylinder is low to prevent drawing air into the system.
2. Repeat the above procedures until a sufficient amount of fluid flows out of the caliper lower bleed valve.

It is not a problem if the fluid flowing out from the lower bleed valve contains air bubbles because the lines will be bled later.



## HYDRAULIC BRAKE

- (2) Connect a commercially available brake bleeder to the rear caliper bleed valve.  
Repeat steps 1 and 2 for rear caliper bleed valve.

Next air bleed the system (see below).

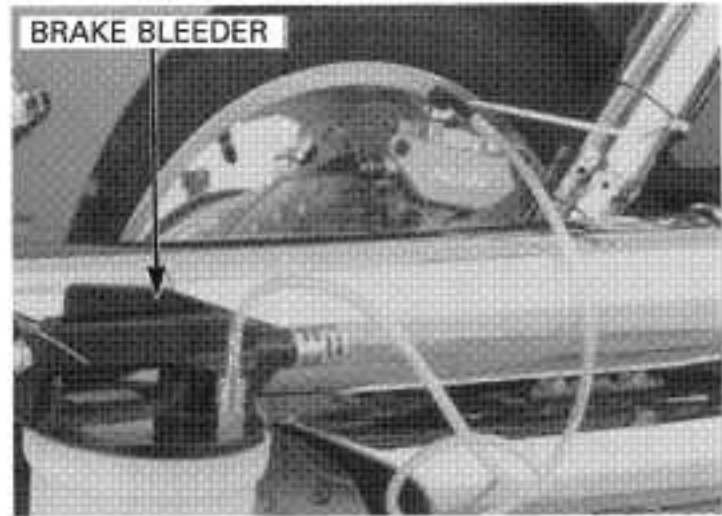

If a brake bleeder is not available, perform the following procedure.

*Do not release the brake pedal until the bleed valve has been closed.*

- (1) Connect a bleed hose to the front caliper lower bleed valve.
  1. Pump the brake pedal several (5 – 10) times quickly, then push the brake pedal all the way down, loosen the front caliper lower bleed valve and loosen the bleed valve 1/4 of a turn. Wait several seconds and close the bleed valve.

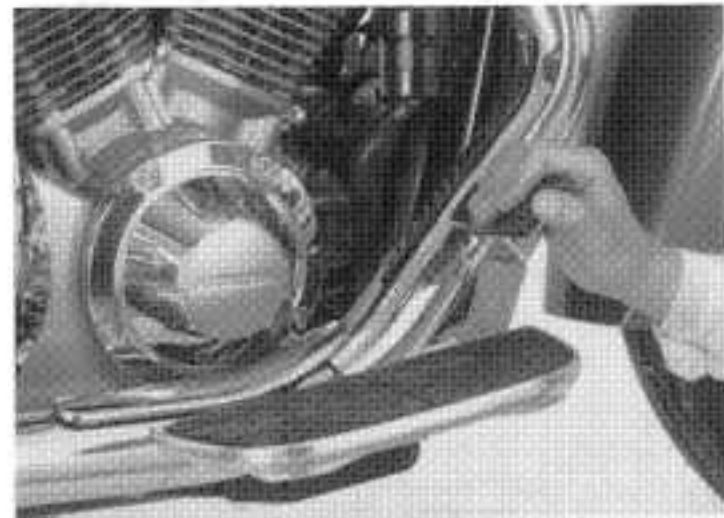

Release the brake pedal slowly and wait several seconds after it reaches the end of its travel.

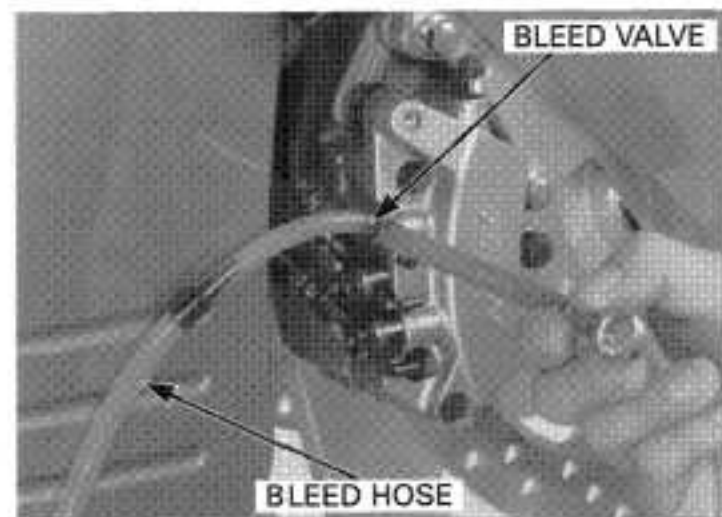

2. Repeat the above procedures until a sufficient amount of the fluid flows out from the caliper lower bleed valve.

It is not a problem if the fluid flowing out from the lower bleed valve contains air bubbles because the lines will be bled later.

- (2) Connect a bleed hose to the rear caliper bleed valve.  
Repeat step 1 and 2 for the rear caliper bleed valve.

Bleed the system of any air (see next page).

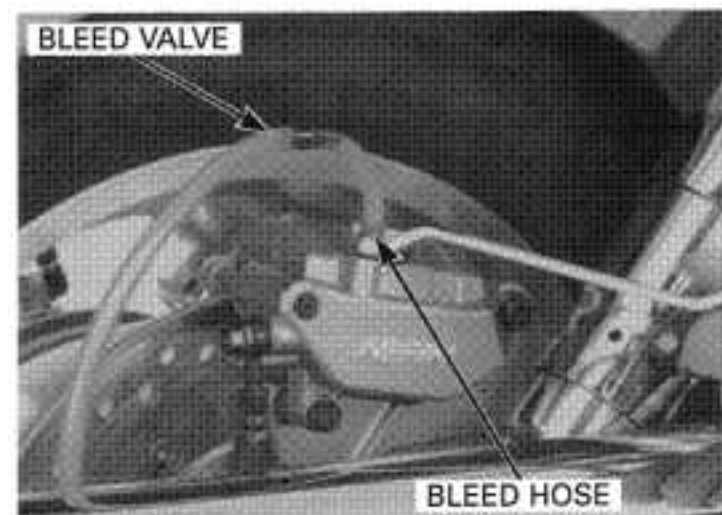

**AIR BLEEDING**

(1) Connect a bleed hose to the rear caliper bleed valve.

1. Pump the brake pedal several (5 – 10) times quickly, then push the brake pedal all the way down, loosen the front caliper lower bleed valve and loosen the bleed valve 1/4 of a turn. Wait several seconds and close the bleed valve.

Release the brake pedal slowly and wait several seconds after it reaches the end of its travel.

2. Repeat the above procedures until air bubbles do not appear in the transparent hose.

(2) Connect a bleed hose to the front caliper lower bleed valve.

- Repeat steps 1 and 2 for the front caliper upper bleed valve.

Note that you may feel strong resistance on the rear (combined) brake pedal during pumping when bleeding air from the caliper. This symptom is caused by the PCV (Proportional Control Valve) function. Be sure to apply the brake pedal fully.

After there are no more air bubbles in the fluid, repeat the air bleeding procedure about two to three times at each bleed valve.

Make sure the bleed valves are closed and operate the brake lever. If it still feels spongy, bleed the system again.

After bleeding the air completely, tighten the bleed valves to the specified torque.

**TORQUE: 6 N·m (0.6 kgf·m, 4.3 lbf·ft)**

Fill the reservoir to the casting ledge with DOT 4 brake fluid to the upper level.

Install the diaphragm, set plate and reservoir cap.

Install the reservoir cover and tighten the bolt to the specified torque.

**TORQUE: 10 N·m (1.0 kgf·m, 7 lbf·ft)**

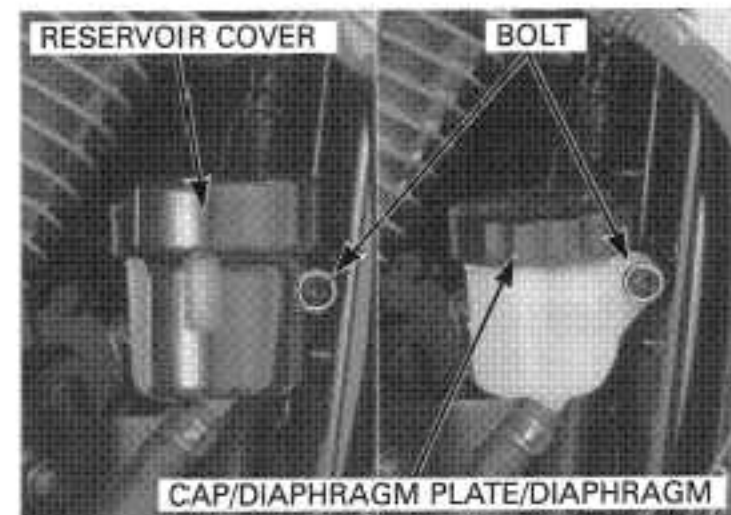
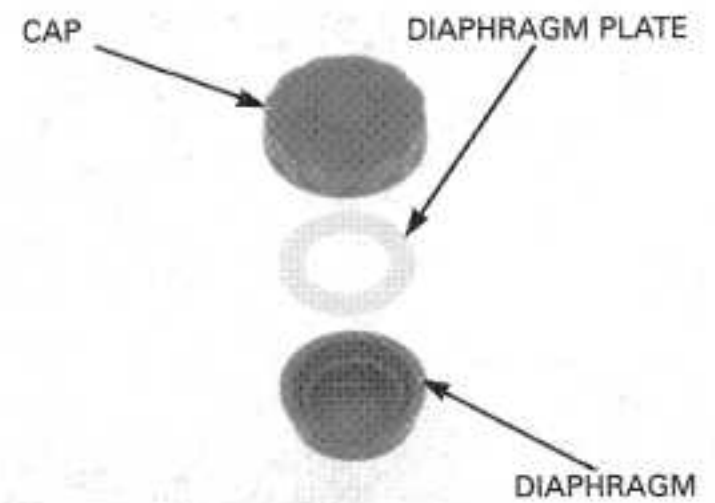
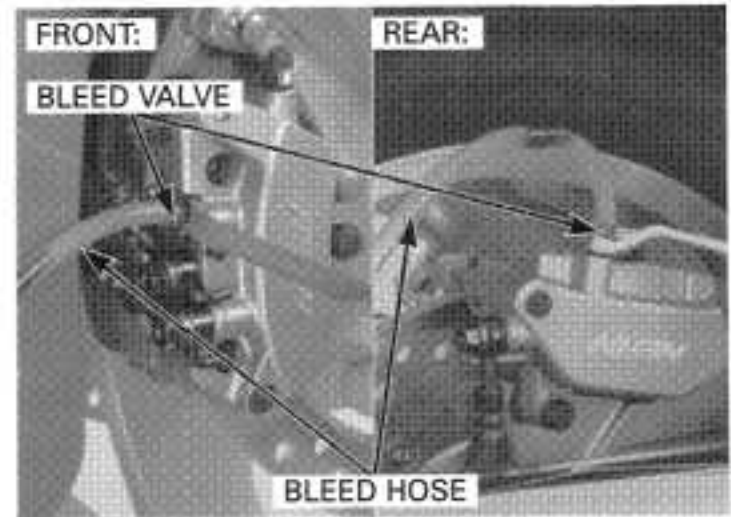
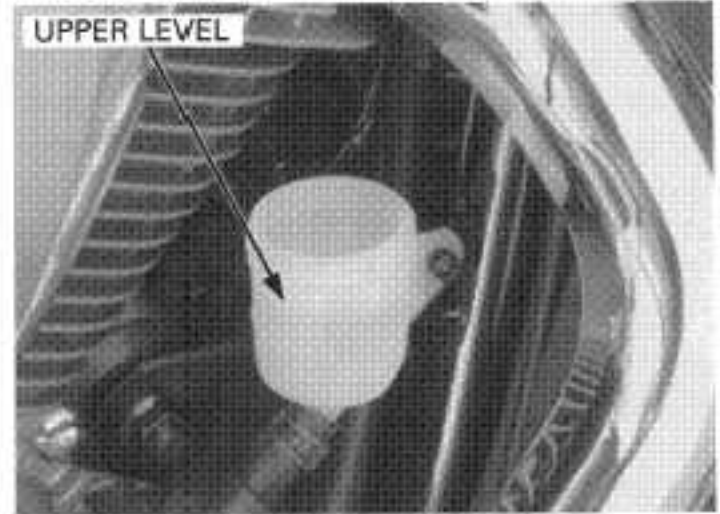



### BRAKE PAD/DISC

#### BRAKE PAD REPLACEMENT

*Always replace the brake pads in pairs to assure even disc pressure.*

##### FRONT

Push the caliper pistons all the way in by pushing the caliper body inward to provide clearance for the new pads.



Remove the pad pin plug and loosen the pad pin.

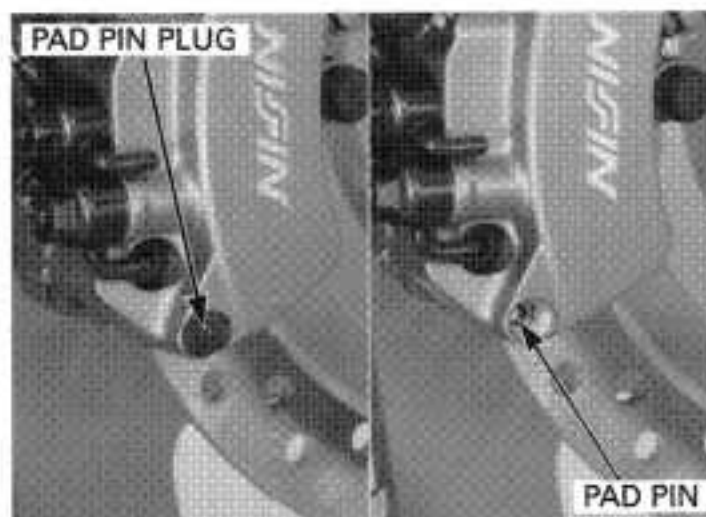

Remove the pad pin and brake pads.

Make sure the pad spring is installed properly. Install new pads so their ends rest on the pad retainers on the bracket properly.

Install the pad pin by pushing the pads against the pad spring to align the pad pin holes in the pads and caliper.

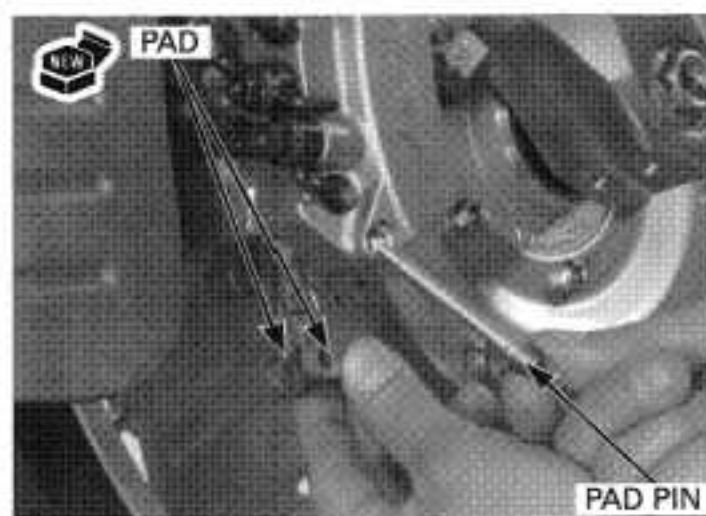

Tighten the pad pin.

**TORQUE: 18 N·m (1.8 kgf·m, 13 lbf·ft)**

Install the pad pin plug securely.

Operate the brake lever and pedal to seat the caliper pistons against the pads.

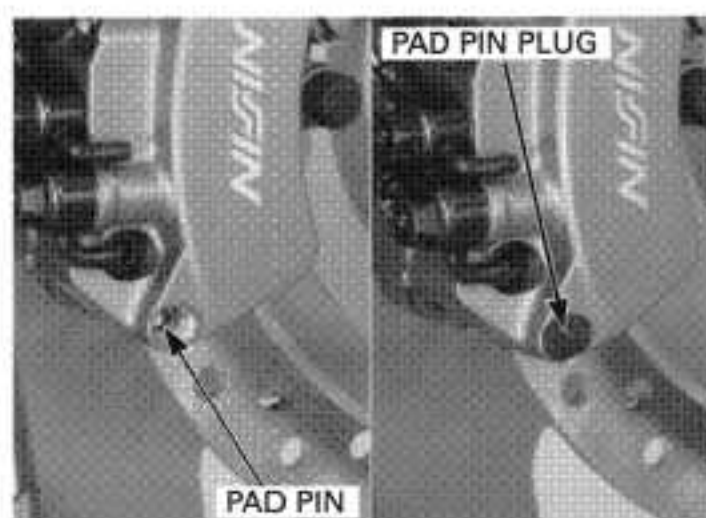

*Always replace the brake pads in pairs to assure even disc pressure.*

**REAR**

Push the caliper pistons all the way in by pushing the caliper body inward to provide clearance for the new pads.

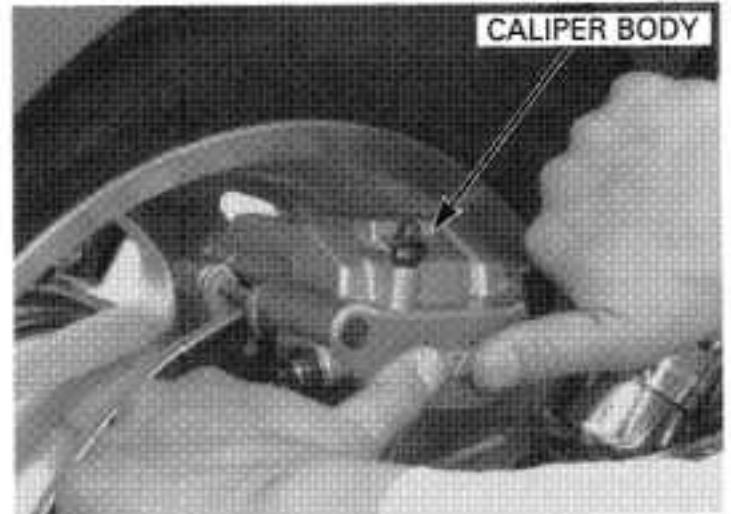

Remove the pad pin plug and loosen the pad pin.

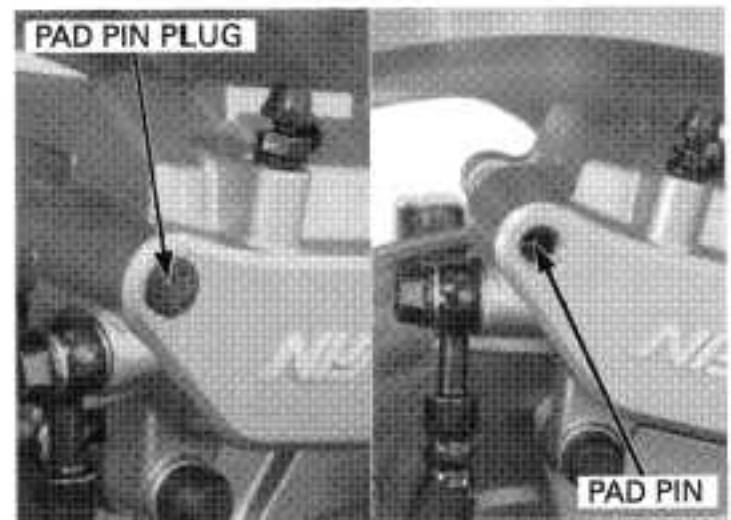

Remove the pad pin and brake pads.

Make sure the pad spring is installed properly. Install new pads so their ends rest on the pad retainer on the bracket properly.

Install the pad pin by pushing the pads against the pad spring to align the pad pin holes in the pads and caliper.

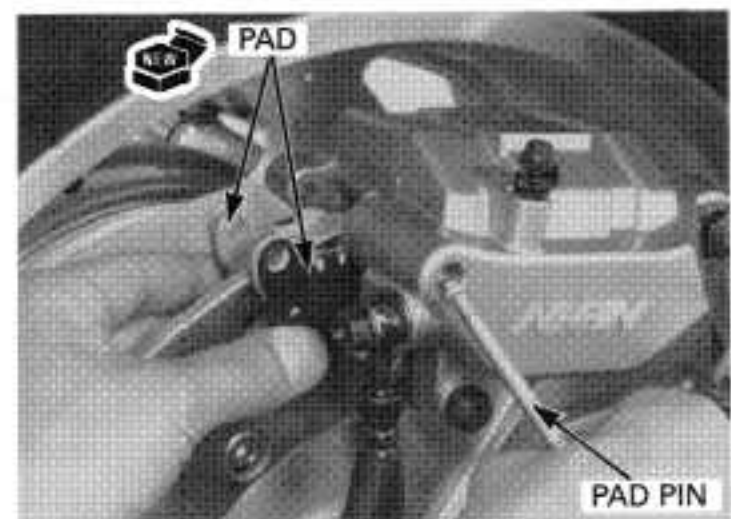

Tighten the pad pin.

**TORQUE: 18 N·m (1.8 kgf·m, 13 lbf·ft)**

Install the pad pin plug securely.

Operate the brake pedal to seat the caliper pistons against the pads.

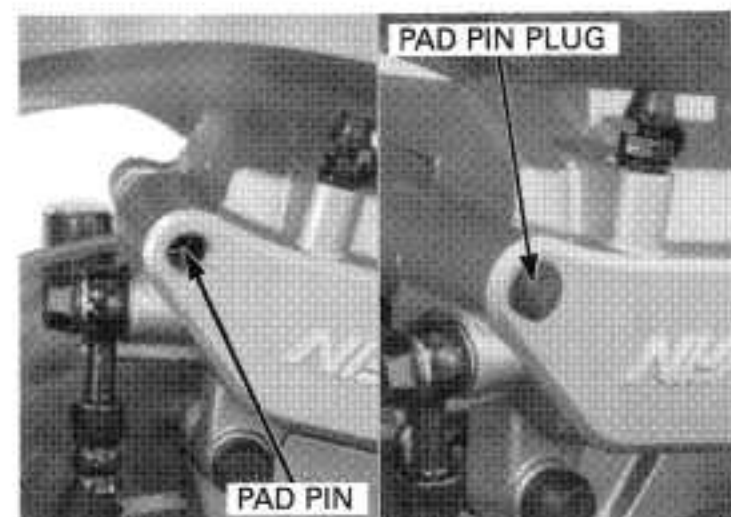



## HYDRAULIC BRAKE

### BRAKE DISC INSPECTION

Visually inspect the disc for damage or cracks.  
Measure the brake disc thickness at several points.

**SERVICE LIMITS:** Front: 3.5 mm (0.14 in)  
Rear: 6.0 mm (0.24 in)

Replace the brake disc if the smallest measurement is less than service limit.



First make sure the wheel bearings are normal, or you will not get accurate results.

Check the brake disc for warpage.

**SERVICE LIMIT:** 0.30 mm (0.012 in)

Replace the brake disc if the warpage exceeds the service limit.

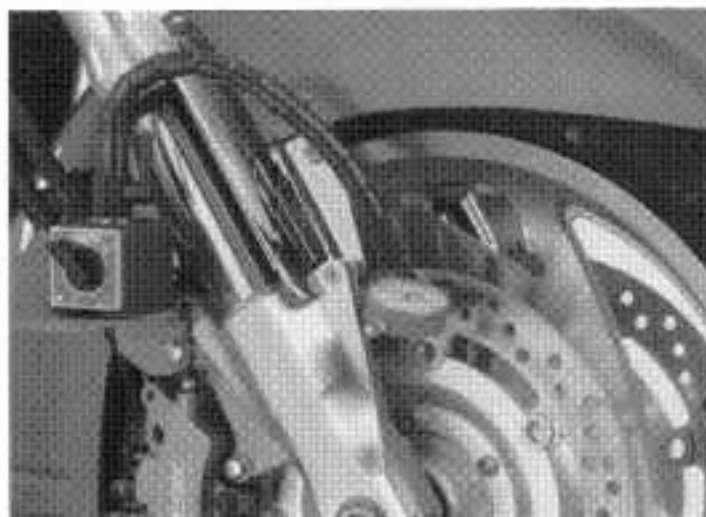

## FRONT MASTER CYLINDER

### REMOVAL

Drain the brake fluid from the hydraulic system (page 15-4).

Remove the rearview mirror.  
Disconnect the front brake light switch connectors.

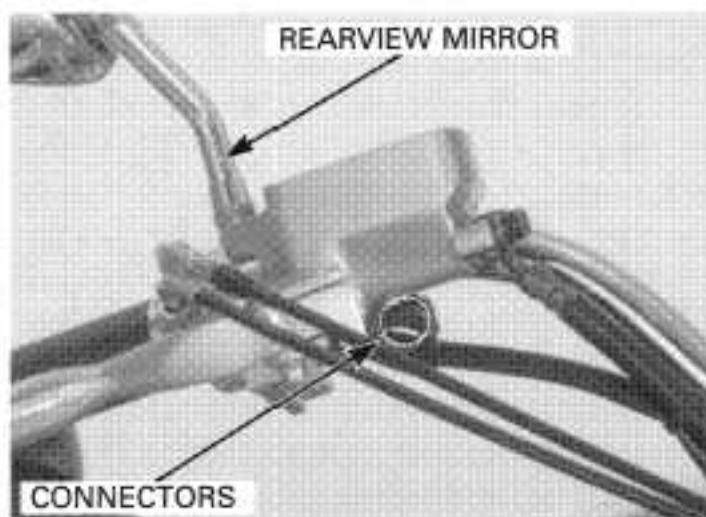

*When removing the oil bolt, cover the end of the hose to prevent contamination.*

Disconnect the brake hose by removing the oil bolt and sealing washers.

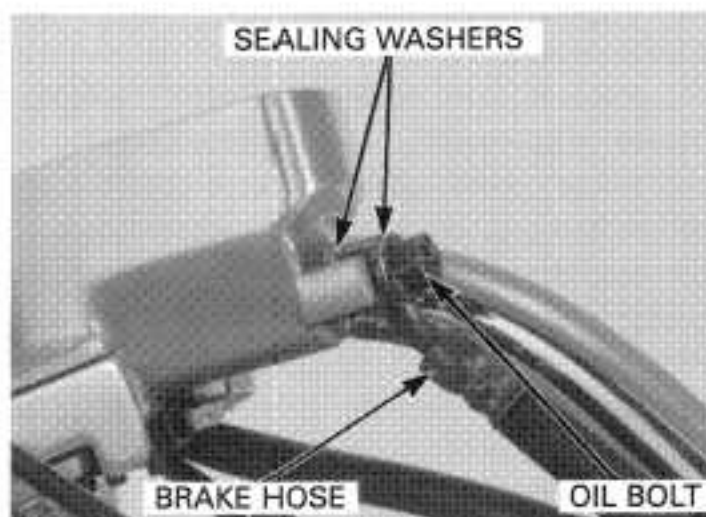

Remove the holder bolts, holder and master cylinder.

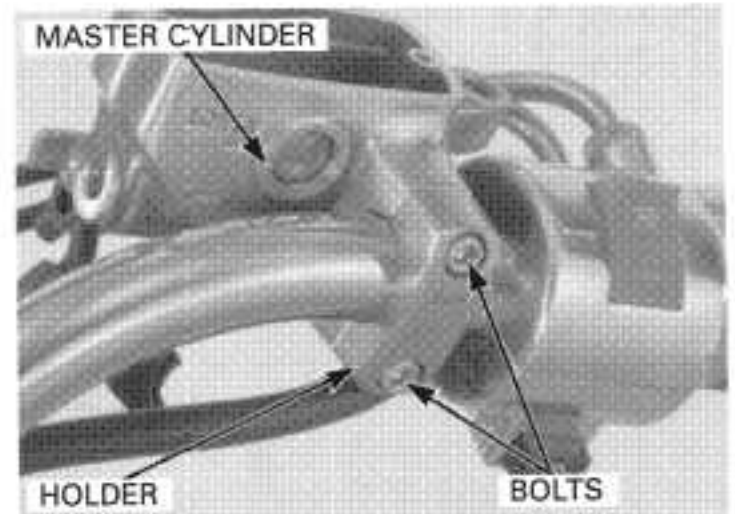

**DISASSEMBLY**

Remove the brake lever pivot nut and bolt.  
Remove the brake lever.

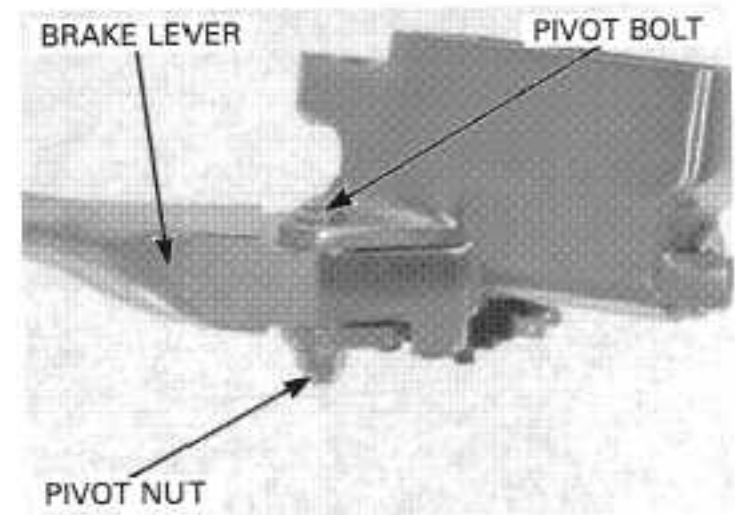

Remove the screw and brake light switch.

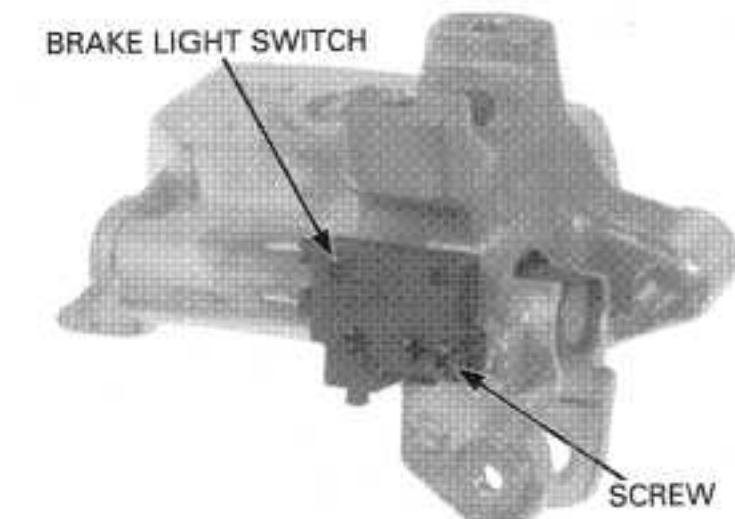

Remove the boot and push rod.

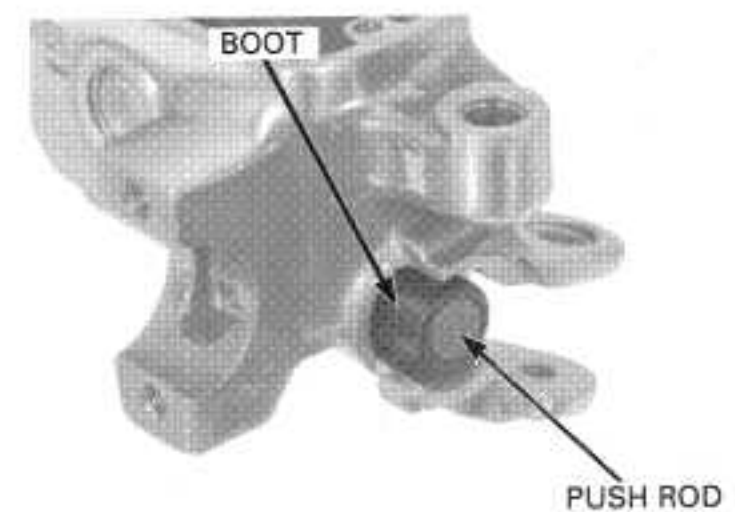

## HYDRAULIC BRAKE

---

Remove the snap ring.

**TOOL:**

**Snap ring pliers**

**07914-SA50001**

Remove the master piston and spring.

Clean the master cylinder, reservoir and master piston in clean brake fluid.

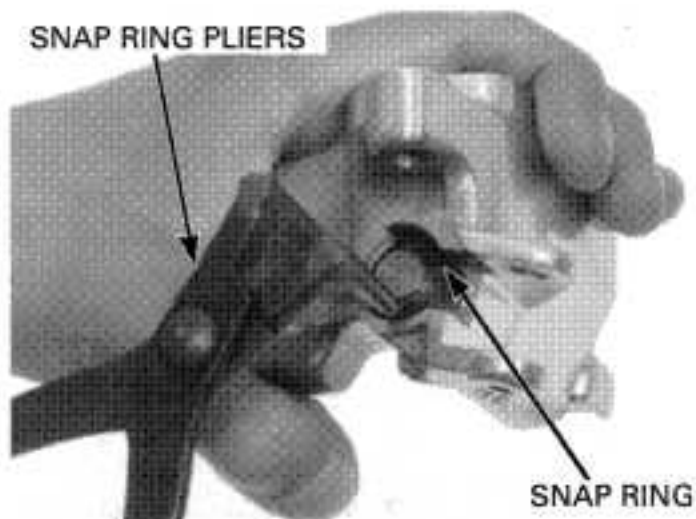

### INSPECTION

Check the piston cups for wear, deterioration or damage.

Check the master cylinder and piston for scoring or damage.

Measure the master cylinder and piston for scoring or damage.

Measure the master cylinder I.D.

**SERVICE LIMIT: 14.055 mm (0.5533 in)**

Measure the master piston O.D.

**SERVICE LIMIT: 13.94 mm (0.549 in)**



ASSEMBLY

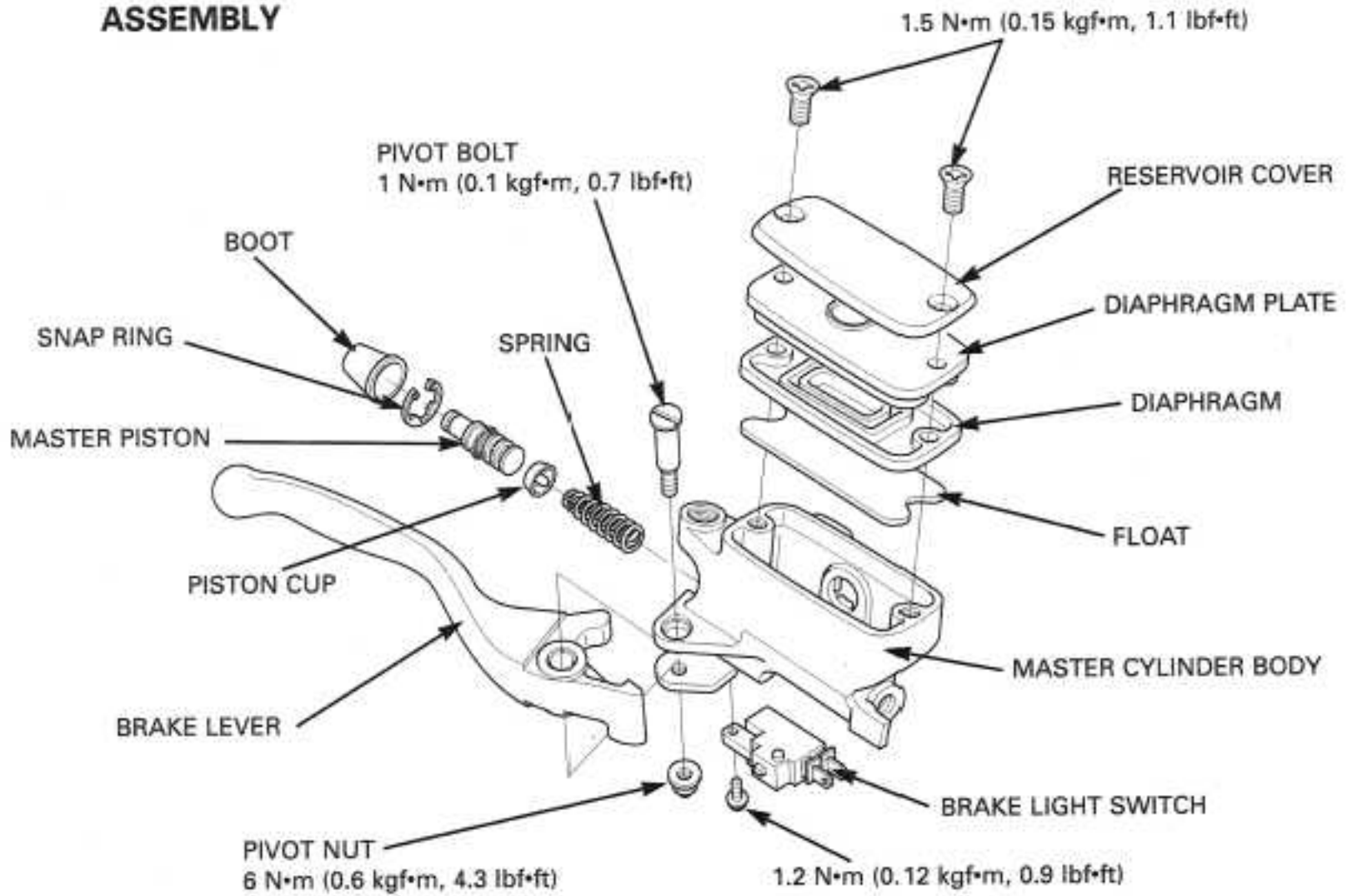

Replace the piston, spring, snap ring and boot as a set; do not substitute individual parts.

Do not allow the piston cup lips to turn inside out.

Coat the master piston and piston cups with clean DOT 4 brake fluid. Install the spring onto the piston cup. Install the piston/spring into the master cylinder.

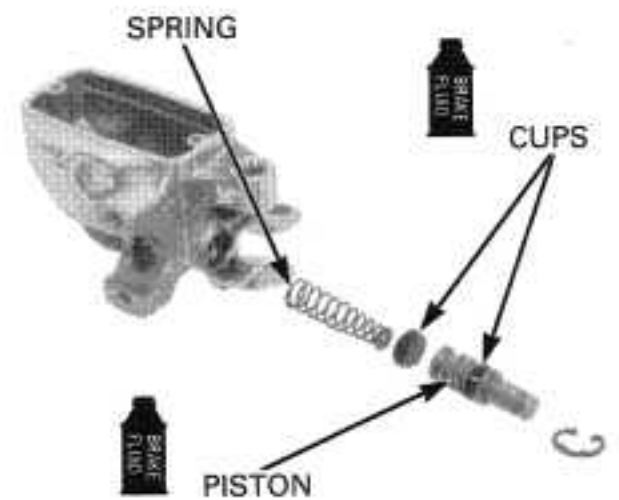

Be certain the snap ring is firmly seated in the groove.

Install the snap ring into the groove in the master cylinder.

**TOOL:**  
Snap ring pliers

07914-SA50001

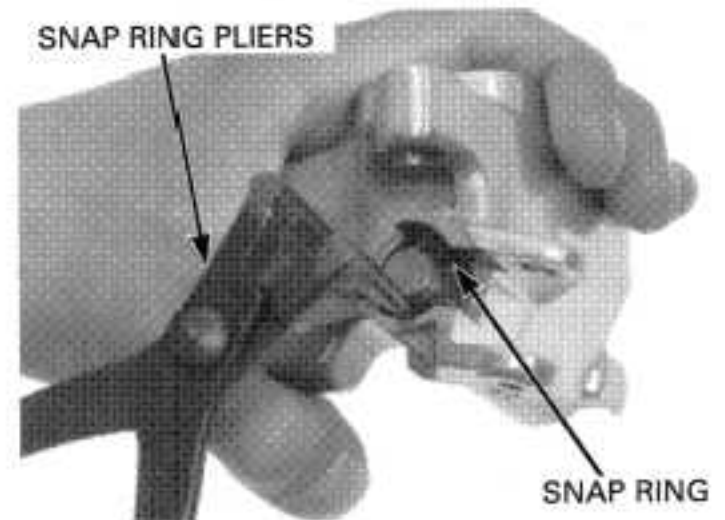

## HYDRAULIC BRAKE

Apply silicone grease to the inside of the boot and master piston tip.  
Install the push rod and boot.

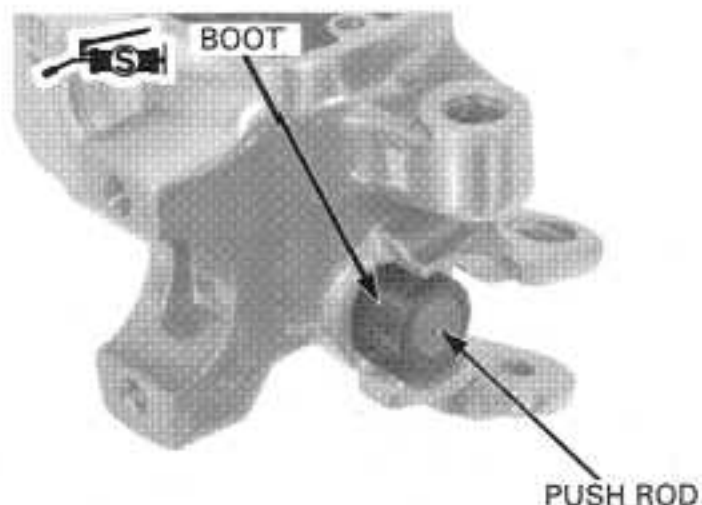

Install the brake light switch and tighten the screw to the specified torque.

**TORQUE: 1.2 N·m (0.12 kgf·m, 0.9 lbf·ft)**

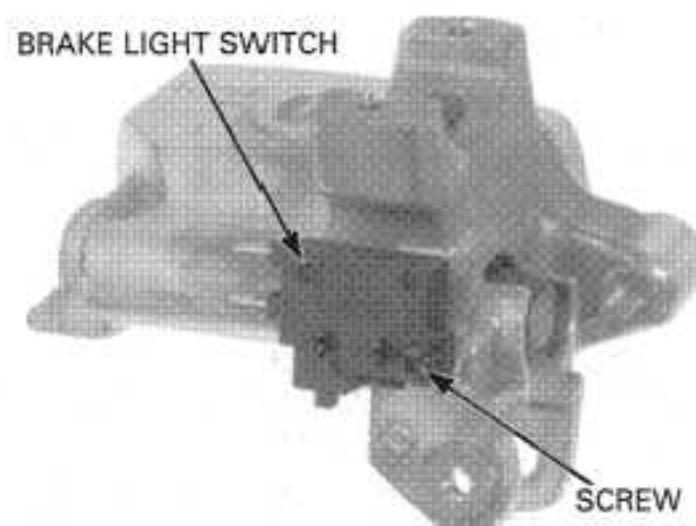

Apply silicone grease to the contact surface of the master piston, then install the brake lever.

Install and tighten the pivot bolt to the specified torque.

**TORQUE: 1 N·m (0.1 kgf·m, 0.7 lbf·ft)**

Install and tighten the pivot nut to the specified torque.

**TORQUE: 6 N·m (0.6 kgf·m, 4.3 lbf·ft)**

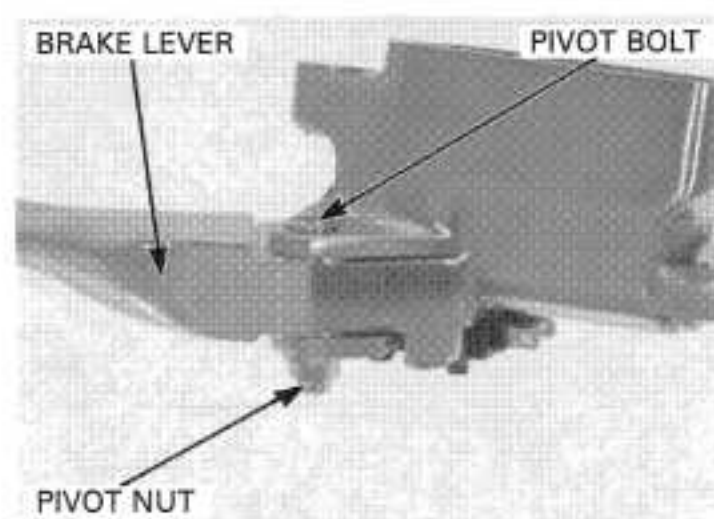

## INSTALLATION

Install the master cylinder and the holder with the "UP" mark facing up.

Align the end of the master cylinder with the punch mark on the handlebar, and tighten the upper bolt first then tighten the lower bolt.

**TORQUE: 12 N·m (1.2 kgf·m, 9 lbf·ft)**

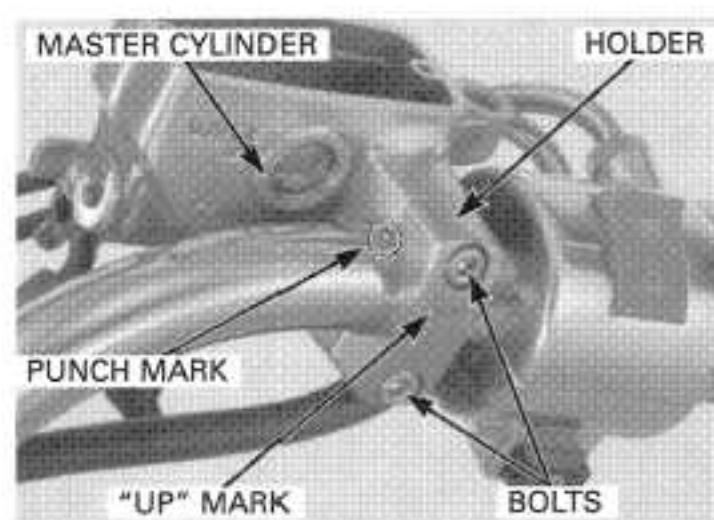



Connect the brake hose to the master cylinder with the oil bolt and new sealing washers. Push the eyelet joint against the stopper, then tighten the oil bolt to the specified torque.

**TORQUE: 34 N·m (3.5 kgf·m, 25 lbf·ft)**

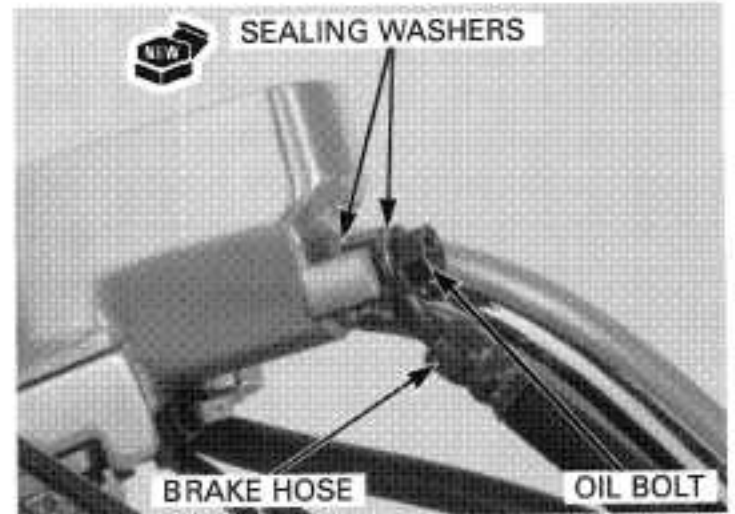

Connect the front brake light switch connectors. Install the right rearview mirror.

Fill and bleed the hydraulic system (page 15-5).

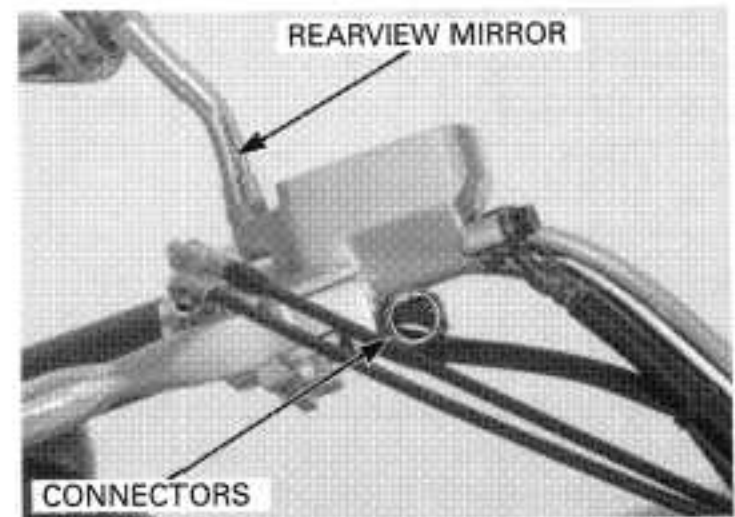

## FRONT CALIPER

### REMOVAL

Drain the brake fluid from the hydraulic system (page 15-4).

Remove the brake pads (page 15-10).

*When removing the oil bolt, cover the end of the hose to prevent contamination.*

Disconnect the brake hoses by removing the oil bolts and sealing washers.

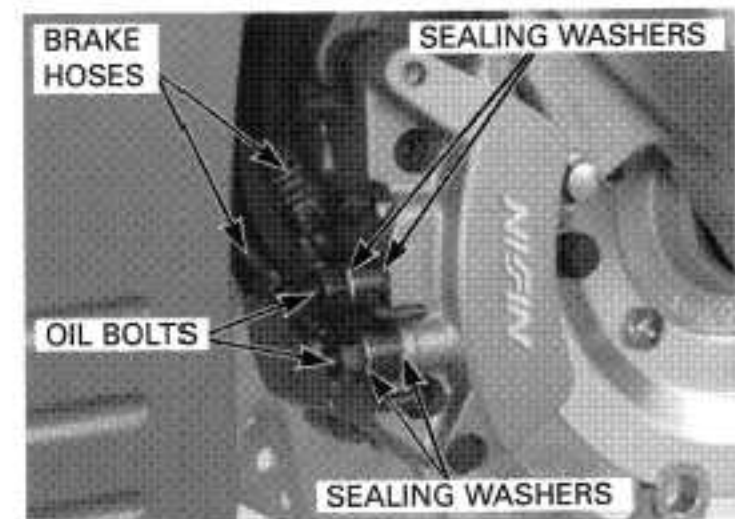

Remove the mounting bolts and front caliper.

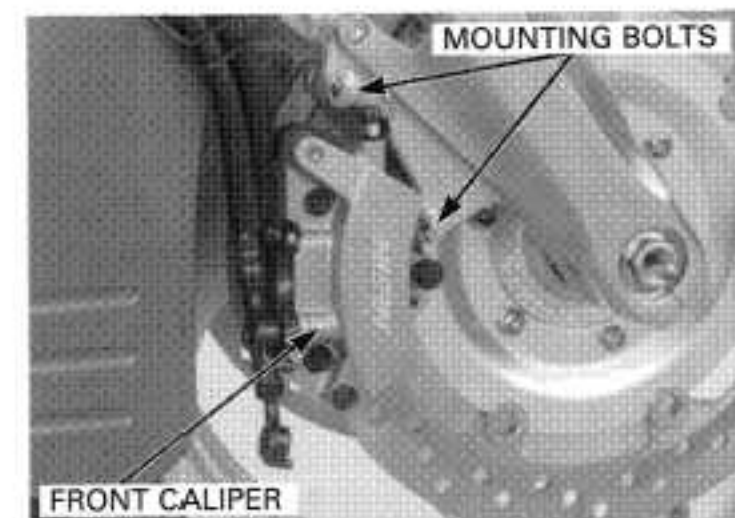

## HYDRAULIC BRAKE

### DISASSEMBLY

Remove the caliper bracket from the caliper body.

Remove the pin boot and retainer from the bracket.

Remove the pin boot and pad spring from the caliper body.

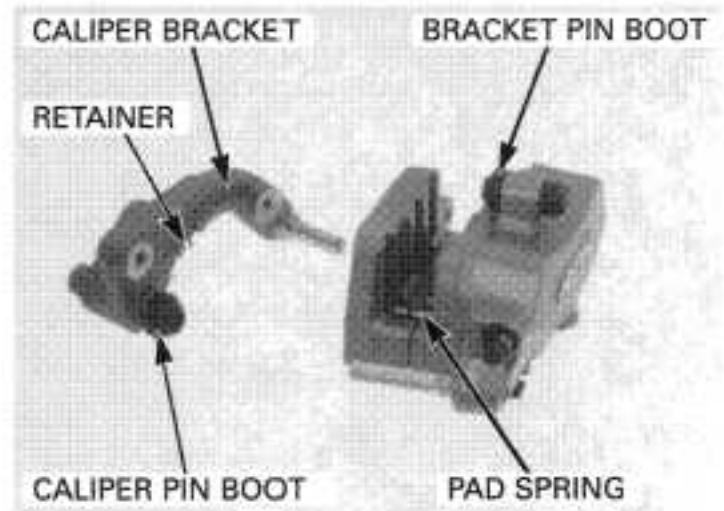

Remove the bolts and caliper body B.

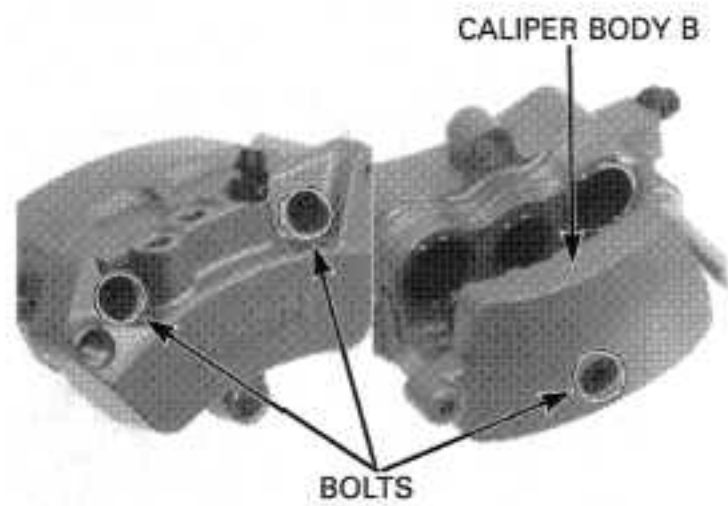

*Do not use high pressure air or bring the nozzle too close to the inlet.*

Place a shop towel over the pistons. Position the caliper body with the piston down and apply small squirts of air pressure to the fluid inlets to remove the pistons.

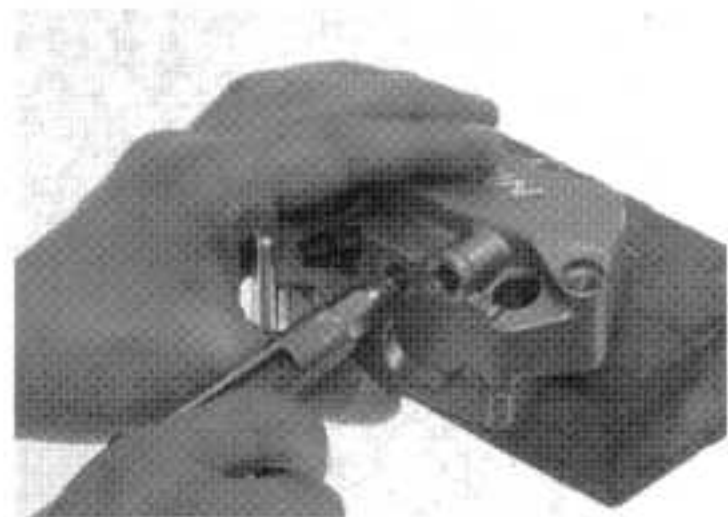

*Be careful not to damage the piston sliding surface.*

Push the dust seals and piston seals in and lift them out.

Clean the seal grooves, caliper pistons and caliper piston sliding surfaces with clean brake fluid.

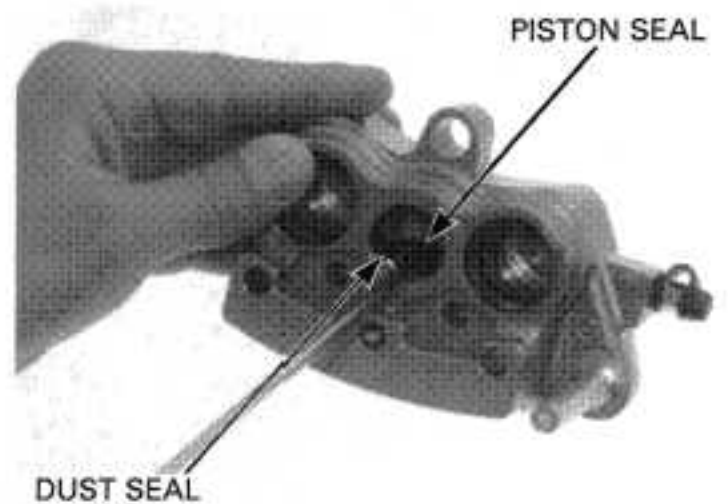

**INSPECTION**

Check the caliper cylinder and pistons for scoring, scratches or damage.

Measure the caliper cylinder I.D.

**SERVICE LIMITS:**

**Right caliper cylinder:** A: 22.710 mm (0.8941 in)  
B: 27.060 mm (1.0654 in)

**Left caliper cylinder:** A: 22.710 mm (0.8941 in)  
B: 25.460 mm (1.0024 in)

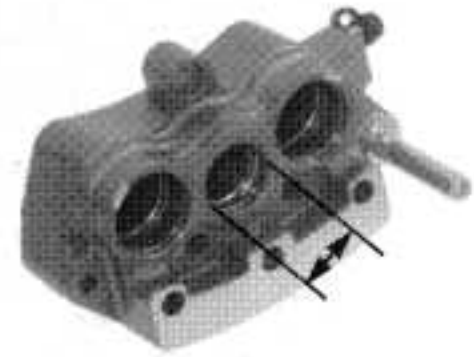

Measure the caliper piston O.D.

**SERVICE LIMITS:**

**Right caliper piston:** A: 22.560 mm (0.8882 in)  
B: 26.910 mm (1.0594 in)

**Left caliper piston:** A: 22.560 mm (0.8882 in)  
B: 25.320 mm (0.9968 in)

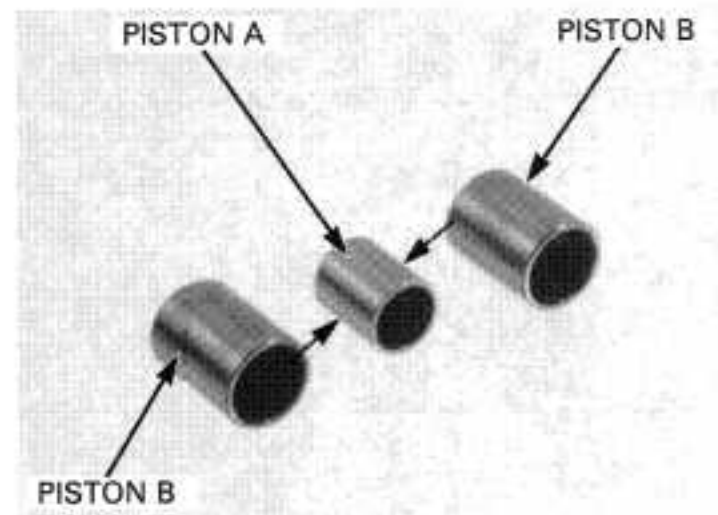

**ASSEMBLY**

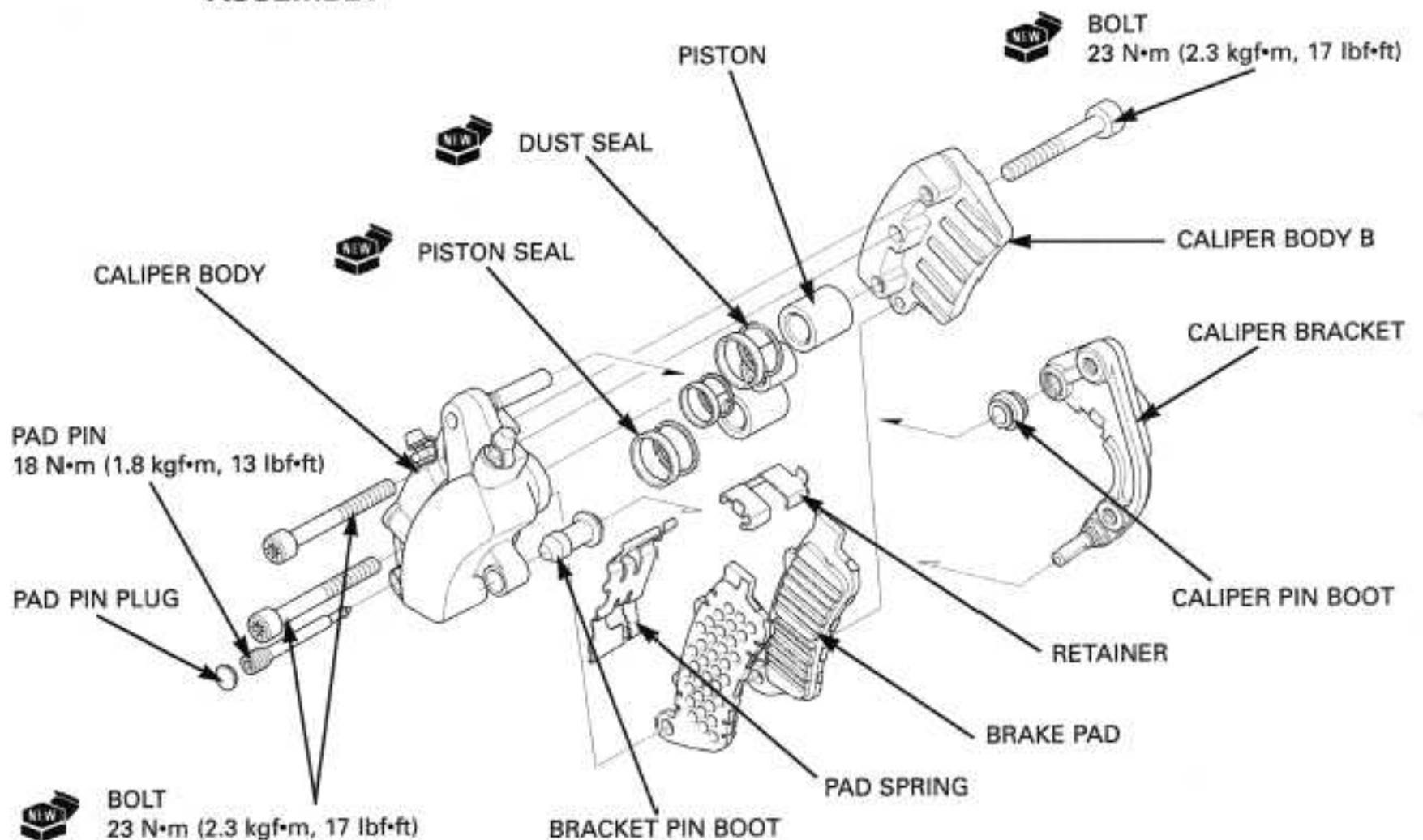

## HYDRAULIC BRAKE

Replace the dust seals and piston seals with new ones.

Replace the caliper and bracket pin boots if they are worn, deteriorated or damaged.

Apply silicone grease to the boot inner surface.

Be sure each part is free from dust or dirt before reassembly.

Coat a new piston seal with clean brake fluid.

Coat a new dust seal with silicone grease.

Install the piston seal and dust seal into the groove of the caliper body.

Coat the caliper piston with clean brake fluid and install them into the caliper cylinder with their closed ends facing the caliper.

Install the caliper body B.

Install and tighten new front caliper body B bolts to the specified torque.

**TORQUE: 23 N·m (2.3 kgf·m, 17 lbf·ft)**

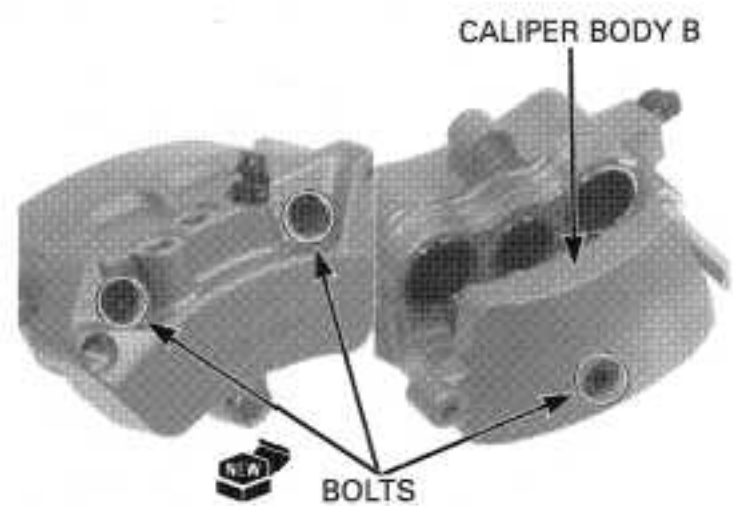
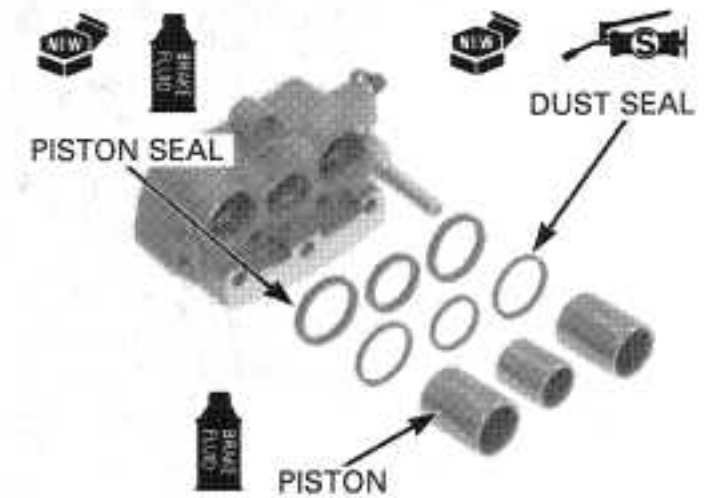

Install the pad spring into the caliper body as shown.

Apply silicone grease to the inside of the boot.  
Install the boot to the caliper.

Apply silicone grease to the inside of the boot.  
Install the boot to the caliper bracket.

Install the retainer to the caliper bracket.

Install the caliper bracket to the caliper.

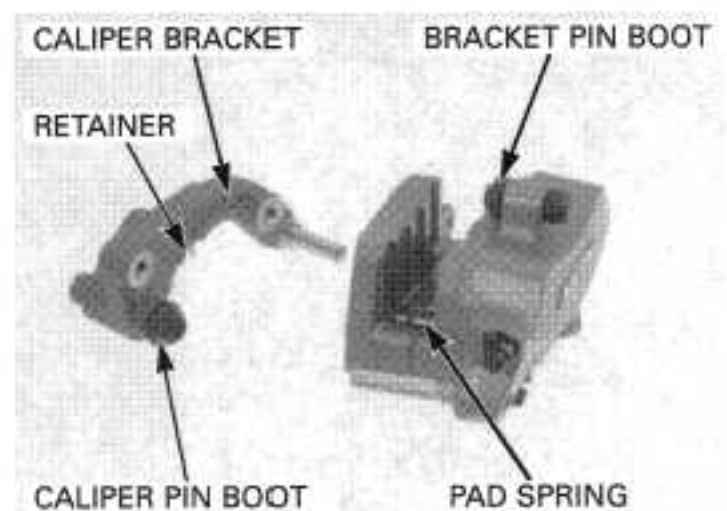

## INSTALLATION

Install the front caliper onto the fork leg.

Install and tighten new front caliper mounting bolts to the specified torque.

**TORQUE: 30 N·m (3.1 kgf·m, 22 lbf·ft)**

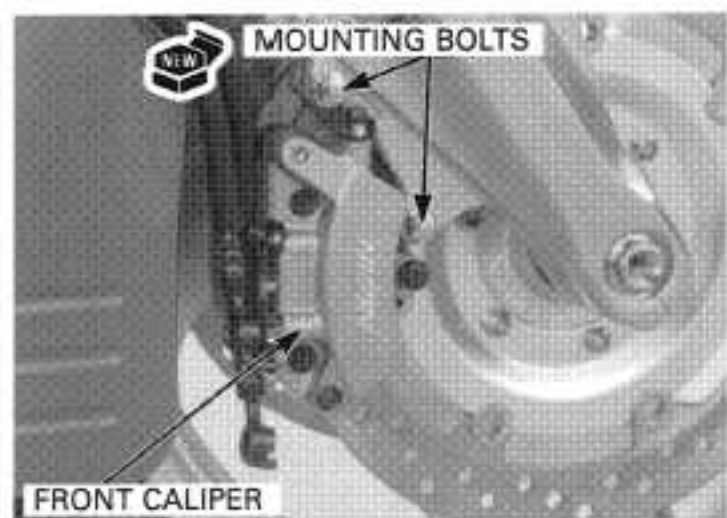



Install the brake hose eyelets to the caliper body with new sealing washers and oil bolts. Push the brake hose eyelet to the stopper on the caliper, then tighten the oil bolts to the specified torque.

**TORQUE: 34 N·m (3.5 kgf·m, 25 lbf·ft)**

Install the brake pads (page 15-10).  
Fill and bleed the hydraulic system (page 15-5).

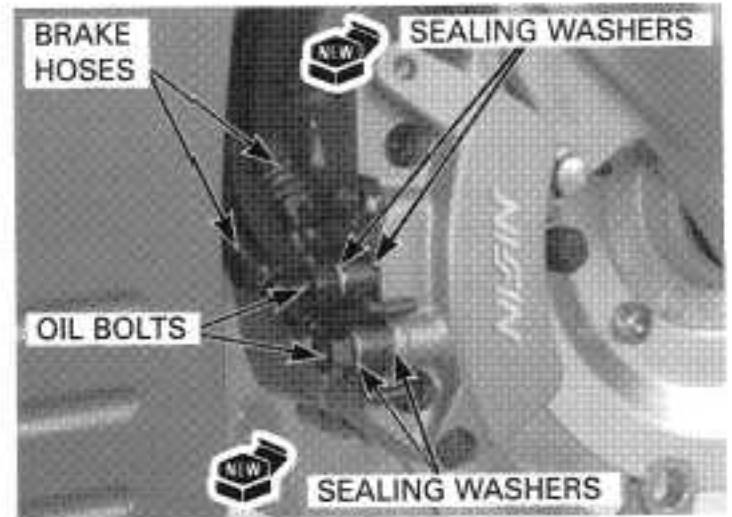

## REAR MASTER CYLINDER/BRAKE PEDAL

### REMOVAL

Drain the brake fluid from the hydraulic system (page 15-4).

Remove the bolt and rear master cylinder reservoir cover.

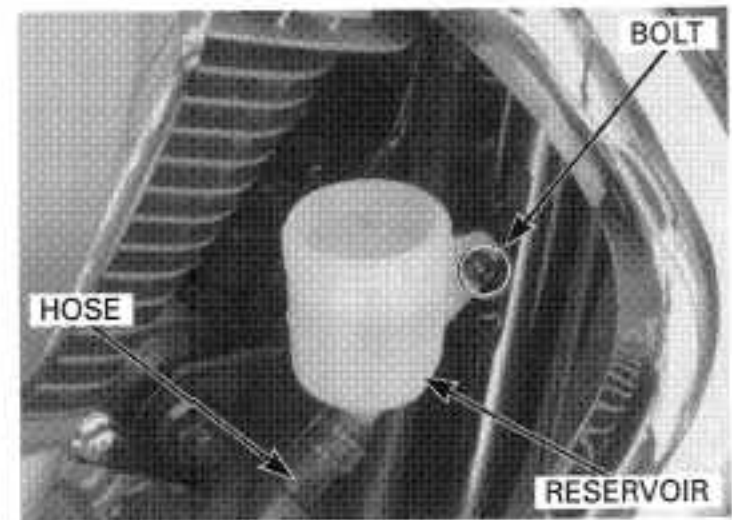

Loosen the oil bolt.

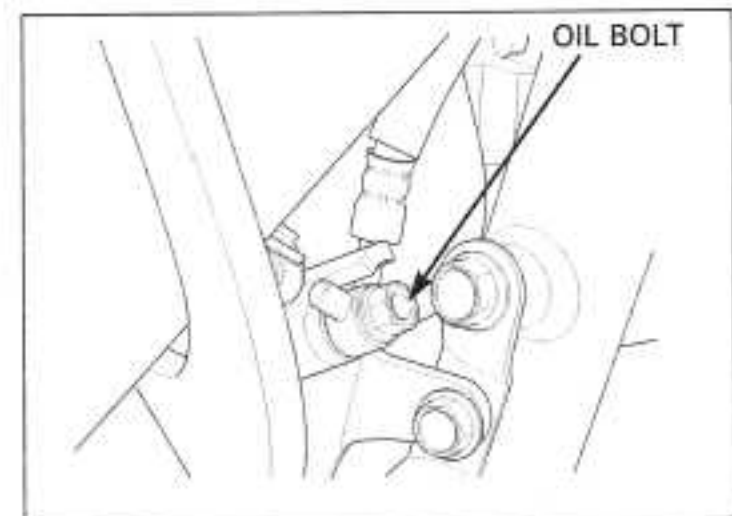

Remove the right step holder bolts, nut and the right step holder.

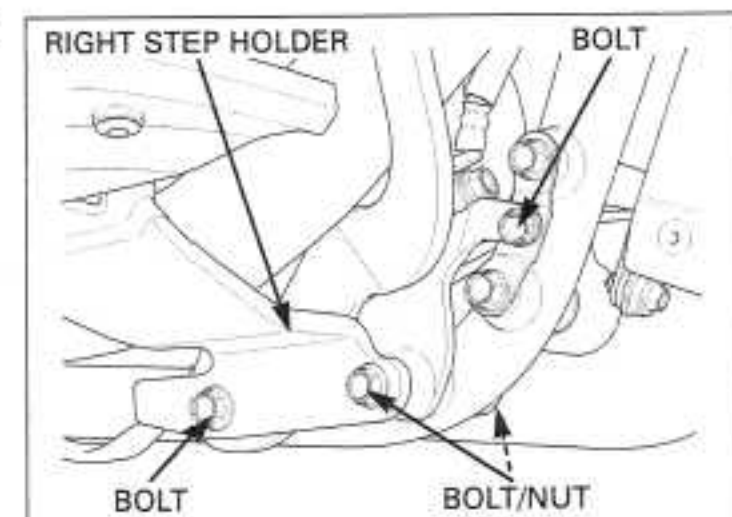



## HYDRAULIC BRAKE

*When removing the oil bolt, cover the end of the hose to prevent contamination.*

Disconnect the brake hose by removing the oil bolt and sealing washers.

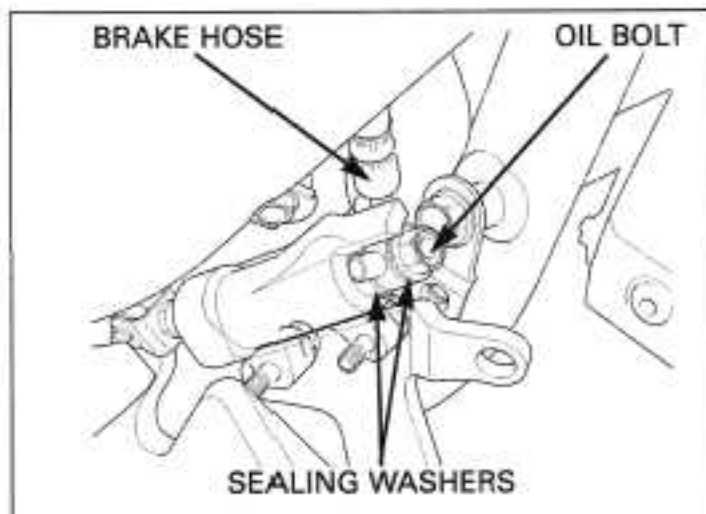

Remove the rear brake light switch spring and brake pedal return spring.

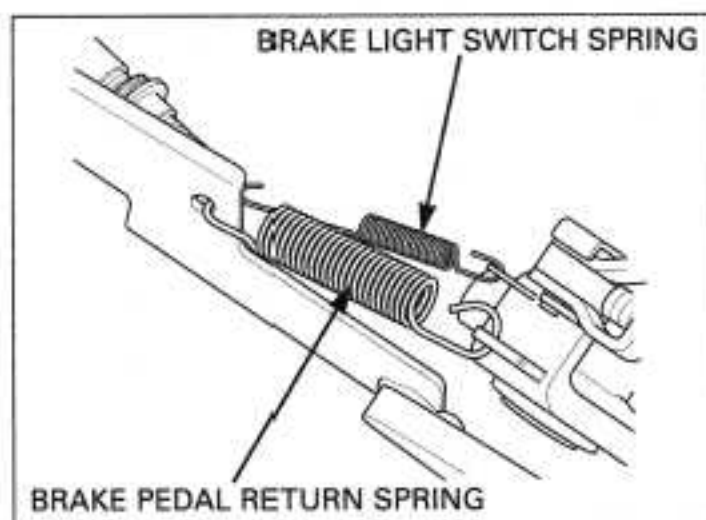

Remove the brake pedal joint cotter pin. Remove the joint pin and brake pedal.

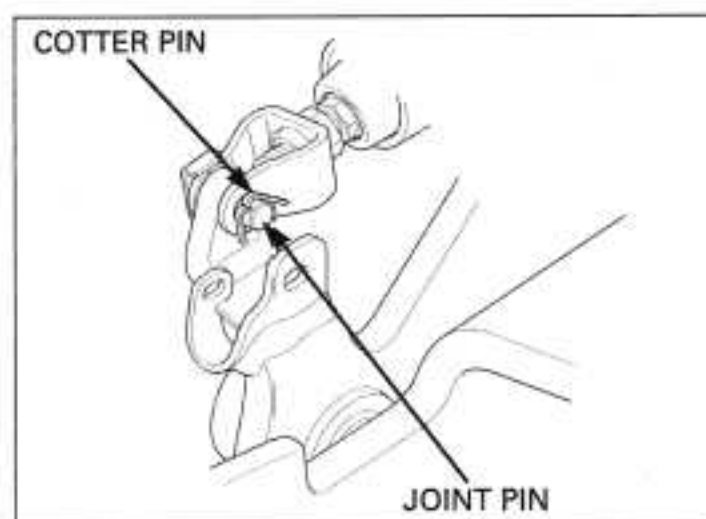

Remove the bolts and rear master cylinder assembly.

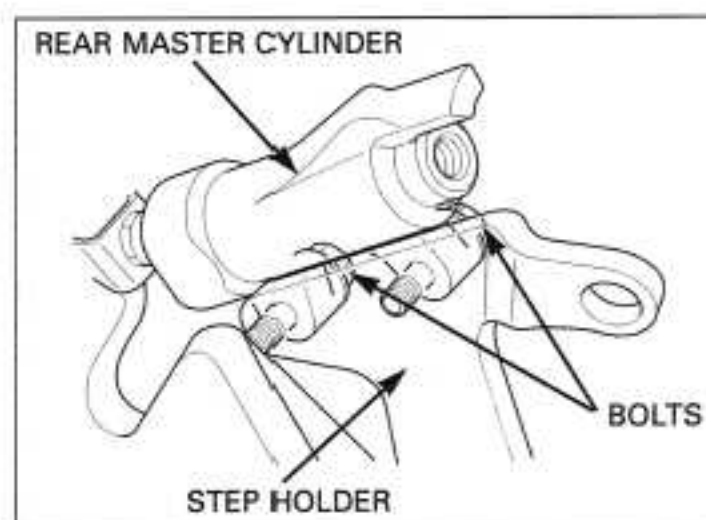

**DISASSEMBLY**

Remove the screw and reservoir hose joint from the master cylinder.  
Remove the O-ring from the reservoir hose joint.

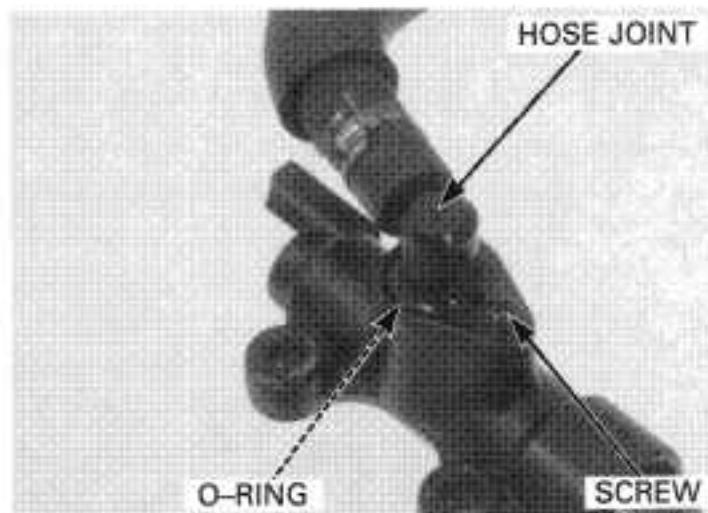

Slide the piston boot from the groove of the rear master cylinder body.

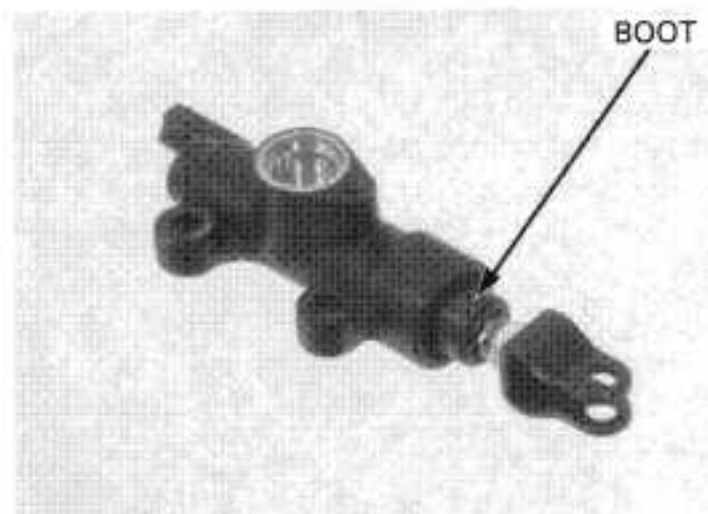

Remove the snap ring from the master cylinder body using the special tool as shown.

**TOOL:**  
**Snap ring pliers** 07914-SA50001

Remove the pushrod/master piston, primary piston cup and spring.

Clean the inside of the cylinder with brake fluid.

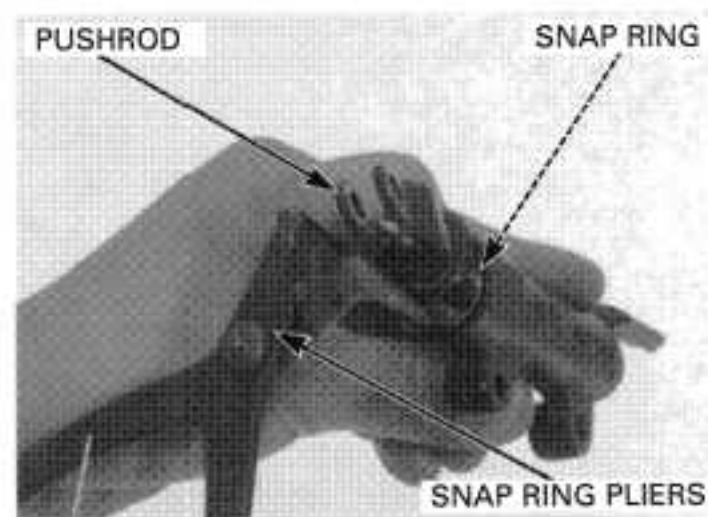
**INSPECTION**

Check the piston boot, primary cup and secondary cup for fatigue or damage.  
Check the master cylinder and piston for abnormal scratches.

Measure the master cylinder I.D.

**SERVICE LIMIT:** 17.515 mm (0.6896 in)

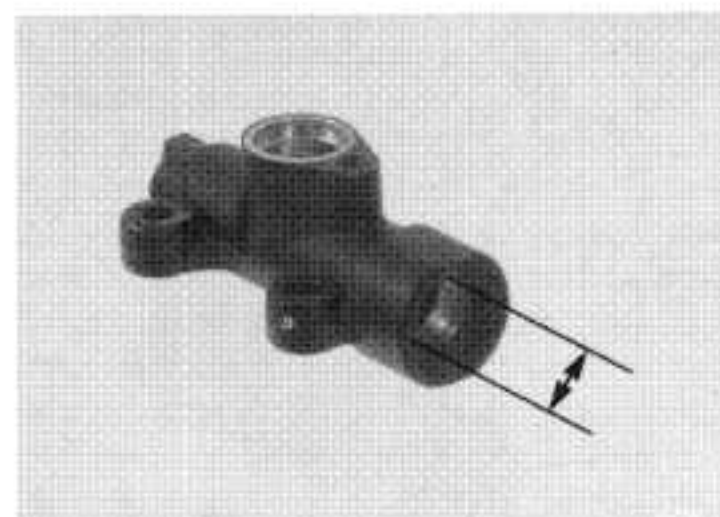

# HYDRAULIC BRAKE

Measure the master cylinder piston O.D.

**SERVICE LIMIT: 17.405 mm (0.6852 in)**

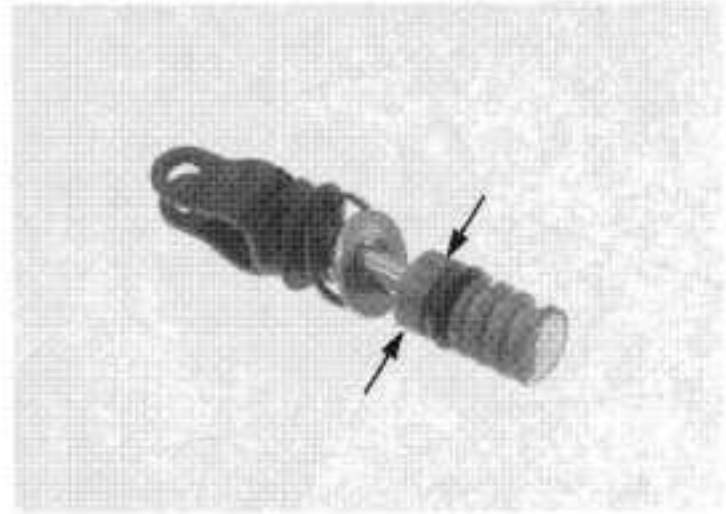

## ASSEMBLY

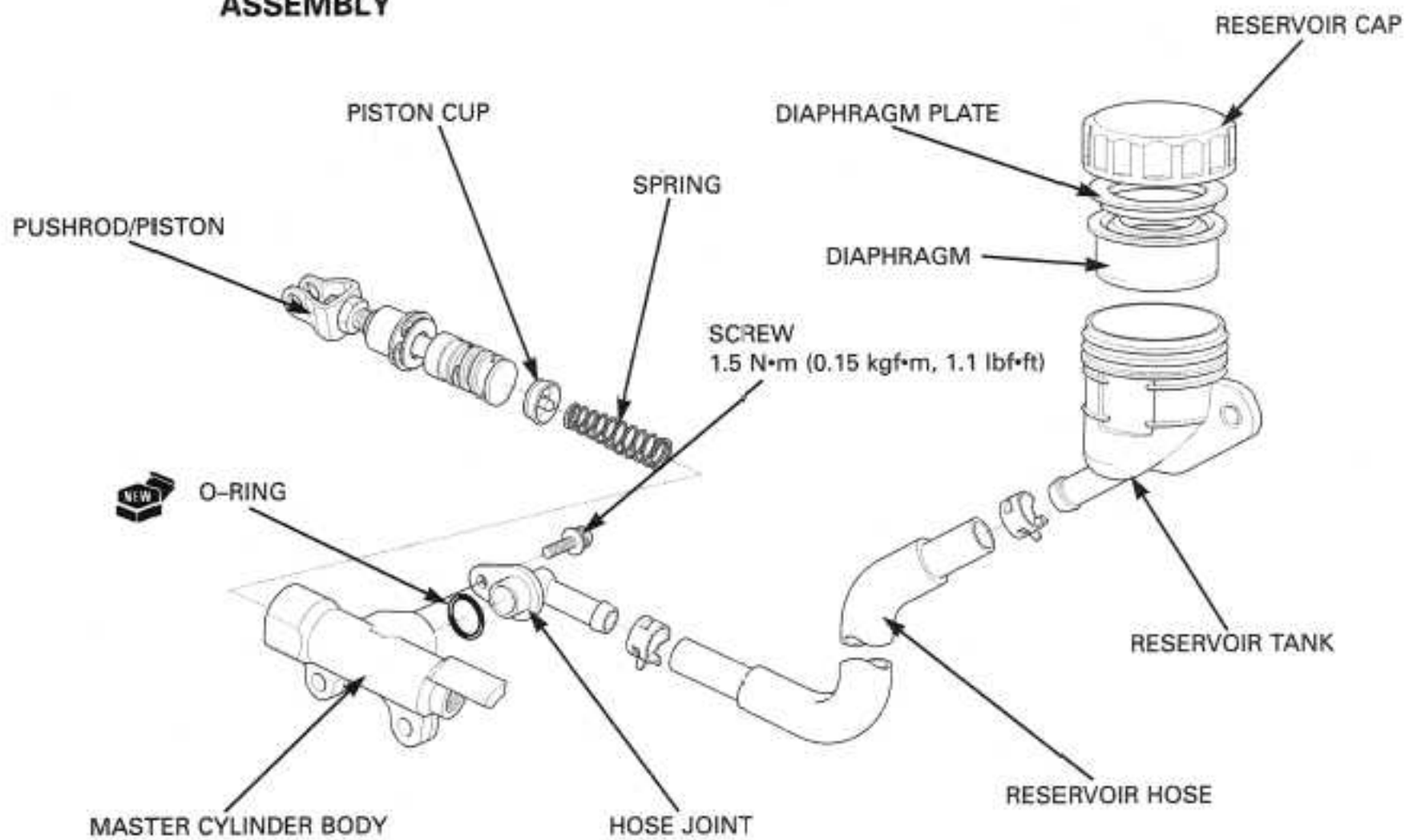

Replace the piston, spring, snap ring and boot as a set; do not substitute individual parts.

Do not allow the piston cup lips to turn inside out.

Coat the master piston and piston cups with clean DOT 4 brake fluid. Install the spring onto the primary piston cup. Install the spring/primary piston cup into the master cylinder.

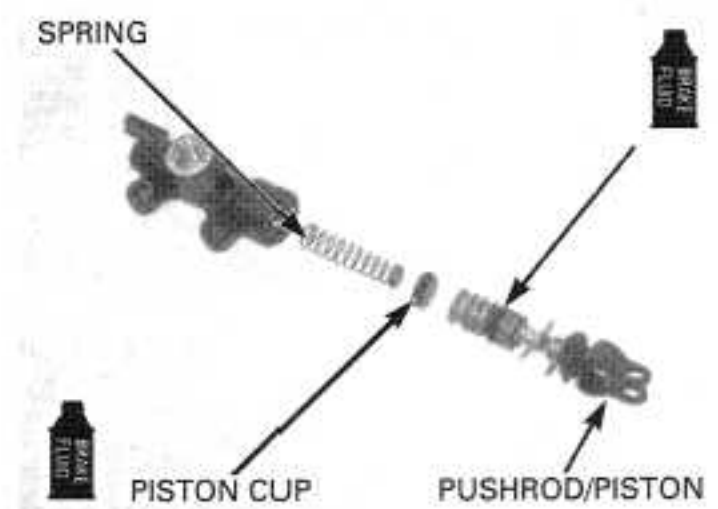

*Be certain the snap ring is firmly seated in the groove.*

Install the pushrod/piston into the master cylinder. Install the snap ring using the special tool.

**TOOL:**  
Snap ring pliers 07914-SA50001

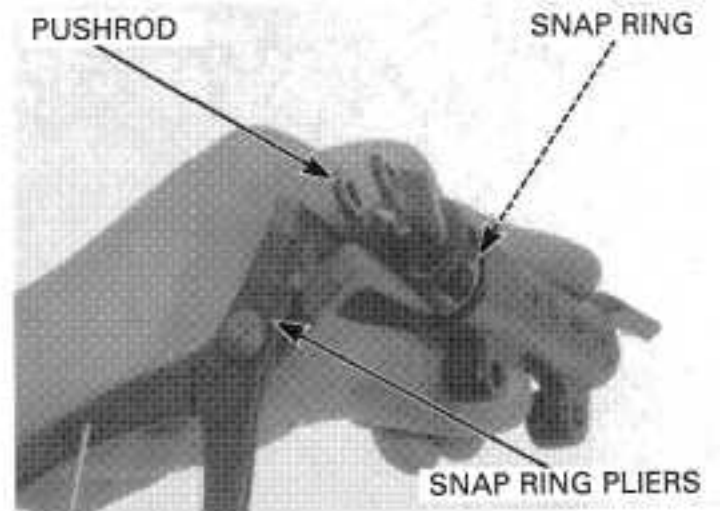

Install the piston boot to the groove on the rear master cylinder body.

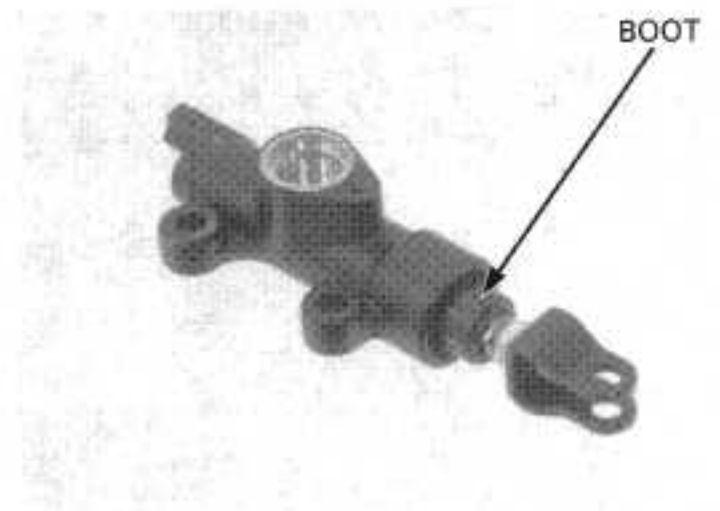

If the pushrod is reinstalled, adjust the pushrod length so that the distance from the center of the master cylinder rear mounting bolt hole to the center of the joint pin hole is 65 mm (2.6 in). After adjustment, tighten the lock nut to the specified torque.

**TORQUE: 18 N·m (1.8 kgf·m, 13 lbf·ft)**

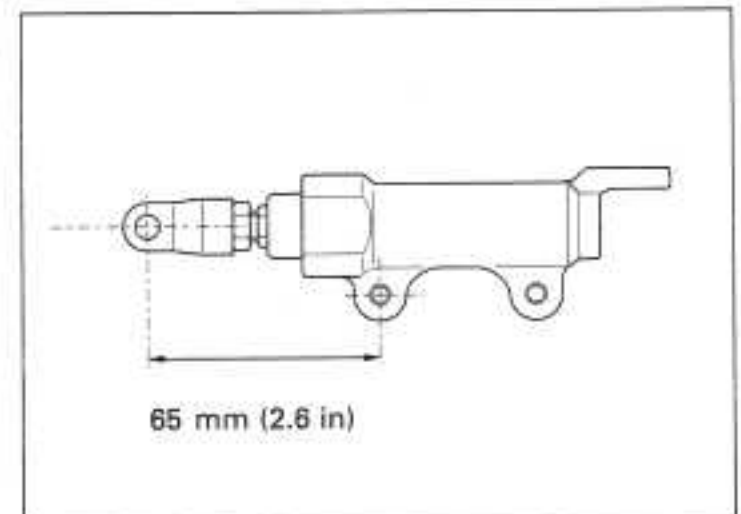

Apply brake fluid to a new O-ring and install it onto the hose joint.

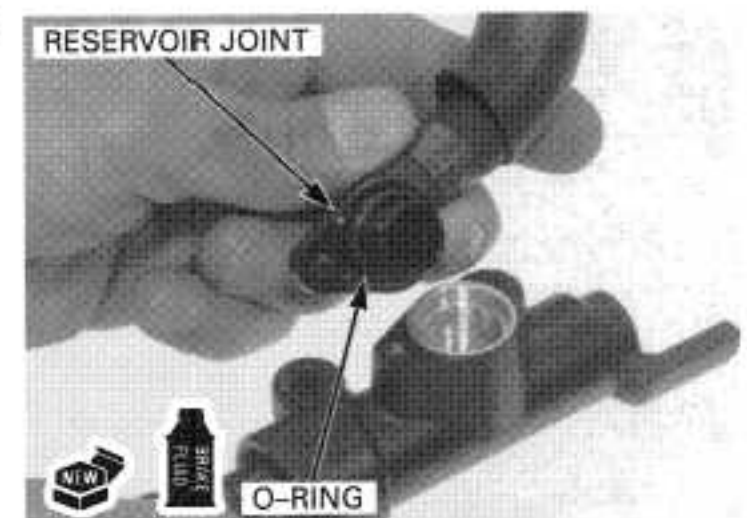

## HYDRAULIC BRAKE

Install the reservoir joint into the master cylinder.  
Install and tighten the screw to the specified torque.

**TORQUE: 1.5 N·m (0.15 kgf·m, 1.1 lbf·ft)**

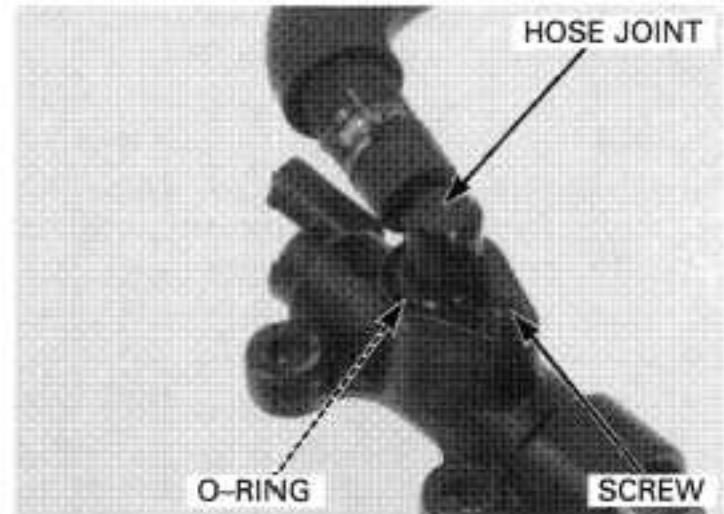

### INSTALLATION

Place the master cylinder onto the right step holder and tighten the mounting bolts to the specified torque.

**TORQUE: 12 N·m (1.2 kgf·m, 9 lbf·ft)**

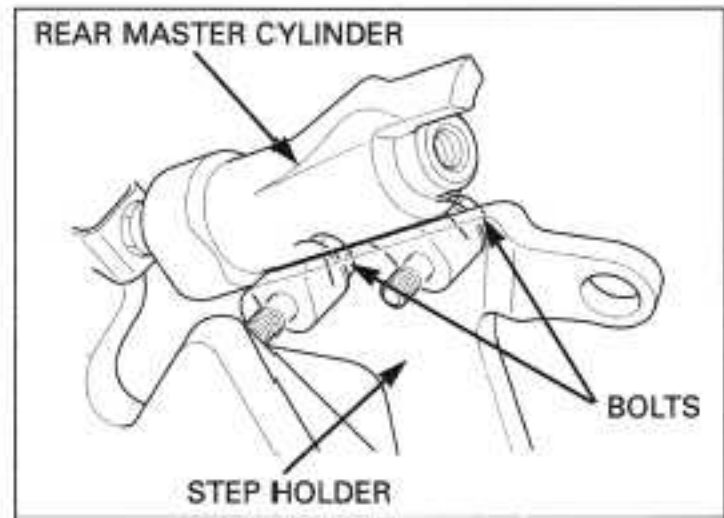

Connect the brake pedal to the pushrod lower joint.  
Install the joint pin and secure it with a new cotter pin.

Install the brake pedal and joint pin.

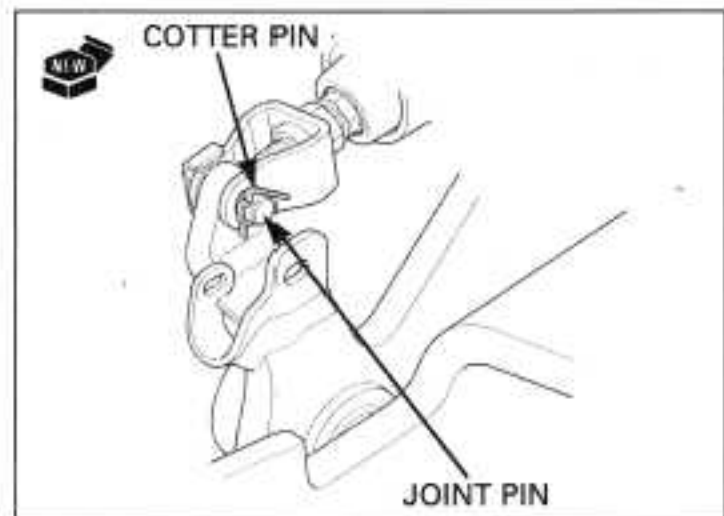

Apply grease to the sliding surface of the brake pedal pivot and new dust seal lips.  
Install the new dust seals onto the pivot of the brake pedal.

Install the brake pedal.  
Hook the brake light switch spring and the brake pedal return spring.

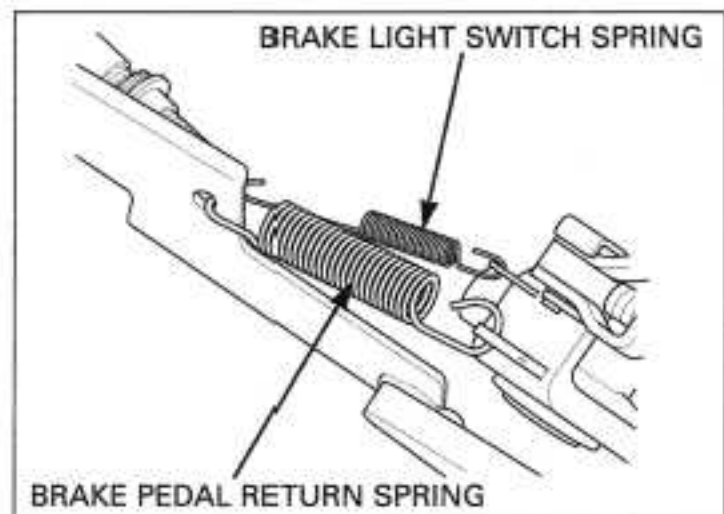



Install the brake hose with the oil bolt and new sealing washers.  
Do not tighten the oil bolt yet.



Install the right step holder and tighten the right step holder bolts to the specified torque.

**TORQUE: 39 N·m (4.0 kgf·m, 29 lbf·ft)**

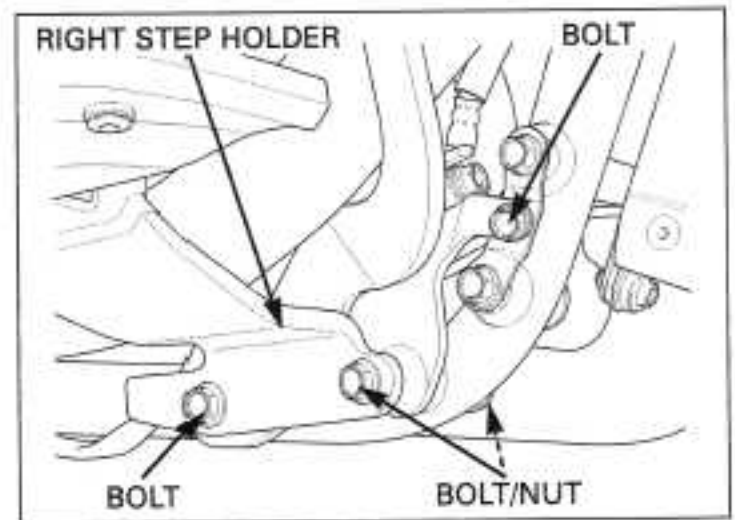

Push the eyelet joint against the stopper, then tighten the oil bolt to the specified torque.

**TORQUE: 34 N·m (3.5 kgf·m, 25 lbf·ft)**

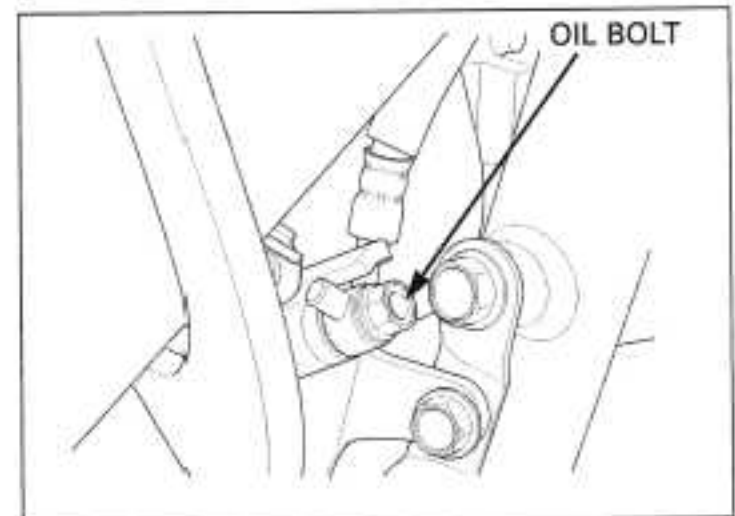

Install the reservoir onto the frame and tighten the mounting bolt.

Fill and bleed the hydraulic system (page 15-7).

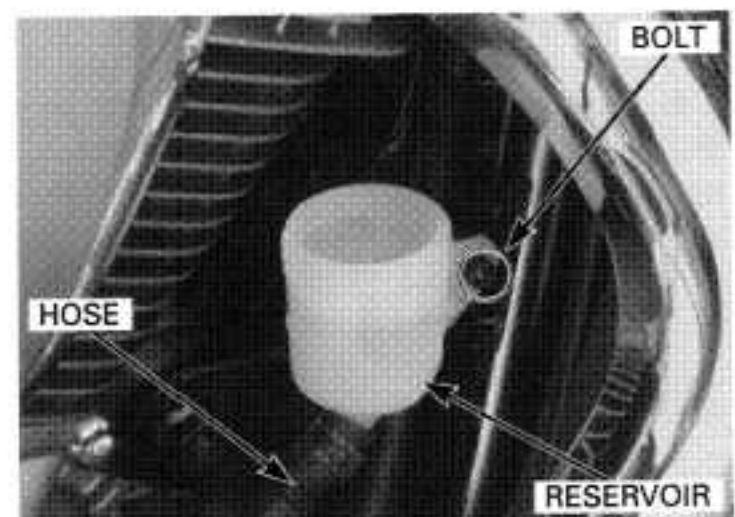

## HYDRAULIC BRAKE

Install the reservoir cover and tighten the mounting bolt to the specified torque.

**TORQUE: 10 N·m (1.0 kgf·m, 7 lbf·ft)**

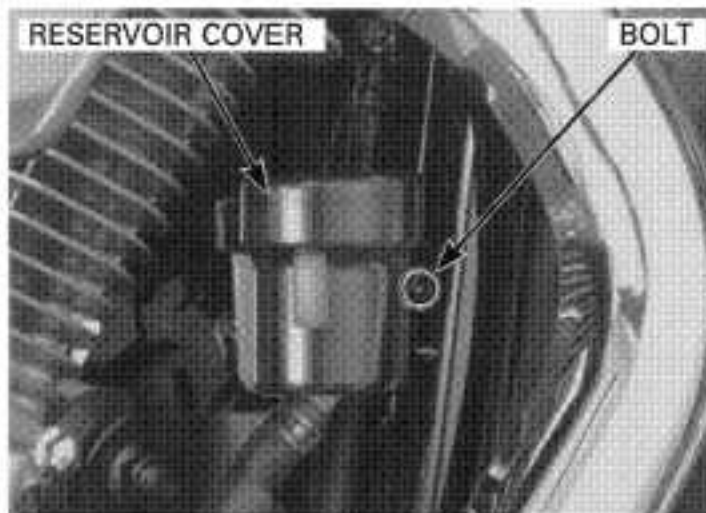

## REAR CALIPER

### REMOVAL

Drain the brake fluid from the hydraulic system (page 15-4).

*When removing the oil bolt, cover the end of the hose to prevent contamination.*

Disconnect the brake hose by removing the oil bolt and sealing washers.

Remove the brake pads (15-11).  
Remove the rear wheel (page 14-3).

Remove the rear caliper.

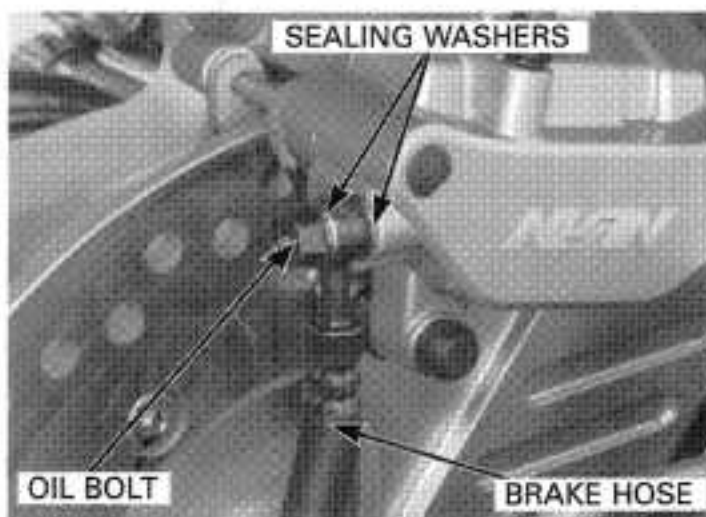

### DISASSEMBLY

Remove the bracket from the caliper body.

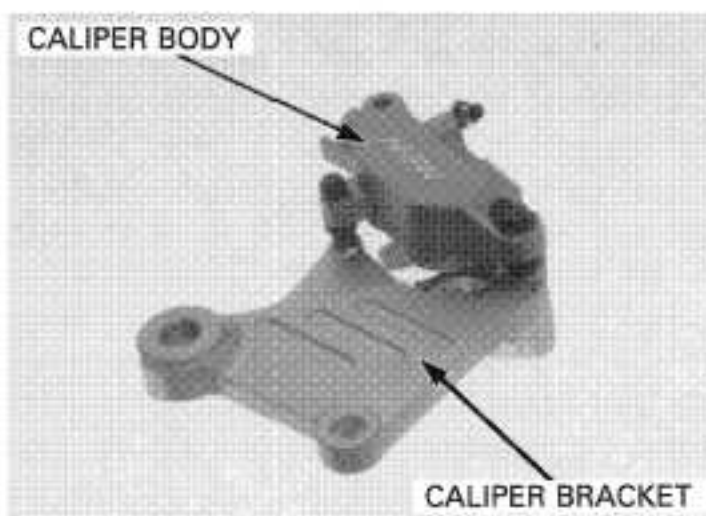

Remove the pin boot and retainer from the bracket.

Remove the pin boot and pad spring from the caliper body.

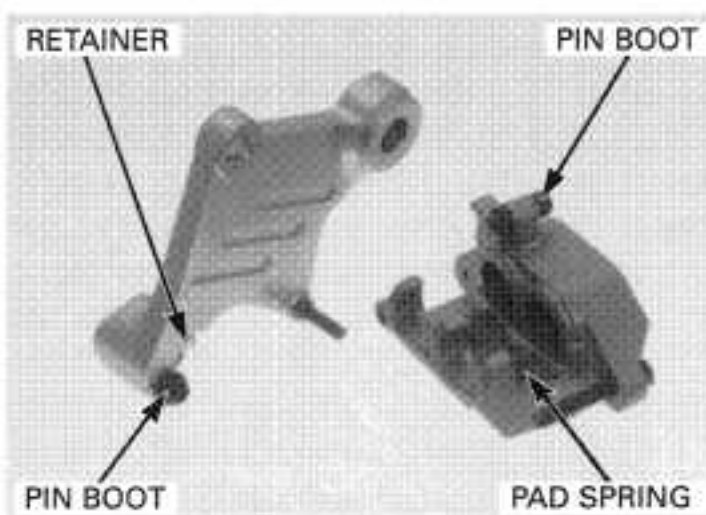

*Do not use high pressure air or bring the nozzle too close to the inlet.*

Place a shop towel over the pistons. Position the caliper body with the pistons down and apply small squirts of air pressure to the fluid inlets to remove the pistons.



*Be careful not to damage the piston sliding surface.*

Push the dust seals and piston seals in and lift them out.

Clean the seal grooves, caliper pistons and caliper piston sliding surfaces with clean brake fluid.

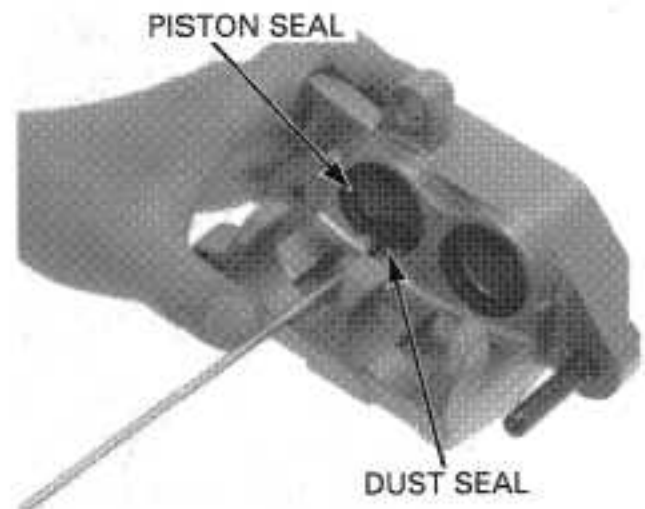

## INSPECTION

Check the caliper cylinder and pistons for scoring, scratches or damage.

Measure the caliper cylinder I.D.

**SERVICE LIMITS: 34.020 mm (1.3394 in)**



Measure the caliper piston O.D.

**SERVICE LIMIT: 33.870 mm (1.3335 in)**

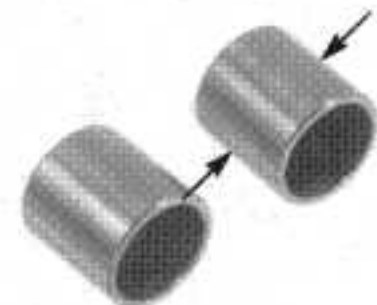

# HYDRAULIC BRAKE

## ASSEMBLY

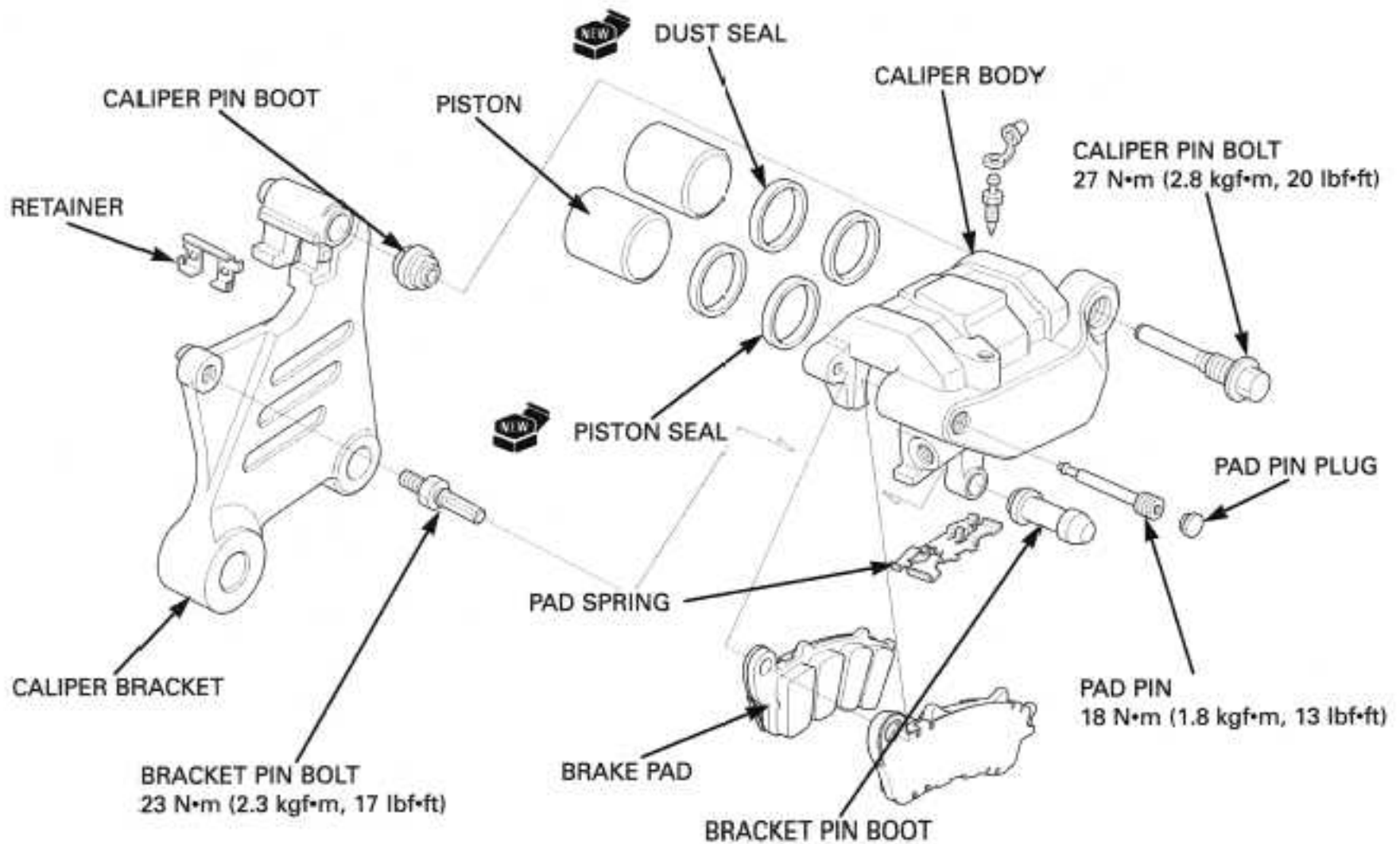

Replace the dust seals and piston seals with new ones.

Apply silicone grease to the boot inner surface. Be sure each part is free from the dust or dirt before reassembly.

Coat a new piston seal with clean brake fluid. Coat a new dust seal with silicone grease. Install the piston seal and dust seal into the groove of the caliper body. Coat the caliper piston with clean brake fluid and install them into the caliper cylinder with their closed ends facing the caliper.

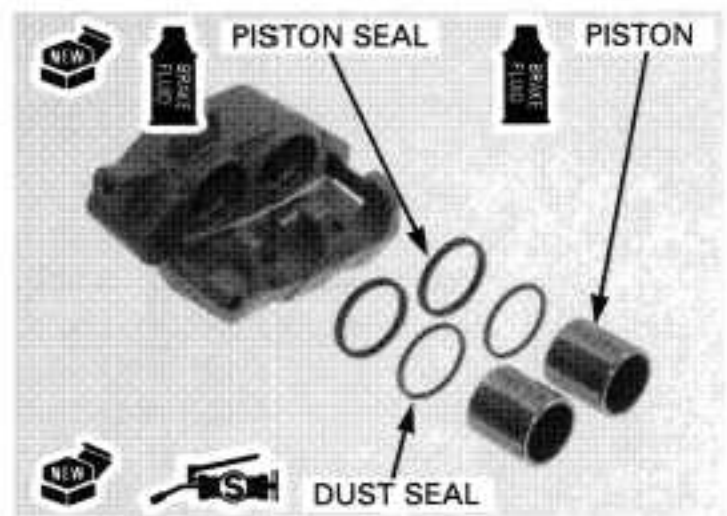

Replace the caliper and bracket pin boots if they are worn, deteriorated or damaged.

Install the pad spring into the caliper body as shown.

Apply silicone grease to the inside of the boot. Install the boot and collar to the caliper.

Apply silicone grease to the boot inside. Install the boot to the caliper bracket.

Install the retainer to the caliper bracket.

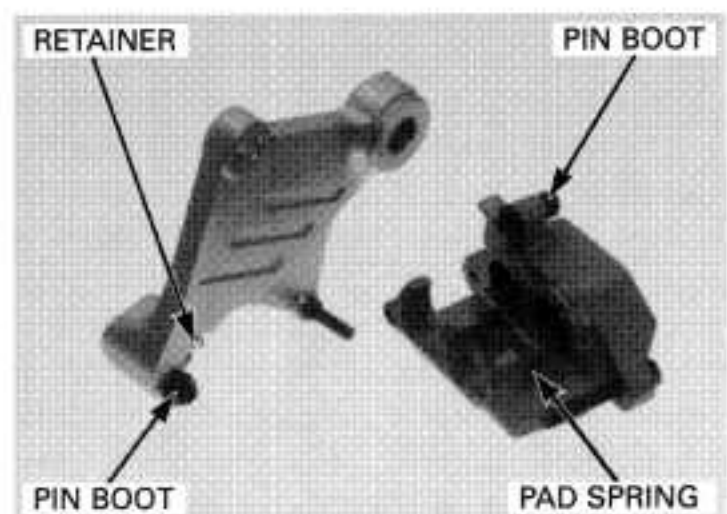



Install the caliper bracket to the caliper.

## INSTALLATION

Install the rear caliper.

Install the rear wheel (page 14-9).  
Install the brake pads (page 15-11).

Install the brake hose eyelets to the caliper body with new sealing washers and oil bolts.  
Push the brake hose eyelet to the stopper on the caliper, then tighten the oil bolts to the specified torque.

**TORQUE: 34 N·m (3.5 kgf·m, 25 lbf·ft)**

Fill and bleed the hydraulic system (page 15-7).

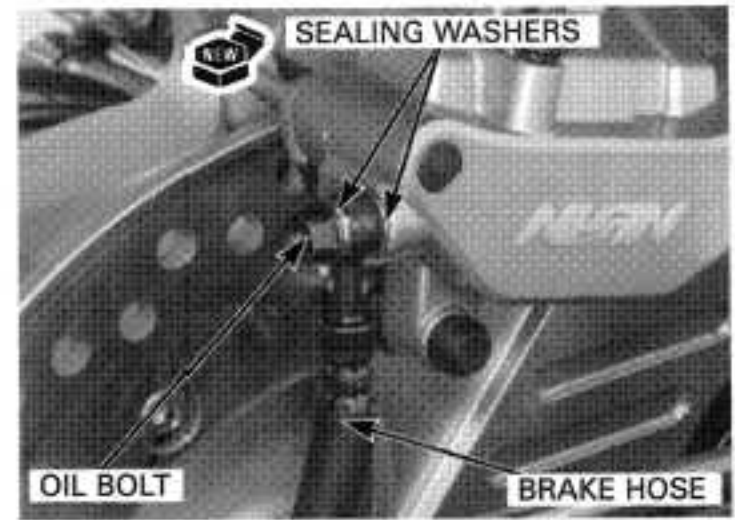
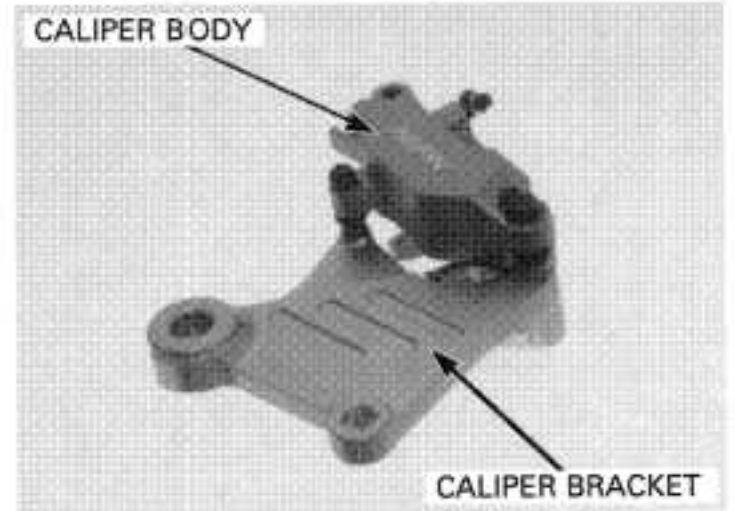

## PCV (Proportional Control Valve)

### REMOVAL/INSTALLATION

Remove the seat (page 2-2).  
Drain the brake fluid from the hydraulic system (page 15-4).

Loosen the brake pipe joint bolts and remove the brake pipes.  
Remove the bolts and PCV.

Installation is in the reverse order of removal.

**TORQUE:**

**Brake pipe joint bolt: 17 N·m (1.7 kgf·m, 1.2 lbf·ft)**

**PCV mounting bolt: 12 N·m (1.2 kgf·m, 9 lbf·ft)**

Fill and bleed the hydraulic system (page 15-5).  
Install the seat (page 2-2).

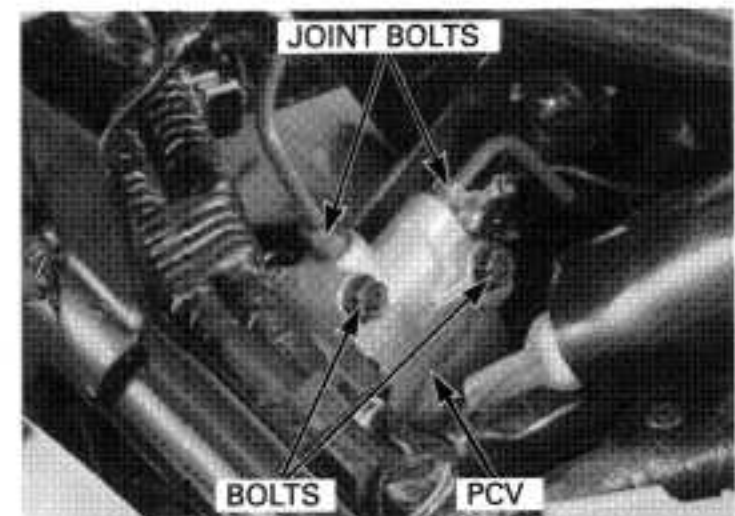



# CHARGING SYSTEM/ALTERNATOR

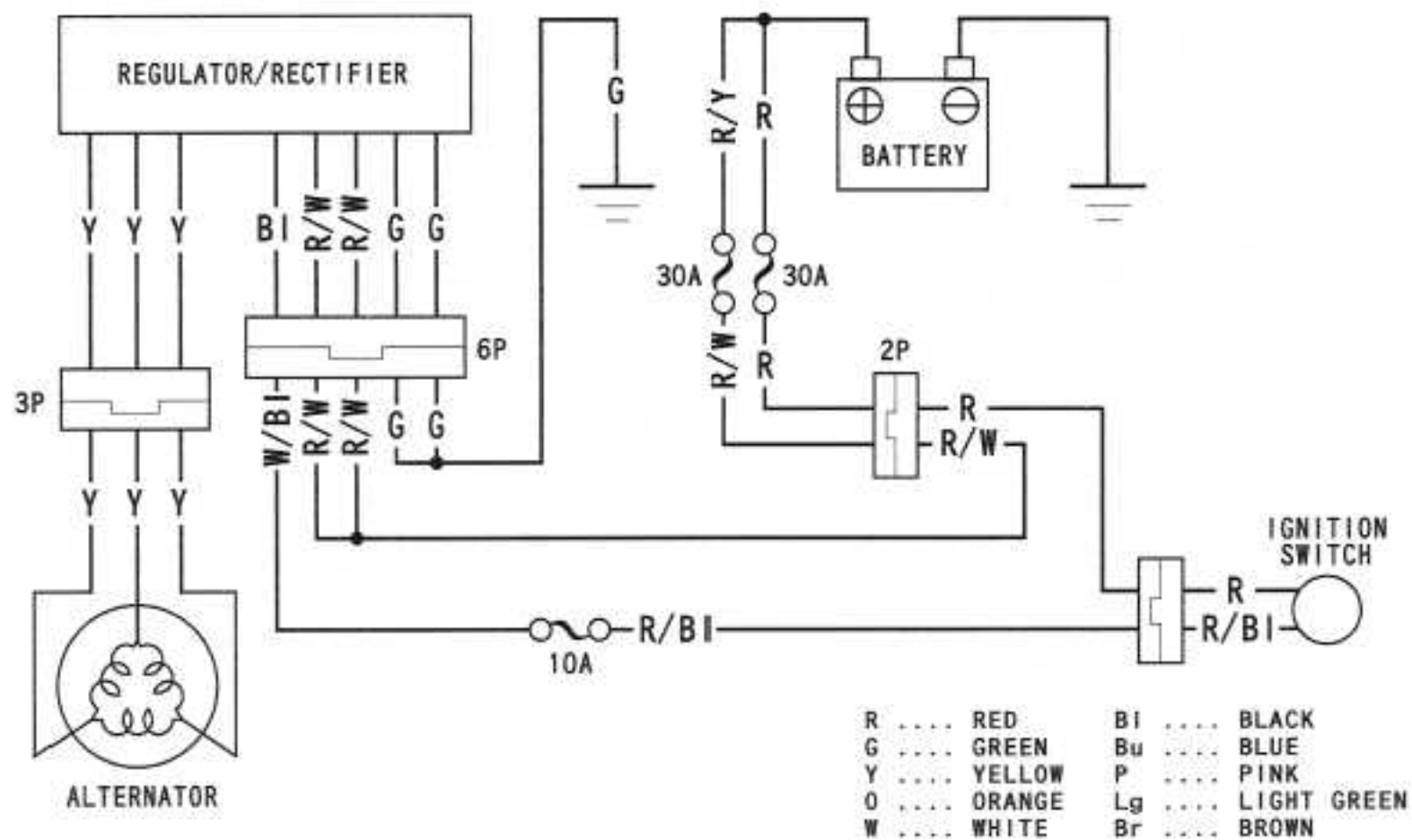
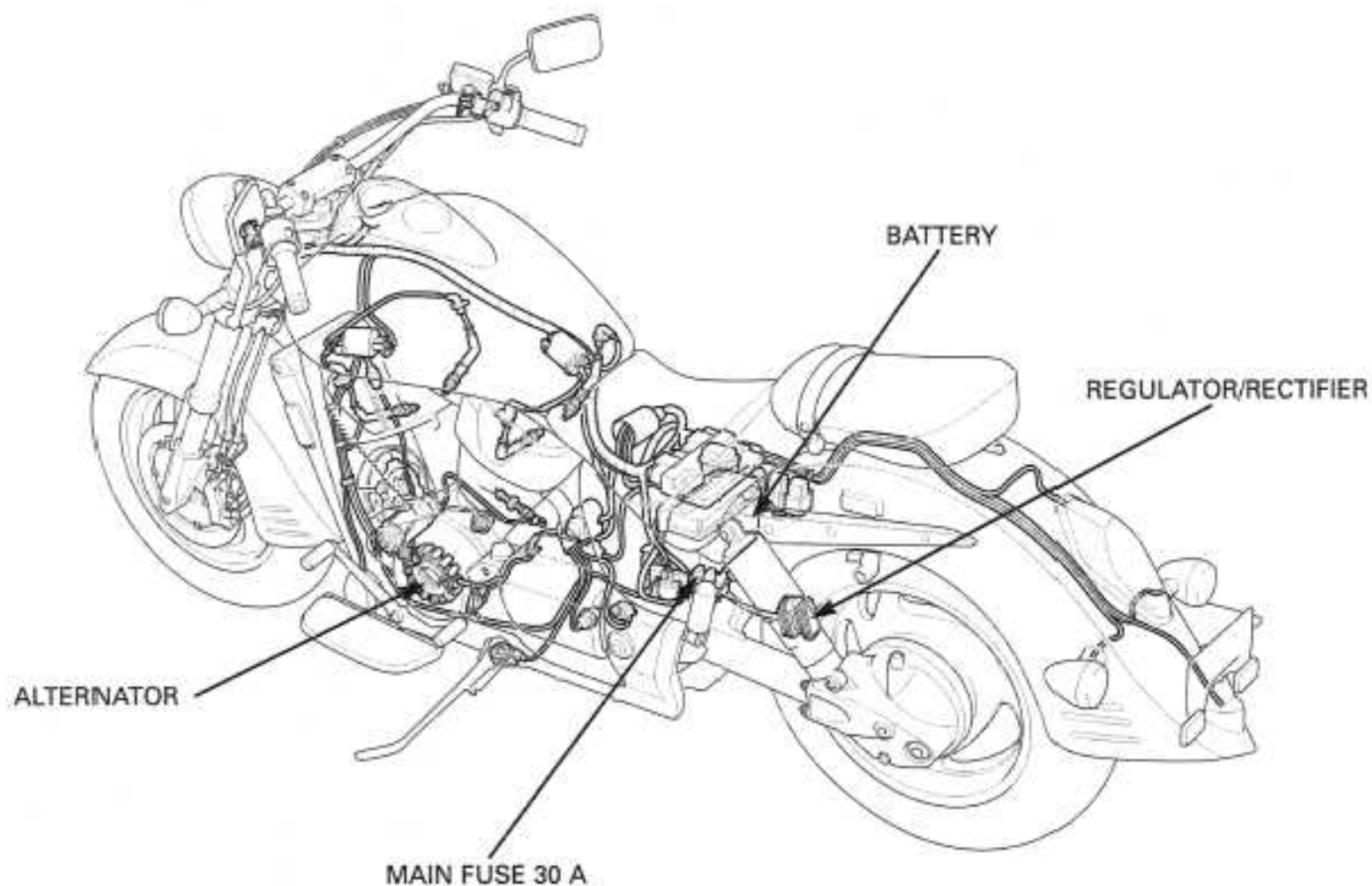

# 16. CHARGING SYSTEM/ALTERNATOR

SERVICE INFORMATION	16-1	BATTERY CASE	16-7
TROUBLESHOOTING	16-3	REGULATOR/RECTIFIER	16-8
BATTERY	16-4	ALTERNATOR	16-9
CHARGING SYSTEM INSPECTION	16-6		

## SERVICE INFORMATION

### GENERAL

#### **⚠ CAUTION**

- The battery gives off explosive gases; keep sparks, flames and cigarettes away. Provide adequate ventilation when charging.
- The battery contains sulfuric acid (electrolyte). Contact with skin or eyes may cause severe burns. Wear protective clothing and a face shield.
  - If electrolyte gets on your skin, flush with water.
  - If electrolyte gets in your eyes, flush with water for at least 15 minutes and call a physician immediately.
- Electrolyte is poisonous.
  - If swallowed, call your local Poison Control Center or physician immediately.

- Always turn off the ignition switch before disconnecting any electrical component.
- Some electrical components may be damaged if terminals or connectors are connected or disconnected while the ignition switch is turned to "ON" and current is present.
- For extended storage, remove the battery, give it a full charge, and store it in a cool, dry place.
- For a battery remaining in a shorted vehicle, disconnect the negative battery cable from the battery.
- The battery caps should not be removed. Attempting to remove the sealing caps from the cells may damage the battery.
- The maintenance free battery must be replaced when it reaches the end of its service life.
- The battery can be damaged if overcharged or undercharged, or if left to discharge for long period. These same conditions contribute to shortening the "life span" of the battery. Even under normal use, the performance of the battery deteriorates after 2 – 3 years.
- Battery voltage may recover after battery charging, but under heavy load, the battery voltage will drop quickly and eventually die out. For this reason, the charging system is often suspected as the problem. Battery overcharge often results from problems in the battery itself, which may appear to be an overcharging symptom. If one of the battery cells is shorted and battery voltage does not increase, the regulator/rectifier supplies excess voltage to the battery. Under these conditions, the electrolyte level goes down quickly.
- Before troubleshooting the charging system, check for proper use and maintenance of the battery. Check if the battery is frequently under heavy load, such as having the headlight and taillight on for long periods of time without riding the vehicle.
- The battery self-discharge when the vehicle is not in use, for this reason, charge the battery every 2 weeks to prevent sulfation from occurring.
- Filling a new battery with electrolyte will produce some voltage, but in order to achieve its maximum performance, always charge the battery. Also, the battery life is lengthened when it is initially charged.
- When checking the charging system, always follow the steps in the troubleshooting flow chart (page 16-3).

**16**

### BATTERY CHARGING

- This model comes with a maintenance free (MF) battery. Remember the following about MF batteries.
  - Use only the electrolyte that comes with the battery
  - Use all of the electrolyte
  - Seal the battery properly
  - Never open the seals again
- For battery charging, do not exceed the charging current and time specified on the battery. Using excessive current or extending the charging time may damage the battery.

## CHARGING SYSTEM/ALTERNATOR

---

### BATTERY TESTING

Refer to the battery tester's Operation Manual for the recommended battery testing procedure.

The recommended battery tester puts a "load" on the battery so the actual battery condition of the load can be measured.

**Recommended battery tester**    **BM-210-AH or BM-210 (U.S.A. only)**

### SPECIFICATION

ITEM		SPECIFICATIONS	
Battery	Capacity	12V – 18 Ah	
	Current leakage	0.1 mA max.	
	Voltage (20°C/68°F)	Fully charged	13.0 – 13.2 V
		Needs charging	Below 12.3 V
	Charging current	Normal	1.8 A/5 – 10 h
Quick		9.0 A/1.0 h	
Alternator	Capacity	0.4 kW/5,000 rpm	
	Charging coil resistance (20°C/68°F)	0.1 – 1.0 Ω	

### TORQUE VALUES

Crankshaft hole cap	18 N•m (1.8 kgf•m, 13 lbf•ft)
Change pedal pinch bolt	12 N•m (1.2 kgf•m, 9 lbf•ft)
Side stand bracket bolt	39 N•m (4.0 kgf•m, 29 lbf•ft)
Step holder bolt	39 N•m (4.0 kgf•m, 29 lbf•ft)

Apply grease to the threads.

# TROUBLESHOOTING

## Battery is damaged or weak

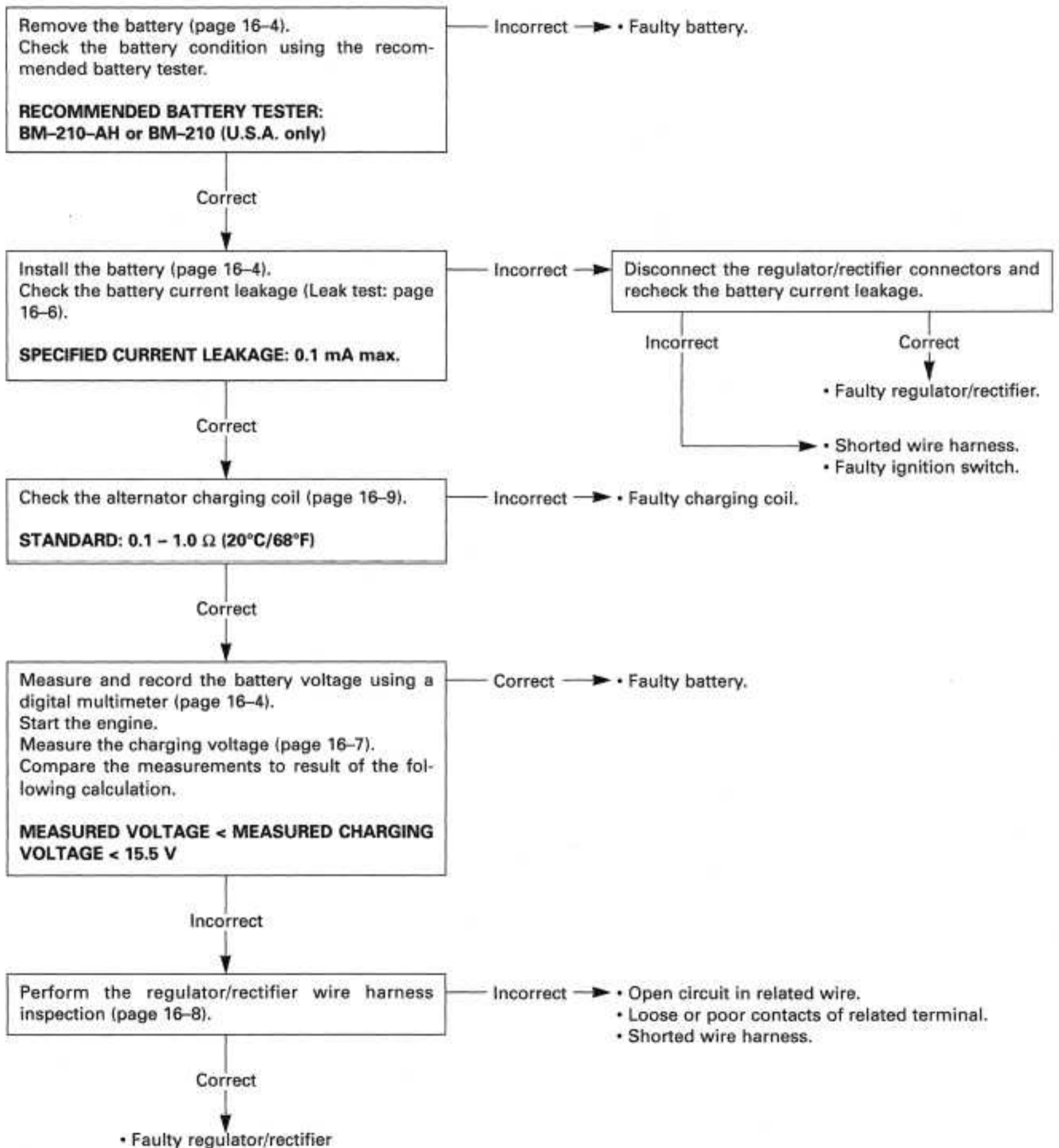

## BATTERY

### REMOVAL

Remove the seat (page 2-2).  
Remove the ECM (page 5-79).

Remove the screws and battery case cover.  
With the ignition switch turned to "OFF", remove the terminal screw and disconnect the negative (-) cable first, then remove the terminal screw and disconnect the positive (+) cable.

Remove the battery from the battery case.

### INSTALLATION

Installation is in the reverse order of removal.

- Connect the positive (+) cable first, then connect the negative (-) cable.
- After connecting the battery cables, coat the terminals with grease.
- Set the positive (+) cable cover to the battery positive (+) terminal properly and do not expose the battery positive (+) terminal or cable.

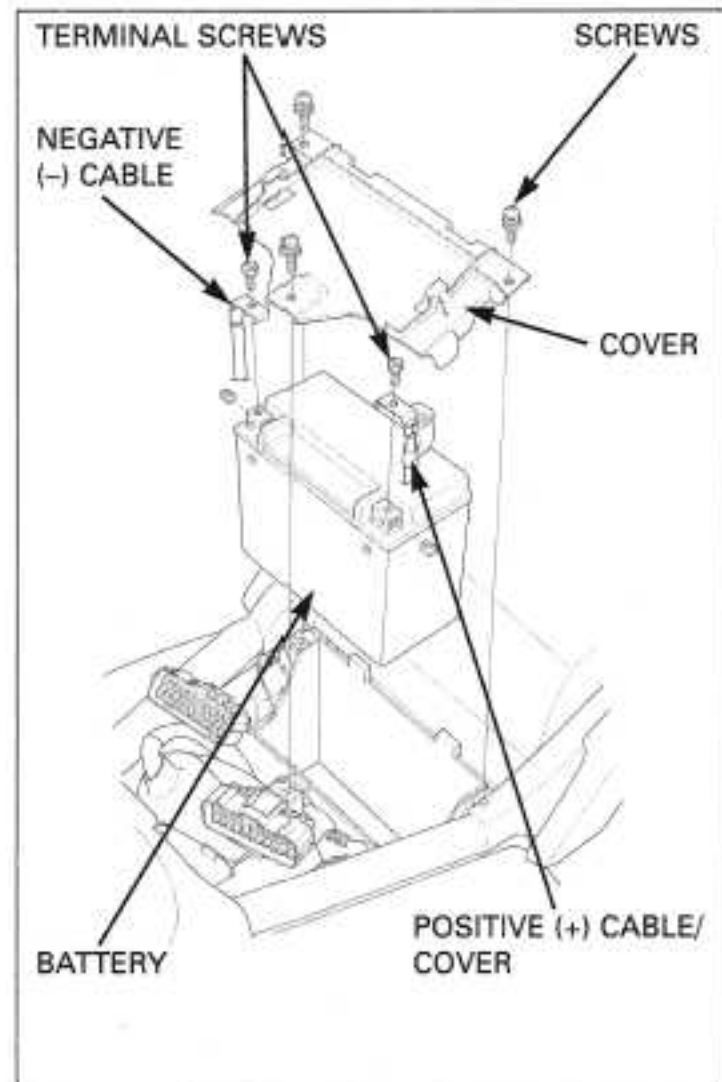

### VOLTAGE INSPECTION

Remove the seat (page 2-2).  
Remove the ECM (page 5-79).

Measure the battery voltage using a commercially available digital multimeter.

**VOLTAGE (20°C/68°F):**  
Fully charged: 13.0 - 13.2 V  
Under charged: Below 12.3 V

**TOOL:**  
Digital multimeter Commercially available

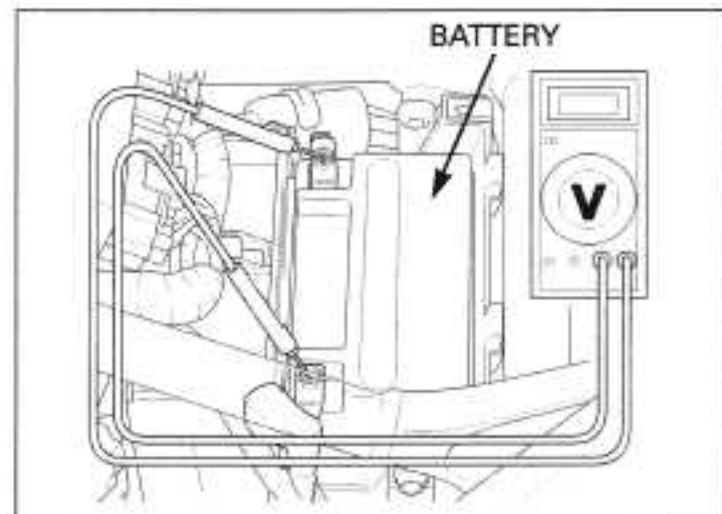

### BATTERY TESTING

- Always clear the work area of flammable materials such as gasoline, brake fluid, electrolyte, or cloth towels when operating the tester, the heat generated by the tester may cause a fire.

Remove the battery (see above).

Securely connect the tester's positive (+) cable first, then connect the negative (-) cable.

**TOOL:**  
Battery tester BM-210-AH or BM-210 (U.S.A. only)

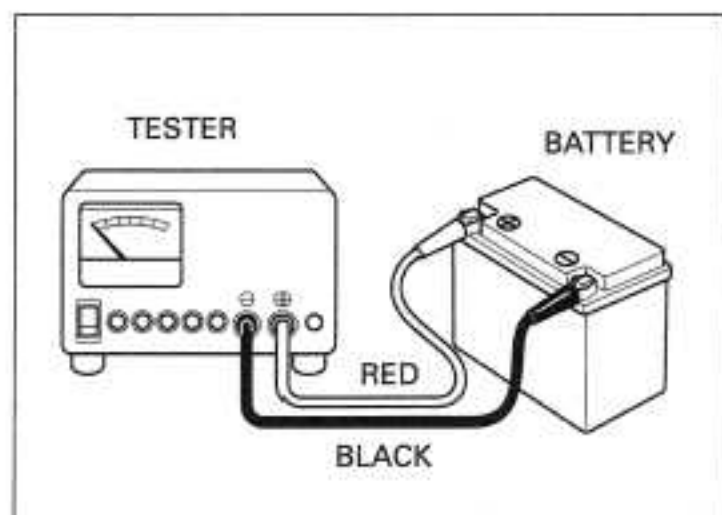



*For accurate test results, be sure the tester's cables and clamps are in good working condition and that a secure connection can be made at the battery.*

Set the temperature switch to "HIGH" or "LOW" depending on the ambient temperature.

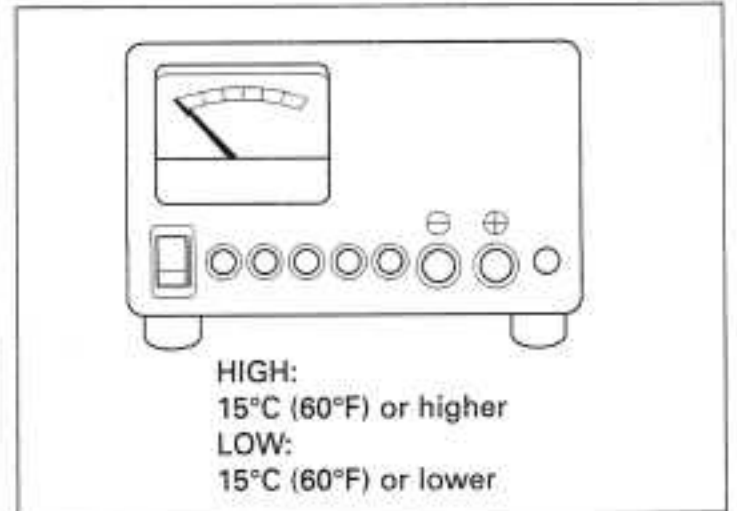

*For the first check, DO NOT charge the battery before testing; test it in an "as is" condition.*

Push in the appropriate test button for 3 seconds and read the condition of the battery on the meter.

Tester damage can result from overheating when:

- The test button is pushed in for more than 3 seconds.
- The tester is used without being allowed to cool for at least 1 minute when testing more than one battery.
- More than ten consecutive tests are performed without allowing at least a 30-minute cool-down period.

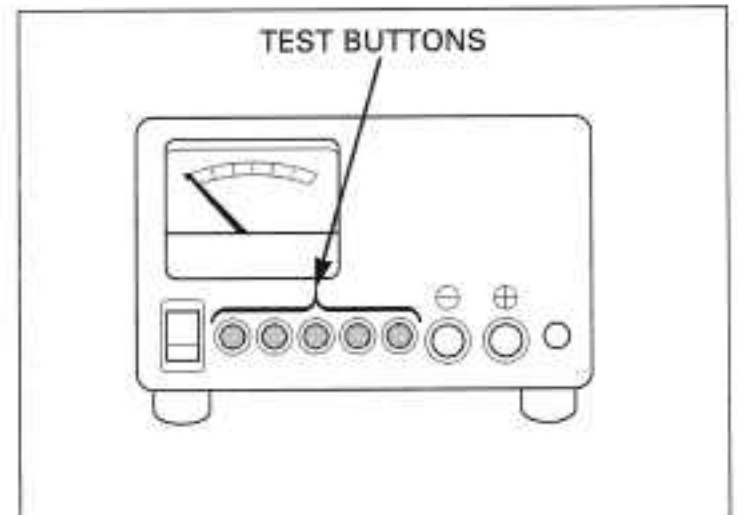

The result of a test on the meter scale is relative to the amp. hour rating of the battery. Any battery reading in the green zone is ok. Batteries should only be charged if they register in the YELLOW or RED zone.

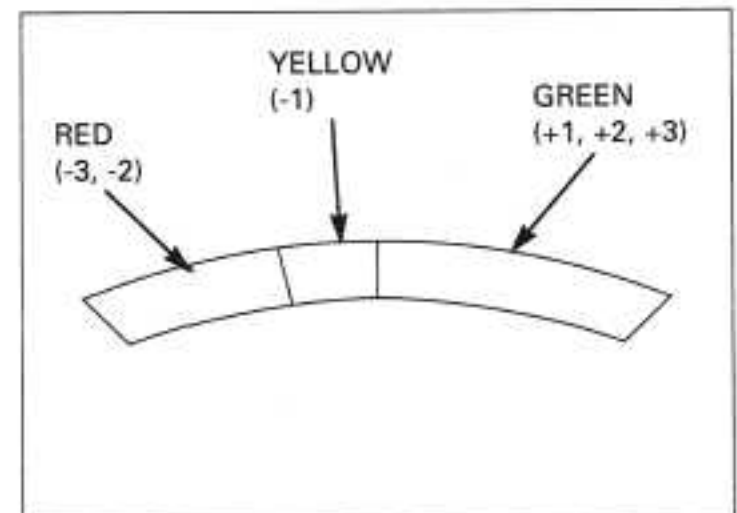

### BATTERY CHARGING

Remove the battery (page 16-4).

- Clean the battery terminals and position the battery as far away from the charger as the leads will permit.
- Do not place batteries below the charger – gases from the battery may corrode and damage the charger.
- Do not place batteries on top of the charger. Be sure the air vents are not blocked.

## CHARGING SYSTEM/ALTERNATOR

### TOOL:

Christie battery charger MC1012/2 (U.S.A. only)

1. Turn the "POWER" switch to "OFF".
2. Set the "BATTERY AMP HR. SELECTOR SWITCH" for the size of the battery being charged.
3. Set the "TIMER" to the position indicated by the Honda Battery Tester; RED-3, RED-2 or YELLOW 1. If you are charging a new battery, set the switch to the "NEW BATT" position.
4. Attach the clamps to the battery terminals: red to positive, black to negative.

Connect the battery cables only when the Power Switch is OFF.

5. Turn the "POWER" switch to "ON".
6. When the timer reaches the "Trickle" position, the charging cycle is complete. Turn the "POWER" switch to "OFF" and disconnect the clamps.
7. Let the battery cool for at least 10 minutes or until gassing subsides after charging.
8. Retest the battery using the Honda battery tester and recharge if necessary using the above steps.

*The charger will automatically switch to the "Trickle" mode after the set charging time has elapsed.*

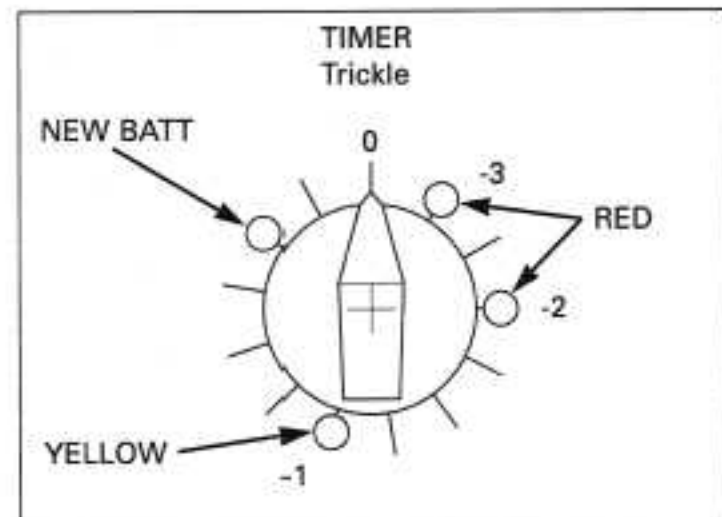
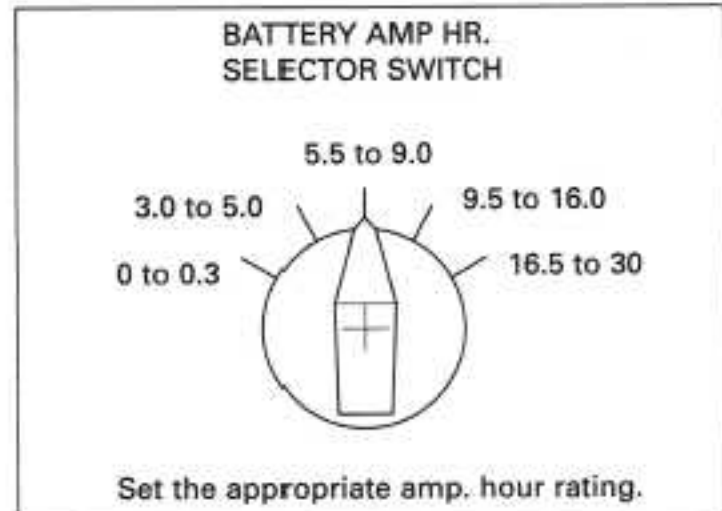

## CHARGING SYSTEM INSPECTION

Remove the seat (page 2-2).  
Remove the ECM (page 5-79).

### CURRENT LEAKAGE TEST

Turn the ignition switch to "OFF", and disconnect the negative (-) cable from the battery.

Connect the ammeter (+) probe to the negative (-) cable and ammeter (-) probe to the battery (-) terminal.

With the ignition switch turned to "OFF", check for current leakage.

- When measuring current using a tester, set it to a high range, and then bring the range down to an appropriate level. Current flow higher than the range selected may blow out the fuse in the tester.
- While measuring current, do not turn the ignition switch to "ON". A sudden surge of current may blow out the fuse in the tester.

**SPECIFIED CURRENT LEAKAGE: 0.1 mA max.**

If current leakage exceeds the specified value, a shorted circuit is likely.

Locate the short by disconnecting connections one by one and measuring the current.

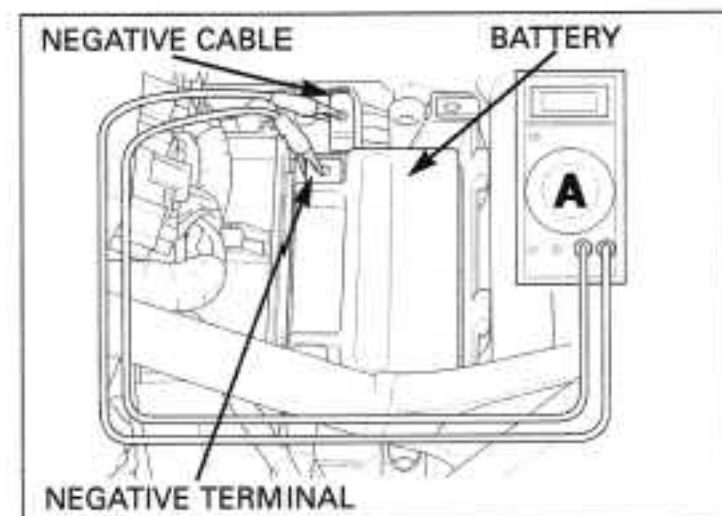

## CHARGING VOLTAGE INSPECTION

Be sure that the battery is in good condition before performing this test.

*Do not disconnect the battery or any cable in the charging system without first switching off the ignition switch. Failure to follow this precaution can damage the tester or electrical components.*

Start the engine and warm it up to the operating temperature; stop the engine. Connect the multimeter between the positive and negative terminals of the battery.

To prevent a short, make absolutely certain which are the positive and negative terminals of cable.

With the headlight on the high beam, restart the engine.

Measure the voltage on the multimeter when the engine runs at 5,000 rpm.

### STANDARD:

Measured battery voltage (page 15-4) < Measured charging voltage (see above) < 15.5 V

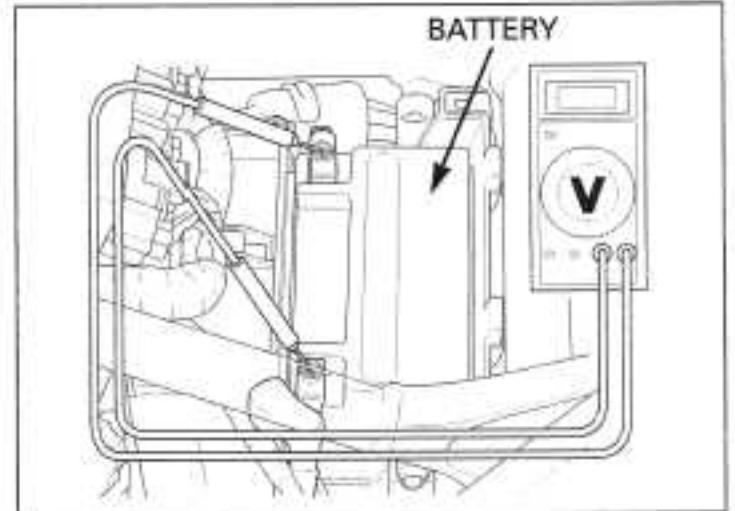

## BATTERY CASE

### REMOVAL/INSTALLATION

Remove the battery (page 16-4).  
 Disconnect the BARO sensor 3P connector (page 5-73).  
 Disconnect the bank angle sensor 3P green connector (page 5-77).

Remove the screws and tool box cover.

Remove the bolts and battery case.

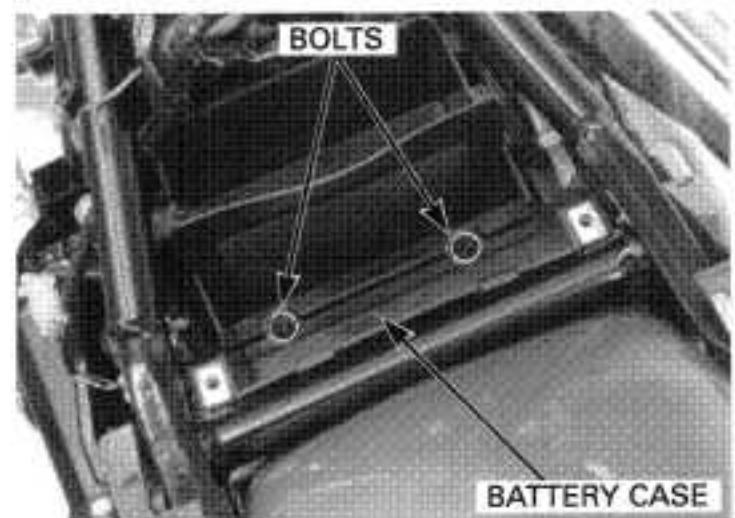
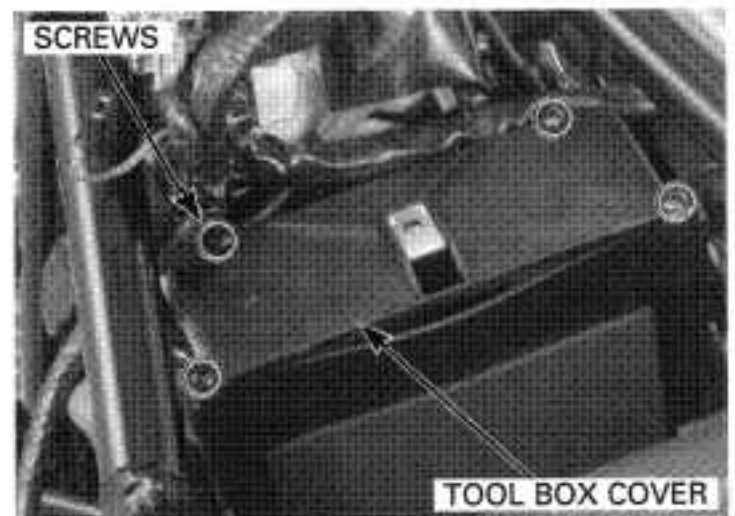

**REGULATOR/RECTIFIER**

**WIRE HARNESS INSPECTION**

Remove the seat (page 2-2).  
Remove the left crankcase rear cover (page 2-3).

Disconnect the regulator/rectifier 6P and alternator 3P connectors.

Check the connectors for loose or corroded terminals.

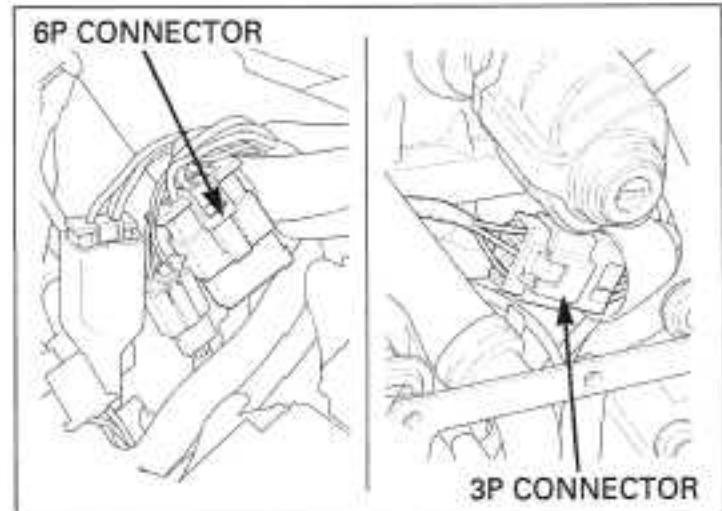

**BATTERY LINE**

Measure the voltage between the Red/white wire terminals of the wire harness side and ground. There should be battery voltage at all times.

**GROUND LINE**

Check the continuity between the Green wire terminals of the wire harness side and ground. There should be continuity at all times.

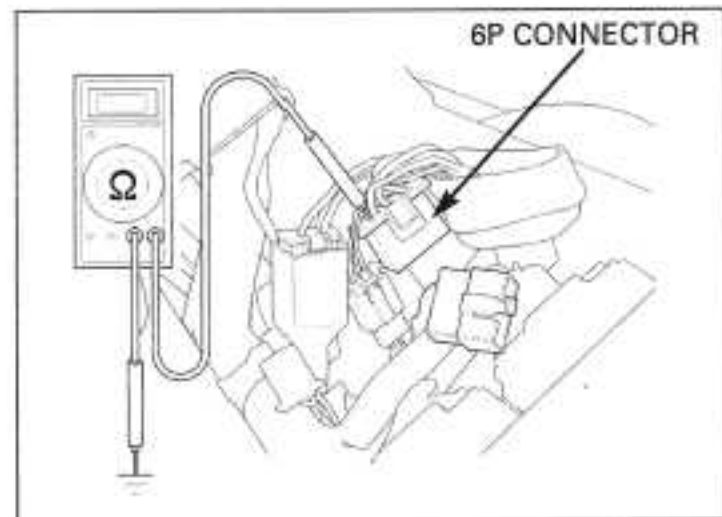

**CHARGING COIL LINE**

Measure the resistance between the Yellow wire terminals of the wire harness side.

**STANDARD: 0.1 – 1.0  $\Omega$  (20 °C/68 °F)**

Check for continuity between each Yellow wire terminal of the wire harness side and ground. There should be no continuity.

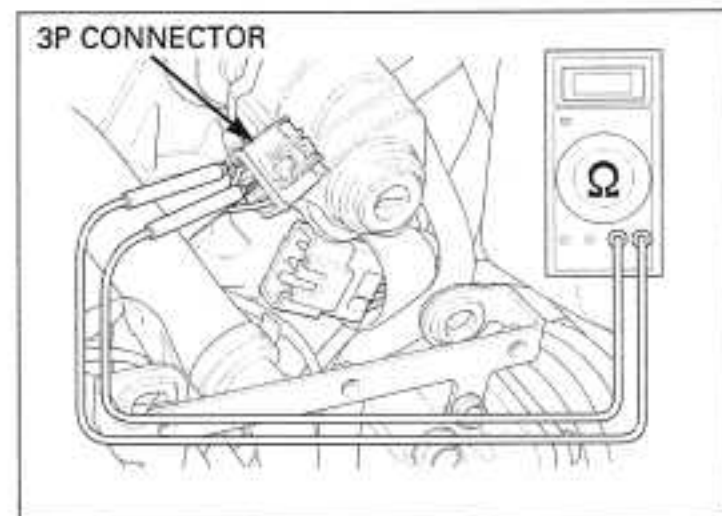

**REMOVAL/INSTALLATION**

Remove the seat (page 2-2).  
Remove the left crankcase rear cover (page 2-3).

Disconnect the regulator/rectifier 6P and alternator 3P connectors.

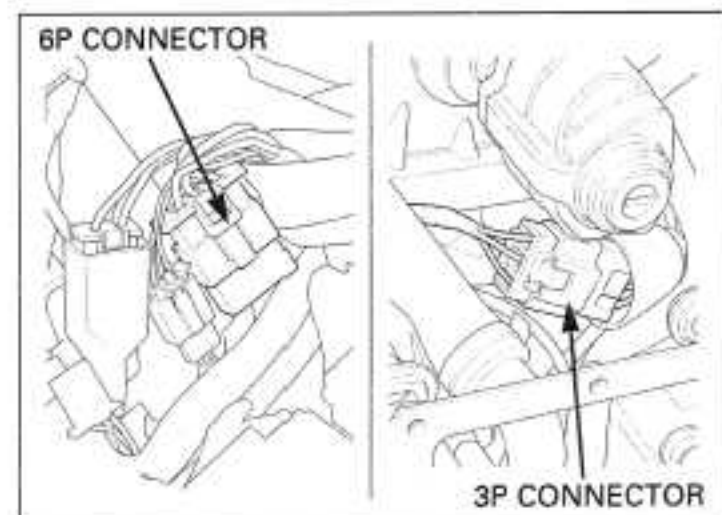



Remove the bolts and the regulator/rectifier.  
 Installation is in the reverse order of removal.

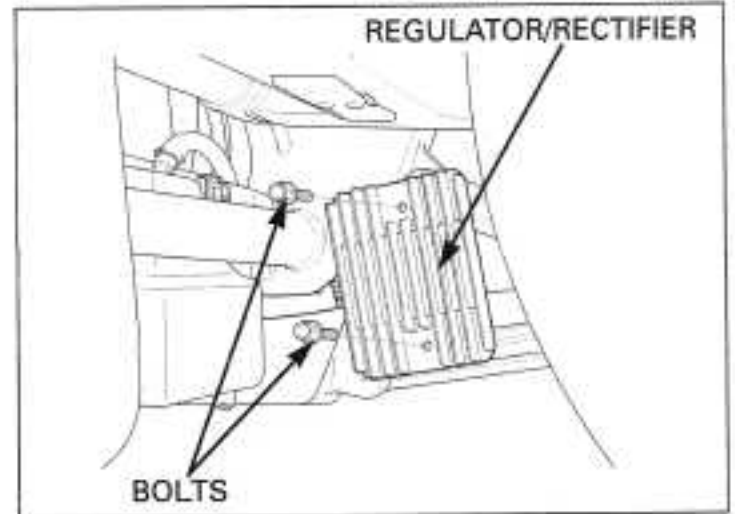

## ALTERNATOR

### INSPECTION

Remove the left crankcase rear cover (page 2-3).  
 Disconnect the alternator 3P connector.

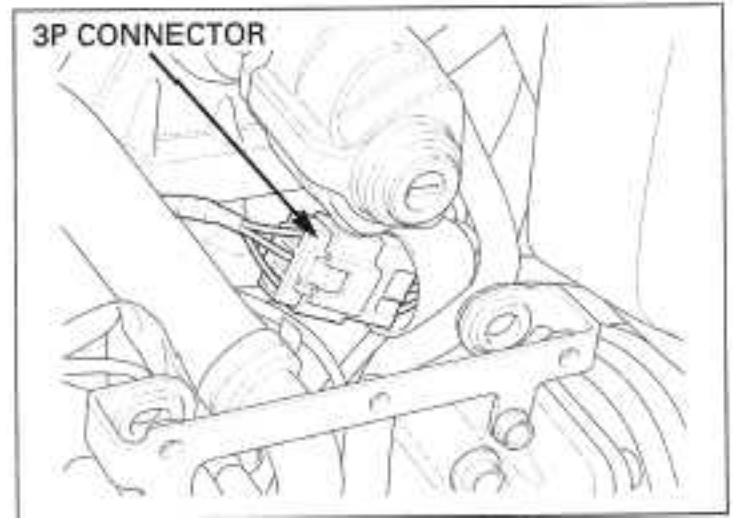

Measure the resistance between Yellow wire terminals of the wire harness side.

**STANDARD: 0.1 – 1.0  $\Omega$  (20 °C/68 °F)**

Check for continuity between each Yellow wire terminal of the wire harness side and ground. There should be no continuity.

Replace the alternator stator if resistance is out of specification, or if any wire has continuity to ground.

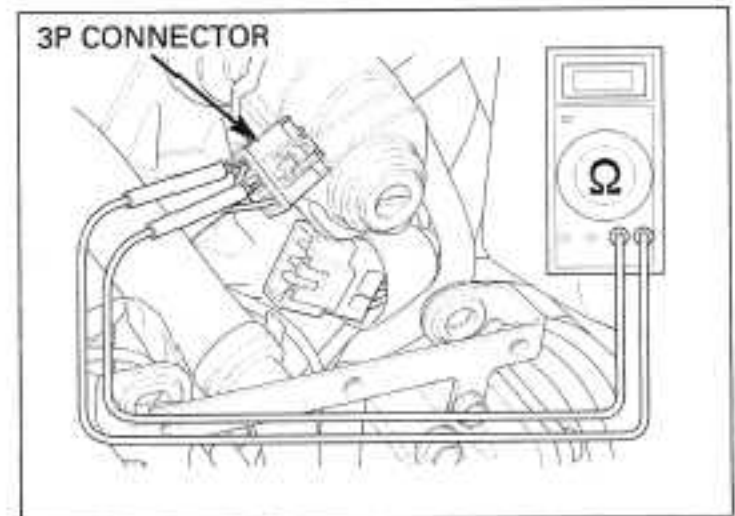

### LEFT CRANKCASE COVER REMOVAL

Remove the left crankcase rear cover (page 2-3).  
 Remove the slave cylinder (page 10-11).  
 Disconnect the alternator 3P and 2P connectors.

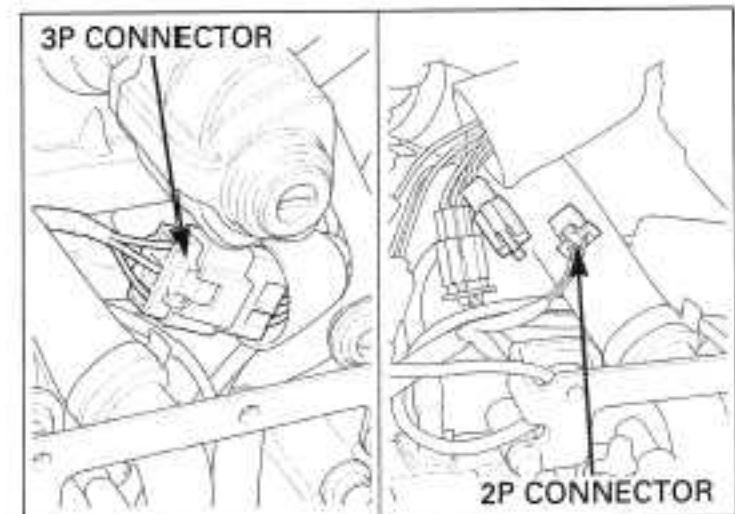



## CHARGING SYSTEM/ALTERNATOR

Remove the pinch bolt and the gearshift arm from the gearshift spindle.

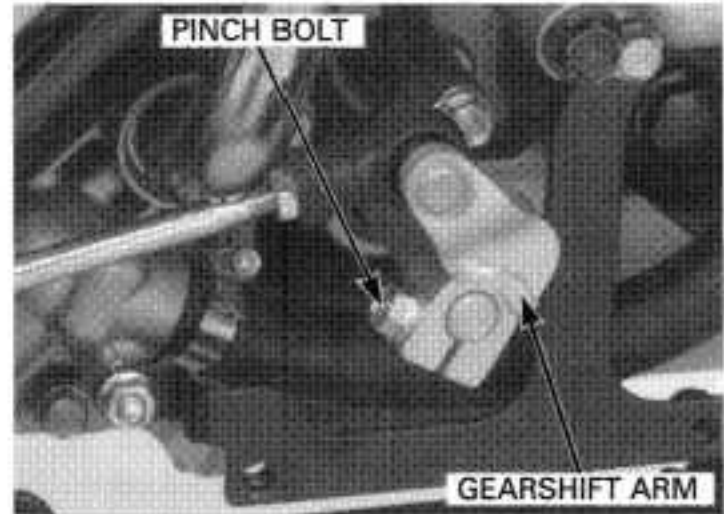

Disconnect the horn connectors (page 19-19).

Remove the bolts and left step holder.

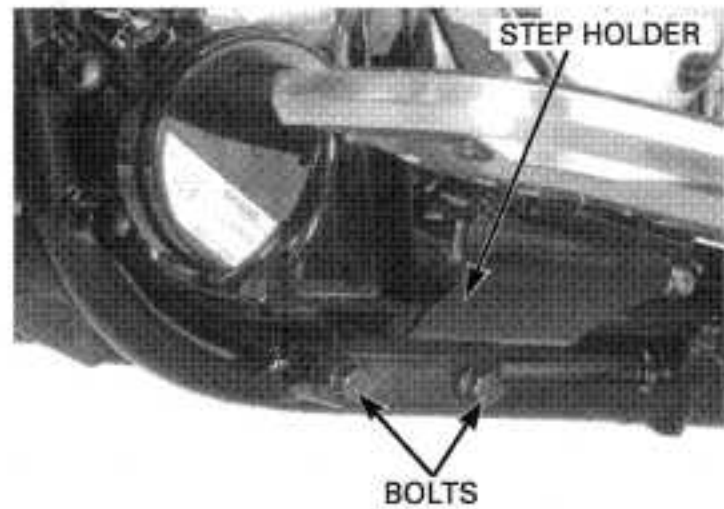

Disconnect the side stand switch 2P green connector (page 19-17).

Remove the bolts and side stand.

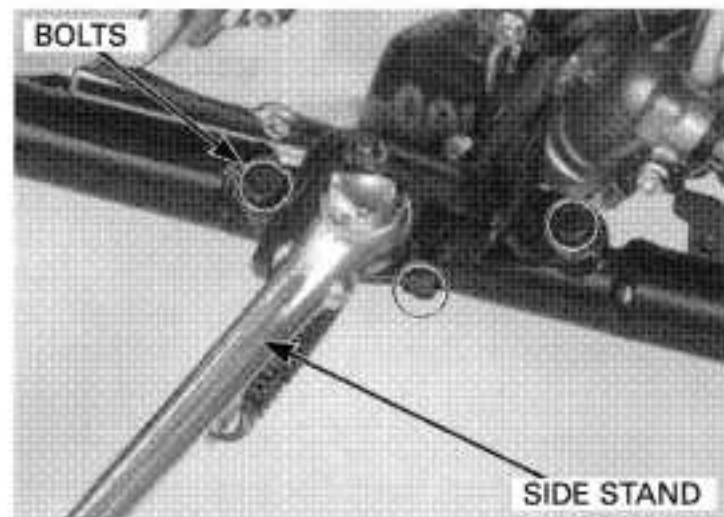

Remove the starter motor cable from the clamps.  
Remove the bolts and left crankcase cover.

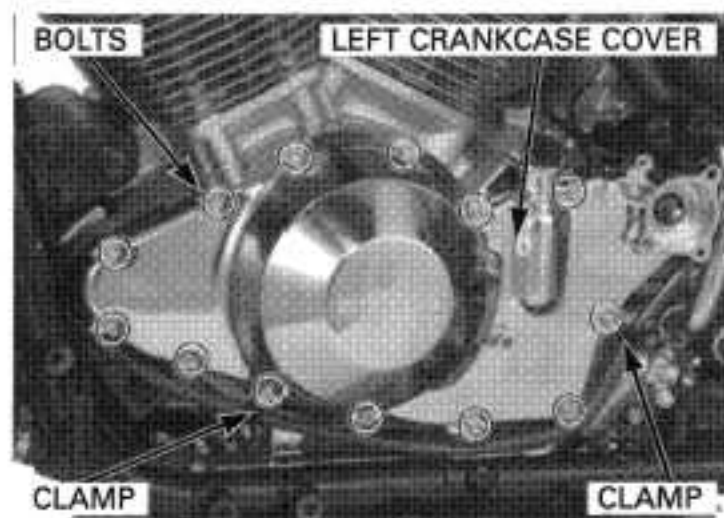

Remove the dowel pins.

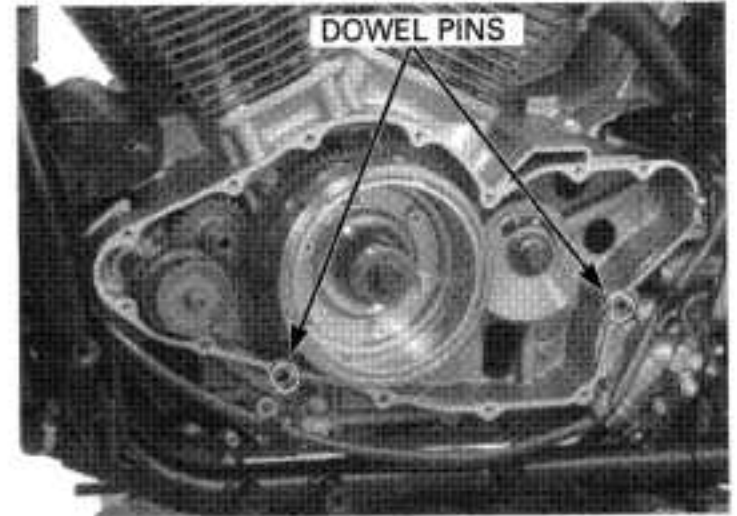

### STATOR REMOVAL/INSTALLATION

#### REMOVAL

Remove the clamp bolts and clamp.

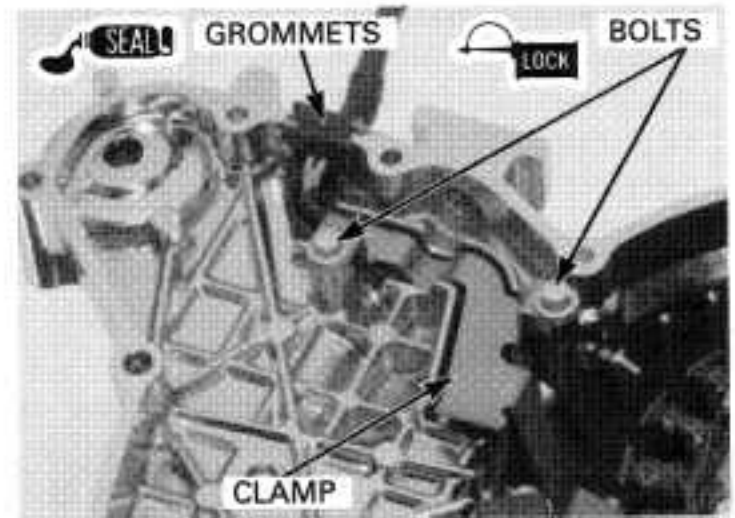

Remove the stator bolts and wire grommets, then remove the stator and ignition pulse generator from the left crankcase cover.

#### INSTALLATION

Clean the mating surfaces of the left crankcase cover and left crankcase.

Install the stator onto the left crankcase cover.

Apply liquid sealant to the wire grommets seating surface and install the grommets into the grooves in the left crankcase cover.

Route the wires properly and install the clamp with the bolts.

Apply locking agent to the stator bolt threads, and install and tighten them.

Apply locking agent to the ignition pulse generator bolt threads, and install and tighten them.

Apply locking agent to the bolt threads  
Install the clamp and tighten the clamp bolt securely.

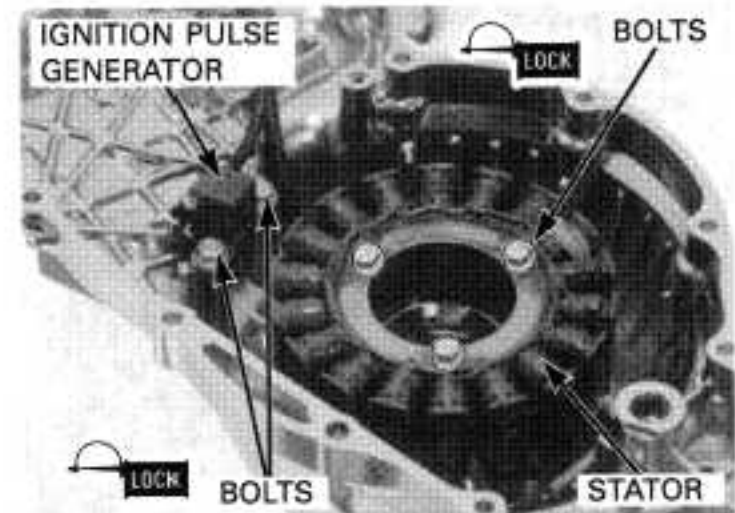

*Be careful not to damage the left crankcase and cover mating surfaces.*

### LEFT CRANKCASE COVER INSTALLATION

Clean the mating surfaces of the left crankcase cover and left crankcase.

Apply sealant to the left crankcase cover mating surface.

*Be careful not to damage the left crankcase and cover mating surfaces.*

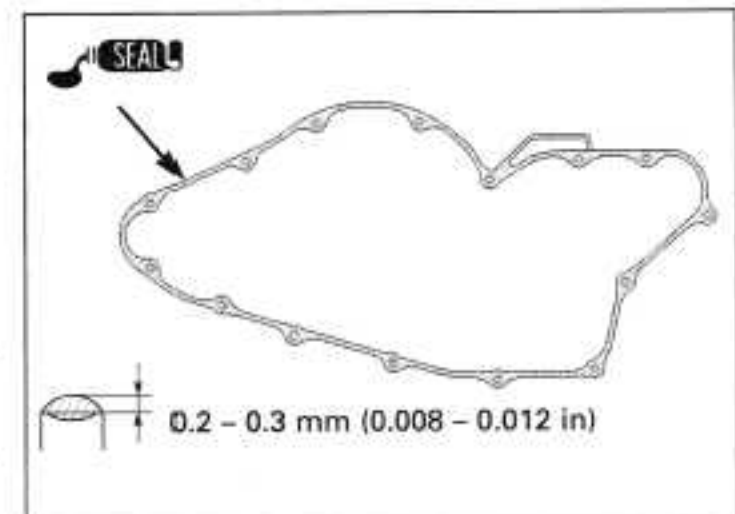

## CHARGING SYSTEM/ALTERNATOR

Install the dowel pins to the left crankcase.

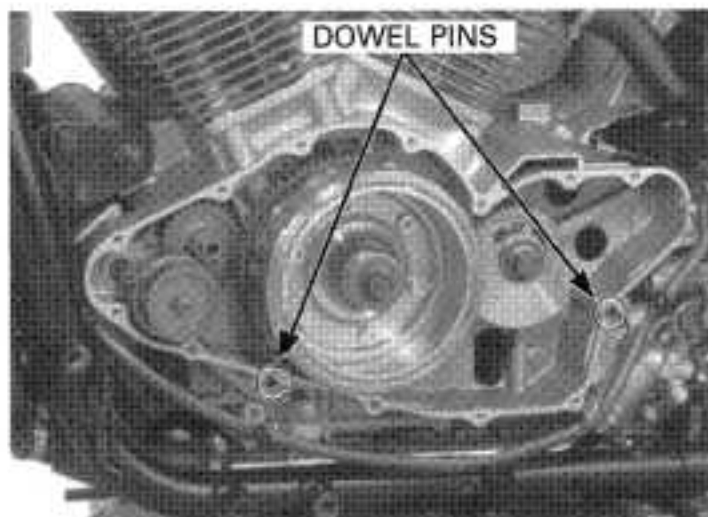

Install the left crankcase cover.  
Install the clamps and tighten the bolts securely.

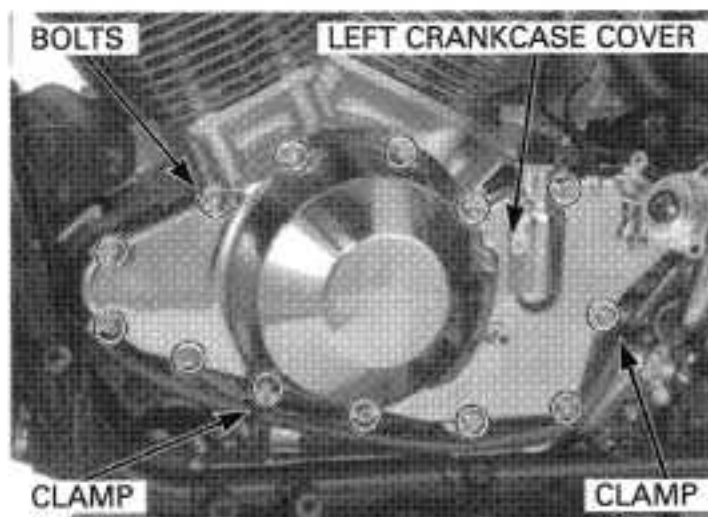

Install the starter motor cable to the clamps.

Install the side stand and tighten the side stand bracket bolts to the specified torque.

**TORQUE: 39 N·m (4.0 kgf·m, 29 lbf·ft)**

Connect the side stand switch 2P green connector (page 19-17).

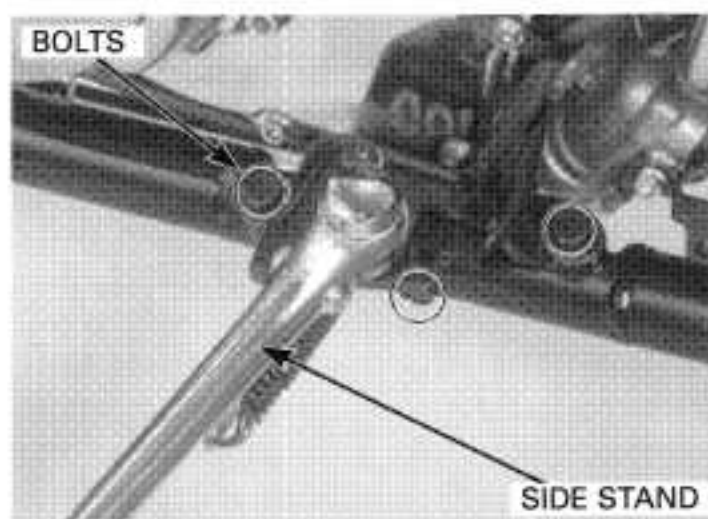

Install the left step holder.  
Install and tighten the left step holder bolts to the specified torque.

**TORQUE: 39 N·m (4.0 kgf·m, 29 lbf·ft)**

Connect the horn connectors (page 19-19).

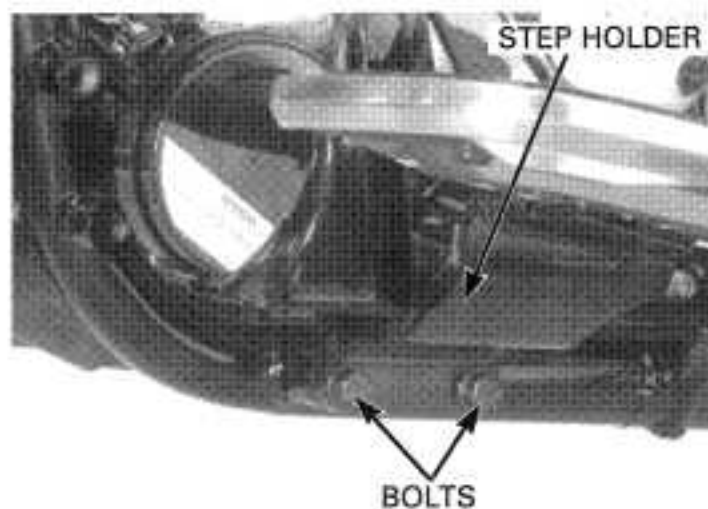

Install the gearshift arm onto the spindle, aligning the slit in the arm with the punch mark on the spindle.

Tighten the change pedal pinch bolt to the specified torque.

**TORQUE: 12 N·m (1.2 kgf·m, 9 lbf·ft)**

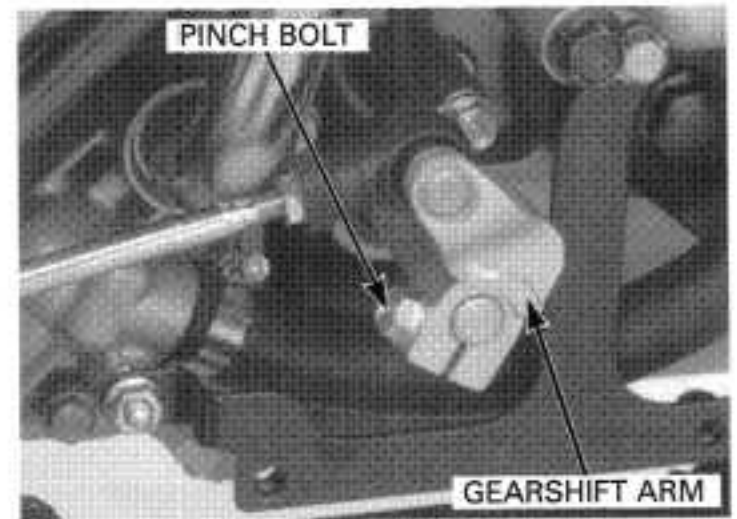

Connect the alternator 3P and 2P connectors.

Install the slave cylinder (page 10–12).

Install the left crankcase rear cover (page 2–3).

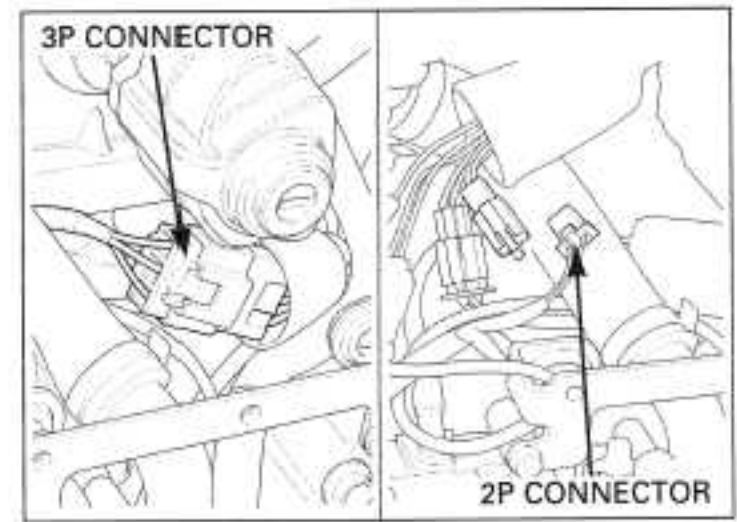



# IGNITION SYSTEM

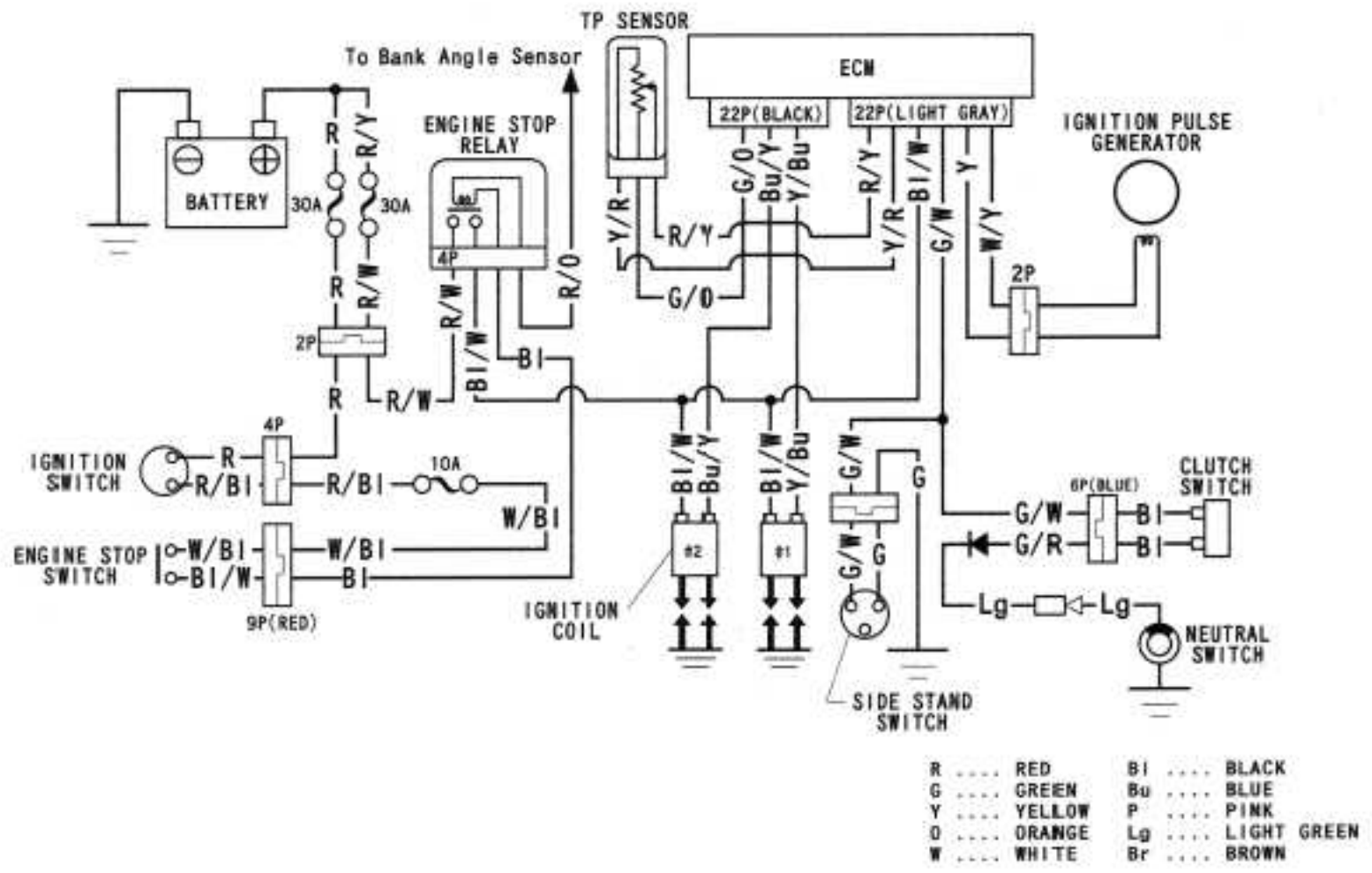
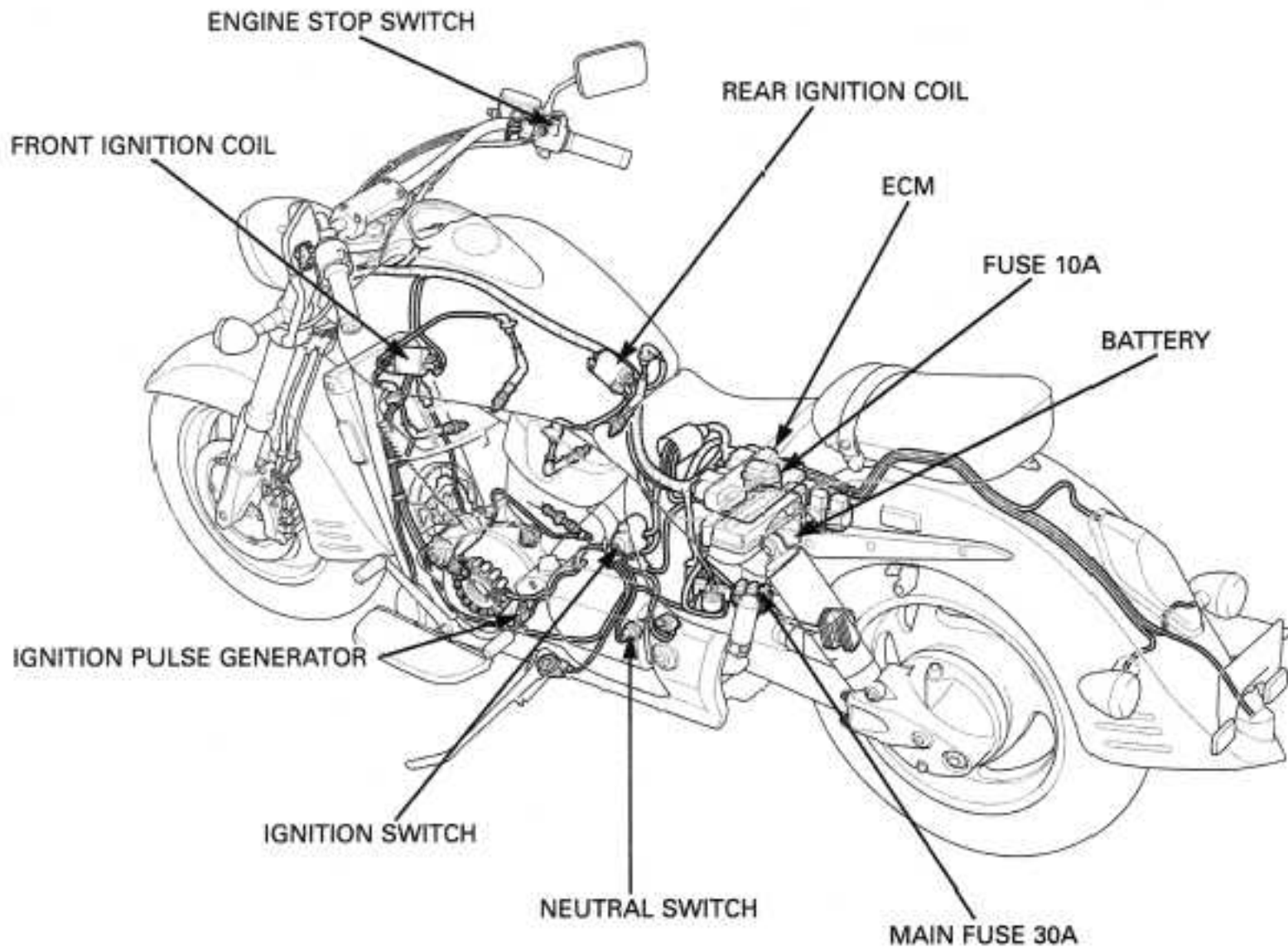



# 17. IGNITION SYSTEM

SERVICE INFORMATION	17-1	IGNITION COIL	17-5
TROUBLESHOOTING	17-2	IGNITION TIMING	17-5
IGNITION SYSTEM INSPECTION	17-3		

## SERVICE INFORMATION

### GENERAL

- Some electrical components may be damaged if terminals or connectors are connected or disconnected while the ignition switch is turned to "ON" and current is present.
- When servicing the ignition system, always follow the steps in the troubleshooting sequence on page 17-2.
- The ignition timing cannot be adjusted since the Engine Control Module (ECM) is factory preset.
- The ECM may be damaged if dropped. Also, if the connector is disconnected when current is flowing, the excessive voltage may damage the ECM. Always turn the ignition switch to "OFF" before servicing.
- A faulty ignition system is often related to poor connected or corroded connectors. Check those connections before proceeding.
- Some electrical components may be damaged if terminals or connectors are connected or disconnected while the ignition switch is turned to "ON" and current is present.
- Use a spark plug of the correct heat range. Using a spark plug with an incorrect heat range can damage the engine.
- For ignition switch and engine stop switch inspection, refer to Section 19.
- For side stand and neutral switch inspection, see Section 19.
- For ECM removal/installation, see page 5-79.

### SPECIFICATION

ITEM		SPECIFICATIONS	
Spark plug	Standard	IFR6L11 (NGK)	VK20PRZ11 (DENSO)
	For cold climate/below 5°C/41°F	IFR5L11 (NGK)	VK16PRZ11 (DENSO)
	For extended high speed riding	IFR7L11 (NGK)	VK22PRZ11 (DENSO)
Spark plug gap		1.0 – 1.1 mm (0.039 – 0.043 in)	
Ignition coil peak voltage		100 V minimum	
Ignition pulse generator peak voltage		0.7 V minimum	
Ignition timing ("F" mark)		8° BTDC at idle	

### TORQUE VALUES

Crankshaft hole cap 18 N•m (1.8 kgf•m, 13 lbf•ft) Apply grease to the threads.

## TROUBLESHOOTING

- Inspect the following before diagnosing the system.
  - Faulty spark plug
  - Loose spark plug cap or spark plug wire connection
  - Water got into the spark plug cap (leaking the ignition coil secondary voltage)
- If there is no spark at either cylinder, temporarily exchange the ignition coil with a known-good one and perform the spark test. If there is a spark, the exchanged ignition coil is faulty.
- “Initial voltage” of the ignition primary coil is the battery voltage with the ignition switch turned to “ON” and the engine stop switch turned to “○”. (the engine is not being cranked by the starter motor)

### No spark at spark plugs

Unusual condition		Probable cause (check in numerical order)
Ignition coil primary voltage	No initial voltage with ignition and engine stop switches on. (other electrical components are normal)	<ol style="list-style-type: none"> <li>1. Faulty engine stop switch.</li> <li>2. An open circuit in Black/white wire between the ignition coil and engine stop switch.</li> <li>3. Loose primary terminal or an open circuit in primary coil.</li> <li>4. Faulty ECM (in case when the initial voltage is normal while disconnecting ECM connector).</li> </ol>
	Initial voltage is normal, but it drops down to 2 – 4 V while cranking the engine.	<ol style="list-style-type: none"> <li>1. Incorrect peak voltage adapter connections.</li> <li>2. Undercharged battery.</li> <li>3. No voltage between the Black/white (+) and body ground (-) at the ECM multi-connector or loosen ECM connection.</li> <li>4. An open circuit or loose connection in Green wire.</li> <li>5. An open circuit or loose connection in Blue/yellow and Yellow/blue wire between the ignition coils and ECM.</li> <li>6. Short circuit in ignition primary coil.</li> <li>7. Faulty side stand switch.</li> <li>8. An open circuit or loose connection in No.7 related circuit wires (Green/white and Green wires).</li> <li>9. Faulty ignition pulse generator (measure the peak voltage).</li> <li>10. Faulty ECM (in case when above No. 1 – 9 are normal).</li> </ol>
	Initial voltage is normal, but no peak voltage while cranking the engine.	<ol style="list-style-type: none"> <li>1. Faulty peak voltage adapter connections.</li> <li>2. Faulty peak voltage adapter.</li> <li>3. Faulty ECM (in case when above No.1, 2 are normal).</li> </ol>
	Initial voltage is normal, but peak voltage is lower than standard value.	<ol style="list-style-type: none"> <li>1. The multimeter impedance is too low; below 10 MΩ/DCV.</li> <li>2. Cranking speed is too low (battery under-charged).</li> <li>3. The sampling timing of the tester and measured pulse were not synchronized (system is normal if measured voltage is over the standard voltage at least once).</li> <li>4. Faulty ECM (in case when above No. 1 – 3 are normal).</li> </ol>
	Initial and peak voltage are normal, but does not spark.	<ol style="list-style-type: none"> <li>1. Faulty spark plug or leaking ignition coil secondary current ampere.</li> <li>2. Faulty ignition coil.</li> </ol>
Ignition pulse generator	Peak voltage is lower than standard value.	<ol style="list-style-type: none"> <li>1. The multimeter impedance is too low; below 10 MΩ/DCV.</li> <li>2. Cranking speed is too low (battery under charged).</li> <li>3. The sampling timing of the tester and measured pulse were not synchronized (system is normal if measured voltage is over the standard voltage at least once).</li> <li>4. Faulty ECM (in case when above No. 1 – 3 are normal).</li> </ol>
	No peak voltage.	<ol style="list-style-type: none"> <li>1. Faulty peak voltage adapter.</li> <li>2. Faulty ignition pulse generator.</li> </ol>

## IGNITION SYSTEM INSPECTION

If no spark jumps at the plug, check all connections for loose or poor contact before measuring each peak voltage.

Use the recommended digital multimeter or commercially available digital multimeter with an impedance of 10 M $\Omega$ /DCV minimum.

The display value differs depending upon the internal impedance of the multimeter.

Connect the peak voltage adapter to the digital multimeter.

### TOOLS:

Peak voltage tester (U.S.A. only) or  
 Peak voltage adapter 07HGJ-0020100  
 with Commercially available digital multimeter  
 (impedance 10 M $\Omega$ /DCV minimum)

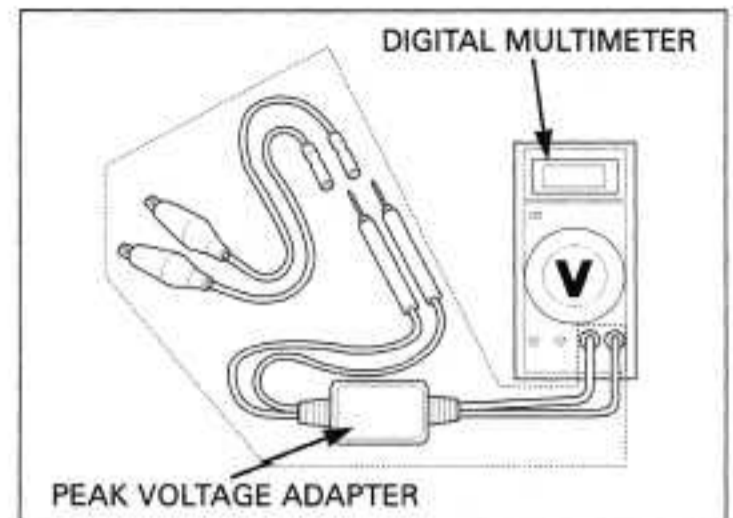

## IGNITION COIL PRIMARY PEAK VOLTAGE

Remove the spark plug cover (page 3-6).

Check all system connections before inspection. If the system is disconnected, incorrect peak voltage might be measured.

Check cylinder compression and check that the spark plugs are installed correctly in the cylinder.

Disconnect the spark plug caps from the spark plugs. Connect known-good spark plugs to the spark plug caps and ground the spark plugs to the cylinder as done in a spark test.

With the ignition coil primary wire connected, connect the peak voltage adapter to the ignition coil.

### CONNECTION:

Front: Blue/yellow (+) - body ground (-)

Rear: Yellow/blue(+) - body ground (-)

Turn the ignition switch to "ON" and engine stop switch to "O".

Check for initial voltage at this time.

The battery voltage should be measured.

If the initial voltage cannot be measured, check the power supply circuit (refer to the troubleshooting, page 17-2).

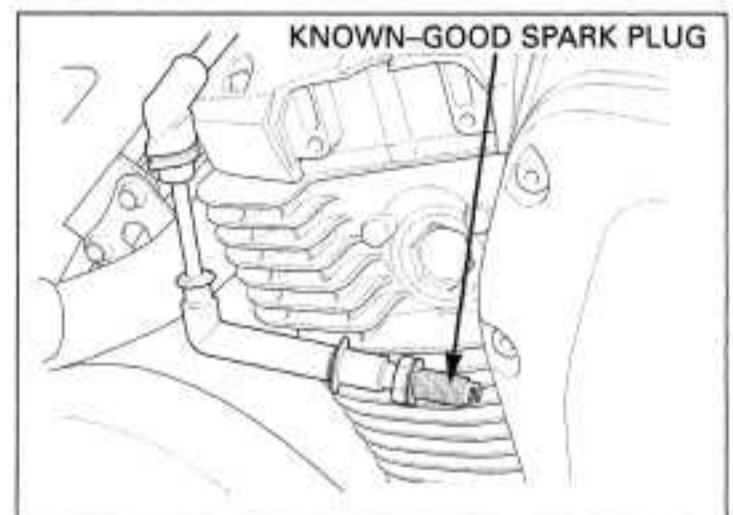

## IGNITION SYSTEM

Avoid touching the spark plug and tester probes to prevent electric shock.  
Crank the engine with the starter motor and read the ignition coil primary peak voltage.

**PEAK VOLTAGE: 100 V minimum**

If the peak voltage is abnormal, check for an open circuit or poor connection in the Black/white wires.  
If no defects are found in the harness, refer to the troubleshooting chart on page 17-2.

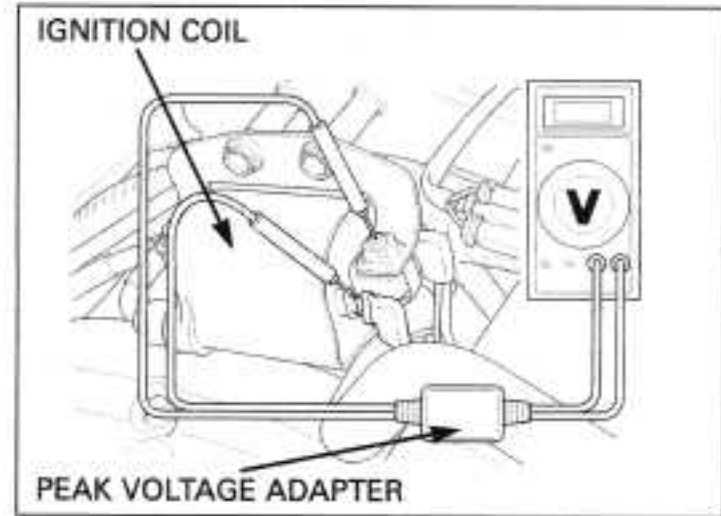

### IGNITION PULSE GENERATOR PEAK VOLTAGE

Check cylinder compression and check that the spark plugs are installed correctly.

Remove the seat (page 2-2).

Disconnect the ECM 22P gray connector.  
Connect the peak voltage adapter probes to the connector terminals of the wire harness side.

#### TOOLS:

Peak voltage tester (U.S.A. only) or  
Peak voltage adapter 07HGJ-0020100  
with Commercially available digital multimeter  
(impedance 10 M $\Omega$ /DCV minimum) or Peak voltage  
tester

**CONNECTION: White/yellow (+) - Yellow (-)**

Retract the side stand.  
Turn the ignition switch to "ON" and engine stop switch to "O".  
Avoid touching the tester probes to prevent electric shock.  
Crank the engine with the starter motor and read ignition pulse generator peak voltage.

**PEAK VOLTAGE: 0.7 V minimum**

If the peak voltage measured is abnormal, recheck the following:

Disconnect the ignition pulse generator 2P connector.  
Connect the peak voltage adapter to the terminals of the ignition pulse generator side and recheck the peak voltage.

If the peak voltage at the ECM 22P gray connector is abnormal and peak voltage at the ignition pulse generator 2P connector is normal, check for poorly connected connectors or a broken wire harness.

If the peak voltage is abnormal at both connectors, follow the checks described in the troubleshooting on page 17-2.

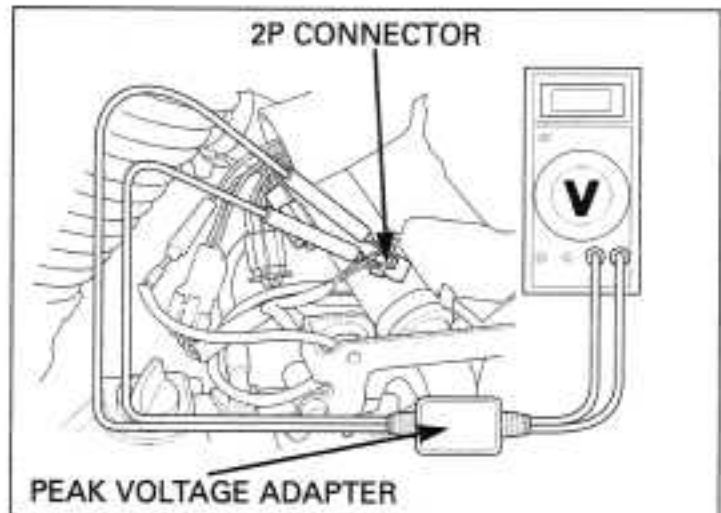
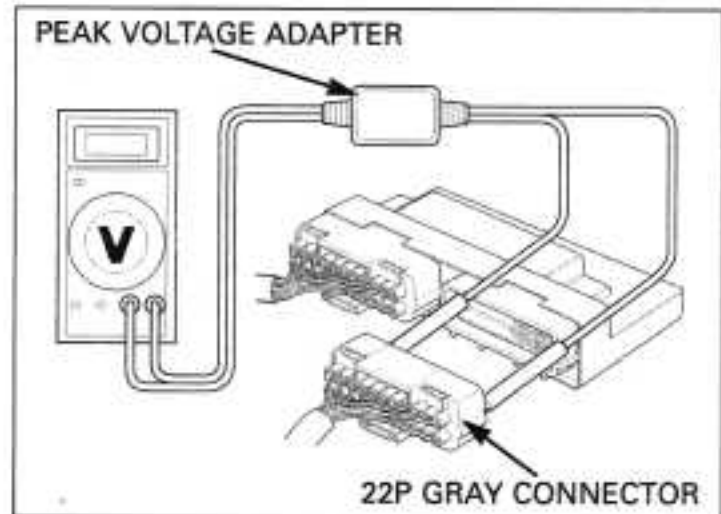



## IGNITION COIL

### FRONT IGNITION COIL

#### REMOVAL/INSTALLATION

Remove the fuel tank (page 5-56).  
Remove the spark plug caps from the spark plugs (page 3-6).

Remove the bolts, ground eyelet and front ignition coil.

Disconnect the ignition primary wires from the front ignition coil.

Installation is in the reverse order of removal.

*Route the spark plug wires and primary wires properly (page 1-23).*

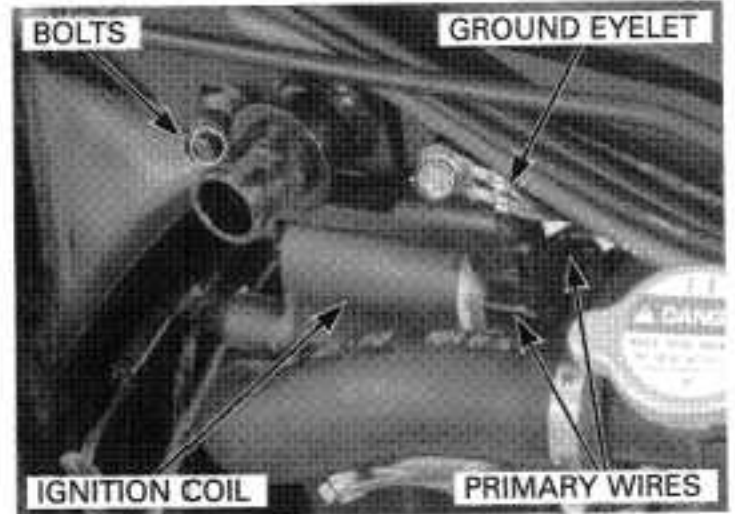

### REAR IGNITION COIL

#### REMOVAL/INSTALLATION

Remove the fuel tank (page 5-56).  
Remove the spark plug caps from the spark plugs (page 3-6).

Remove the bolts, collars and rear ignition coil.

Disconnect the ignition primary wires from the rear ignition coil.

Installation is in the reverse order of removal.

*Route the spark plug wires and primary wires properly (page 1-23).*

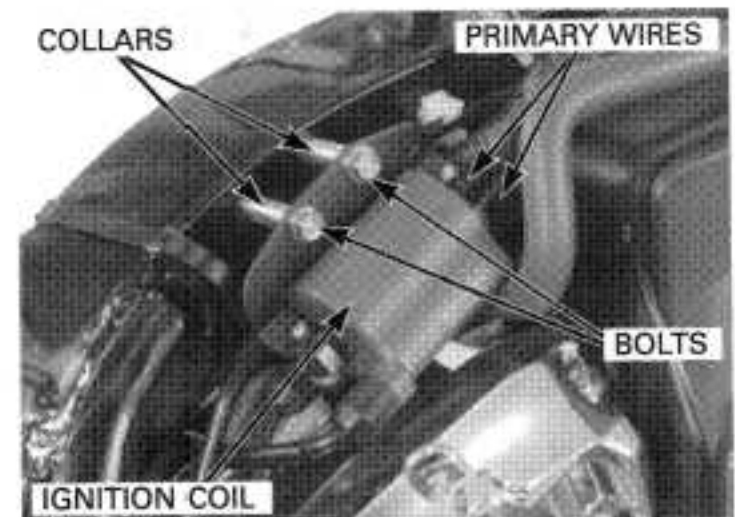

## IGNITION TIMING

The ignition timing is factory preset and only needs to be checked when an electrical system component is replaced.

Warm up the engine to normal operating temperature.  
Stop the engine.

Remove the socket bolts and timing cover.

Remove the crankshaft hole cap.

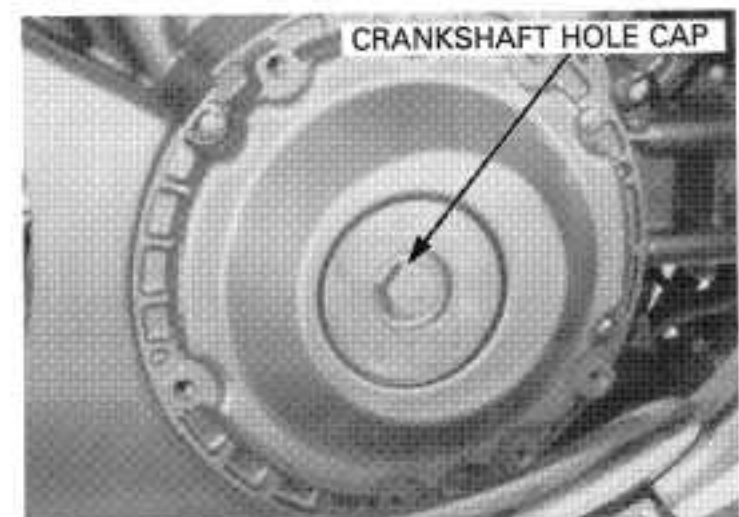
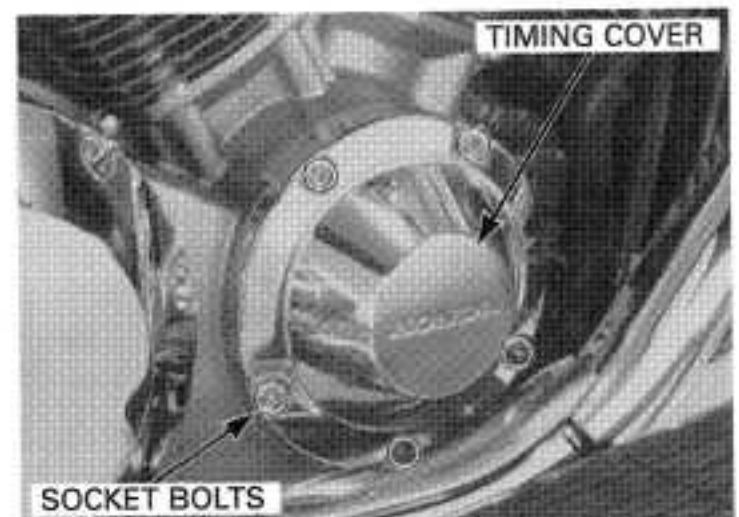



## IGNITION SYSTEM

Read the manufacturer's instructions for timing light operation.

Attach the timing light to the front (No.1) spark plug wire.

Start the engine and let it idle.

**IDLE SPEED: 800 ± 100 rpm**

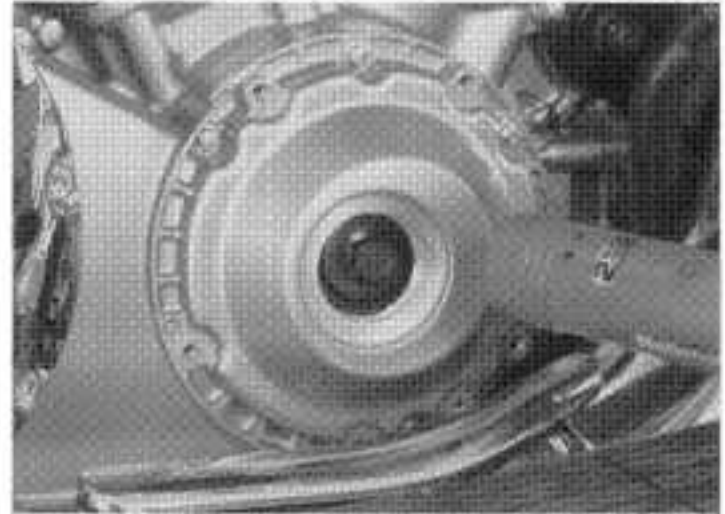

The timing is correct if the "F" mark aligns with the index notch on the crankcase cover.

Stop the engine and connect the timing light to the rear (No.2) spark plug wire.

Recheck the ignition timing at the rear cylinder.

If the ignition timing is incorrect, inspect the ECM and ignition pulse generator.

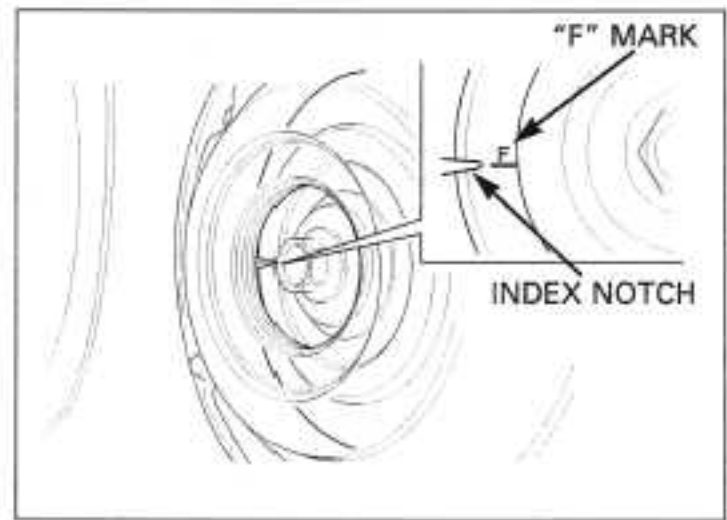

Coat a new O-ring with engine oil and install it in the crankshaft hole cap groove. Apply grease to threads and seating surface of the crankshaft hole cap.

Install and tighten the crankshaft hole cap after checking the ignition timing.

**TORQUE: 18 N·m (1.8 kgf·m, 13 lbf·ft)**

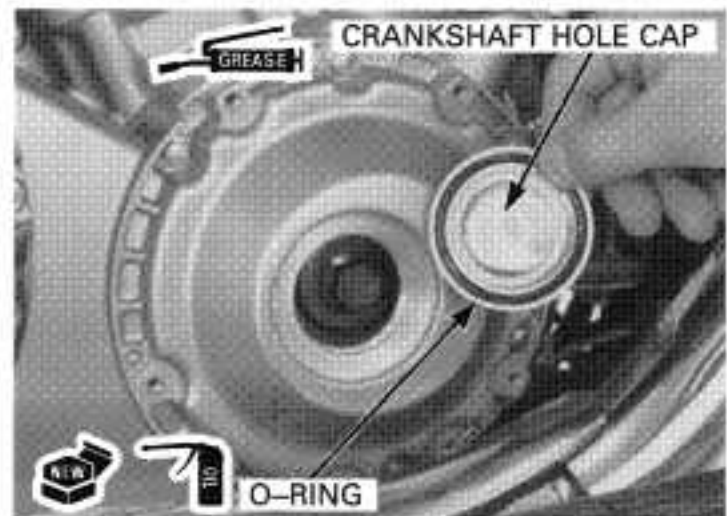

Install the timing cover and tighten the socket bolts securely.

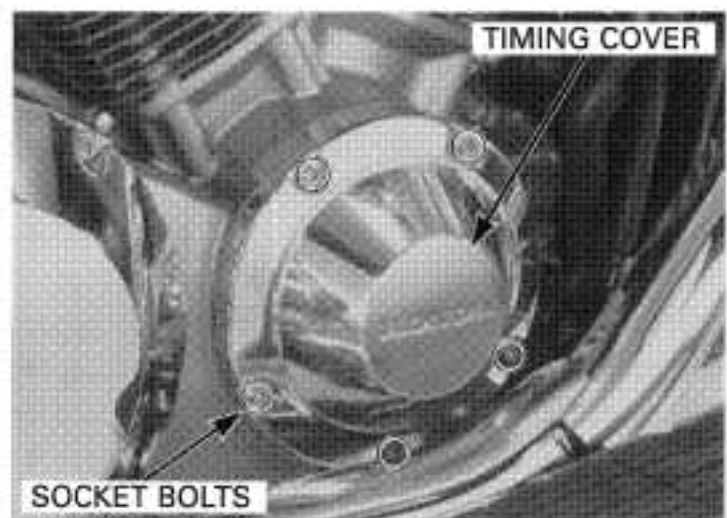

# ELECTRIC STARTER/STARTER CLUTCH

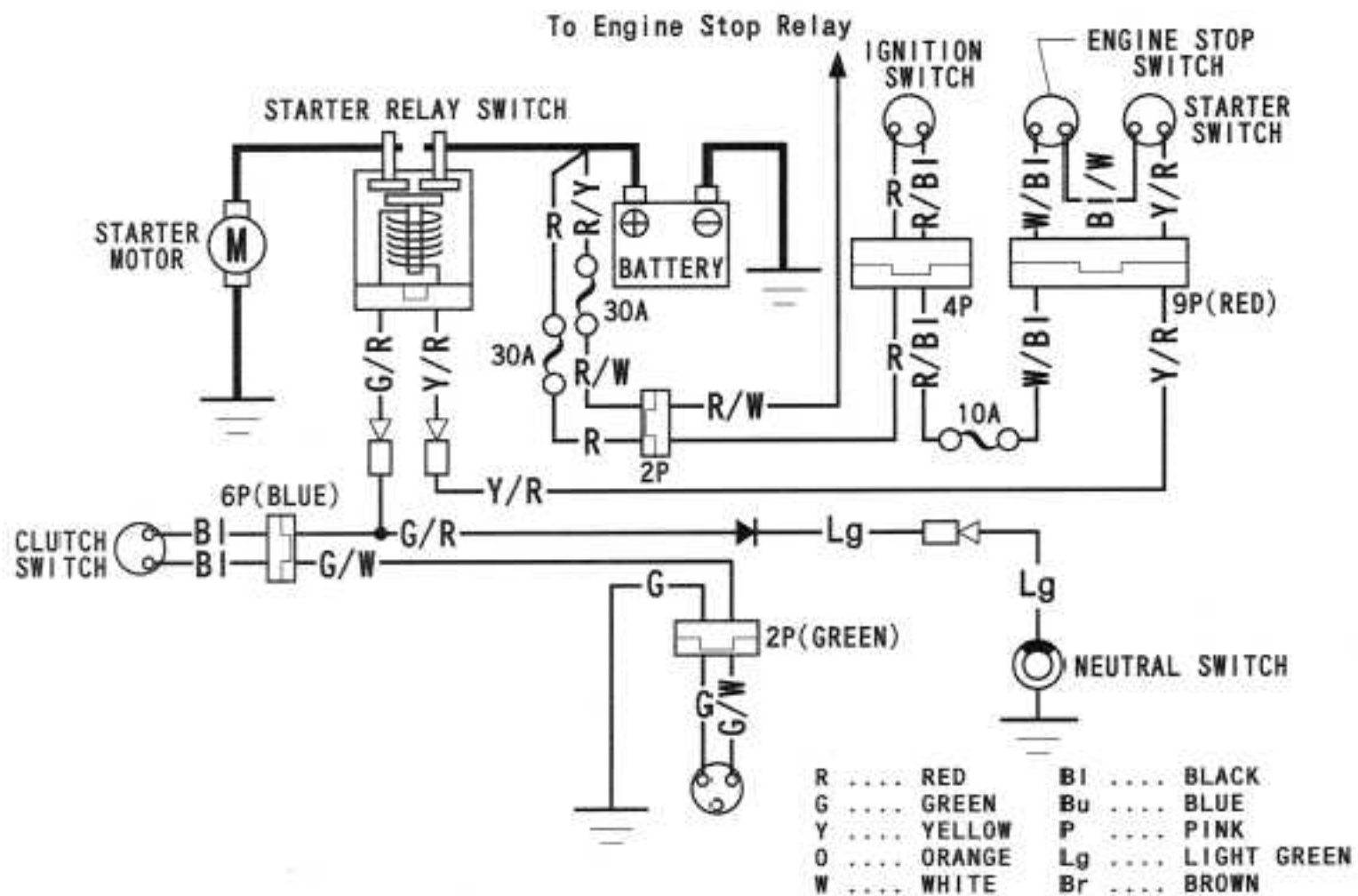
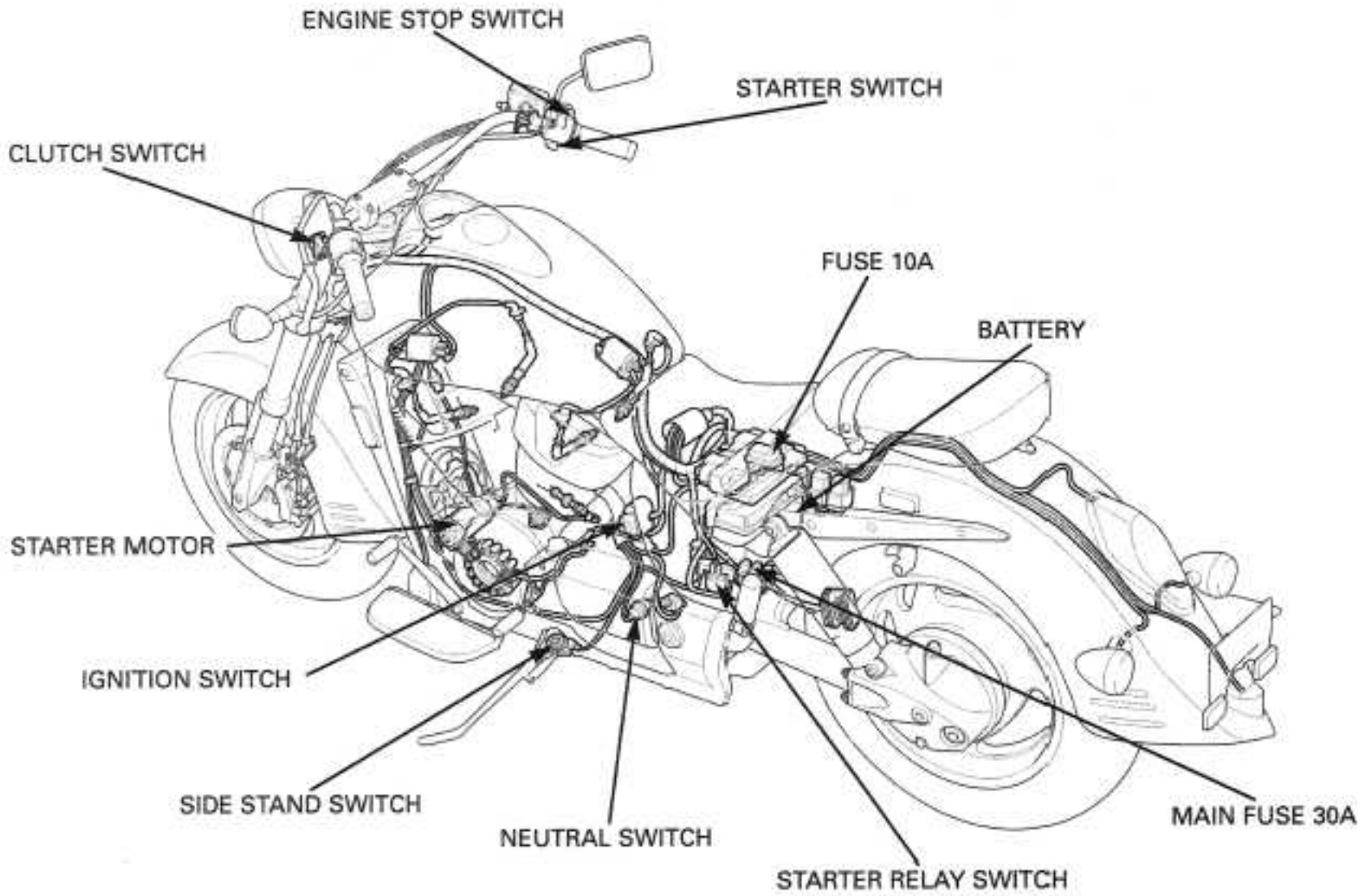

# 18. ELECTRIC STARTER/STARTER CLUTCH

<b>SERVICE INFORMATION</b>	<b>18-1</b>	<b>STARTER RELAY SWITCH</b>	<b>18-10</b>
<b>TROUBLESHOOTING</b>	<b>18-2</b>	<b>FLYWHEEL/STARTER CLUTCH</b>	<b>18-12</b>
<b>STARTER MOTOR</b>	<b>18-4</b>	<b>BALANCER WEIGHT</b>	<b>18-18</b>

## SERVICE INFORMATION

### GENERAL

- Always turn the ignition switch to "OFF" before servicing the starter motor. The motor could suddenly start, causing serious injury.
- The starter motor can be serviced with the engine in the frame.
- When checking the starter system, always follow the steps in the troubleshooting flow chart. (page 18-2).
- A weak battery may be unable to turn the starter motor quickly enough, or supply adequate ignition current.
- If the current is kept flowing through the starter motor while the engine is not cranking over, the starter motor may be damaged.
- For ignition switch, engine stop switch and clutch switch inspection, refer to Section 19.
- For side stand and neutral switch inspection, see Section 19.

### SPECIFICATION

Unit: mm (in)

ITEM		STANDARD	SERVICE LIMIT
Starter driven gear boss	O.D.	57.759 – 57.768 (2.2740 – 2.2743)	57.639 (2.2692)
	I.D.	44.000 – 44.016 (1.7323 – 1.7329)	44.10 (1.736)
Starter motor brush length		12.0 – 13.0 (0.47 – 0.51)	4.5 (0.18)

### TORQUE VALUES

Crankshaft hole cap	18 N•m (1.8 kgf•m, 13 lbf•ft)	Apply grease to the threads.
Flywheel bolt	137 N•m (14.0 kgf•m, 101 lbf•ft)	Apply oil to the threads and flange surface.
Starter clutch outer bolt	29 N•m (3.0 kgf•m, 22 lbf•ft)	Apply a locking agent to the threads.
Starter motor cable terminal nut	7 N•m (0.7 kgf•m, 5.1 lbf•ft)	
Starter motor case bolt	5 N•m (0.5 kgf•m, 3.6 lbf•ft)	
Balancer weight bolt	98 N•m (10.0 kgf•m, 72 lbf•ft)	

### TOOLS

Gear holder	07724-0010100 not available in U.S.A.
Flywheel holder	07725-0040000
Rotor puller	07733-0020001 or 07933-3290001
Remover weight	07936-371020A or 07936-3710200
Attachment, 24 x 26 mm	07746-0010700
Pilot, 10 mm	07746-0040100
Driver	07749-0010000
Remover shaft	07936-GE00100 or equivalent commercially available in U.S.A.
Remover head	07936-GE00200 or equivalent commercially available in U.S.A.
Torque limiter inspection tool A	07YMJ-MCF0100 not available in U.S.A.
Torque limiter inspection tool B	07YMJ-MCF0200 not available in U.S.A.

## ELECTRIC STARTER/STARTER CLUTCH

### TROUBLESHOOTING

- Check for the following before troubleshooting:
  - Blown main fuse (30 A) and sub fuse (10 A)
  - Loose battery and starter motor cable
  - Discharged battery
- With the ignition switch turned to "ON" and the engine stop switch to "○", the starter motor can be operated in either of the following conditions.
  - Transmission is in neutral
  - Transmission is in any gear except neutral, the clutch lever is squeezed, and the side stand is retracted

#### Starter motor will not turn

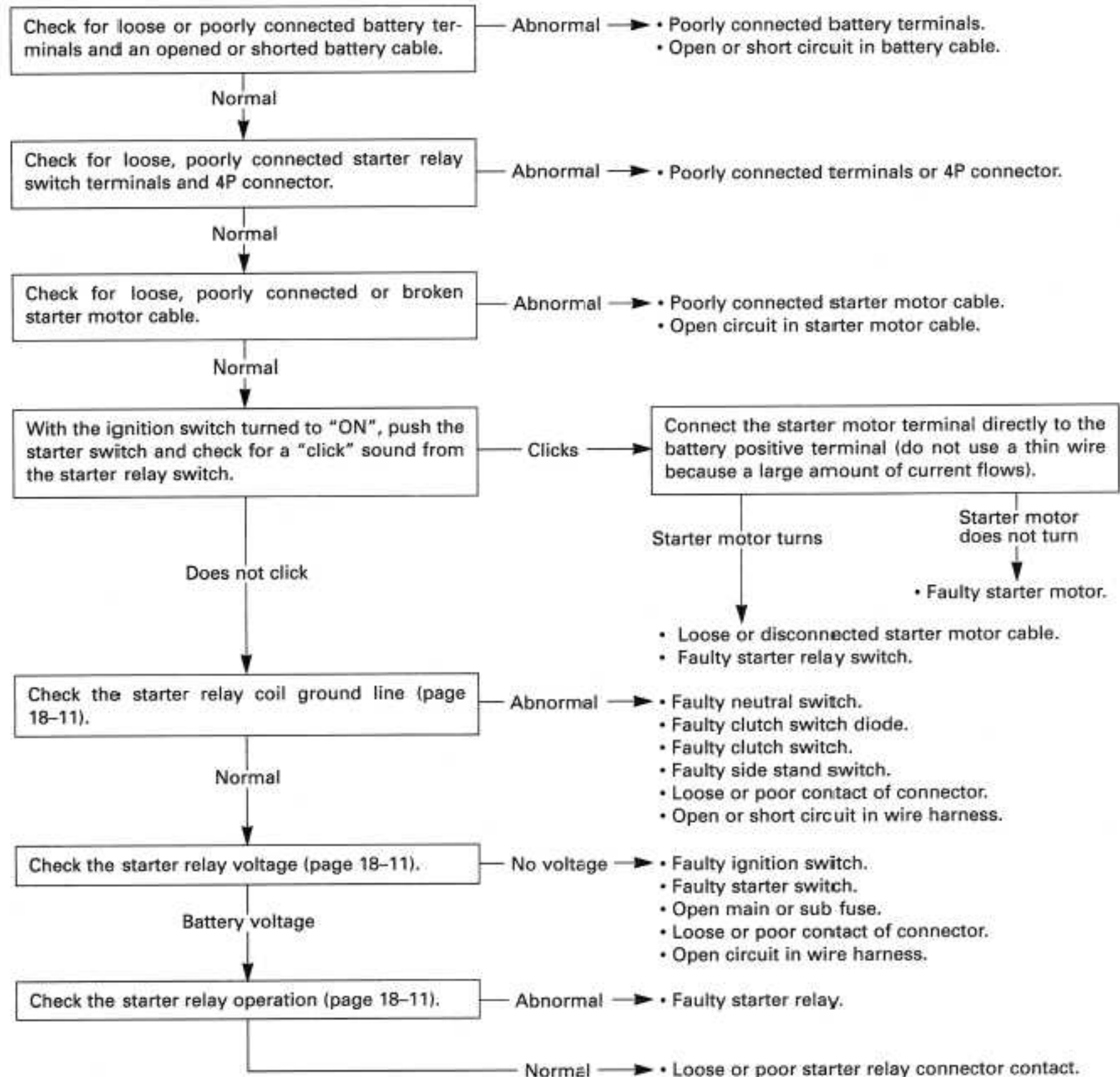

**Starter motor turns when the transmission is in neutral, but does not turn with the transmission in any position except neutral, with the side stand up and the clutch lever pulled in.**

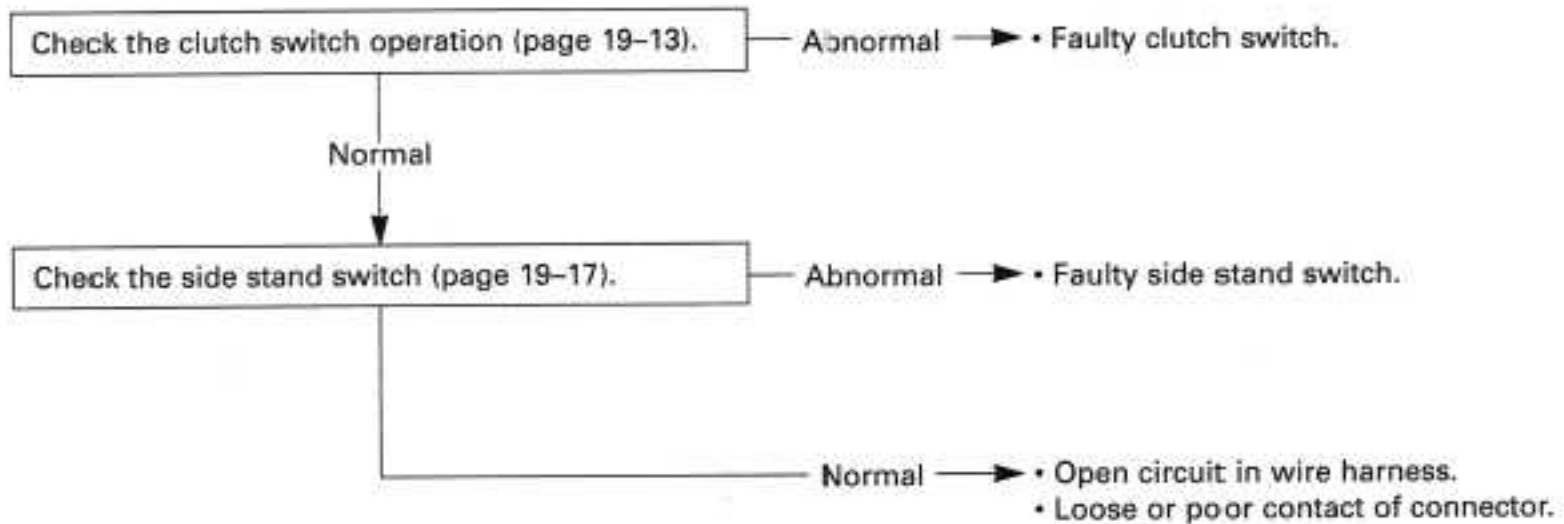

### **Starter motor turns slowly**

- Low specific gravity in battery (or dead battery)
- Poorly connected battery terminal cable
- Poorly connected starter motor cable
- Faulty starter motor
- Poorly connected battery ground cable

### **Starter motor turns, but engine does not turn**

- Faulty starter clutch
- Damaged or faulty starter motor gears

### **Starter relay switch "clicks", but engine does not turn over**

- Crankshaft does not turn due to engine problems
- Excessive starter motor gear friction



**STARTER MOTOR**

**REMOVAL**

*With the ignition switch turned to "OFF", remove the negative cable at the battery before servicing the starter motor.*

Remove the starter drive gear (page 18-12).

Release the rubber cap and remove the terminal nut to disconnect the starter motor cable.



Remove the bolts and starter motor.

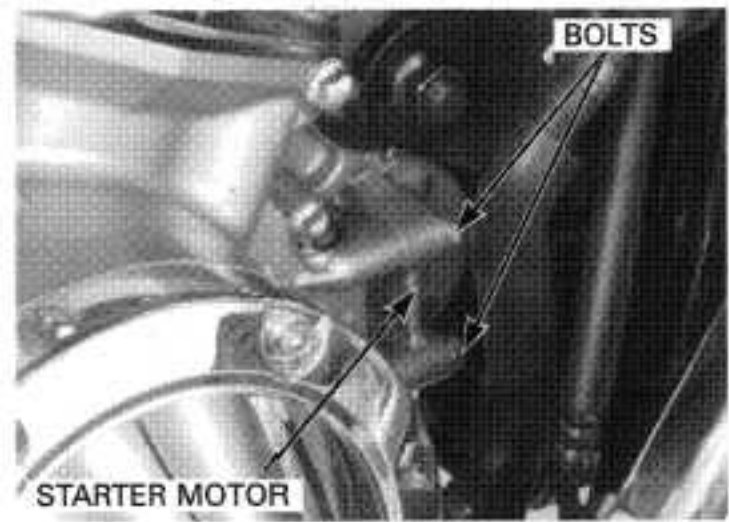

Remove the O-ring from the starter motor.

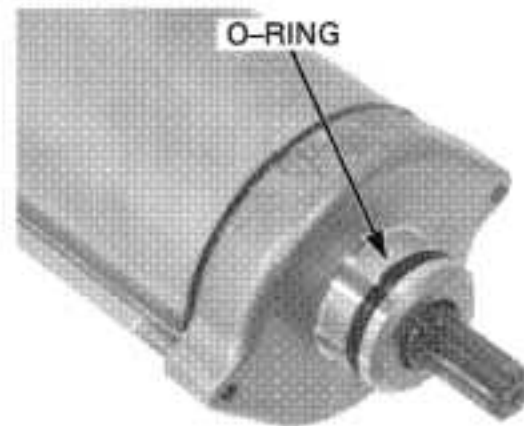

**DISASSEMBLY**

Remove the starter motor case bolts and rear cover.

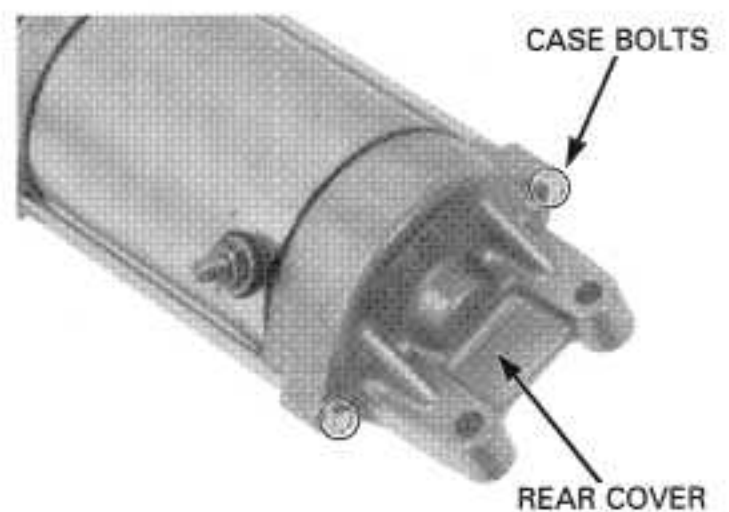

Record the location and number of shims.

Remove the following:

- Shims
- Seal ring

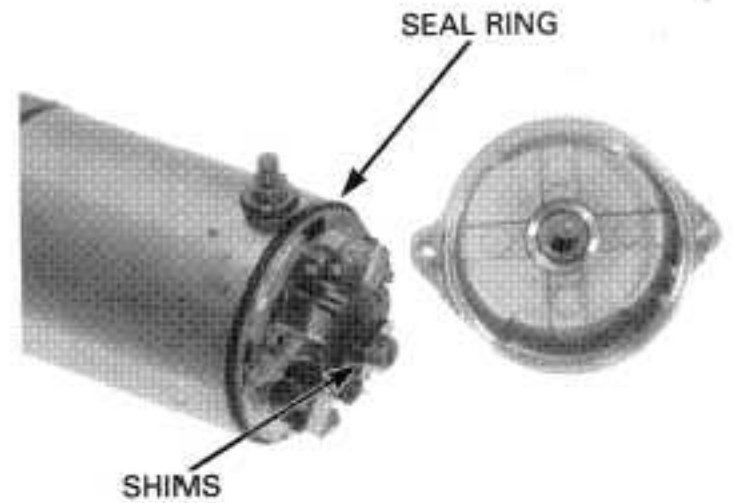

- Front cover
- Seal ring
- Lock washer
- Insulated washer
- Shims
- Armature

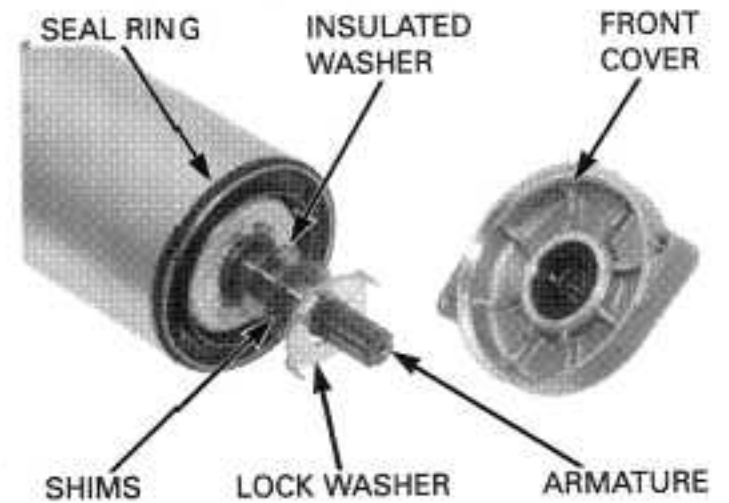

## INSPECTION

Check for continuity between the cable terminal and the (+) brushes. There should be continuity.

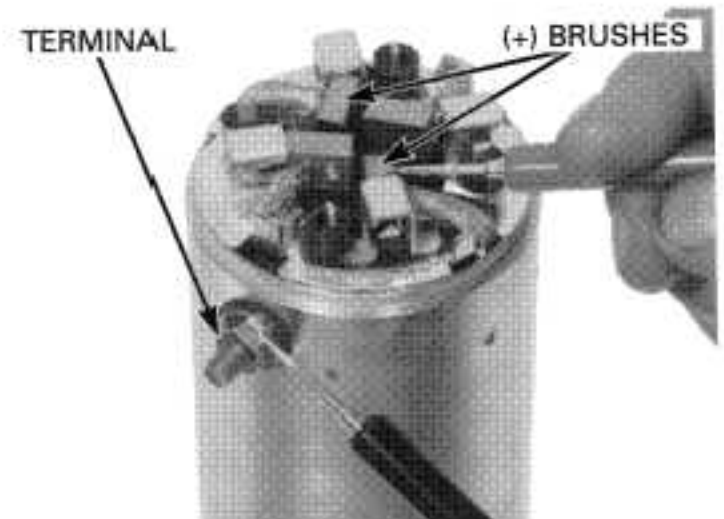

Check for continuity between the motor case and the cable terminal. There should be no continuity.

Check for continuity between the (+) and (-) terminals of the holder. There should be no continuity.

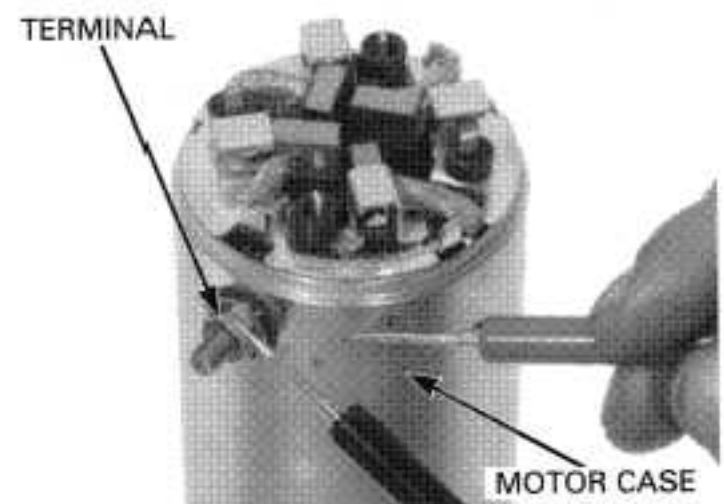

## ELECTRIC STARTER/STARTER CLUTCH

---

Inspect the brushes for damage and measure the brush length.

**SERVICE LIMIT: 4.5 mm (0.18 in)**

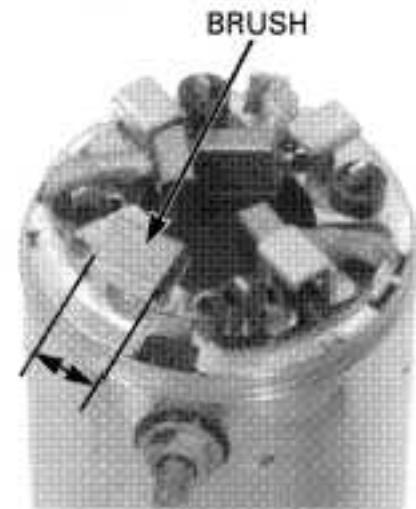

Check the bushing of the rear cover for wear or damage.

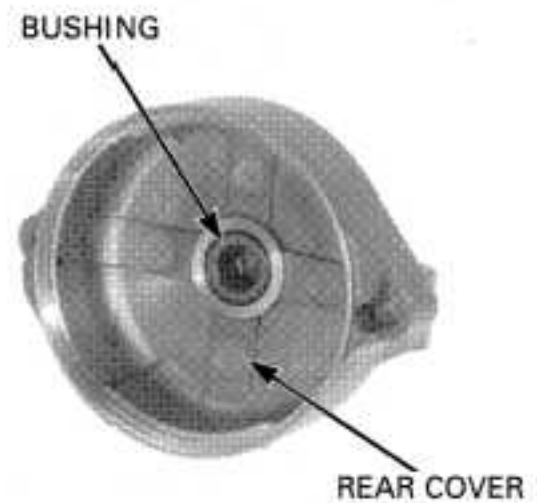

Check the front cover oil seal for fatigue or damage. Check the needle bearing for damage.

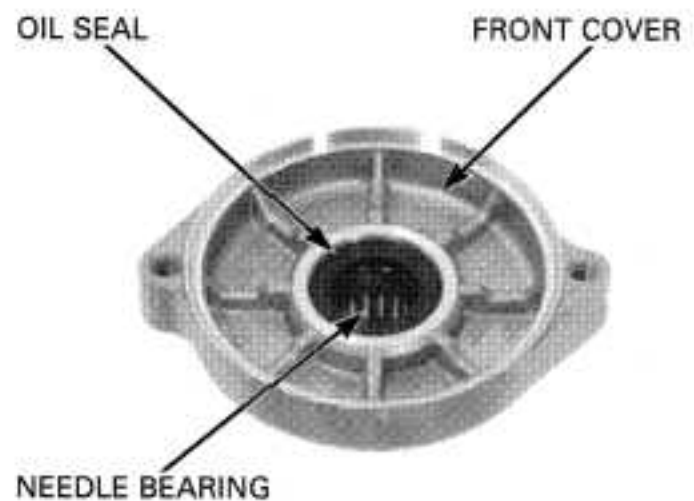

*Do not use emery or sandpaper on the commutator.*

Inspect the commutator bars for discoloration. Bars that are discolored in pairs indicate grounded armature coils, in which case the starter motor must be replaced.

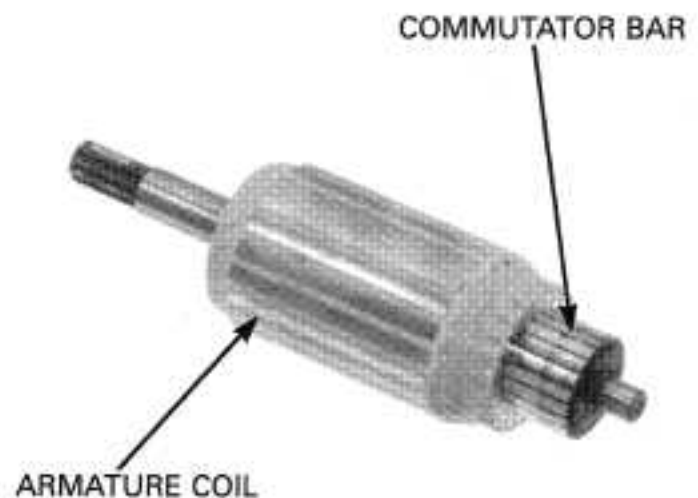

Check for continuity between individual commutator bars; there should be continuity.

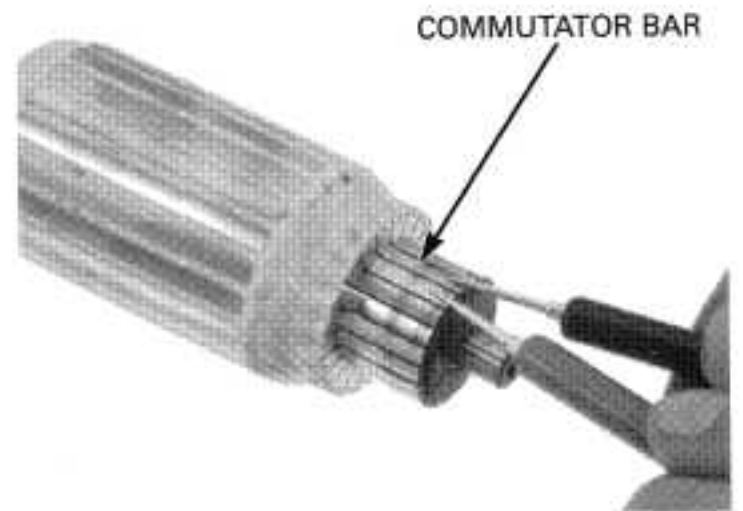

Also, check for continuity between individual commutator bars and the armature shaft; there should be no continuity.

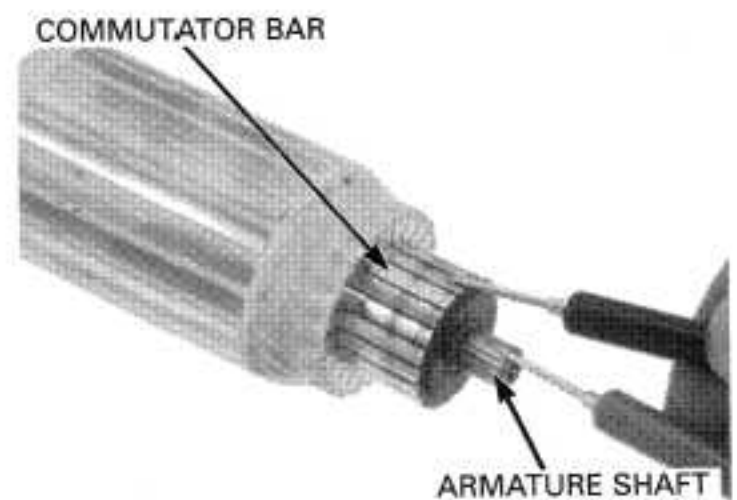

Remove the following:

- Nut
- Washer
- Insulators
- O-ring

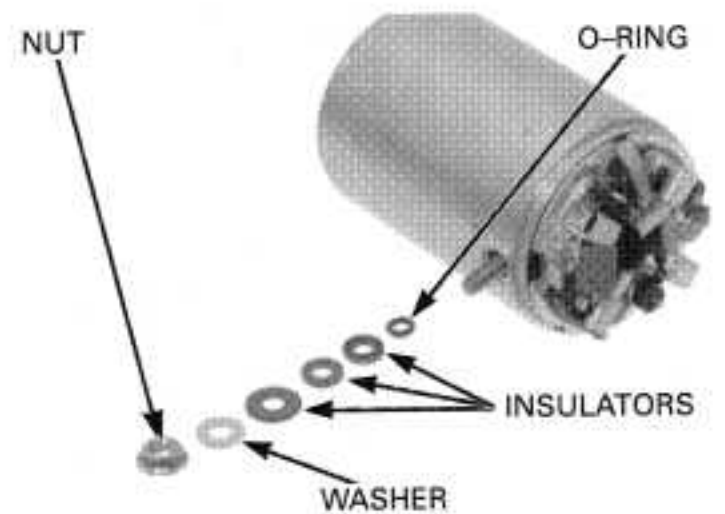

- Brush holder assembly
- Brush/terminal
- Collar

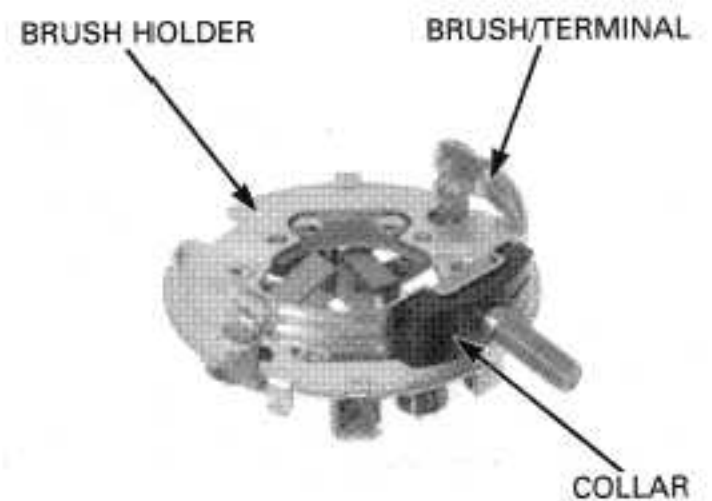

# ELECTRIC STARTER/STARTER CLUTCH

## ASSEMBLY

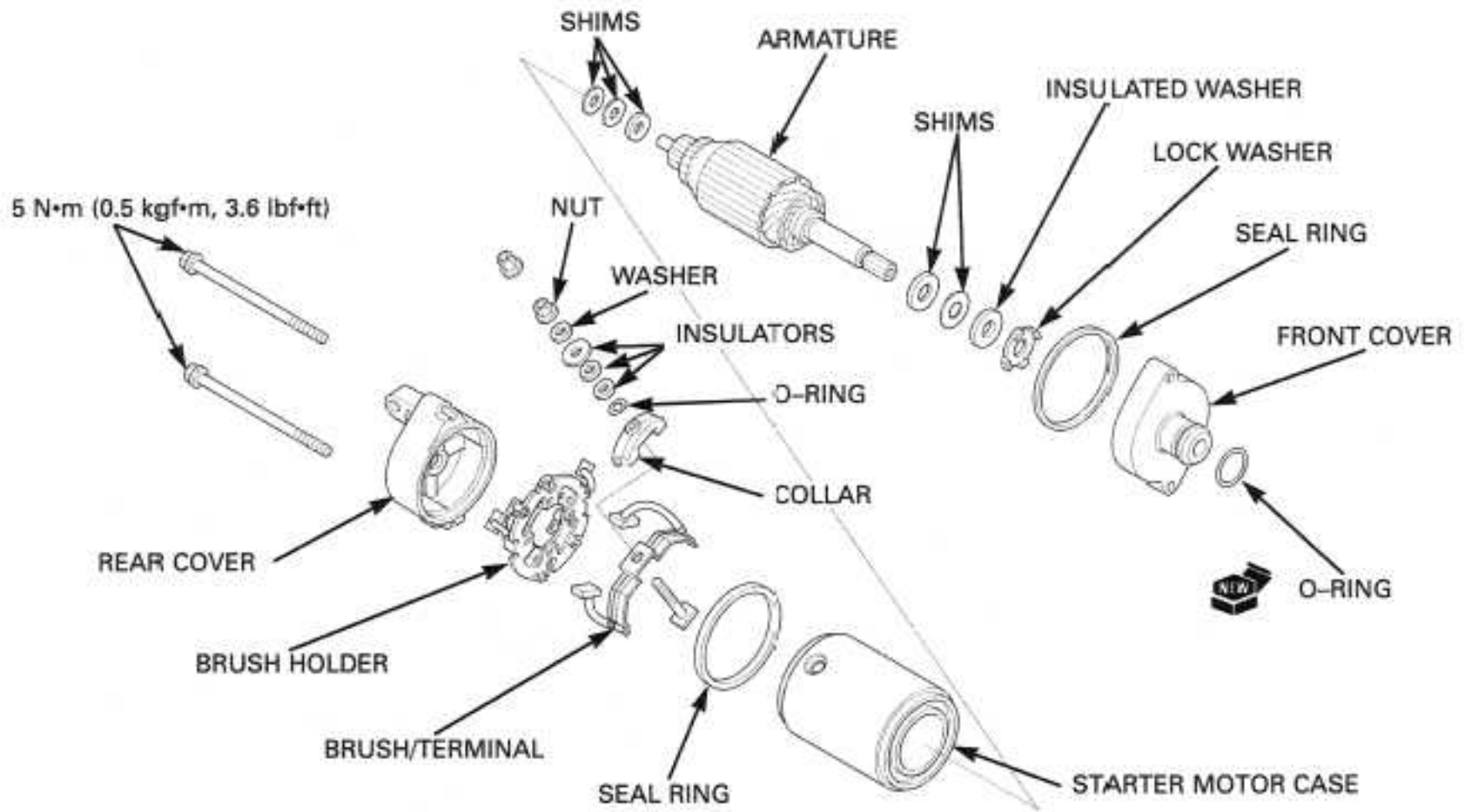

Align the terminal holder boss with the groove in the motor case.

Set the collar on the brush/terminal.  
Set the brush/terminal on the brush holder.  
Install the brush holder onto the motor case.

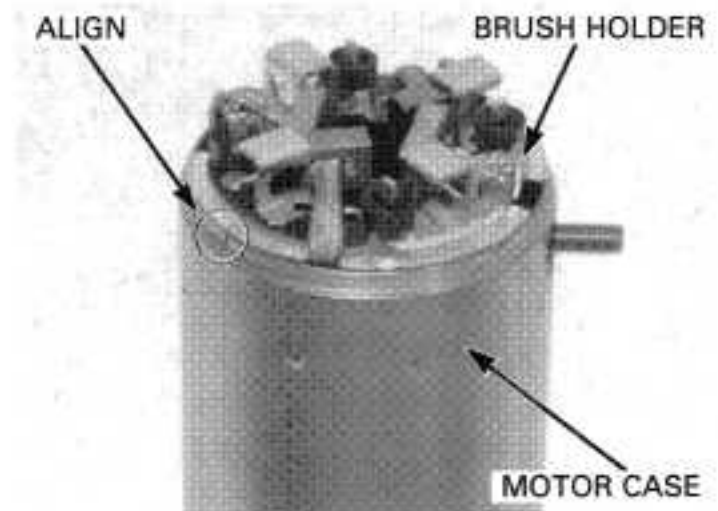

Install the insulators properly as noted during removal.

Install the following:  
— O-ring  
— Insulators  
— Washer  
— Nut

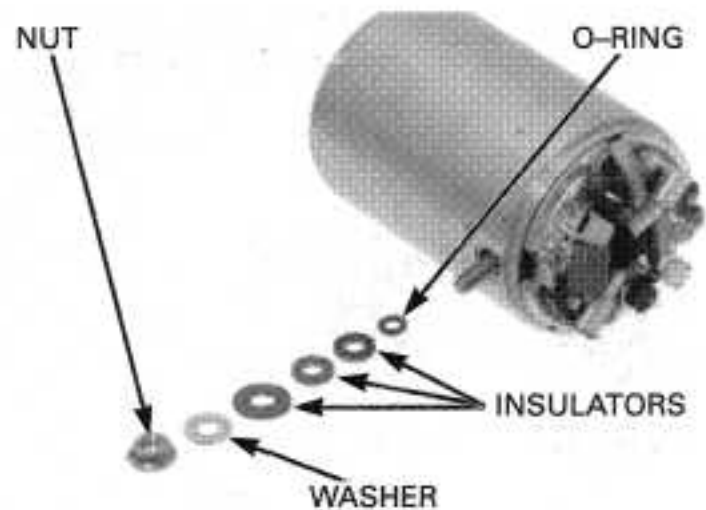



## ELECTRIC STARTER/STARTER CLUTCH

*The coil may be damaged if the magnet pulls the armature against the case.*

Install the armature in the motor case.

*Install the shims properly as noted during removal.*

Install the shims on the armature shaft.

*When installing the cover, take care to prevent damaging the oil seal lip with the shaft.*

Install the insulated washer and lock washer on the armature shaft.

Apply grease to the oil seal lips and bearing, and install the front cover by aligning its lugs with the lock washer tab.

*Install the shims properly as noted during removal.*

Install the seal ring onto the motor case.  
Install the shims on the armature shaft.

Assemble the motor case and rear cover, aligning the brush holder boss with the groove in the rear cover.

Align the index lines on the front cover and motor case.

Install and tighten the starter motor case bolt to the specified torque.

**TORQUE: 5 N·m (0.5 kgf·m, 3.6 lbf·ft)**

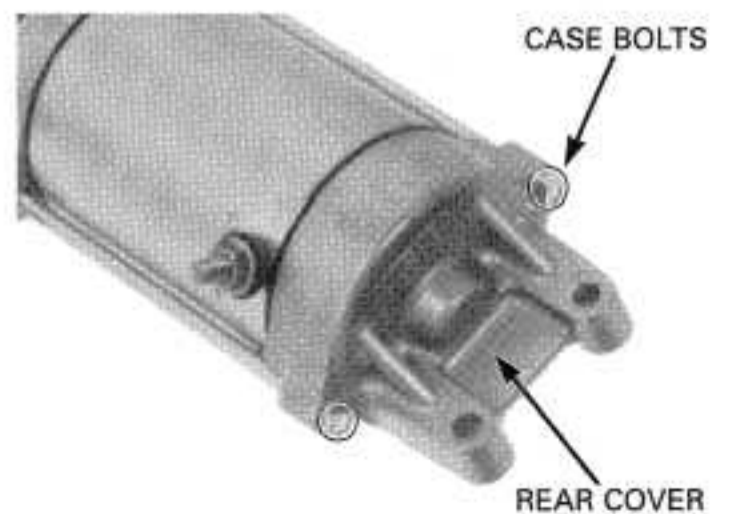
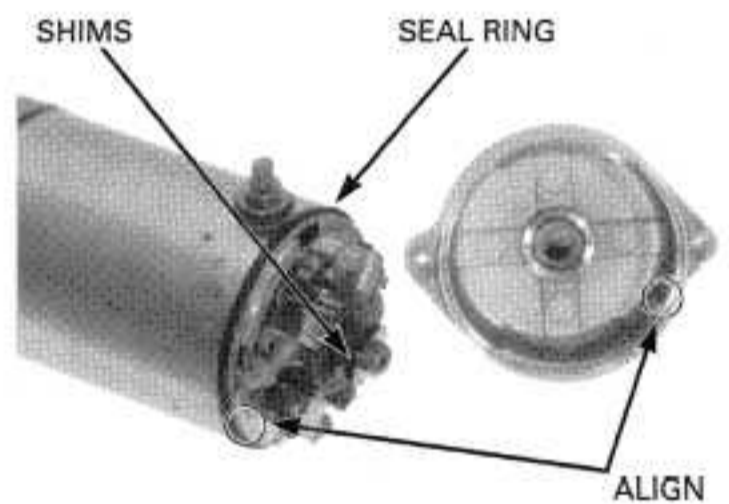
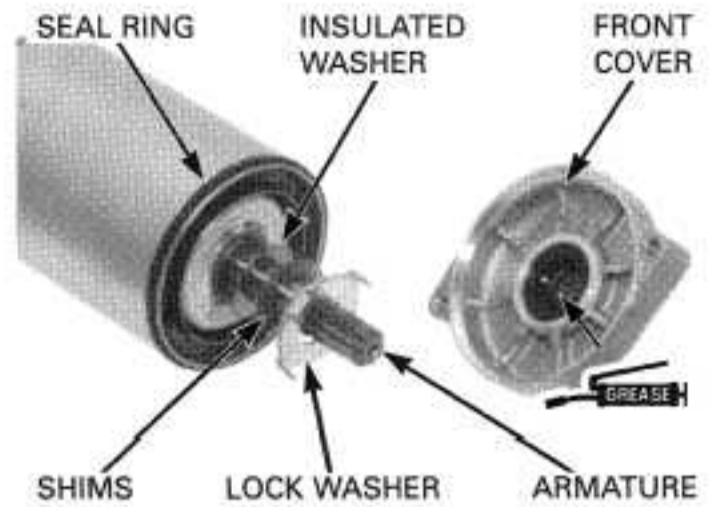

## ELECTRIC STARTER/STARTER CLUTCH

### INSTALLATION

Apply clean engine oil to the new O-ring.  
Install the O-ring to the groove on the starter motor.

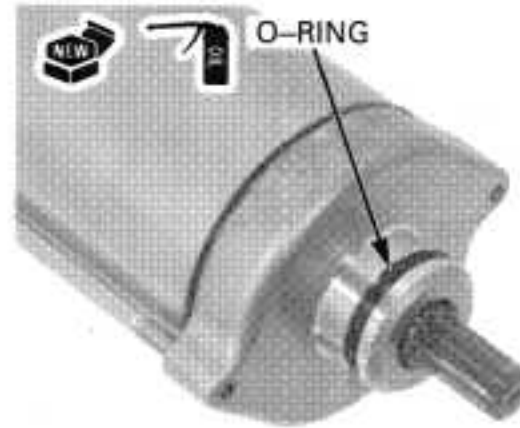

Install the starter motor into the crankcase.

Install and tighten the bolts securely.

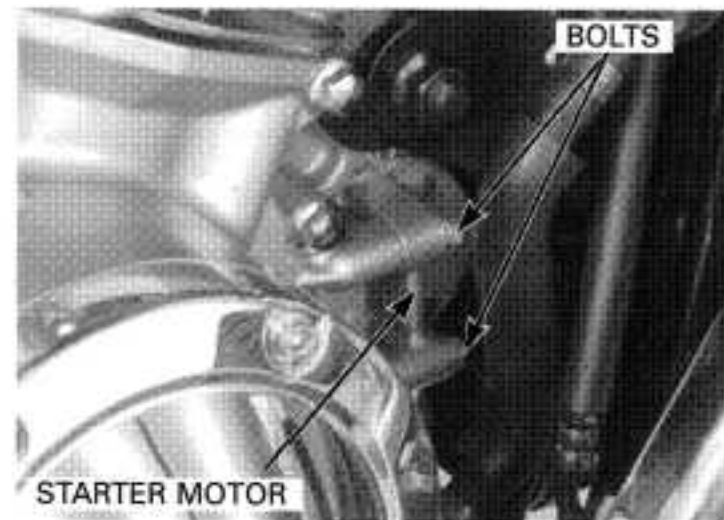

Route the starter motor cable and tighten the terminal nut to the specified torque.

**TORQUE: 7 N·m (0.7 kgf·m, 5.1 lbf·ft)**

Install the rubber cap over the motor terminal securely.

Install the starter drive gear (page 18-18).



## STARTER RELAY SWITCH

### INSPECTION

Remove the left side cover (page 2-2).

Shift the transmission into neutral.  
Turn the ignition switch to "ON" and engine stop switch to "O". Depress the starter switch button.

The coil is normal if the starter relay switch clicks.

If you do not hear the switch "click", inspect the relay switch using the procedure on the next page.

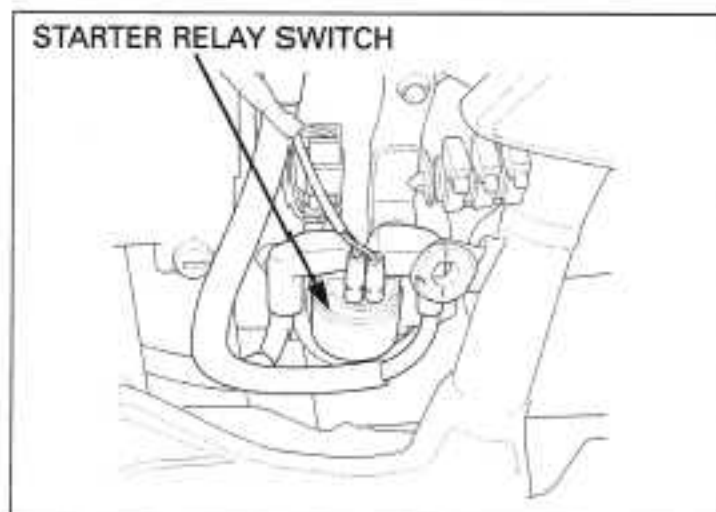

### GROUND LINE

Disconnect the starter relay switch connectors. Check for continuity between the Green/red wire and ground.

If there is continuity when the transmission is in neutral or when the clutch is disengaged and the side stand switch is up, the ground circuit is normal (in neutral, there is a slight resistance due to the diode).

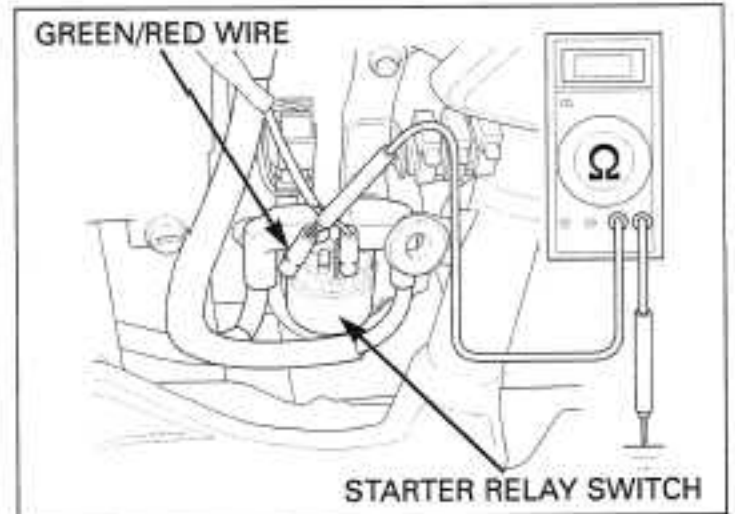

### STARTER RELAY VOLTAGE

Connect the starter relay switch connectors. Shift the transmission into neutral.

Measure the voltage between the Yellow/red wire (+) and ground.

There should be battery voltage only when the starter switch button is depressed with the ignition switch turned to "ON".

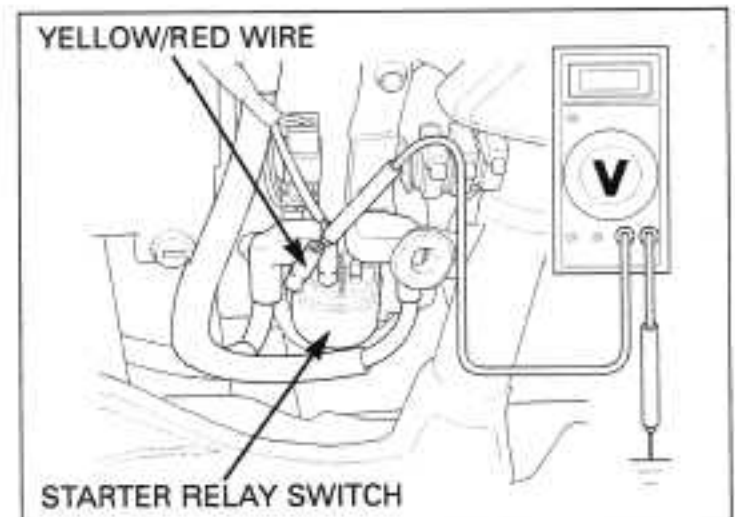

### OPERATION CHECK

Disconnect the starter relay switch connectors and cables.

Connect a fully charged 12-V battery positive (+) wire to the starter relay switch Yellow/red wire and negative (-) wire to the Green/red wire.

There should be continuity between the large switch terminals while the battery is connected, and no continuity when the battery is disconnected.

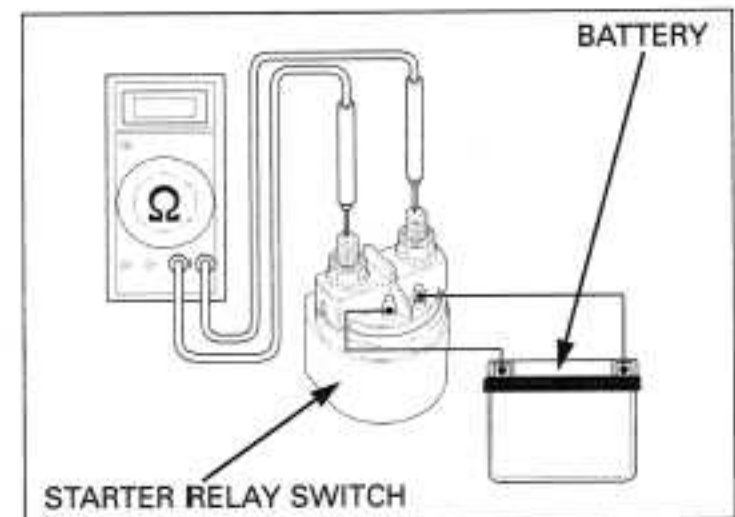

### REMOVAL/INSTALLATION

Remove the left side cover (page 2-2).

Disconnect the starter relay switch connectors. Remove the nuts and cables.

Remove the starter relay switch from the tabs on the battery case.

Installation is in the reverse order of removal.

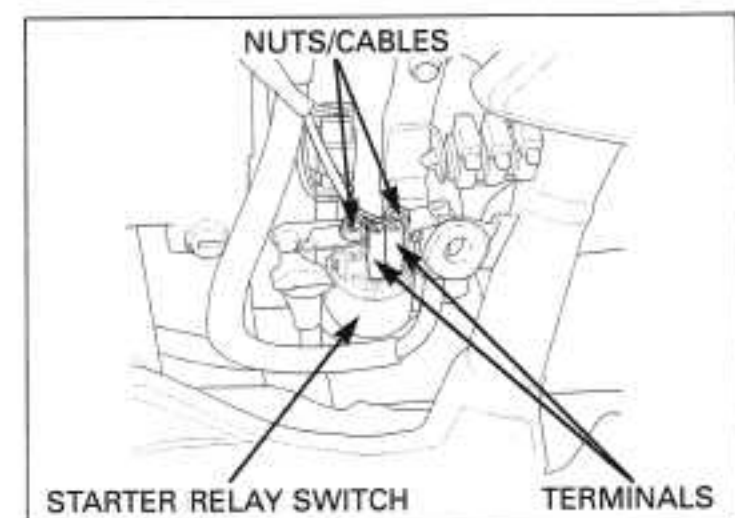

**FLYWHEEL/STARTER CLUTCH**

**STARTER DRIVEN GEAR/TORQUE LIMITER REMOVAL**

Remove the left crankcase cover (page 16-9).

Remove the shaft, starter drive gear and torque limiter.

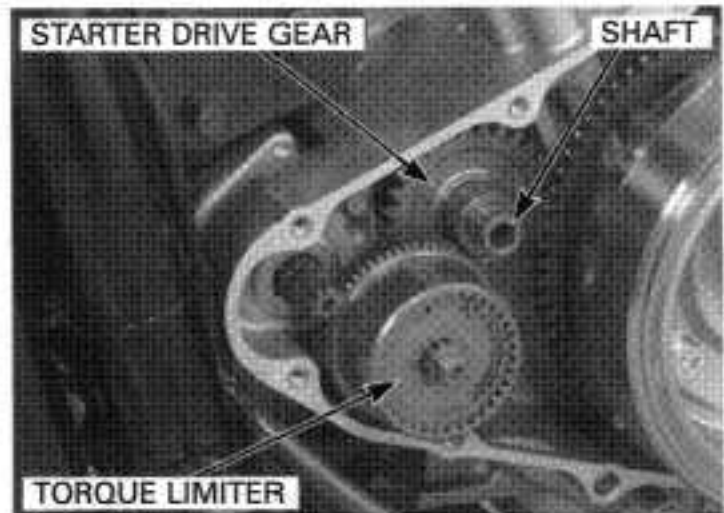

**LEFT CRANKCASE COVER BEARING REPLACEMENT**

Check the left crankcase cover bearing for damage or excessive play. Replace, if necessary.

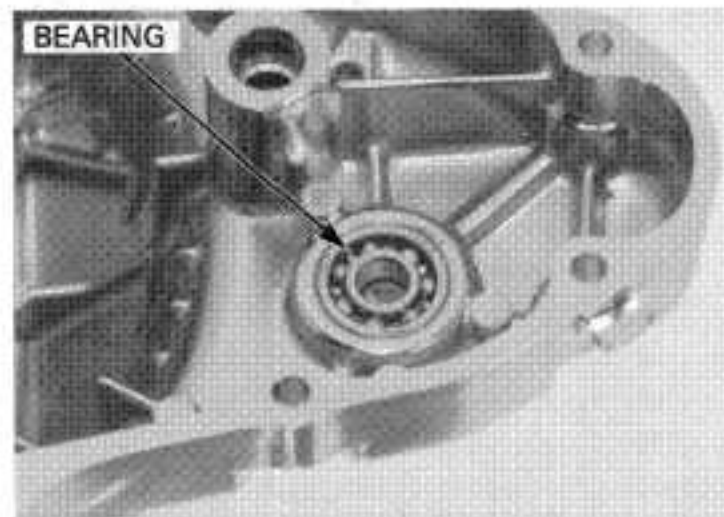

*Always wear insulated gloves when handling the left crankcase cover after it has been heated.*

Heat the left crankcase cover to 80 °C (176 °F) evenly using a heat gun. Remove the bearing with the following special tools.

- TOOL:**
- |                |  |
|----------------|--|
| Remover shaft  | 07936-GE00100 or equivalent commercially available in U.S.A. |
| Remover head   | 07936-GE00200 or equivalent commercially available in U.S.A. |
| Remover weight | 07936-371020A or 07936-3710200                               |

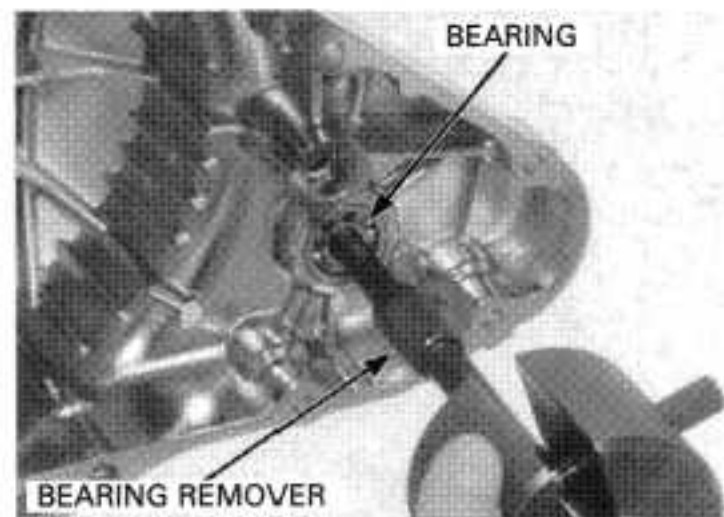

Drive in a new bearing using the special tools.

- TOOLS:**
- |                        |               |
|------------------------|---------------|
| Driver                 | 07749-0010000 |
| Attachment, 24 x 26 mm | 07746-0010700 |
| Pilot, 10 mm           | 07746-0040100 |

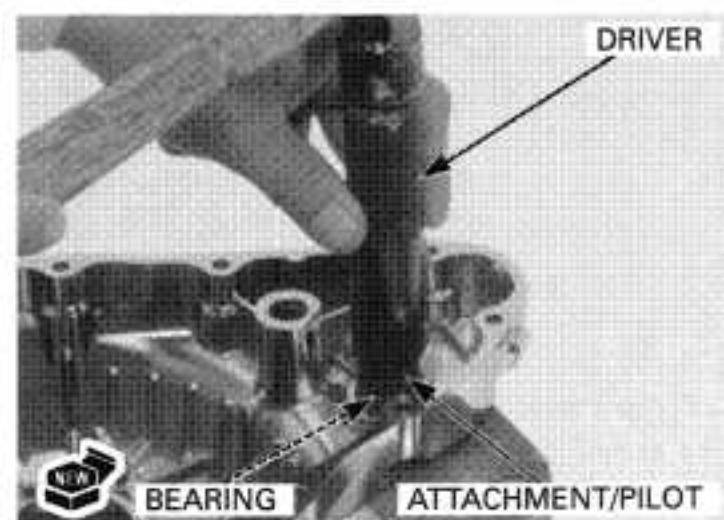



**LEFT CRANKCASE BEARING REPLACEMENT**

Check the left crankcase bearing for damage or excessive play. Replace, if necessary.

*Always wear insulated gloves when handling the left crankcase after it has been heated.*

Heat the left crankcase to 80 °C (176 °F) evenly using a heat gun. Remove the bearing with the following special tools.

- TOOL:**
- Remover shaft** 07936-GE00100 or equivalent commercially available in U.S.A.
  - Remover head** 07936-GE00200 or equivalent commercially available in U.S.A.
  - Remover weight** 07936-371020A or 07936-3710200

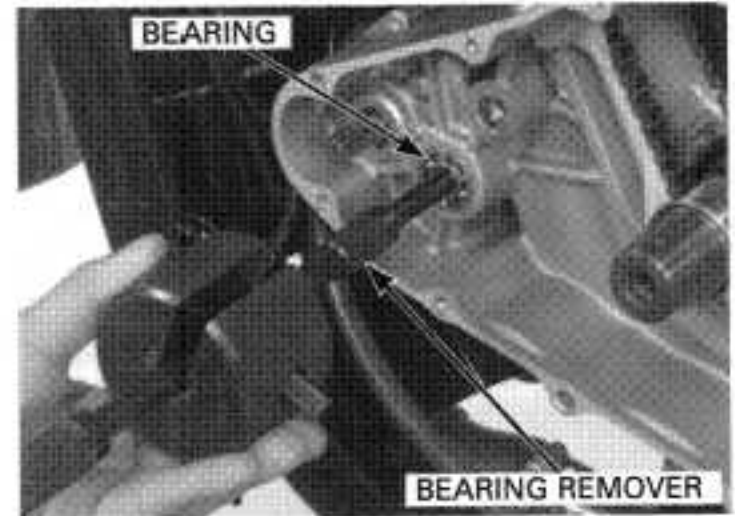
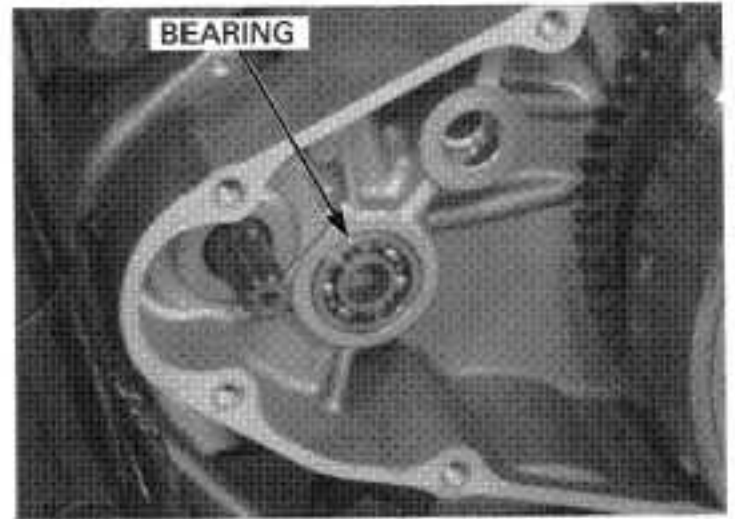

Drive in a new bearing using the special tools.

- TOOLS:**
- Driver** 07749-0010000
  - Attachment, 24 x 26 mm** 07746-0010700
  - Pilot, 10 mm** 07746-0040100

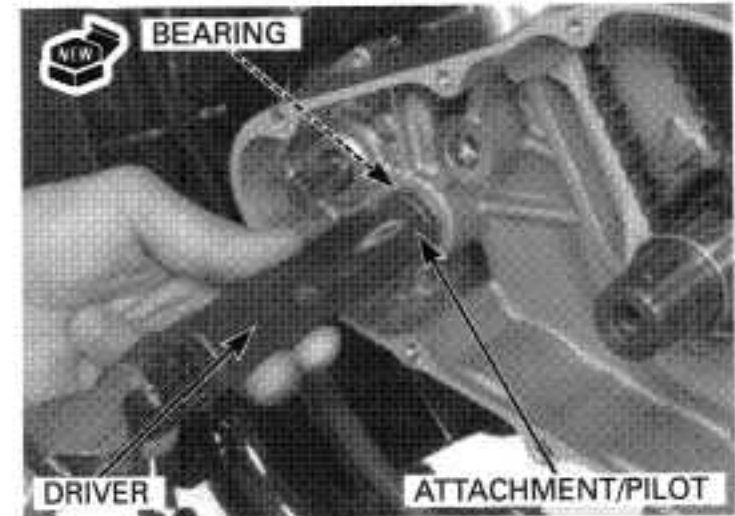

**STARTER DRIVE GEAR INSPECTION**

Check the starter drive gear for abnormal wear or damage.

Check the starter drive gear shaft for abnormal wear or damage.

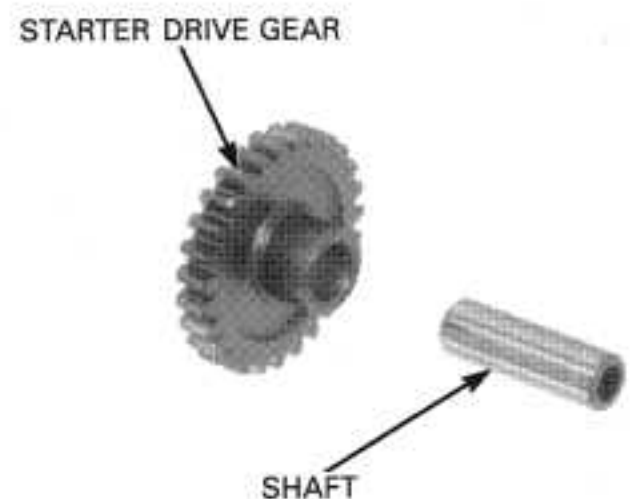



### STARTER TORQUE LIMITER INSPECTION

Check the starter torque limiter gear for abnormal wear or damage.

Hold the torque limiter in a vise with soft jaws or a shop towel to prevent damaging the gear teeth.

Check the torque limiter slip torque with the special tool and a torque wrench.

#### TOOL:

Torque limiter inspection tool A 07YMJ-MCF0100  
not available in U.S.A.

Torque limiter inspection tool B 07YMJ-MCF0200  
not available in U.S.A.

#### SLIP TORQUE:

52.9 – 84.3 N·m (5.4 – 8.6 kgf·m, 39 – 62 lbf·ft)

Replace the torque limiter assembly if the slip torque is out of specification.

TORQUE LIMITER

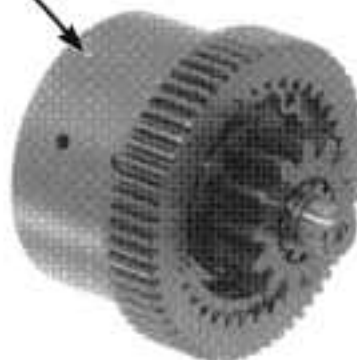

TORQUE LIMITER

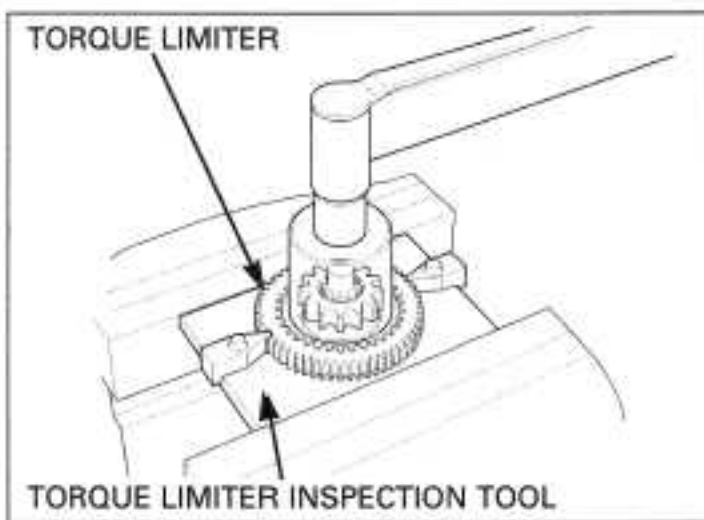

### FLYWHEEL REMOVAL

Remove the left crankcase cover (page 16-9).

Hold the flywheel using the flywheel holder, then remove the flywheel bolt.

#### TOOL:

Flywheel holder 07725-0040000

Remove the washer.

Remove the flywheel using the special tool.

#### TOOL:

Flywheel puller 07733-0020001 or  
07933-3290001

FLYWHEEL BOLT

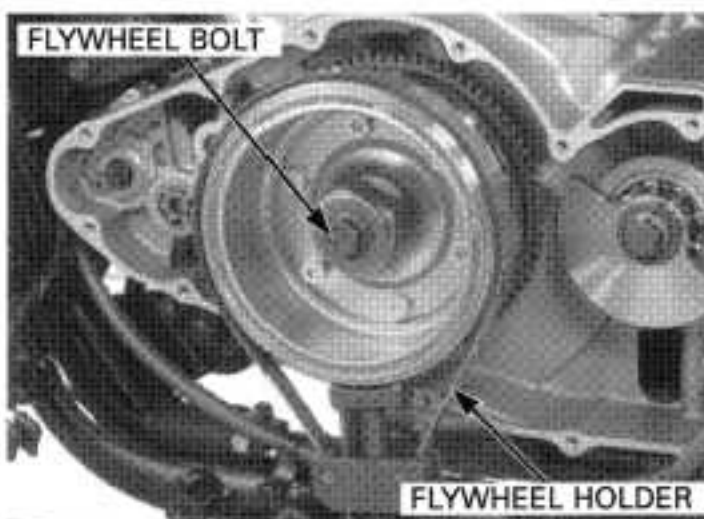

FLYWHEEL PULLER

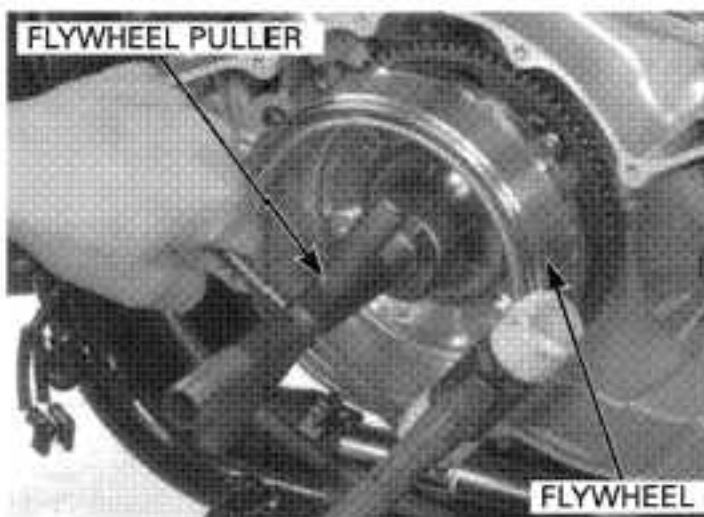

Remove the washer and starter driven gear.

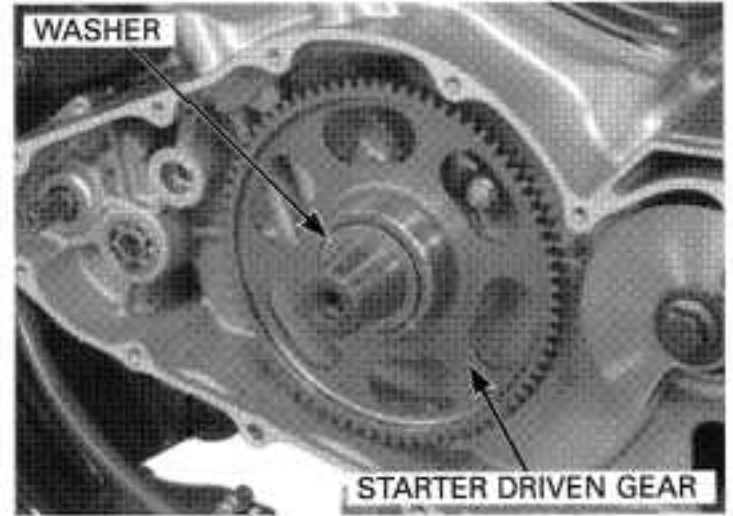

Remove the woodruff key.

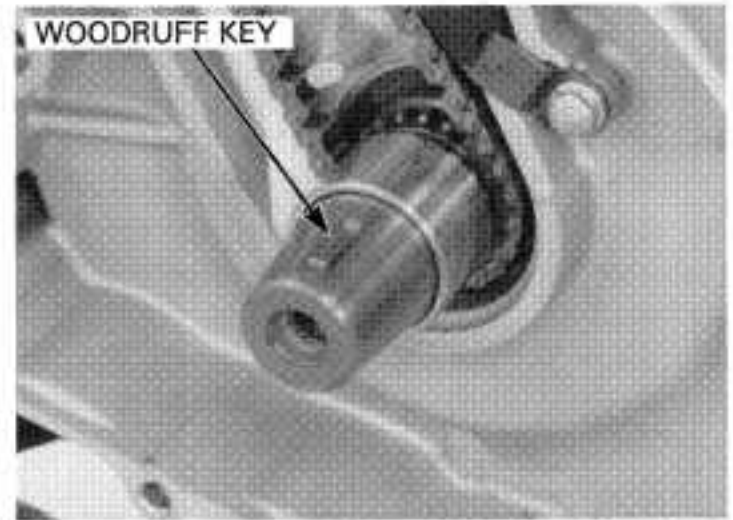

Install the starter driven gear onto the flywheel while turning it counterclockwise.

Make sure the starter driven gear turns counterclockwise smoothly and does not turn clockwise.

STARTER DRIVEN GEAR

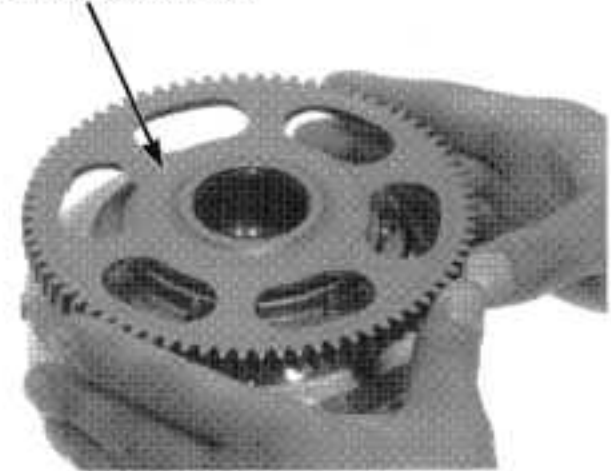

## STARTER CLUTCH REMOVAL

Remove the flywheel (page 18-14).

*Do not remove the clutch housing and one-way clutch unless it is necessary to inspect them.*

Hold the flywheel with the special tool and remove the starter clutch outer bolts.

**TOOL:**  
**Flywheel holder**

**07725-0040000**

STARTER CLUTCH OUTER BOLTS



## ELECTRIC STARTER/STARTER CLUTCH

Remove the starter clutch outer and sprag clutch from the flywheel.



### STARTER CLUTCH INSPECTION

Check the sprag clutch and clutch outer for abnormal wear or damage.

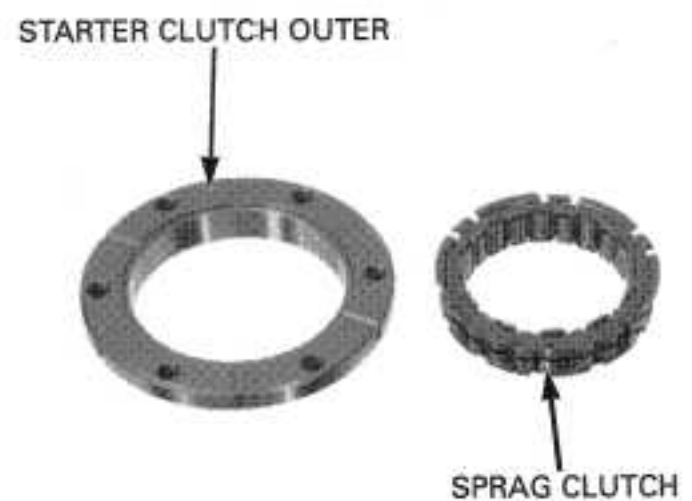

Check the needle bearing for abnormal wear or damage.

Check the starter driven gear for abnormal wear or damage.

Measure the starter driven gear O.D.

**SERVICE LIMIT: 57.639 mm (2.2692 in)**

Measure the starter driven gear I.D.

**SERVICE LIMIT: 44.10 mm (1.736 in)**

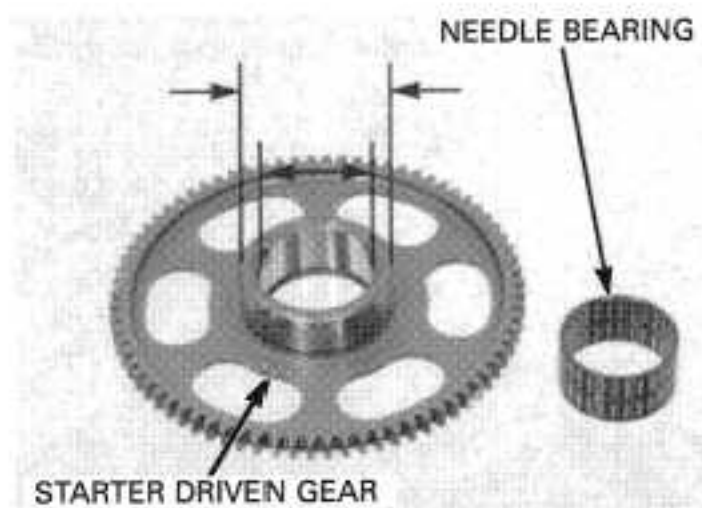

### STARTER CLUTCH INSTALLATION

*If the spring was off the clutch groove, replace the one-way clutch (clutch and spring) as an assembly.*

Apply engine oil to the sprag clutch outer surfaces. Install the sprag clutch into the starter clutch outer as shown.

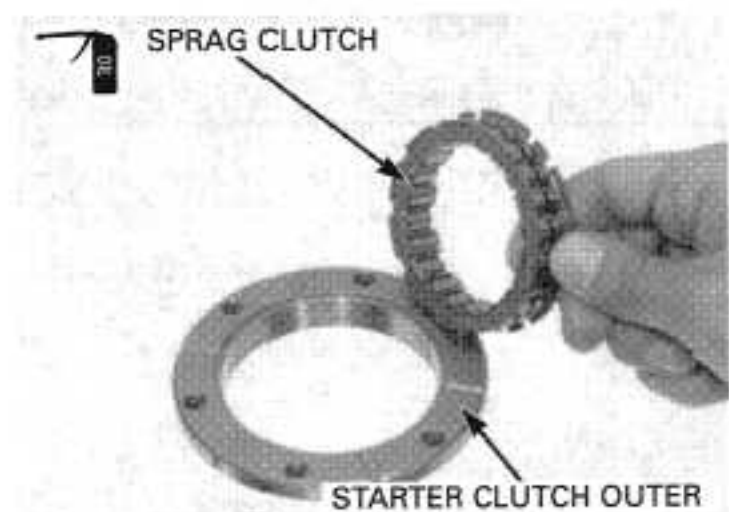

Install the starter clutch assembly onto the flywheel.

STARTER CLUTCH OUTER/SPRAG CLUTCH

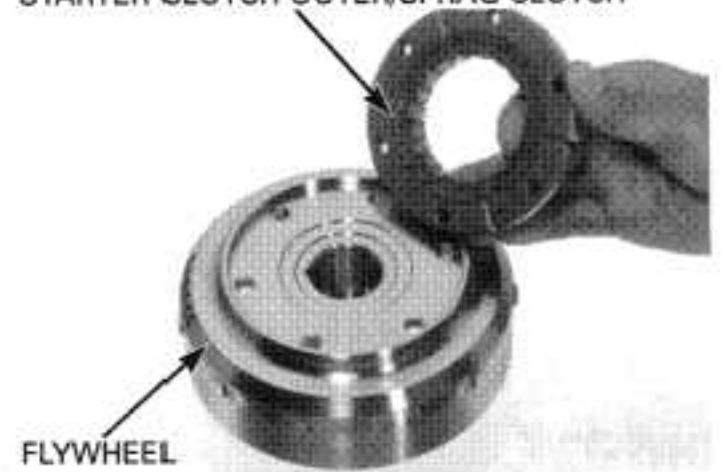

Align the bolt holes in the starter clutch outer with the holes in the flywheel.

Apply locking agent to the starter clutch bolt threads and install them.

Hold the flywheel with the special tool and tighten the starter clutch outer bolts to the specified torque.

**TOOL:**

**Flywheel holder** 07725-0040000

**TORQUE: 29 N·m (3.0 kgf·m, 22 lbf·ft)**

STARTER CLUTCH OUTER BOLTS



Install the washer to the flywheel.

Install the starter driven gear while turning it counterclockwise.

Make sure the starter driven gear turns counterclockwise smoothly and does not turn clockwise.

STARTER DRIVEN GEAR



### FLYWHEEL INSTALLATION

Clean any oil from the tapered portion of the crankshaft and flywheel.

Install the woodruff key in the crankshaft key groove.

Clean any oil from the tapered portion of the flywheel I.D.

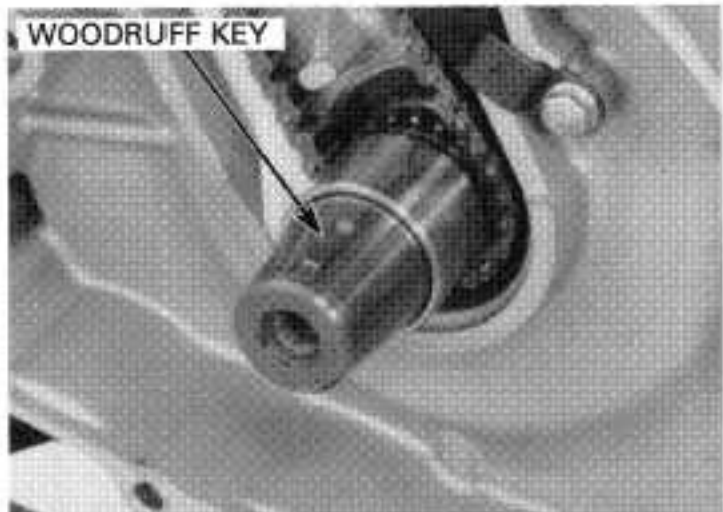



## ELECTRIC STARTER/STARTER CLUTCH

Install the flywheel on the crankshaft, aligning the key-way with the woodruff key.

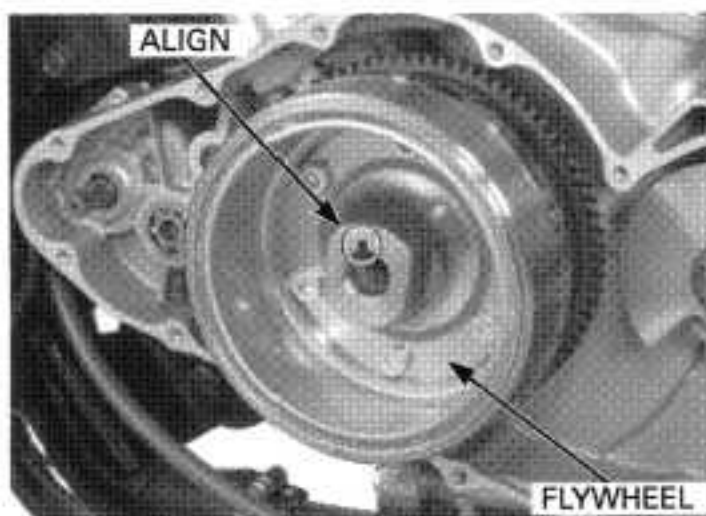

Hold the flywheel with the special tool and tighten the flywheel bolt to the specified torque.

**TOOL:**

Flywheel holder 07725-0040000

**TORQUE:** 137 N·m (14.0 kgf·m, 101 lbf·ft)

Install the left crankcase cover (page 16-11).

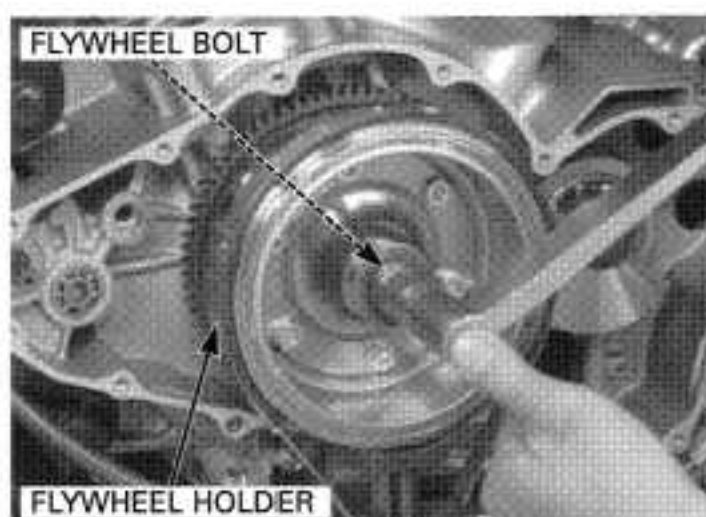

### STARTER DRIVEN GEAR/TORQUE LIMITER INSTALLATION

Install the torque limiter, shaft and starter driven gear.

Install the left crankcase cover (page 16-11).

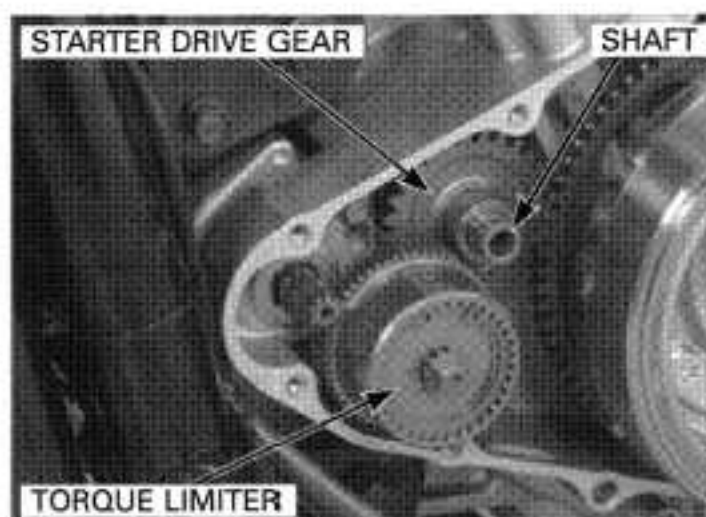

## BALANCER WEIGHT

### REMOVAL

Remove the left crankcase cover (page 16-9).  
Remove the right crankcase cover (page 10-13).

Insert the gear holder between the primary driven gear and primary drive gear.

**TOOL:**

Gear holder 07724-0010100  
not available in U.S.A.

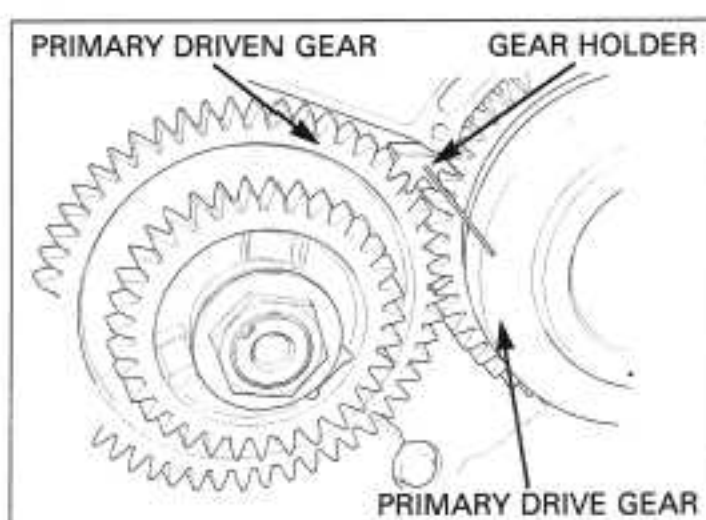



Loosen the balancer weight bolt and remove the balancer weight.

Check the balancer weight for abnormal wear or damage.

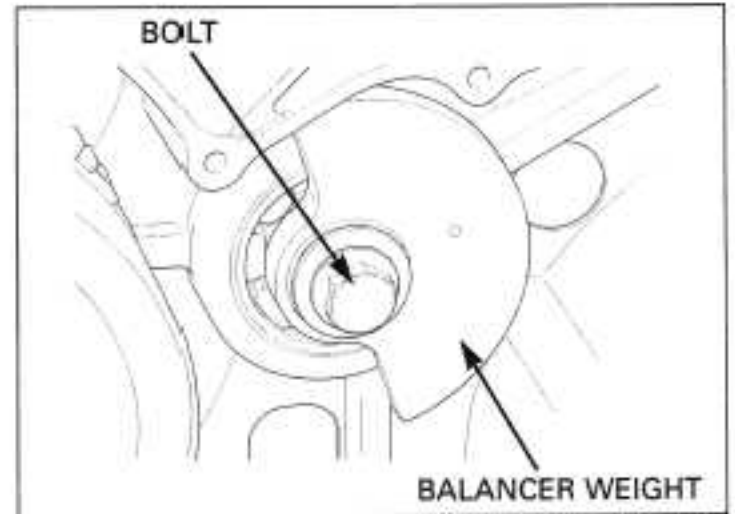

## INSTALLATION

Install the balancer weight to the balancer shaft aligning the wide groove in the balancer weight with the wide teeth on the balancer shaft.

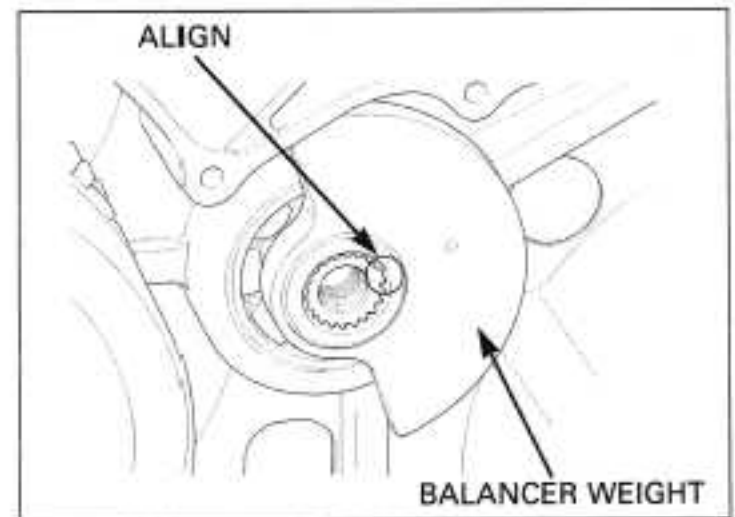

Insert the gear holder between the primary driven gear and primary drive gear.

**TOOL:**  
**Gear holder**                      **07724-0010100**  
   **not available in U.S.A.**

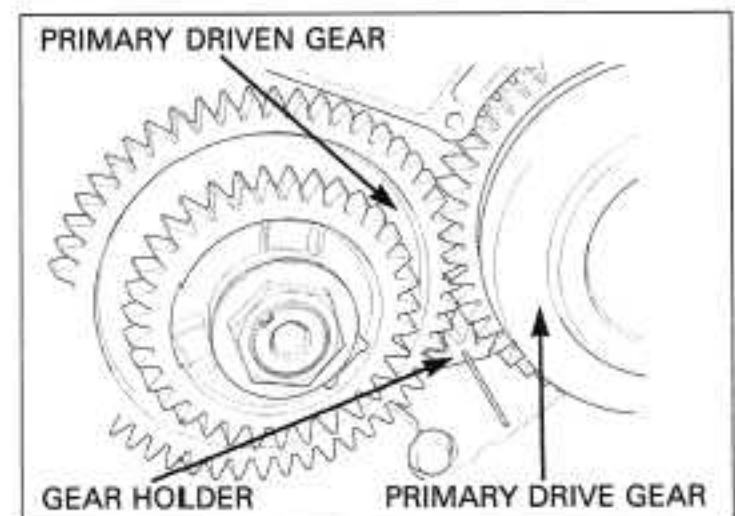

Install and tighten the balancer weight bolt to the specified torque.

**TORQUE: 98 N·m (10.0 kgf·m, 72 lbf·ft)**

Install the right crankcase cover (page 10-14).  
Install the left crankcase cover (page 16-11).

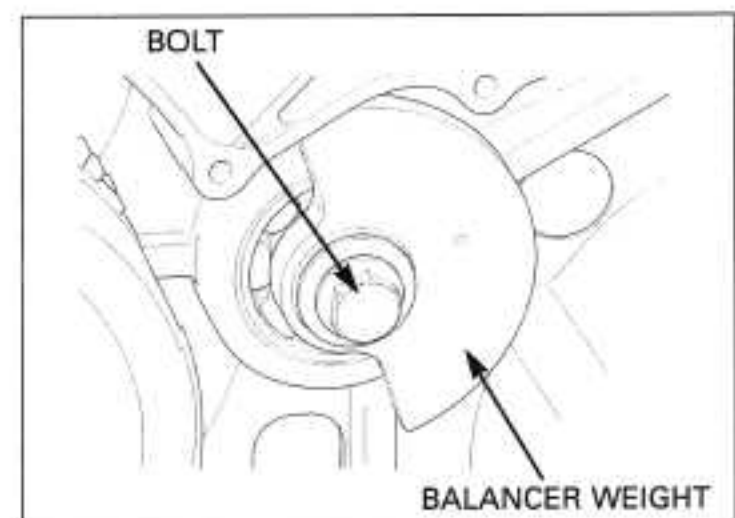

## LIGHTS/METERS/SWITCHES

---

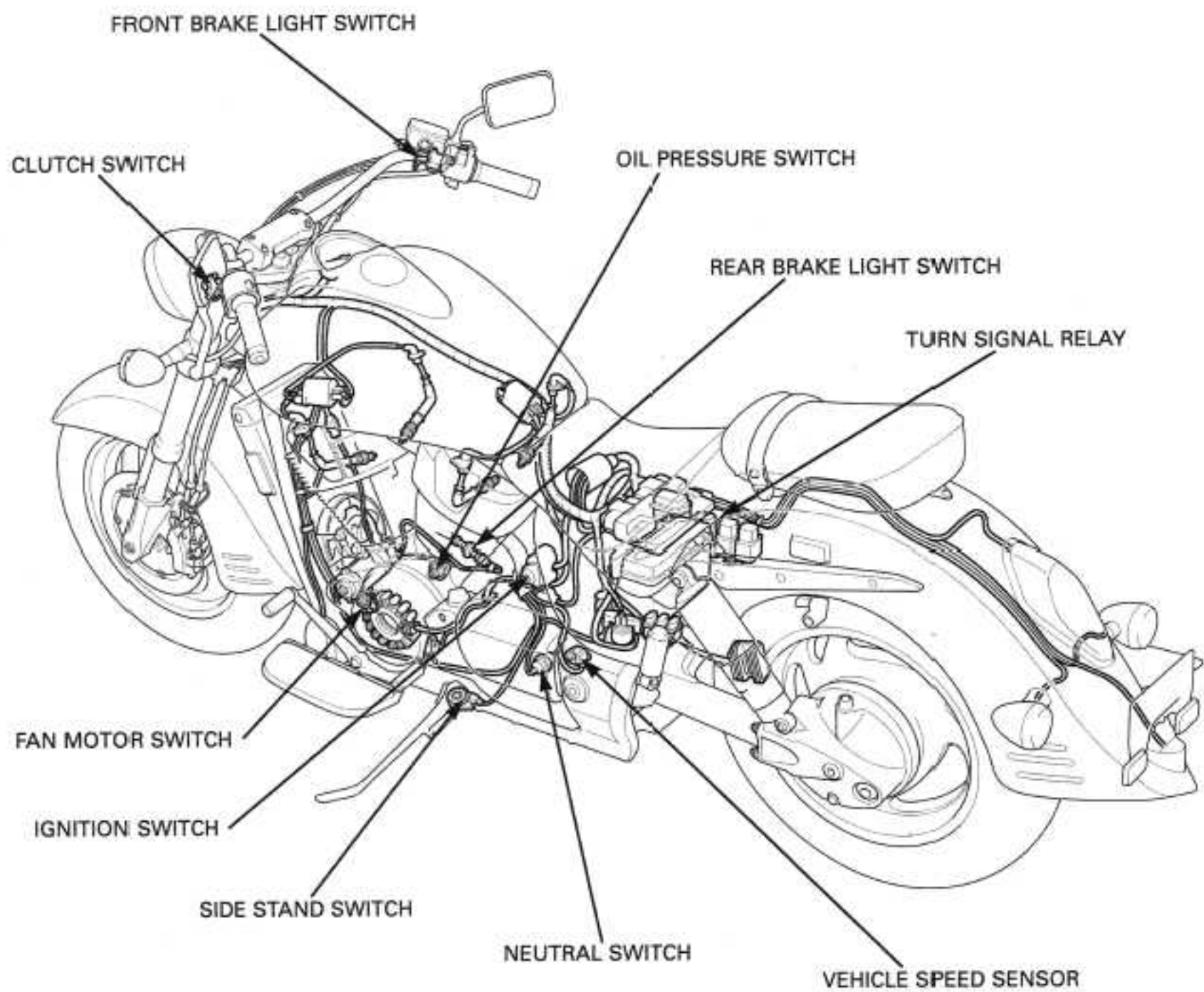

# 19. LIGHTS/METERS/SWITCHES

SERVICE INFORMATION	19-1	CLUTCH SWITCH	19-12
TROUBLESHOOTING	19-3	IGNITION SWITCH	19-13
HEADLIGHT	19-4	HANDLEBAR SWITCH	19-14
TURN SIGNALS	19-5	FAN MOTOR SWITCH	19-15
TAIL/BRAKE LIGHT	19-6	COOLANT TEMPERATURE INDICATOR	19-16
LICENSE LIGHT	19-6	SIDE STAND SWITCH	19-17
SPEEDOMETER/INDICATOR BOX	19-7	OIL PRESSURE INDICATOR	19-18
VEHICLE SPEED SENSOR	19-9	HORN	19-19
NEUTRAL SWITCH	19-11	TURN SIGNAL RELAY	19-20
FRONT BRAKE LIGHT SWITCH	19-12	FUEL RESERVE SENSOR	19-20
REAR BRAKE LIGHT SWITCH	19-12		

## SERVICE INFORMATION

### GENERAL

- A halogen headlight bulb becomes very hot while the headlight is on, and remains hot for a while after it is turned off. Be sure to let it cool down before servicing.
- Use an electric heating element to heat the water/coolant mixture for the thermo sensor inspection. Keep all flammable materials away from the electric heating element. Wear protective clothing, insulated gloves and eye protection.
- Note the following when replacing the halogen headlight bulb.
  - Wear clean gloves while replacing the bulb. Do not put fingerprints on the headlight bulb, as they may create hot spots on the bulb and cause it to fail.
  - If you touch the bulb with your bare hands, clean it with a cloth moistened with alcohol to prevent early bulb failure.
  - Be sure to install the dust cover after replacing the bulb.
- Check the battery condition before performing any inspection that requires proper battery voltage.
- A continuity test can be made with the switches installed on the motorcycle.
- The following color codes used are indicated throughout this section.

Bu: Blue	G: Green	Lg: Light Green	R: Red
Bl: Black	Gr: Gray	O: Orange	W: White
Br: Brown	Lb: Light Blue	P: Pink	Y: Yellow

## LIGHTS/METERS/SWITCHES

### SPECIFICATION

ITEM			SPECIFICATIONS
Bulbs	Headlight	Hi	12V – 60W
		Lo	12V – 55W
	Brake/tail light		12V – 21/5W
	Front turn signal/running light		12V – 21/5W x 2
	Rear turn signal light		12V – 21W x 2
	License light		12V – 5W
	Instrument light		L.E.D.
	Turn signal indicator		L.E.D.
	High beam indicator		L.E.D.
	Neutral indicator		L.E.D.
	Oil pressure indicator		L.E.D.
	PGM-FI warning indicator		L.E.D.
	Coolant temperature indicator		L.E.D.
	Fuel reserve indicator		L.E.D.
Fuse	Main fuse		30 A
	PGM-FI fuse		30 A
	Sub fuse		10 A x 4, 20 A x 2
Fan motor switch	Start to close (ON)		98 – 102 °C (208 – 216 °F)
	Stop to open		93 – 97 °C (199 – 207 °F)

### TORQUE VALUES

Speedometer/indicator box socket bolt	2.5 N•m (0.25 kgf•m, 1.8 lbf•ft)
Speedometer/indicator box screw	1.3 N•m (0.13 kgf•m, 0.9 lbf•ft)
Neutral switch	12 N•m (1.2 kgf•m, 9 lbf•ft)
Ignition switch mounting bolt	10 N•m (1.0 kgf•m, 7 lbf•ft)
Ignition switch rear cover screw	2 N•m (0.2 kgf•m, 1.4 lbf•ft)
Horn mounting bolt	21 N•m (2.1 kgf•m, 15 lbf•ft)
Fan motor switch	17 N•m (1.7 kgf•m, 12 lbf•ft)
Side stand switch bolt	10 N•m (1.0 kgf•m, 7 lbf•ft)
ECT sensor	18 N•m (1.8 kgf•m, 13 lbf•ft)

ALOC bolt: replace with a new one.

# TROUBLESHOOTING

## VEHICLE SPEED SENSOR/SPEEDOMETER

The odometer/trip meter operates normally, but the speedometer does not operate

- Faulty speedometer

The speedometer operates normally, but the odometer/trip meter does not operate

- Faulty odometer/trip meter

The speedometer operation is abnormal

- Check for the following before diagnosing
  - Blown main or sub fuses
  - Loose or corroded terminals of the connectors
  - Discharged battery

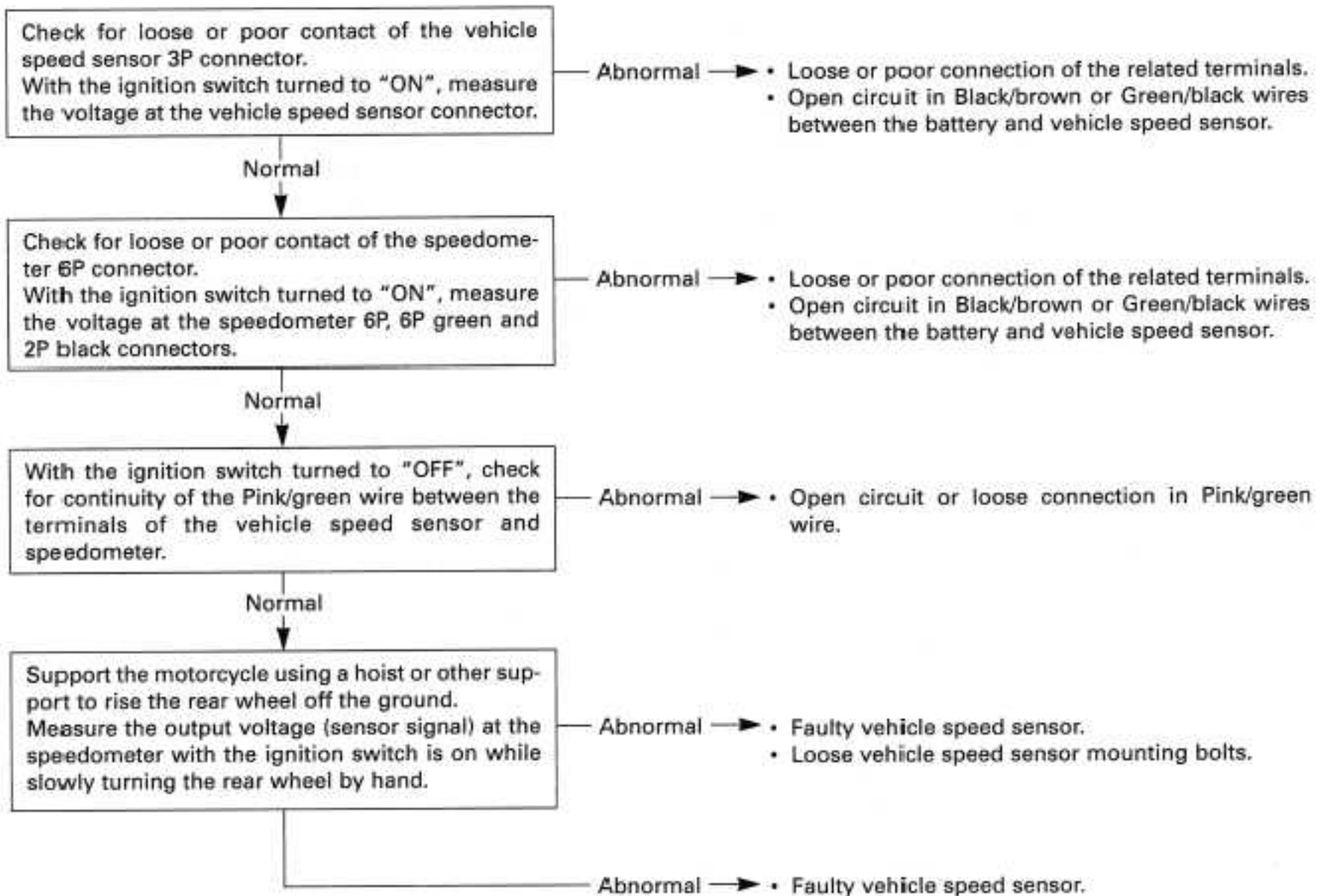



## HEADLIGHT

### BULB REPLACEMENT

A halogen headlight bulb becomes very hot while the headlight is on, and remains hot for a while after it is turned off. Be sure to let it cool down before servicing.

Remove the screws.

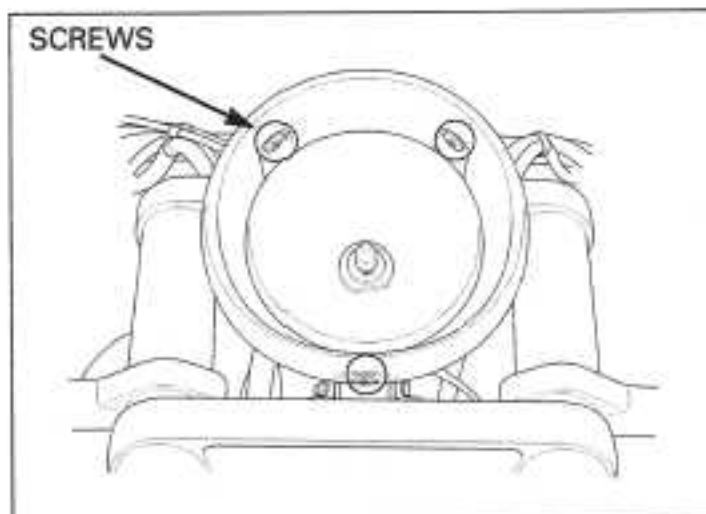

Remove the headlight from the case.

Disconnect the headlight 3P connector and remove the dust cover.

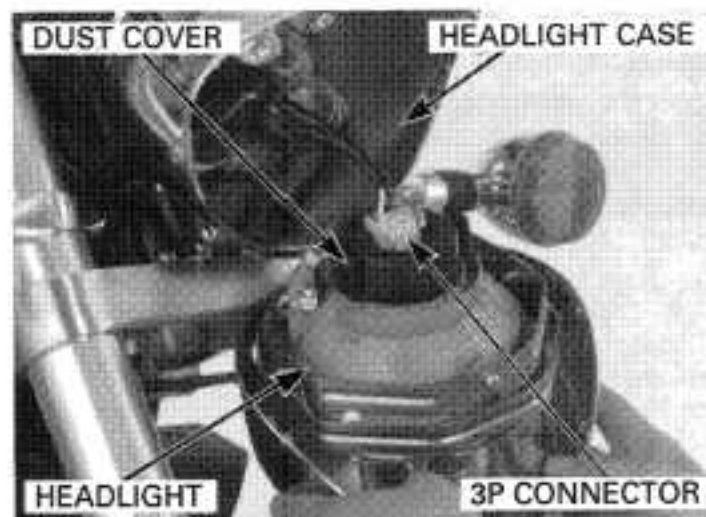

Release the bulb retainer and replace the headlight bulb.

#### NOTICE

*Avoid touching the halogen headlight bulb. Fingerprints can create hot spots that will cause the bulb to break.*

If you touch the bulb with your bare hands, clean it with a cloth moistened with denatured alcohol to prevent early bulb failure.

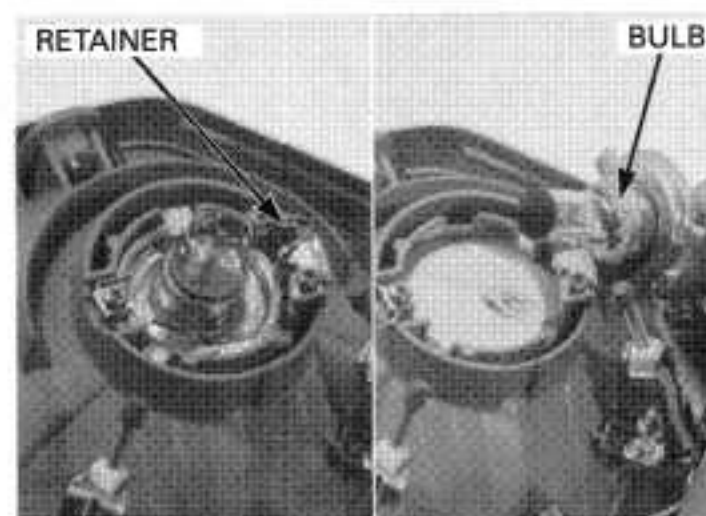

Install the dust cover tightly against the headlight with the "TOP" mark facing up.

Install the headlight in the reverse order of removal.

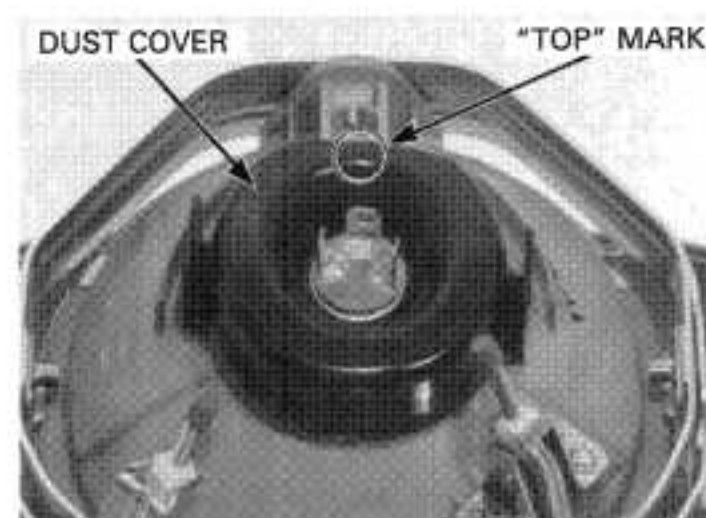

### HEADLIGHT CASE REMOVAL/INSTALLATION

Remove the headlight (page 19-4).

Release the wire clamps and disconnect the connectors.  
Remove the connectors from the headlight case hole.

Remove the bolts and cap nuts.  
Remove the headlight case.

Installation is in the reverse order of removal.



## TURN SIGNALS

### BULB REPLACEMENT

Remove the screw and turn signal lens.

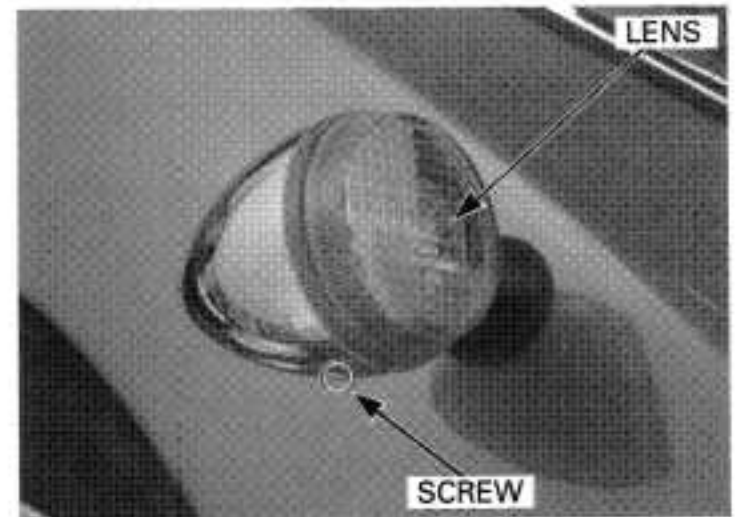

While pushing in, turn the bulb counterclockwise to remove it and replace with a new one.

Install the bulb in the reverse order of removal.

When installing the lens, align the lens groove with the case tab.

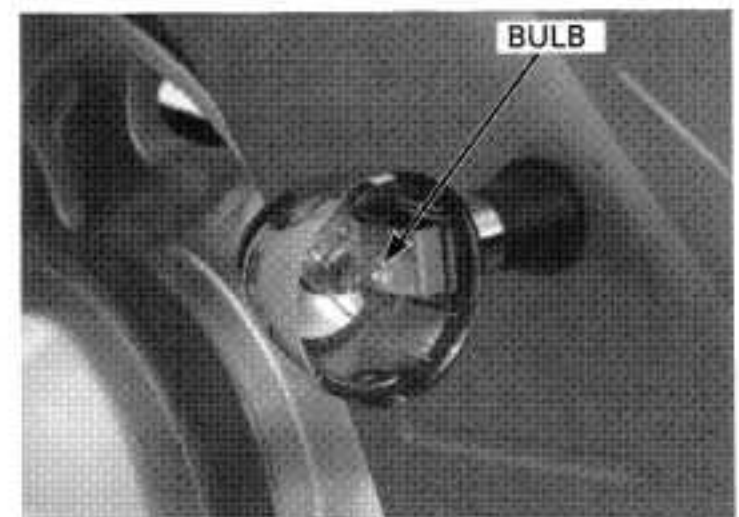

### FRONT TURN SIGNAL ASSEMBLY REMOVAL/INSTALLATION

Remove the headlight (page 19-4).

Disconnect the turn signal connectors.

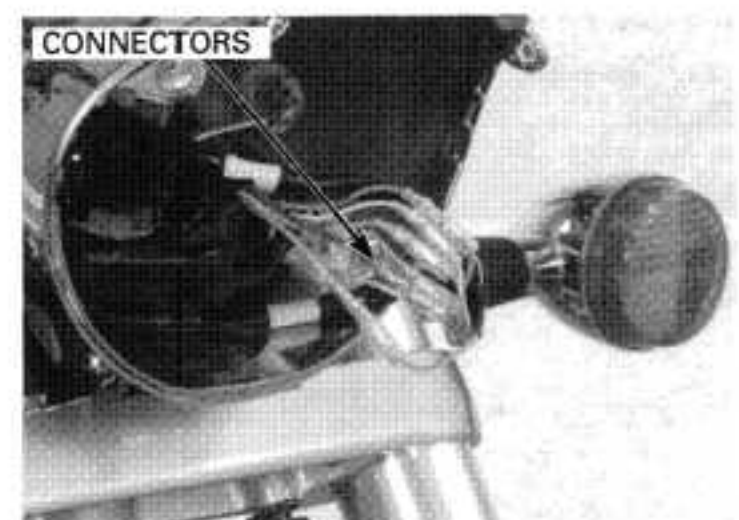

## LIGHTS/METERS/SWITCHES

Remove the bolt, holder and turn signal assembly.

*Route the turn signal wire properly (page 1-23).*

Installation is in the reverse order of removal.

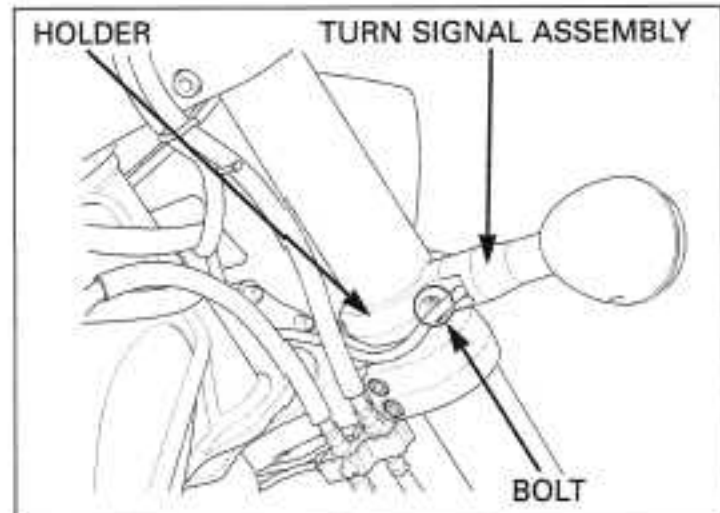

## TAIL/BRAKE LIGHT

### BULB REPLACEMENT

Remove the screws and tail/brake light lens.

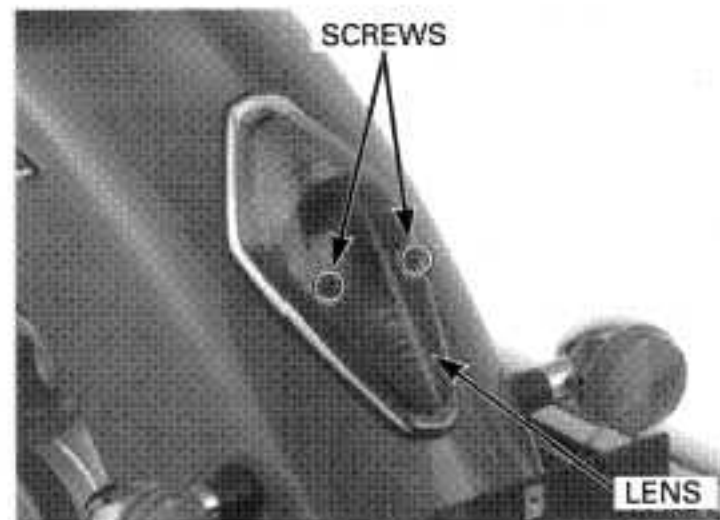

While pushing in, turn the bulb counterclockwise to remove it and replace with a new one.

Install the bulb in the reverse order of removal.

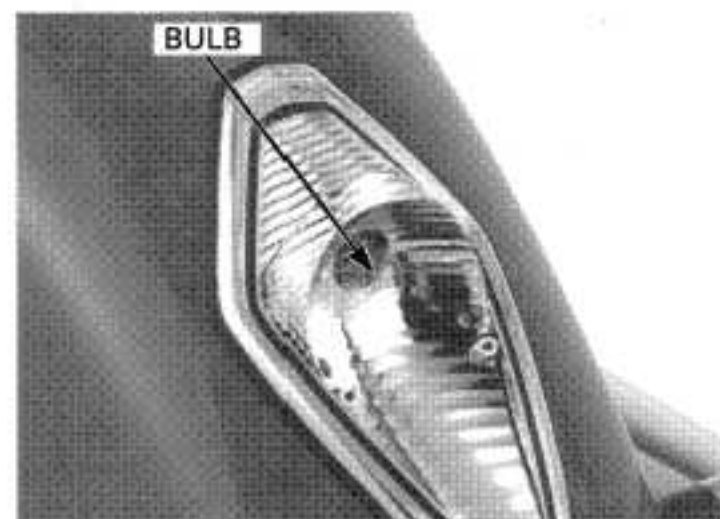

## LICENSE LIGHT

### BULB REPLACEMENT

Remove the bolt and cover.

Turn the bulb socket counterclockwise and remove the bulb socket.

Remove bulb and replace with a new one.

Install the bulb in the reverse order of removal.

*At installation, align the tab on the cover with the hole in the rear fender.*

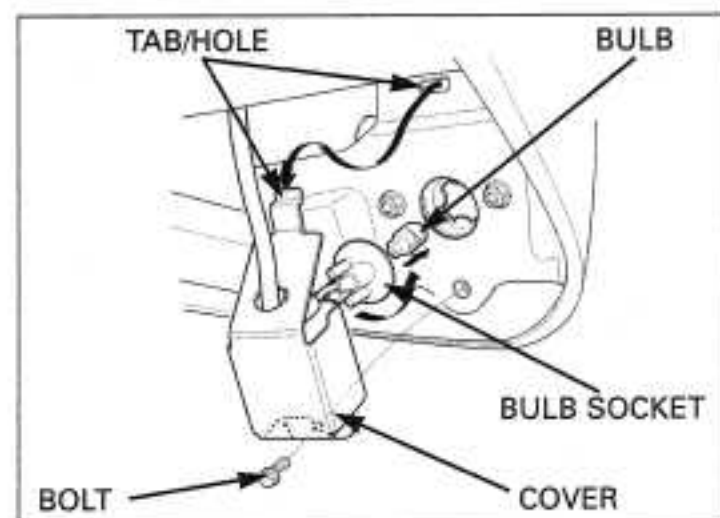

## SPEEDOMETER/INDICATOR BOX

### REMOVAL/INSTALLATION

Remove the headlight (page 19-4).

Disconnect the speedometer/indicator box 6P connector, 6P green and 2P black connectors.

Remove the fuel tank cap using the ignition key.

Remove the socket bolts, washers and fuel tank cover/speedometer/indicator box as an assembly.

Installation is in the reverse order of removal.

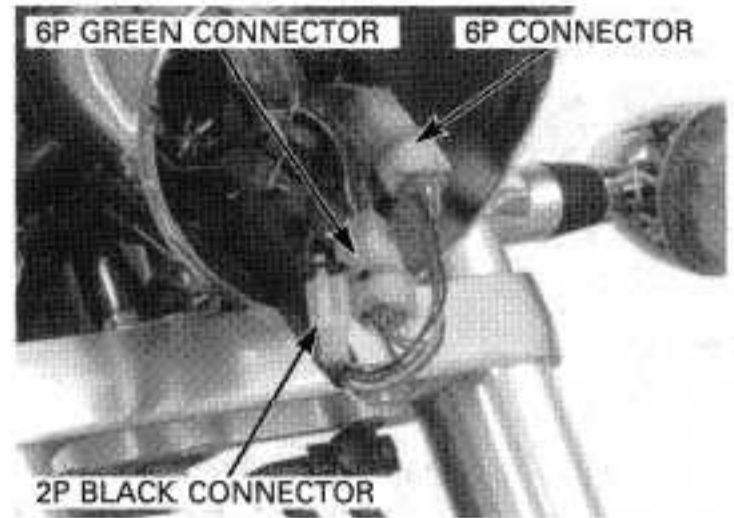

### DISASSEMBLY

Remove the fuel tank cover/speedometer/indicator box (see above).

Remove the reset switch cap.  
Remove the socket bolts and washers.

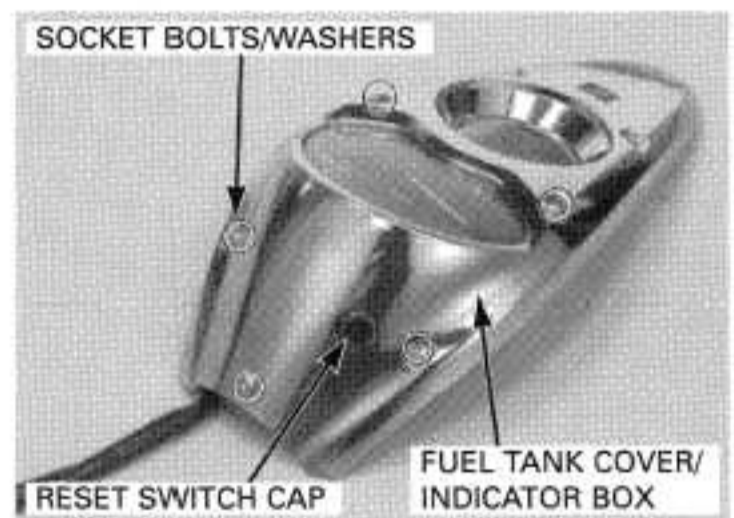

Remove the reset switch from the fuel tank cover.  
Remove the speedometer/indicator box and stay from the fuel tank cover.





## LIGHTS/METERS/SWITCHES

Remove the screws and speedometer/indicator box from the stay.  
Remove the screws and reset switch wires from the speedometer/indicator box.

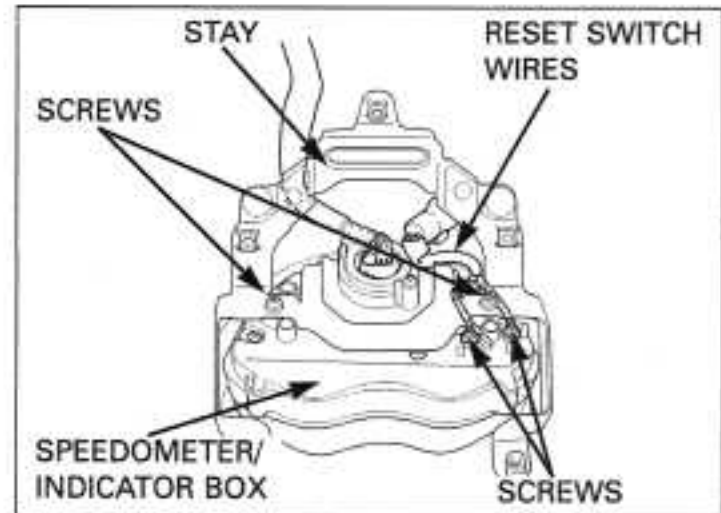

Remove the screws and the lens.  
Remove the screws and speedometer/indicator box from the case.

### ASSEMBLY

Install the speedometer/indicator box to the case and tighten the screws securely.

Install the lens and tighten the screws securely.

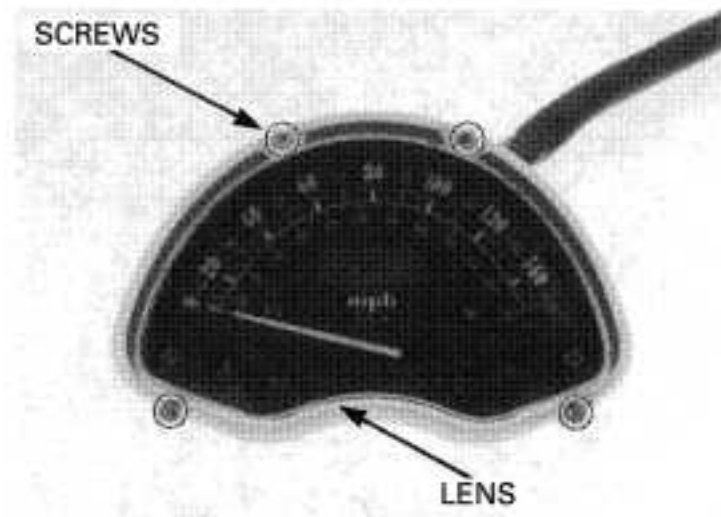

Install the reset switch wires to the speedometer/indicator box and tighten the screws securely.

Temporarily install the speedometer/indicator box to the stay.

Temporarily tighten the screws.

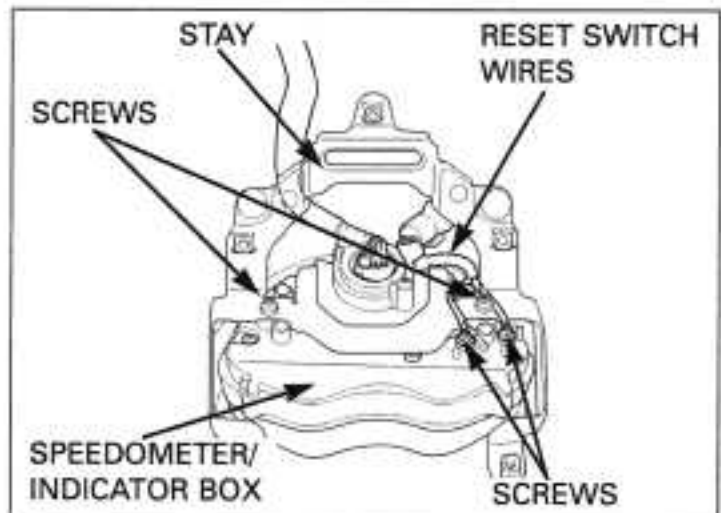

Install the speedometer/indicator box to the fuel tank cover.  
Install the reset switch to the fuel tank cover securely.

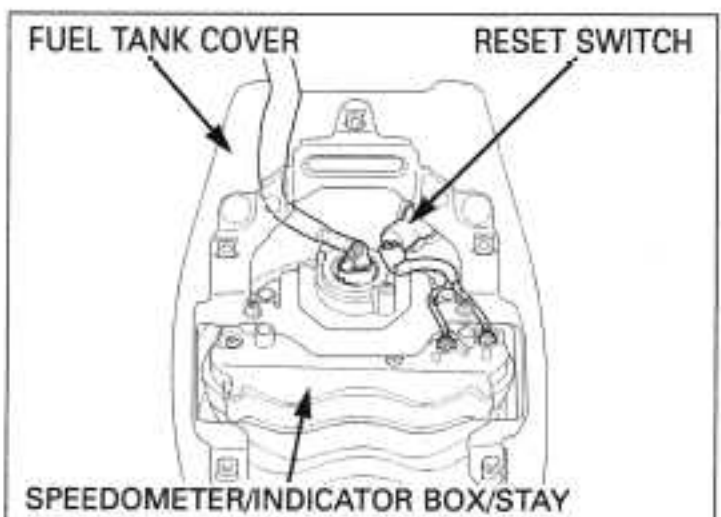



Install the reset switch cap.  
 Install the socket bolts and washers.  
 Tighten the socket bolts to the specified torque.

**TORQUE: 2.5 N·m (0.25 kgf·m, 1.8 lbf·ft)**

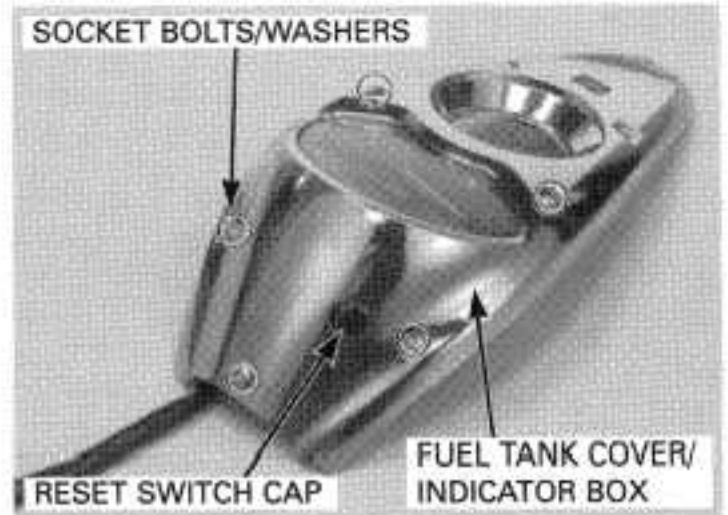

Tighten the speedometer/indicator box screws to the specified torque.

**TORQUE: 1.3 N·m (0.13 kgf·m, 0.9 lbf·ft)**

Install the fuel tank cover/speedometer/indicator box (page 19-7).

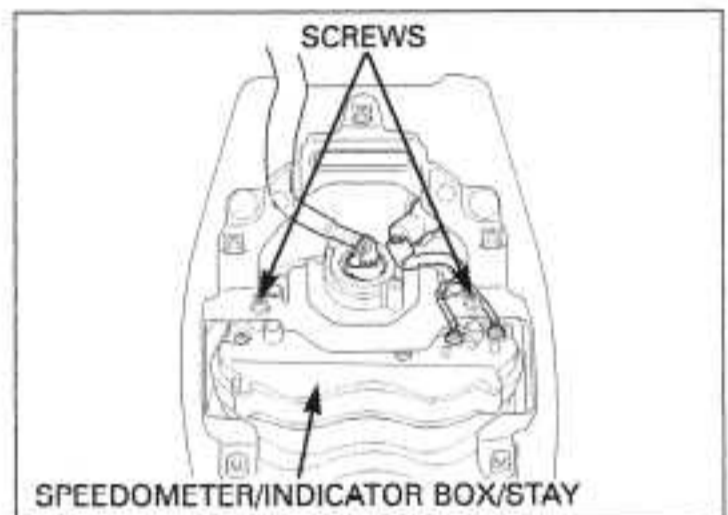

## VEHICLE SPEED SENSOR

### VOLTAGE INSPECTION

Remove the left rear crankcase cover (page 2-3).

Disconnect the vehicle speed sensor 3P connector and check for loose or poor contact of the connector.

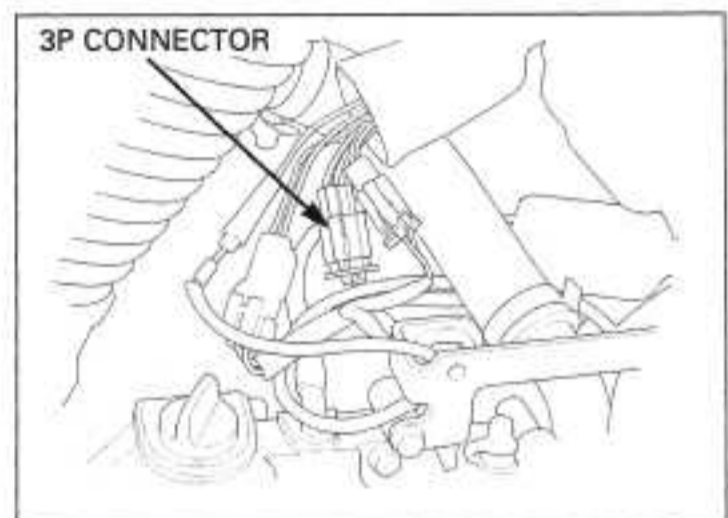

With the ignition switch turned to "ON", measure the voltage of the vehicle speed sensor 3P connector at the wire harness side.

**CONNECTION: Black/brown (+) – Green/black (-)**  
**STANDARD: Battery voltage**

If there is no voltage, replace and repair the wire harness.

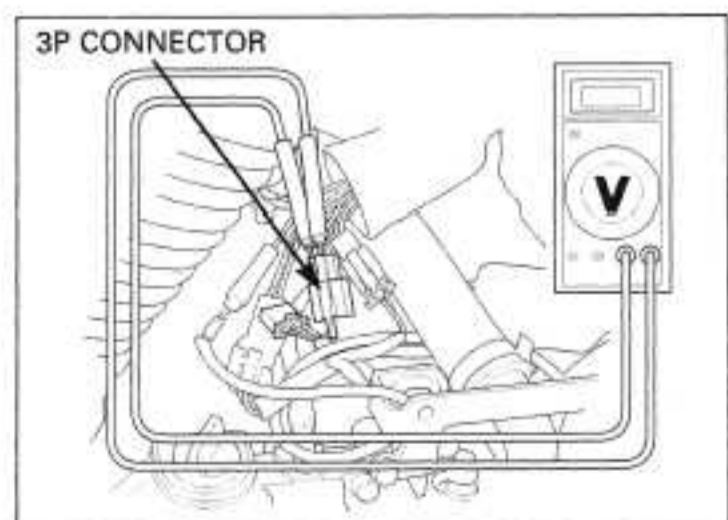

## LIGHTS/METERS/SWITCHES

Remove the headlight (page 19-4).

Check for loose or poor connection of the speedometer 6P connector, 6P green and 2P black connectors.

With the ignition switch turned to "ON", measure the voltage at the speedometer 6P and 2P black connectors.

**CONNECTION:** Black/brown (+) – Green/black (-)  
**STANDARD:** Battery voltage

If there is no voltage, replace and repair the wire harness.

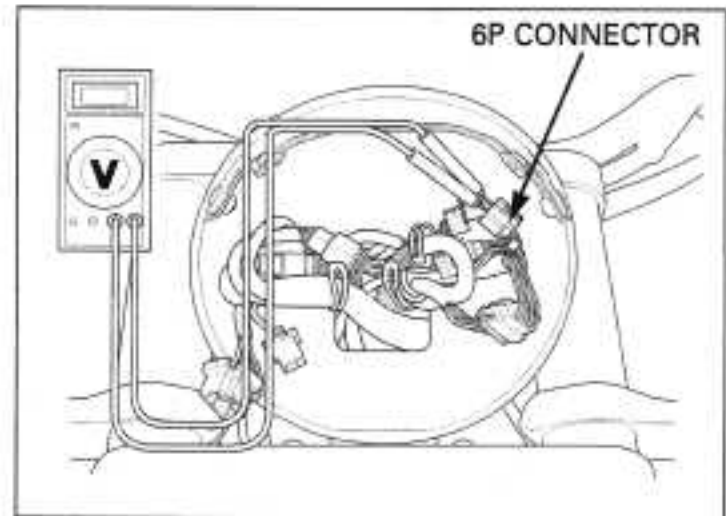

### OUTPUT SIGNAL INSPECTION

With the ignition switch turned to "OFF", check for continuity of the Pink/green wire between the speed sensor 3P connector and speedometer 6P connector, 6P green and 2P black connectors.

There should be continuity.

If there is no continuity, replace and repair the wire harness.

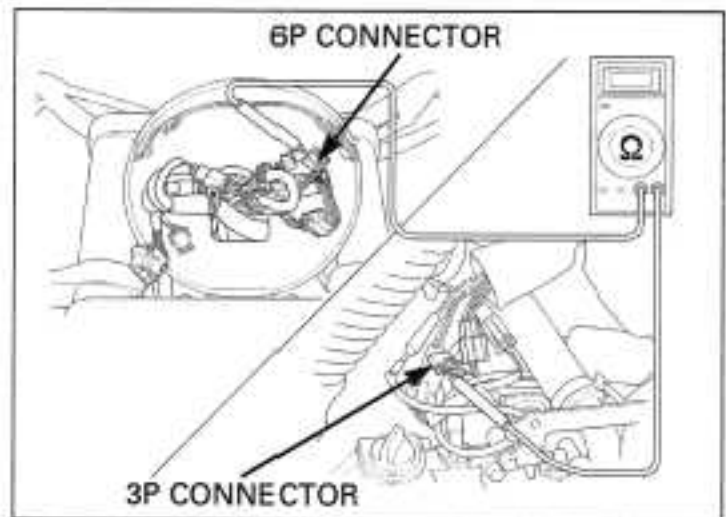

Connect the vehicle speed sensor 3P connector. Measure the voltage at the speedometer 6P green and 2P black connectors with the ignition switch turned to "ON" while slowly turning the rear wheel by hand.

**CONNECTION:** Pink/green (+) – Green/black (-)  
**STANDARD:** Repeat 0 to 5 V

If the measurement is out of specification, inspect for an open circuit in the wire harness.

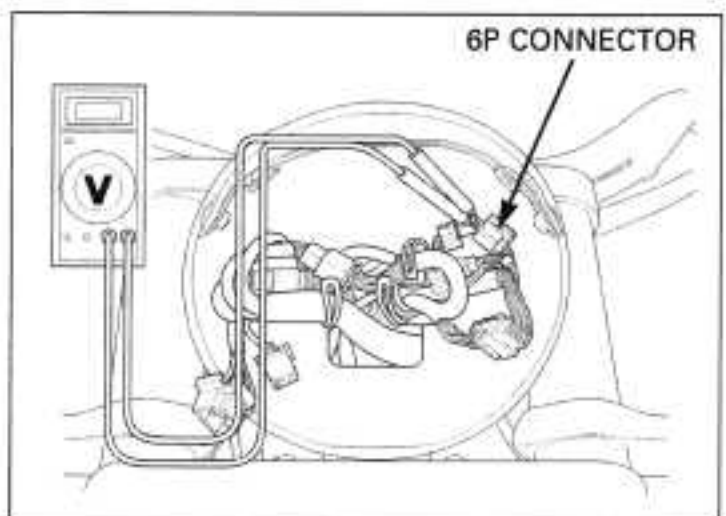

### REMOVAL/INSTALLATION

Remove the left rear crankcase cover (page 2-2).

Disconnect the vehicle speed sensor 3P connector.

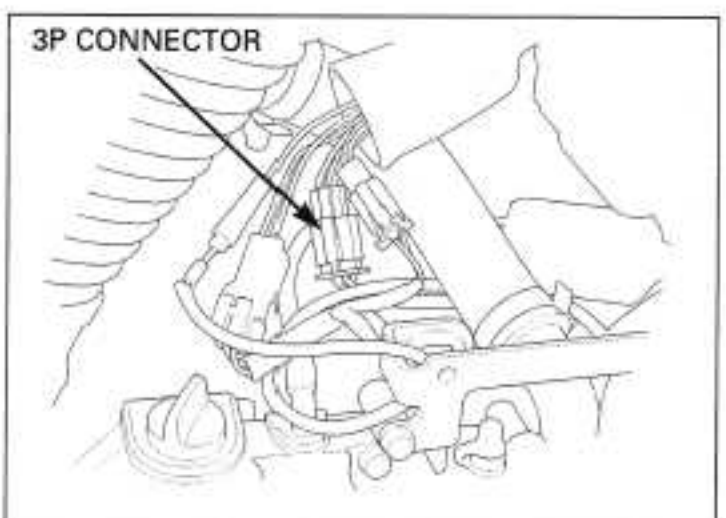

Remove the bolts and vehicle speed sensor.

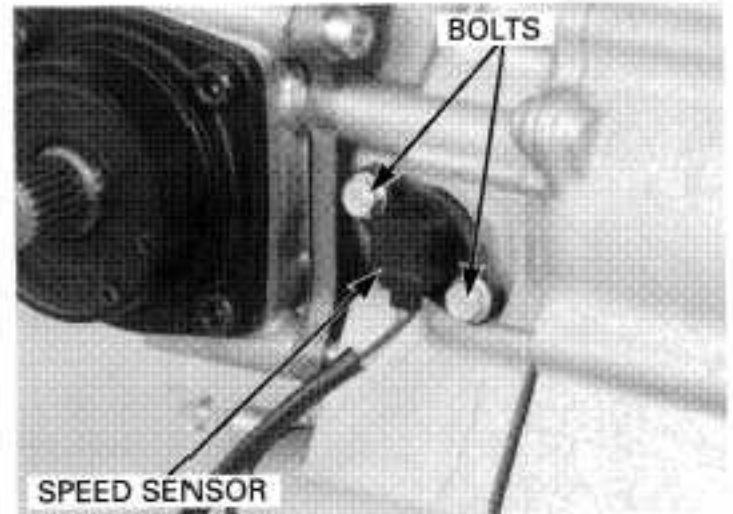

Check that the O-ring is in good condition, replace if necessary.

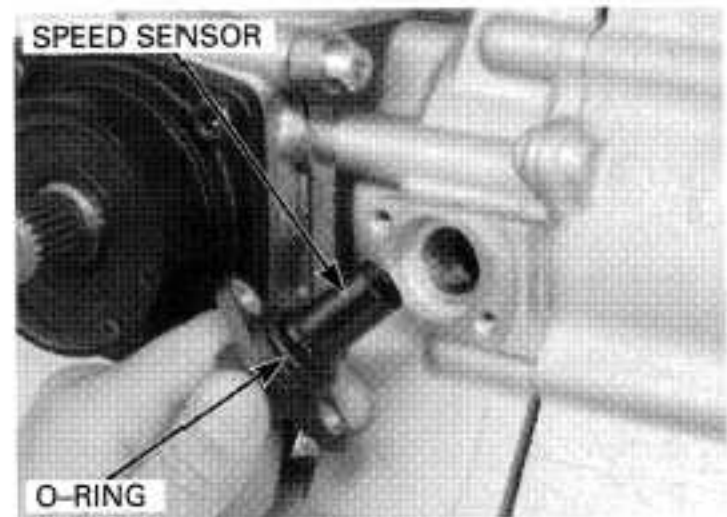

Installation is in the reverse order of removal.

*Route the speedometer wire properly (page 1-23).*

## NEUTRAL SWITCH

### INSPECTION

Remove the left rear crankcase cover (page 2-3).

Disconnect the neutral switch connector.

Shift the transmission into neutral and check for continuity between the Light green wire terminal and ground.

There should be continuity when the transmission is in neutral, and no continuity when the transmission is in gear.

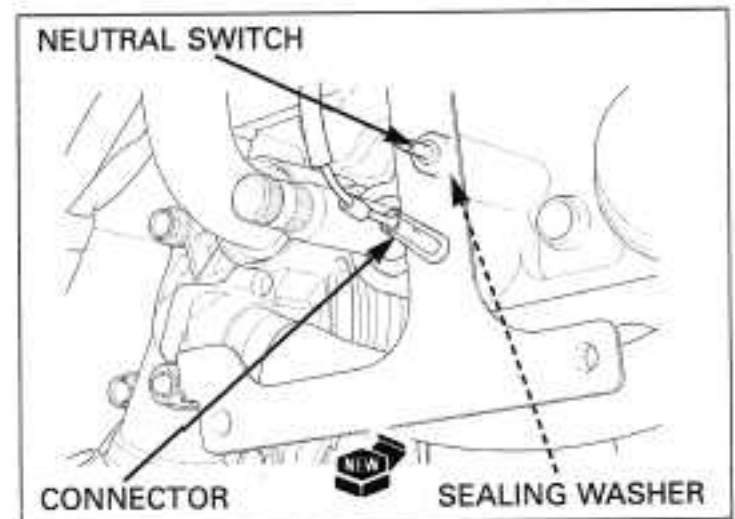

### REMOVAL/INSTALLATION

Remove the left rear crankcase cover (page 2-3).

Disconnect the neutral switch connector.  
Remove the neutral switch and sealing washer.

Replace the sealing washer with new one.

**TORQUE: 12 N·m (1.2 kgf·m, 9 lbf·ft)**

Installation is in the reverse order of removal.

## FRONT BRAKE LIGHT SWITCH

Disconnect the front brake light switch wires and check for continuity.

There should be continuity with the front brake applied and no continuity with it released.

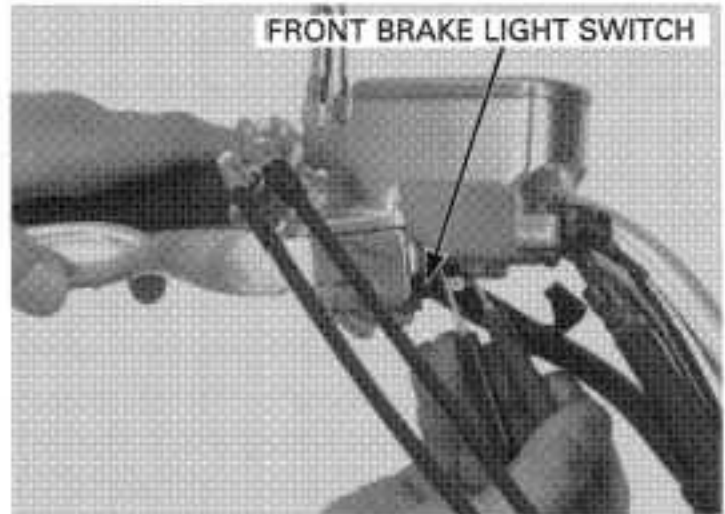

## REAR BRAKE LIGHT SWITCH

Disconnect the rear brake light switch 2P connector and check for continuity at the switch side connector terminals.

There should be continuity with the rear brake applied and no continuity with it released.

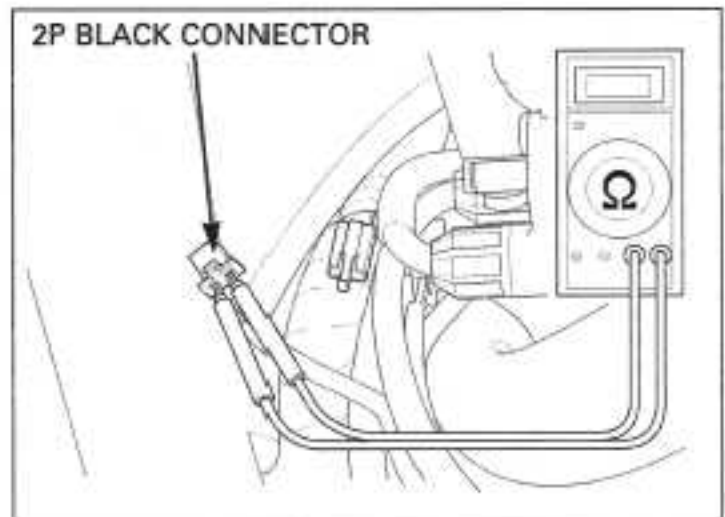

## CLUTCH SWITCH

Disconnect the clutch switch wires and check for continuity.

There should be continuity with the clutch lever squeezed and no continuity with it released.

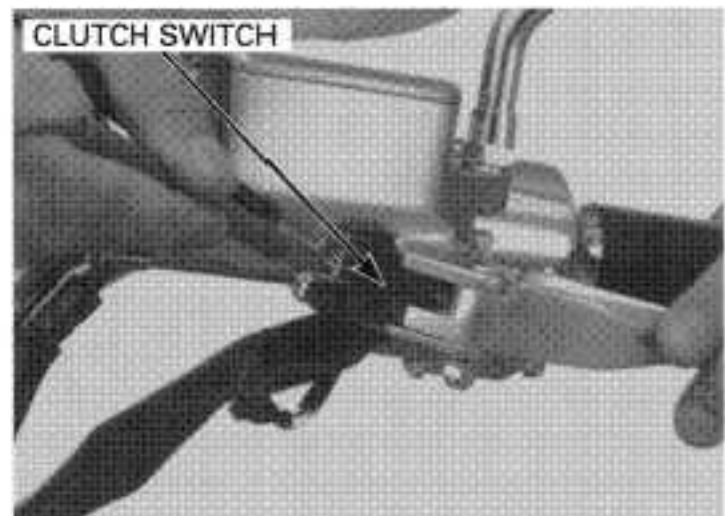



# IGNITION SWITCH

## INSPECTION

Remove the seat (page 2-2).

Disconnect the ignition switch 4P connector. Check for continuity between the terminals. Continuity should exist between the color coded wires as shown in the following chart.

	FAN	IG	BAT1
ON	○	○	○
OFF			
LOCK			
COLOR	Bu/O	R/Bl	R

## REMOVAL/INSTALLATION

Remove the seat (page 2-2).

Disconnect the ignition switch 4P connector.

Remove the screw and ignition switch cover.

Remove the bolts and ignition switch.

Installation is in the reverse order of removal.

**TORQUE: 10 N·m (1.0 kgf·m, 7 lbf·ft)**

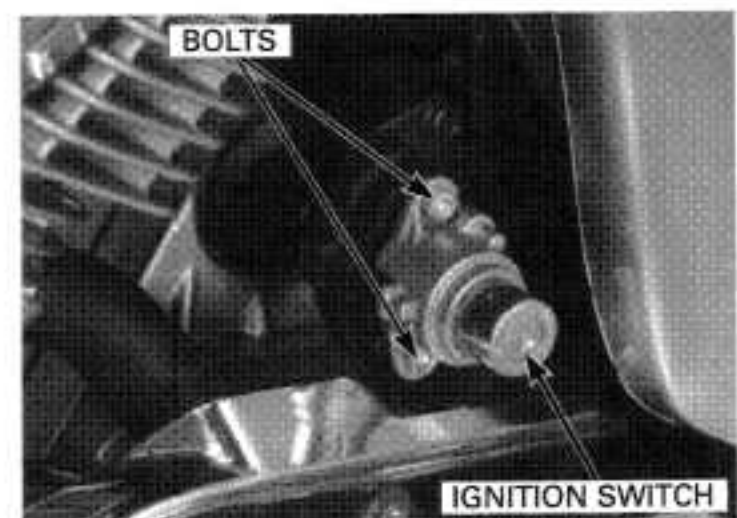
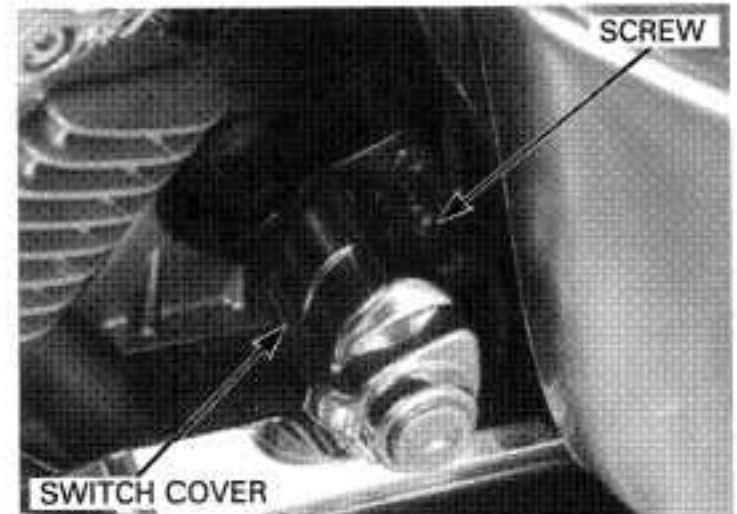
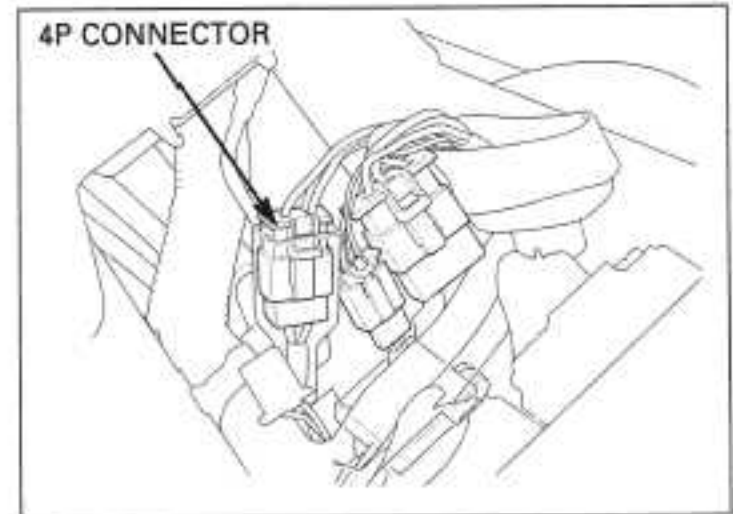
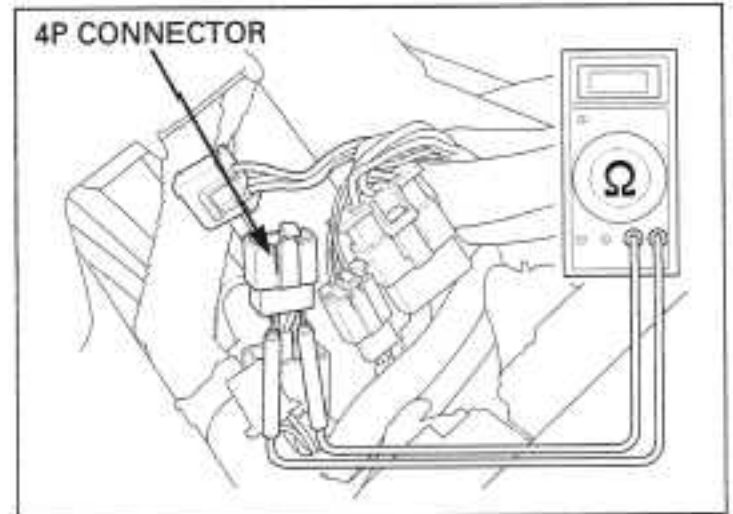



## HANDLEBAR SWITCH

Remove the headlight (page 19-4).

Check for continuity between the terminals. Continuity should exist between the color coded wires in each chart.

### LEFT HANDLEBAR SWITCH

Disconnect the left handlebar 6P blue and 6P black connectors.

#### HORN SWITCH

	HO	BAT3
FREE		
PUSH	○ — ○	○ — ○
COLOR	Lg	W/G

#### TURN SIGNAL SWITCH

	Turn signal			Position		
	L	W	R	PO	PL	PR
R		○ — ○		○ — ○		
N				○ — ○ — ○		
L	○ — ○			○ — ○		
COLOR	O	Gr	Sb	Bl/Br	O/W	Sb/W

#### DIMMER SWITCH

	HL2	LO	HI
Lo	○ — ○		
(N)	○ — ○ — ○		
Hi	○ — ○		
COLOR	Bu/W	W	Bu

### RIGHT HANDLEBAR SWITCH

Disconnect the right handlebar 6P red connector.

#### STARTER SWITCH

	IG	ST	BAT1	HL
FREE			○ — ○	
PUSH	○ — ○			
COLOR	Bl/W	Y/R	Bl/R	Bu/W

#### ENGINE STOP SWITCH

	BAT2	IG
OFF		
RUN	○ — ○	○ — ○
COLOR	W/Bl	Bl/W

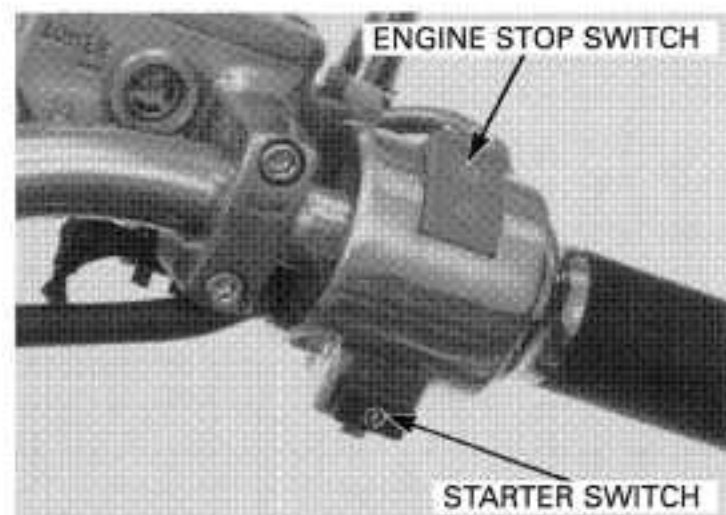
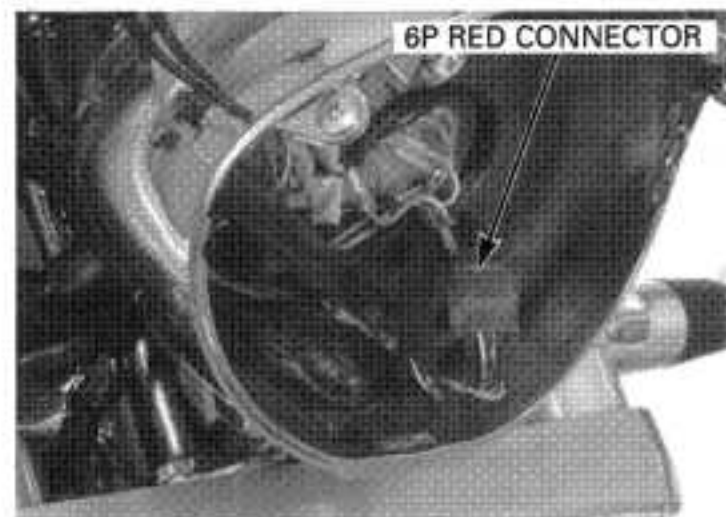
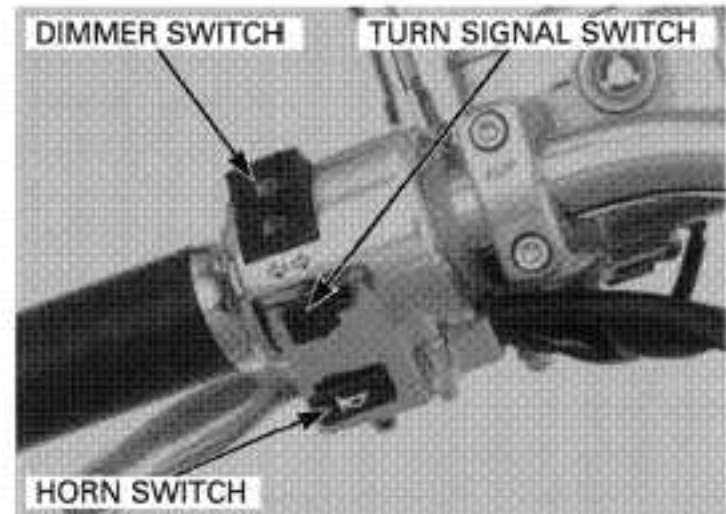
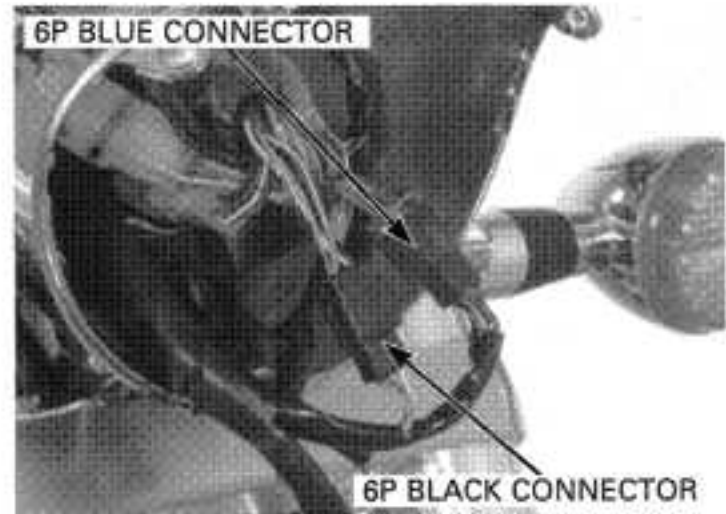

## FAN MOTOR SWITCH

### INSPECTION

Remove the lower radiator cover (page 6-7).

#### Fan motor does not stop

Turn the ignition switch to "OFF", disconnect the connector from the fan motor switch and turn the ignition switch to "ON" again.

If the fan motor does not stop, check for a shorted wire between the fan motor and switch.

If the fan motor stops, the fan motor switch is faulty.

#### Fan motor does not start

Before testing, check for a blown fan motor fuse.

Warm up the engine to operating temperature until the fan motor starts.

Disconnect the connector from the fan motor switch and ground the connector to the body ground.

Turn the ignition switch to "ON" and check the fan motor.

If the motor starts, check the connection at the fan motor switch terminal. If it is OK, the fan motor switch is faulty.

If the motor does not start, remove the lower radiator bolts (page 6-7) and swing the radiator forward.

Check for voltage between the fan motor switch connector terminals on the main wire harness side.

- Battery voltage: Faulty fan motor
- No battery voltage:
  - Open circuit or poor connection
  - Faulty ignition switch

### REMOVAL/INSTALLATION

Remove the lower radiator cover (page 6-7).

Drain the coolant (page 6-5).

Disconnect the switch connector and remove the fan motor switch.

Install a new O-ring onto the switch.

Install and tighten the fan motor switch to the specified torque.

**TORQUE: 17 N·m (1.7 kgf·m, 12 lbf·ft)**

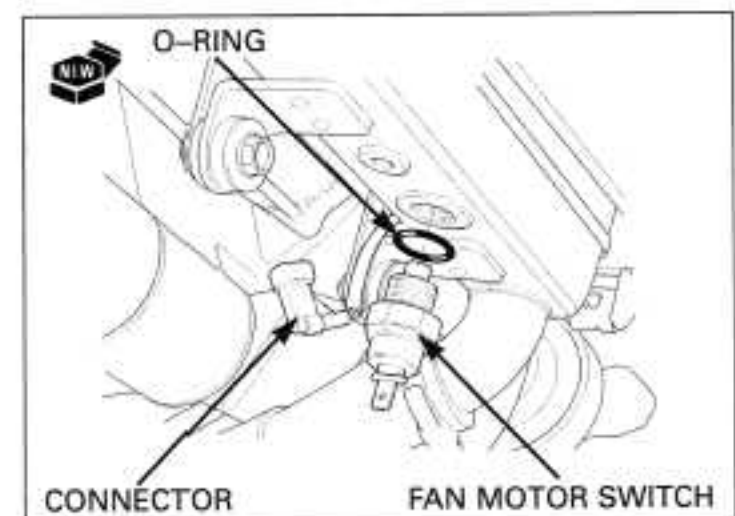
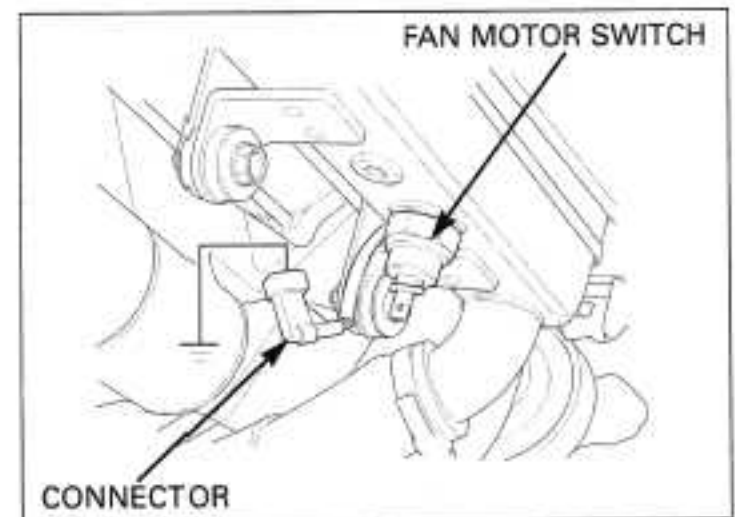
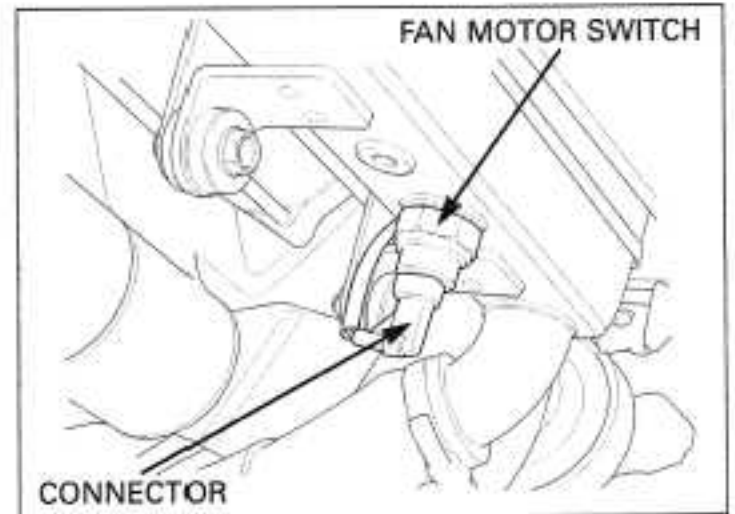

## COOLANT TEMPERATURE INDICATOR

Support the rear end of the fuel tank (page 3-4).

Disconnect the ECT/thermo sensor 3P connector from the sensor.

Ground the ECT/thermo sensor 3P connector Green/blue terminal with a jumper wire.

Turn the ignition switch to "ON" and check the coolant temperature indicator.  
Disconnect the ECT/thermo sensor wire connector from the ground immediately if the indicator comes on.

If the indicator comes on, check the ECT/thermo sensor unit (see next page).

If the indicator does not come on, check for voltage between the sensor wire connector and ground.

If voltage is measured, the indicator box is faulty.  
If there is no voltage, check for voltage between the Green/orange and Green/blue wire terminals.

If there is no voltage between the terminals, the indicator box unit is faulty.  
If voltage is measured, check the wire harness.

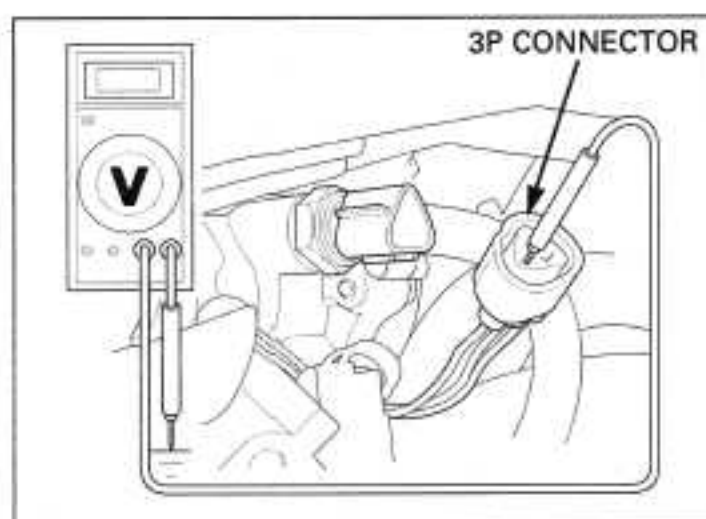
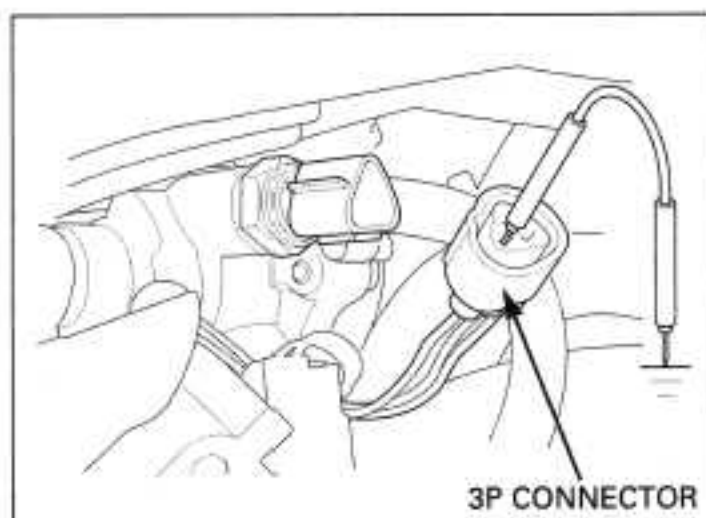
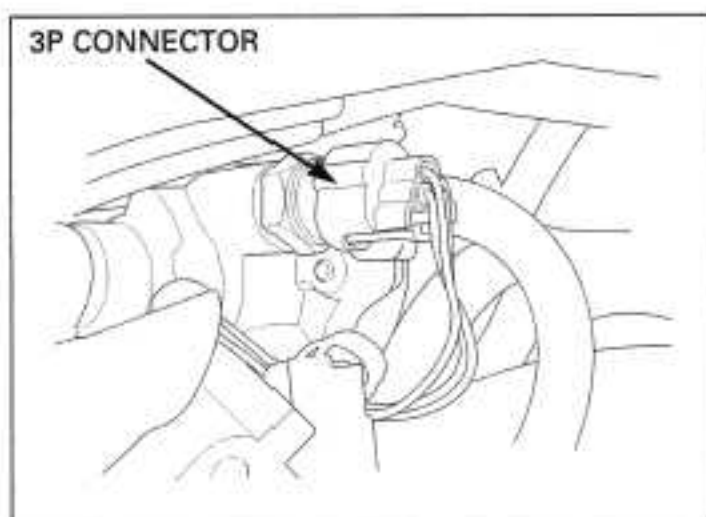

## ECT/THERMO SENSOR UNIT INSPECTION

Drain the coolant (page 6-5).  
Remove the air cleaner housing (page 5-57).

Disconnect the 3P connector from the ECT/thermo sensor and remove the sensor.

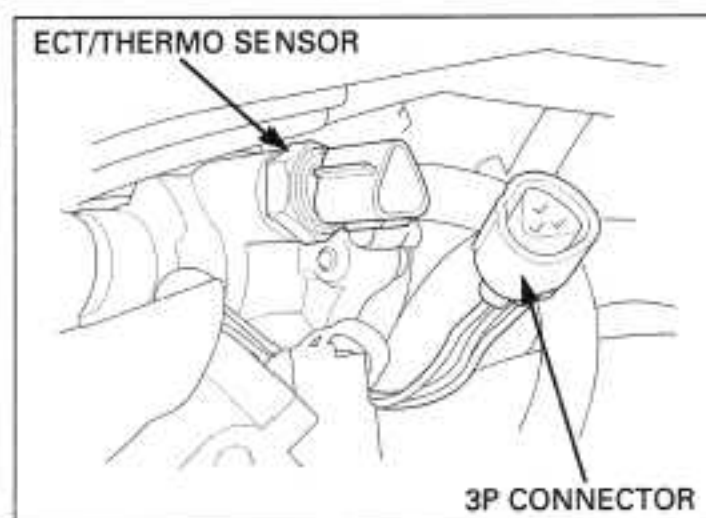

*Wear insulated gloves and adequate eye protection. Keep flammable materials away from the electric heating element. Do not let the thermostat or thermometer touch the pan, or you will get false readings.*

Suspend the ECT/thermo sensor in a pan of coolant (1:1 mixture) on an electric heating element and measure the resistance through the sensor as the coolant heats up.

- Soak the thermo sensor in coolant up to its threads with at least 40 mm (1.57 in) from the bottom of the pan to bottom of the sensor.
- Keep the temperature constant for 3 minutes before testing. A sudden change of temperature will result in an incorrect reading. Do not let the thermometer or thermo sensor touch the pan.

**STANDARD: 0.31 – 0.33 k $\Omega$  (80 °C/68 °F)  
0.13 – 0.14 k $\Omega$  (120 °C/248 °F)**

Replace the sensor if it is out of specification by more than 10% at any temperature listed.

*Always replace the sealing washer with a new one.*

Install and tighten the ECT/thermo sensor to the specified torque.

**TORQUE: 18 N·m (1.8 kgf·m, 13 lbf·ft)**

Connect the ECT/thermo sensor 3P connector.

Fill the system and bleed any air (page 6–5).  
Install the air cleaner housing (page 5–57).

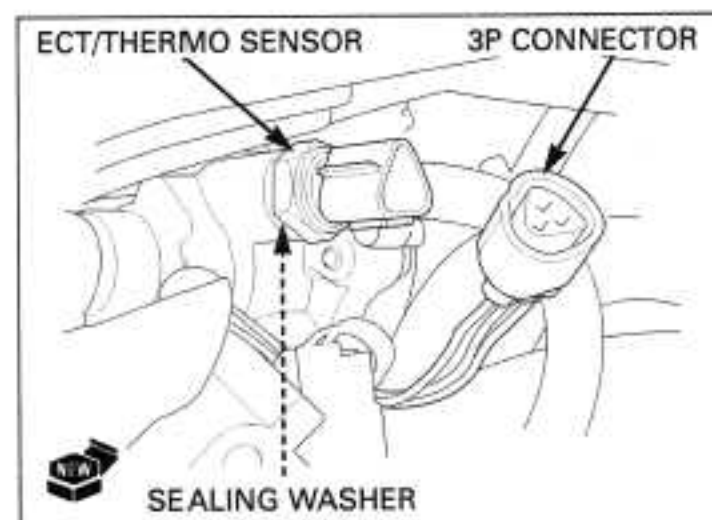
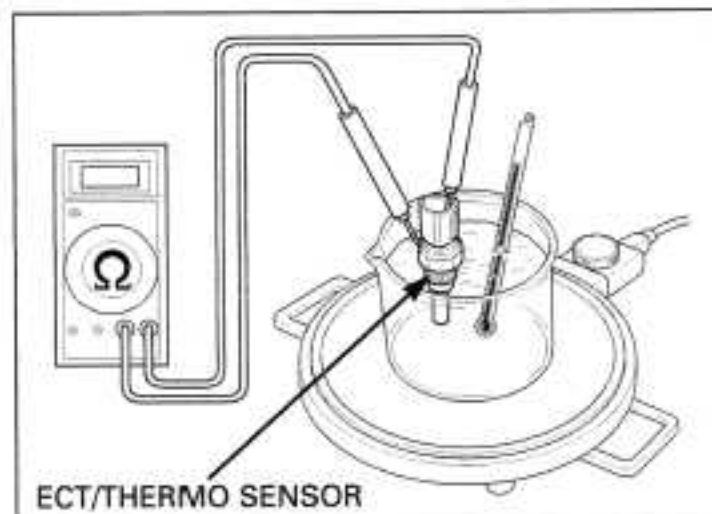

## **SIDE STAND SWITCH**

### **INSPECTION**

Remove the left rear crankcase cover (page 2–3).

Disconnect the side stand switch 2P green connector. Check for continuity at the switch side of the 2P green connector.

There should be continuity with the side stand retracted.  
There should be no continuity with the side stand down.

### **REMOVAL**

Remove the left rear crankcase cover (page 2–3).

Disconnect the side stand switch 2P green connector.

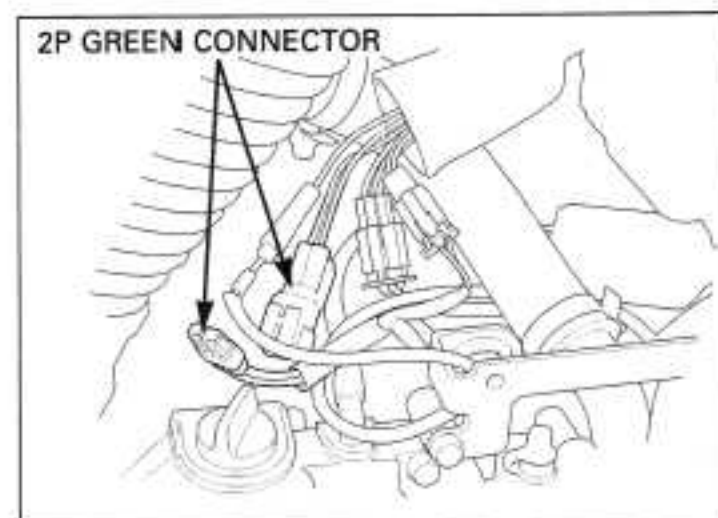
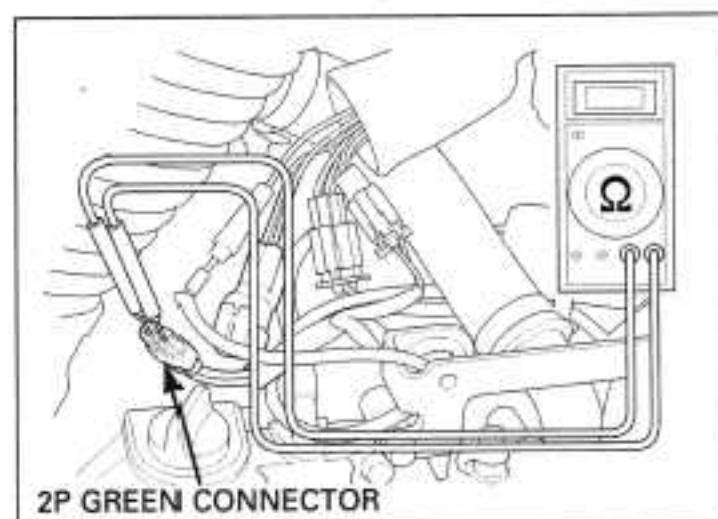



## LIGHTS/METERS/SWITCHES

Support the motorcycle securely.  
Remove the bolt, plate, washer and side stand switch from the side stand pivot.

### INSTALLATION

Install the side stand switch aligning the switch pin with the side stand hole.  
Install the washer and plate aligning the tab on the plate with the switch groove and the groove on the plate with the return spring holding pin.  
Install and tighten the new side stand switch bolt to the specified torque.

**TORQUE: 10 N·m (1.0 kgf·m, 7 lbf·ft)**

Install the removed parts in the reverse order of removal.

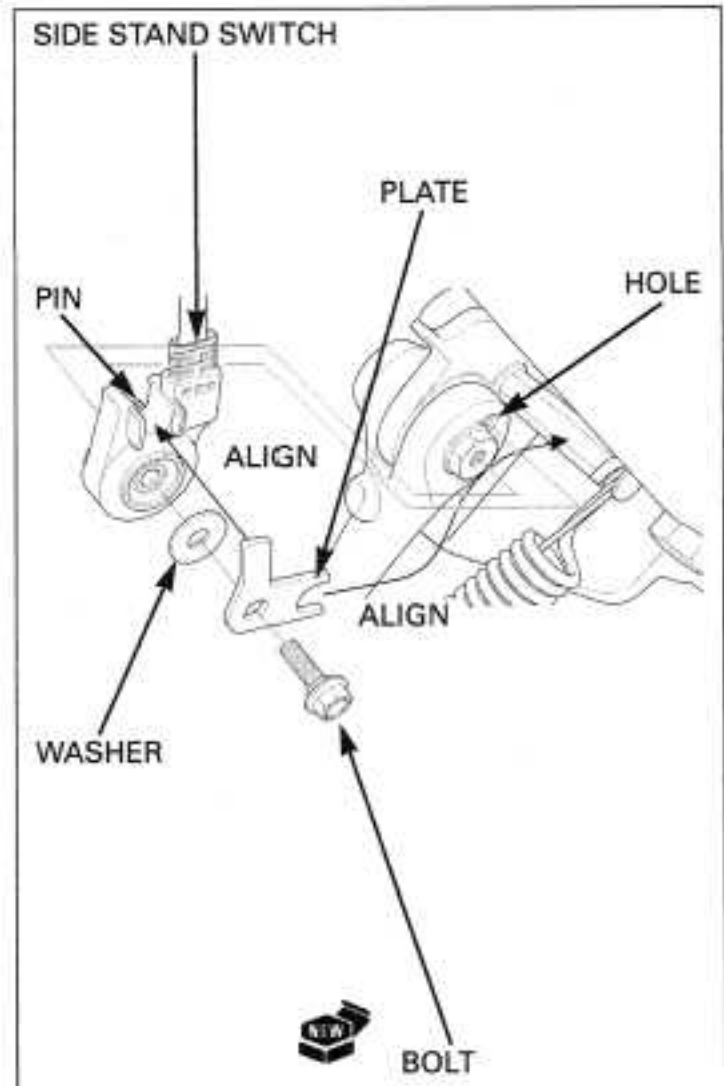

## OIL PRESSURE INDICATOR

### INSPECTION

**Indicator does not come on with the ignition switch turned to "ON"**  
Remove the rubber cap, and disconnect the oil pressure switch wire by removing the terminal screw.  
Ground the wire terminal to the engine with a jumper wire.

Turn the ignition switch to "ON" and check the oil pressure indicator.  
If the indicator comes on, replace the oil pressure switch.

If the indicator does not come on, check for an open circuit in the Blue/red wire.

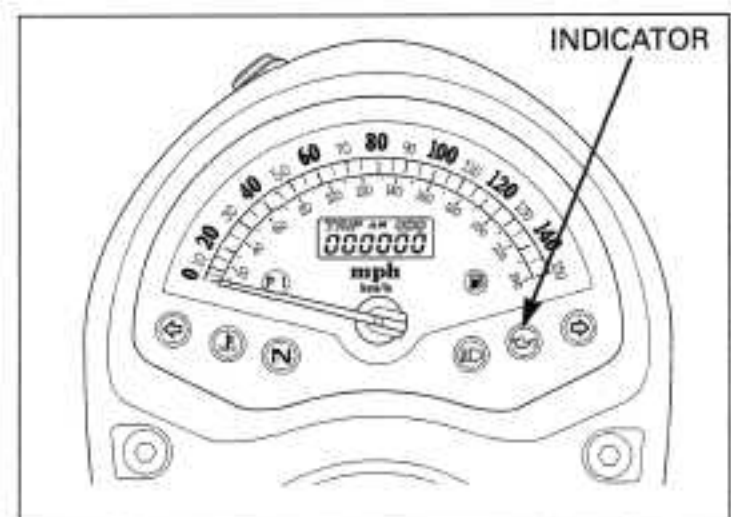
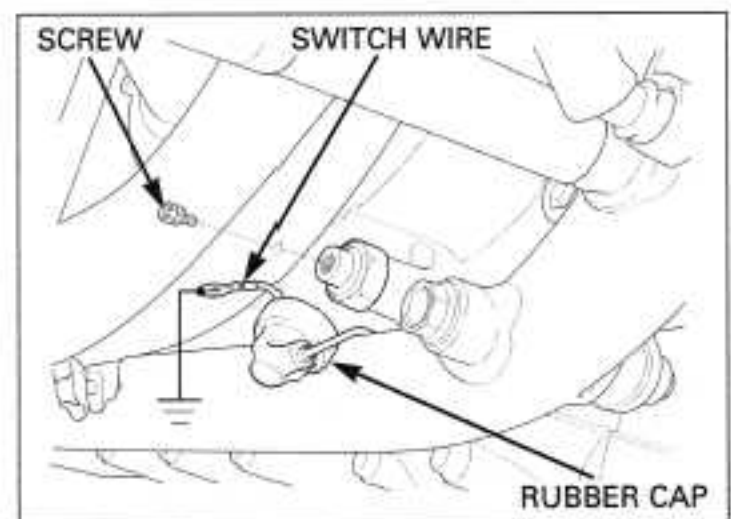



**Indicator stays on while the engine is running**

Remove the rubber cap, and disconnect the oil pressure switch wire by removing the terminal screw. Check for continuity, and check for a short circuit in the Blue/red wire.

If there is no continuity, check the oil pressure (page 4-3).

If the oil pressure is normal, replace the oil pressure switch.

**OIL PRESSURE SWITCH REMOVAL/INSTALLATION**

Remove the rubber cap, and disconnect the oil pressure switch wire by removing the terminal screw. Remove the oil pressure switch.

Apply sealant to the pressure switch threads and install it.

**TORQUE: 12 N·m (1.2 kgf·m, 9 lbf·ft)**

Connect the oil pressure switch wire and tighten the screw.

**TORQUE: 2 N·m (0.2 kgf·m, 1.4 lbf·ft)**

Cover the rubber cap to the oil pressure switch.

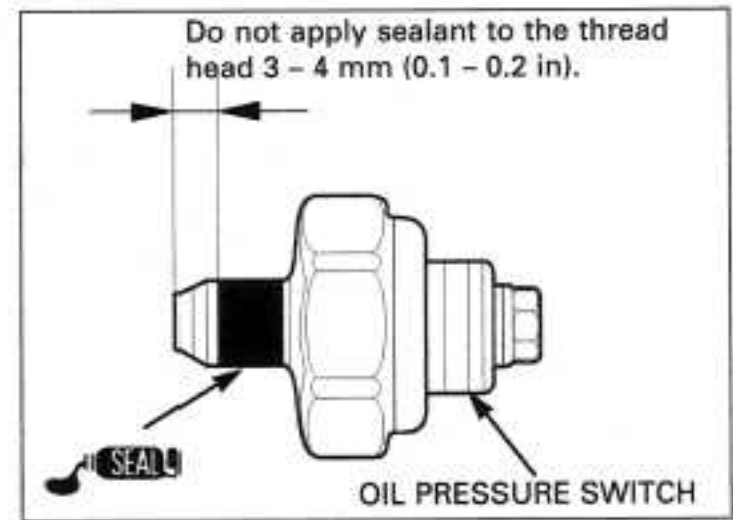
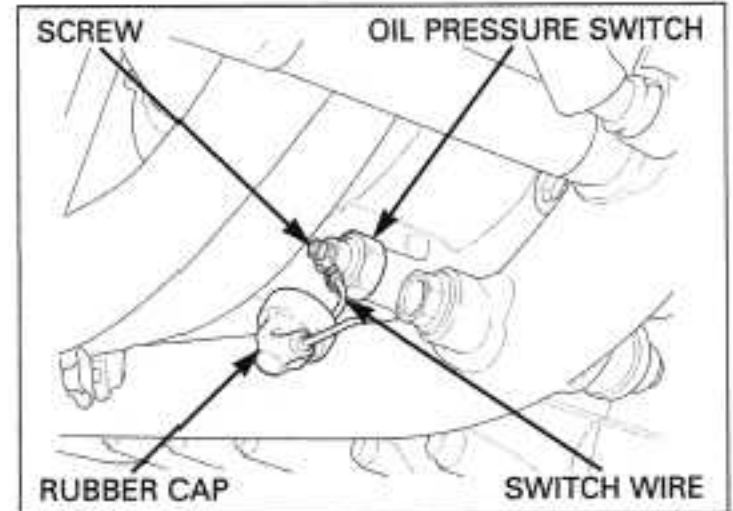

**HORN**

**INSPECTION**

Disconnect the wire connectors from the horn.

Connect a 12-V battery to the horn terminals. The horn is normal if it sounds when the 12-V battery is connected across the horn terminals.

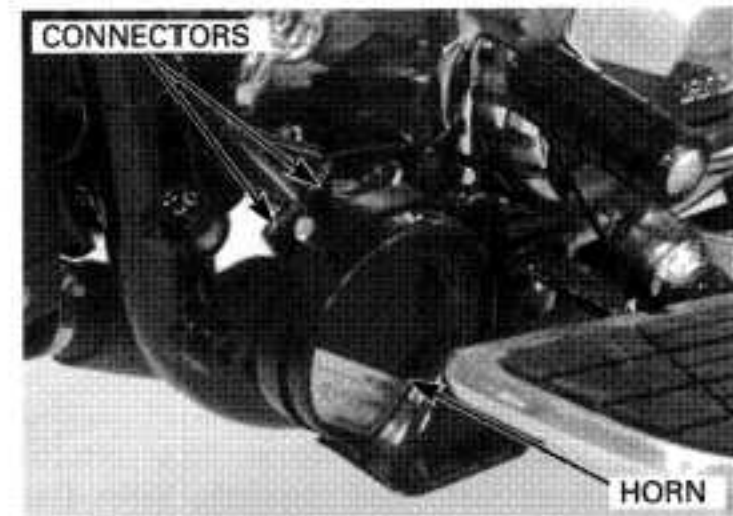

**REMOVAL/INSTALLATION**

Remove the left step holder (page 16-10).

Remove the bolt and horn.

Installation is in the reverse order of removal.

**TORQUE: 21 N·m (2.1 kgf·m, 15 lbf·ft)**

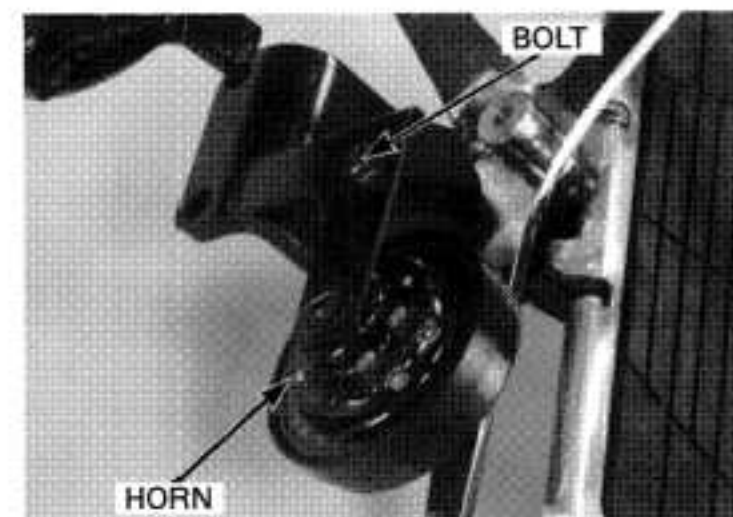

## TURN SIGNAL RELAY

### INSPECTION

**The turn signal does not blink**

Remove the right side cover (page 2-2).

Remove the turn signal relay from the battery case and disconnect the 3P black connector.

Short the Gray and White/green wire terminals of the relay connector with a jumper wire.  
Check the turn signal with the ignition switch turned to "ON".

- Light does not come on: Open circuit in the wire harness
- Light comes on:  
Check for continuity between the Green wire terminal and ground.
  - No continuity: Open circuit in the wire harness
  - Continuity: Faulty turn signal relay or poor connection of the connector

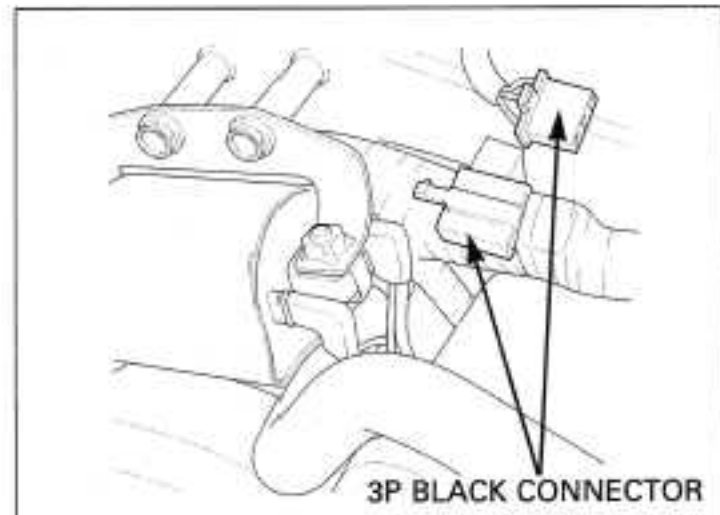
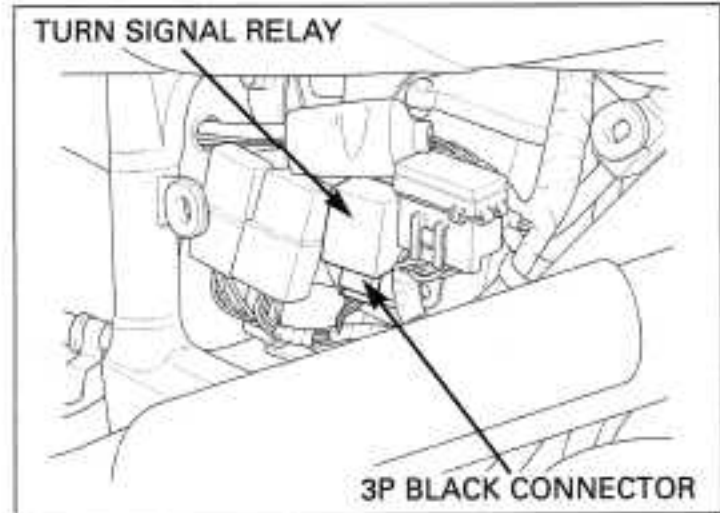

## FUEL RESERVE SENSOR

### INSPECTION

If the fuel reserve indicator does not indicate properly, check the following.

Open and support the rear end of the fuel tank (page 3-4).

Disconnect the fuel pump 3P black connector.  
Jump the Brown/black and Green wire terminals of the wire harness side using a jumper wire.

Turn the ignition switch to "ON" and make sure the fuel reserve indicator comes on.

If the fuel reserve indicator comes on, replace the fuel pump assembly.  
If the fuel reserve indicator does not come on, check for open or short circuit in wire harness.

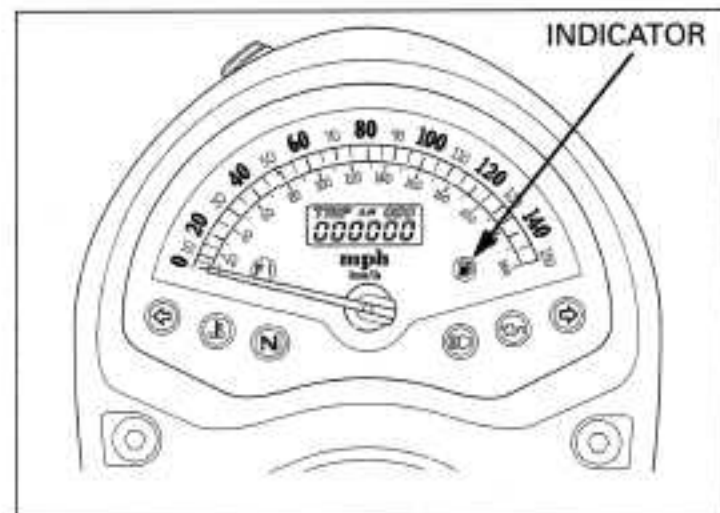

## TURN SIGNAL RELAY

### INSPECTION

**The turn signal does not blink**  
Remove the right side cover (page 2-2).

Remove the turn signal relay from the battery case and disconnect the 3P black connector.

Short the Gray and White/green wire terminals of the relay connector with a jumper wire.  
Check the turn signal with the ignition switch turned to "ON".

- Light does not come on: Open circuit in the wire harness
- Light comes on:
  - Check for continuity between the Green wire terminal and ground.
    - No continuity: Open circuit in the wire harness
    - Continuity: Faulty turn signal relay or poor connection of the connector

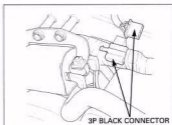
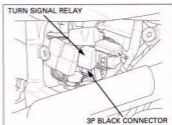

## FUEL RESERVE SENSOR

### INSPECTION

If the fuel reserve indicator does not indicate properly, check the following.

Open and support the rear end of the fuel tank (page 3-4).

Disconnect the fuel pump 3P black connector.  
Jump the Brown/black and Green wire terminals of the wire harness side using a jumper wire.

Turn the ignition switch to "ON" and make sure the fuel reserve indicator comes on.

If the fuel reserve indicator comes on, replace the fuel pump assembly.  
If the fuel reserve indicator does not come on, check for open or short circuit in wire harness.

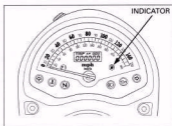

**FUEL TANK HOLDS 5.28 GALLONS  
4.48 GAL. NORMAL (0.8 GAL. RESERVE)  
RESERVE IS ABOUT 25 MILES,  
@ 35 MILES/GALLON**

# 20. WIRING DIAGRAM

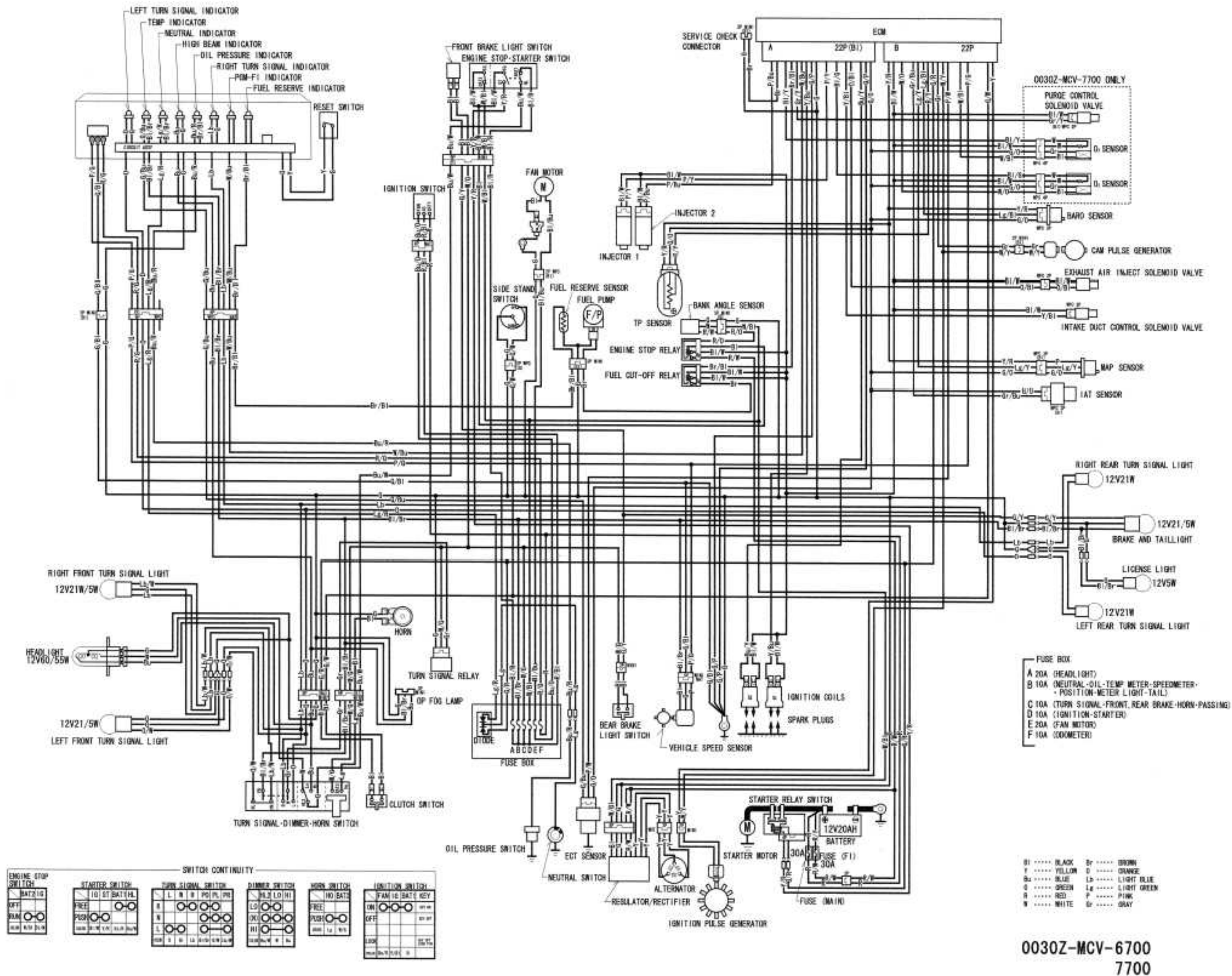



# 21. TROUBLESHOOTING

ENGINE DOES NOT START OR IS HARD TO START

21-1

POOR PERFORMANCE AT HIGH SPEED

21-4

ENGINE LACKS POWER

21-2

POOR HANDLING

21-4

POOR PERFORMANCE AT LOW AND IDLE SPEED

21-3

## ENGINE DOES NOT START OR IS HARD TO START

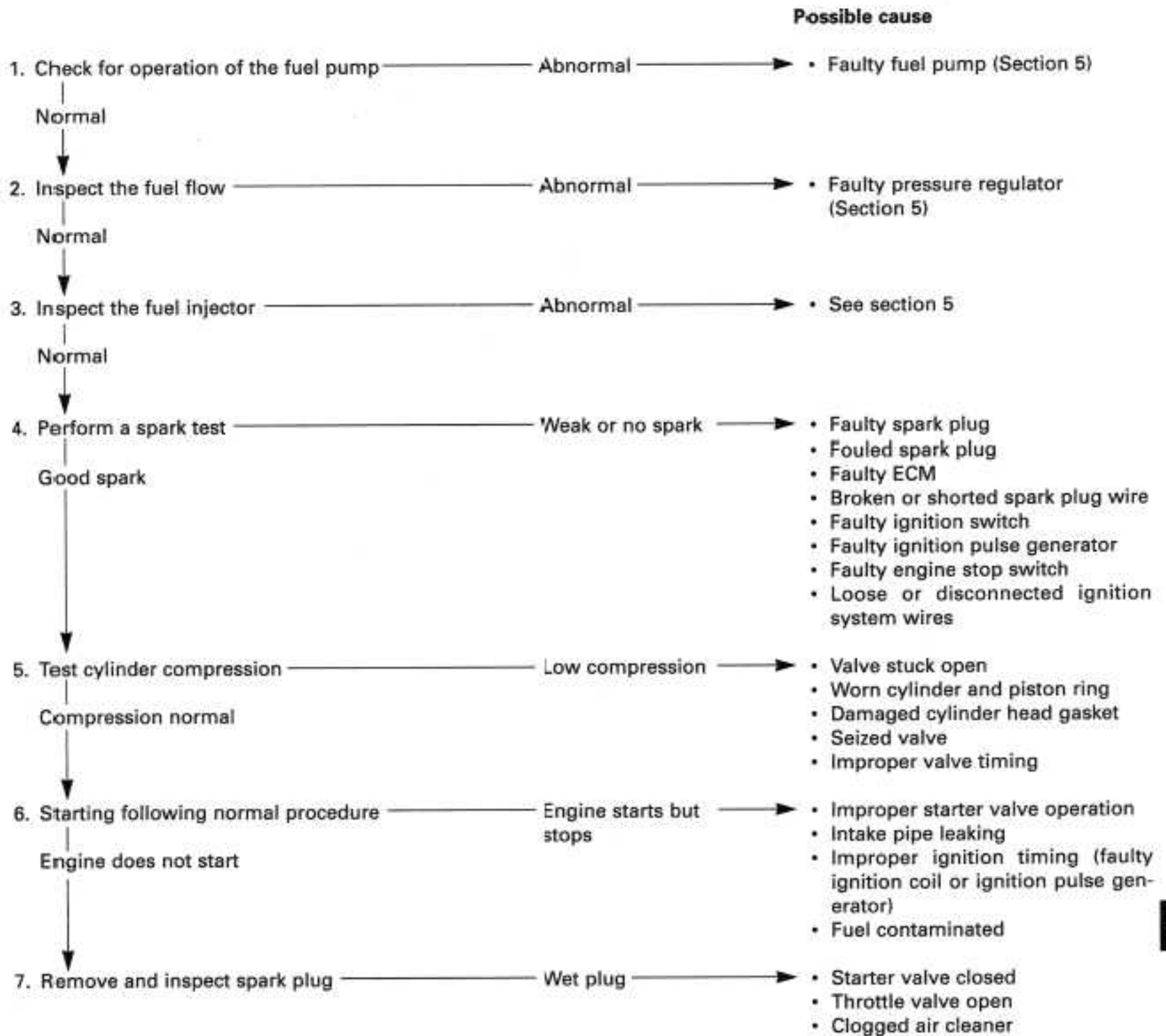

**ENGINE LACKS POWER**



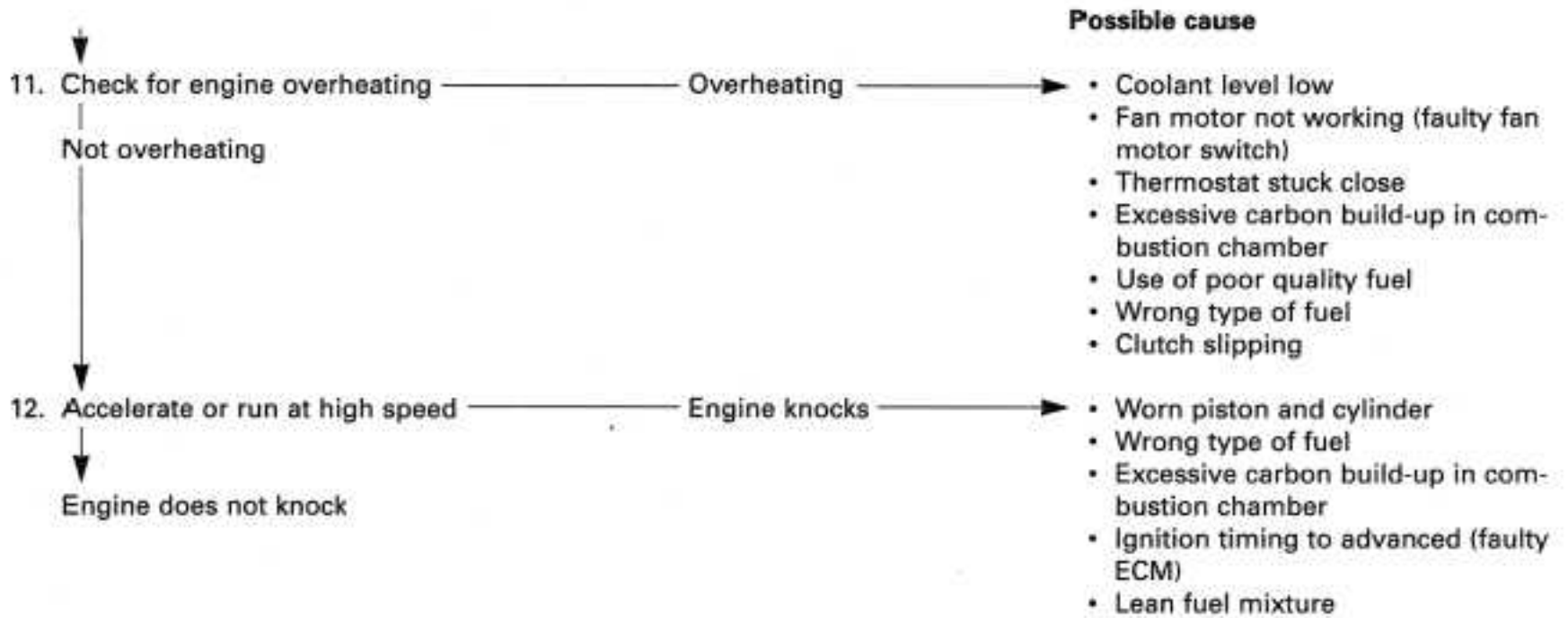

**POOR PERFORMANCE AT LOW AND IDLE SPEED**

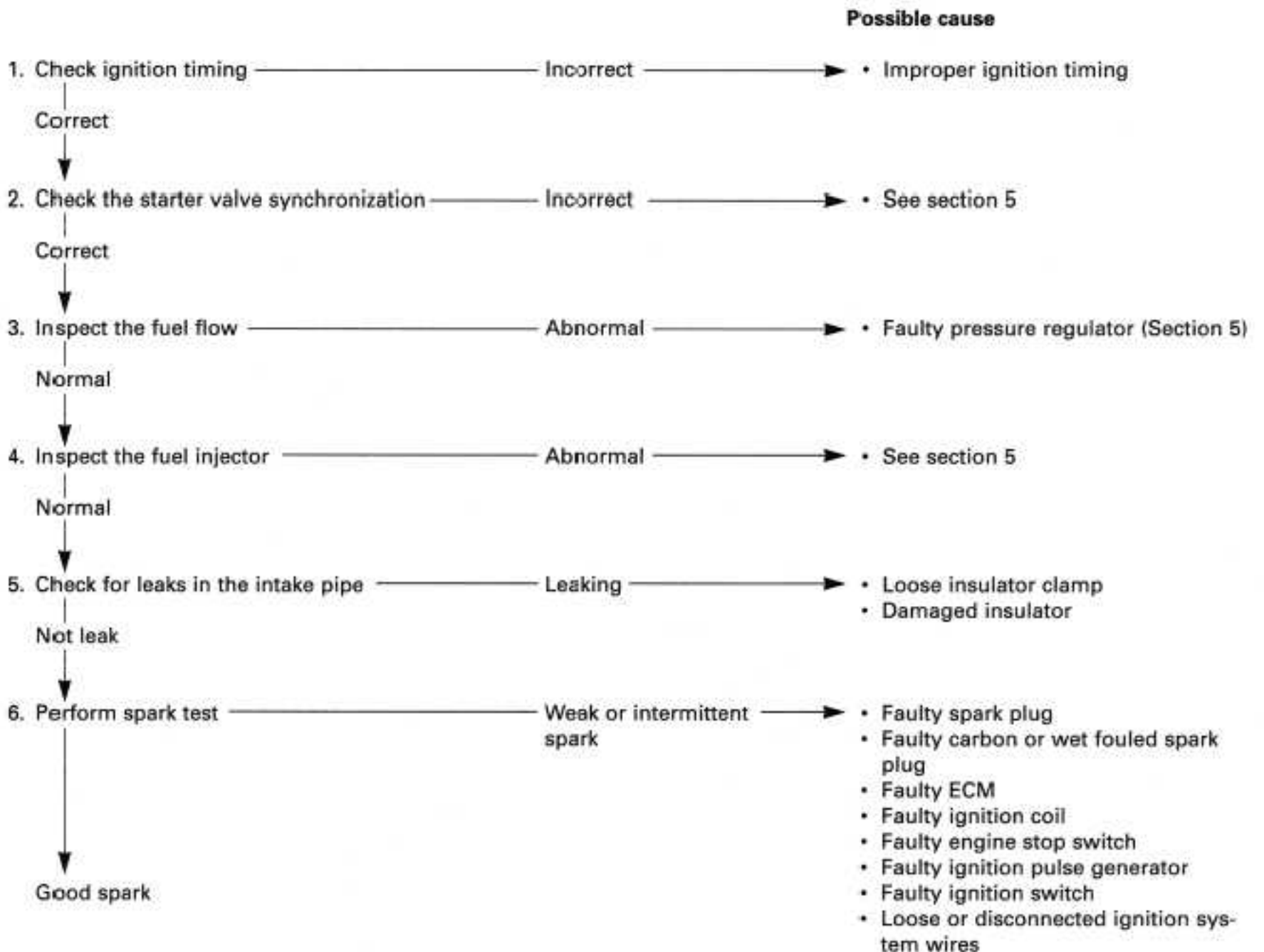

## TROUBLESHOOTING

---

### POOR PERFORMANCE AT HIGH SPEED

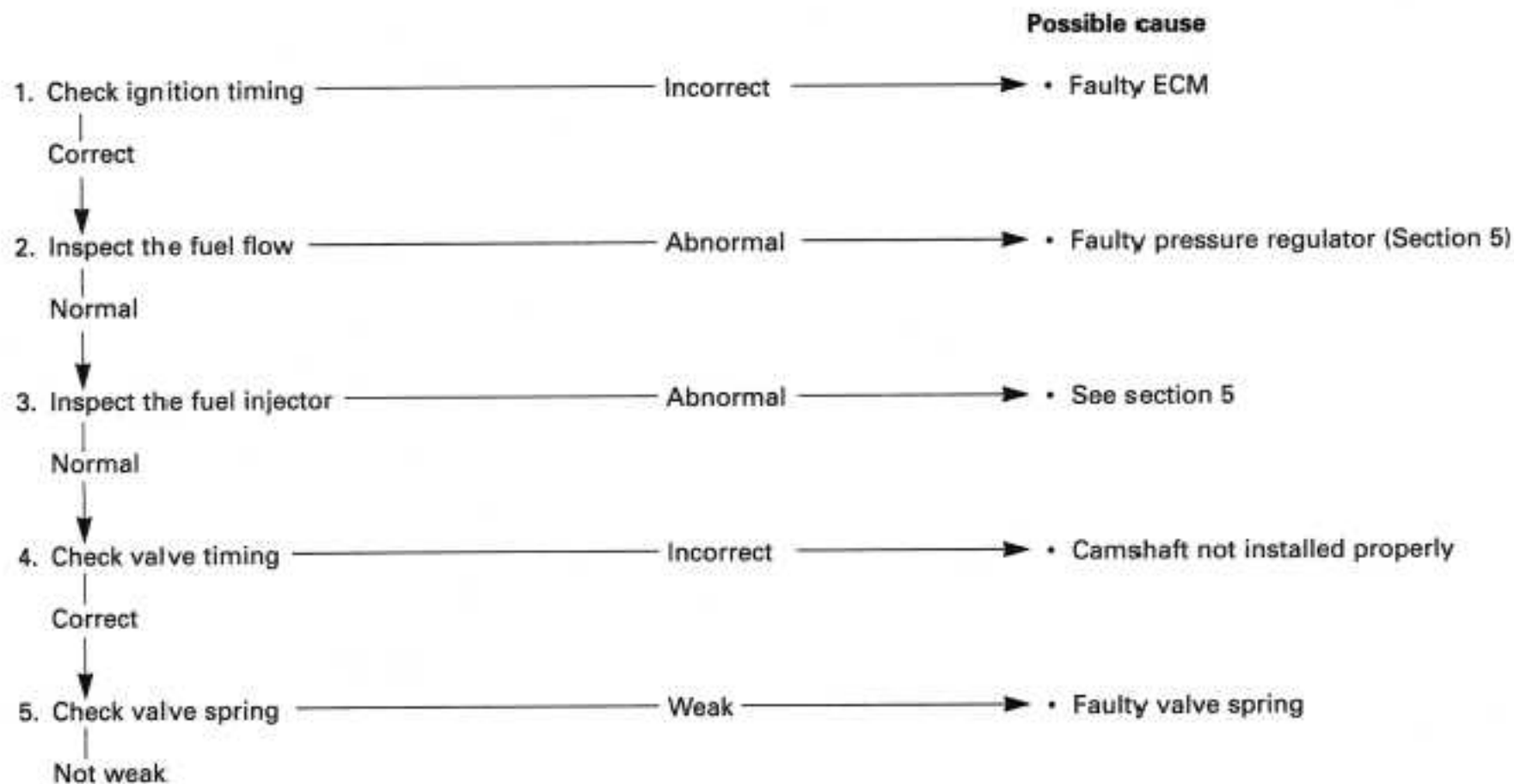

### POOR HANDLING

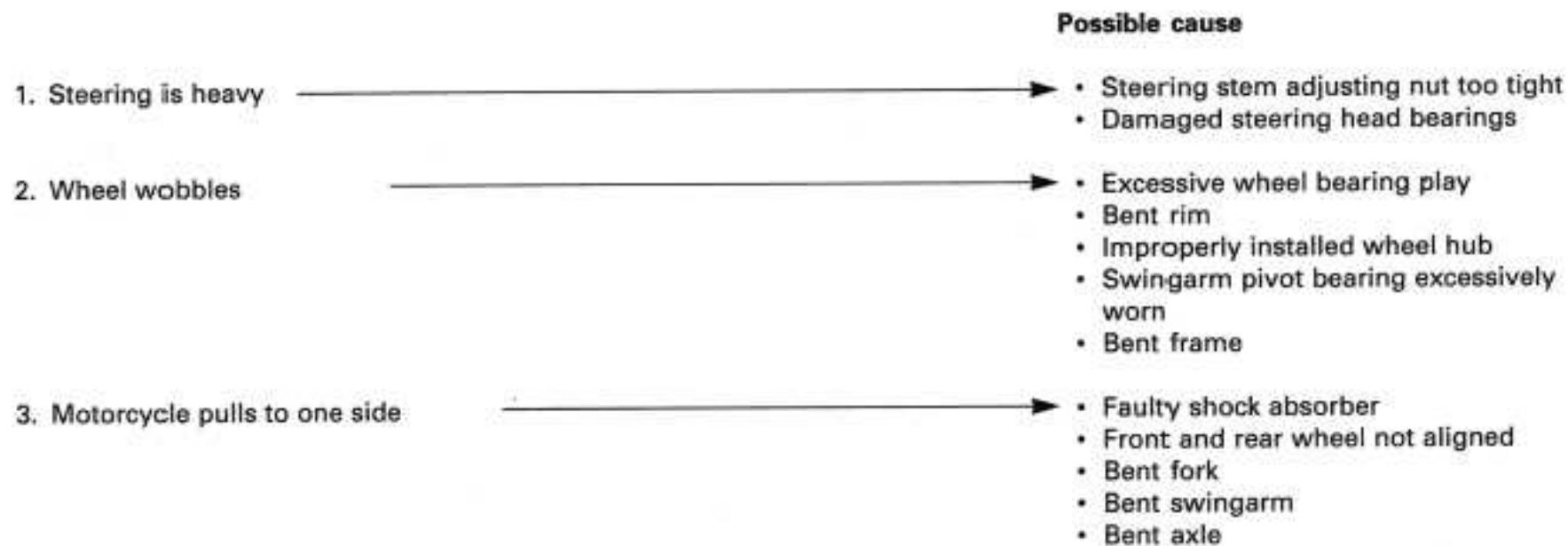



# 22. INDEX

AIR CLEANER	3-5	EXHAUST SYSTEM	2-3
AIR CLEANER HOUSING	5-51	FAN MOTOR SWITCH	19-15
AIR SCREW SYNCHRONIZATION	5-66	FINAL DRIVE GEAR	12-5
ALTERNATOR	16-9	FINAL DRIVE INSTALLATION	12-18
BALANCER WEIGHT	18-18	FINAL DRIVE REMOVAL	12-3
BANK ANGLE SENSOR	5-71	FINAL DRIVE OIL	3-17
BARO/MAP SENSOR	5-67	FLYWHEEL/STARTER CLUTCH	18-12
BATTERY	16-4	FORK	13-14
BATTERY CASE	16-7	FRONT BRAKE LIGHT SWITCH	19-12
BRAKE FLUID	3-18	FRONT CALIPER	15-17
BRAKE FLUID REPLACEMENT/AIR BLEEDING	15-4	FRONT MASTER CYLINDER	15-12
BRAKE PAD/DISC	15-10	FRONT WHEEL	13-8
BRAKE PAD WEAR	3-19	FUEL CUT-OFF RELAY	5-50
BRAKE PEDAL	15-30	FUEL LINE	3-4
BRAKE LIGHT SWITCH	3-20	FUEL LINE INSPECTION	5-46
BRAKE SYSTEM	3-19	FUEL PUMP	5-48
CABLE & HARNESS ROUTING	1-23	FUEL RESERVE SENSOR	19-20
CAM PULSE GENERATOR	5-69	FUEL TANK	5-50
CAMSHAFT INSTALLATION	8-20	GEARSHIFT LINKAGE	10-28
CAMSHAFT REMOVAL	8-4	HANDLEBAR	13-3
CHARGING SYSTEM INSPECTION	16-6	HANDLEBAR SWITCH	19-14
CLUTCH	10-15	HEADLIGHT	19-4
CLUTCH FLUID	3-21	HEADLIGHT AIM	3-20
CLUTCH FLUID REPLACEMENT/AIR BLEEDING	10-4	HORN	19-19
CLUTCH MASTER CYLINDER	10-6	IAT SENSOR	5-68
CLUTCH SLAVE CYLINDER	10-11	IGNITION COIL	17-5
CLUTCH SWITCH	19-12	IGNITION SWITCH	19-13
CLUTCH SYSTEM	3-21	IGNITION SYSTEM INSPECTION	17-3
COOLANT REPLACEMENT	6-4	IGNITION TIMING	17-5
COOLANT TEMPERATURE INDICATOR	19-16	INJECTOR	5-60
COOLING SYSTEM	3-15	INTAKE DUCT CONTROL SOLENOID VALVE	5-73
CRANKCASE ASSEMBLY	11-17	LEFT CRANKCASE REAR COVER	2-2
CRANKCASE SEPARATION	11-4	LICENSE LIGHT	19-6
CRANKCASE BEARING REPLACEMENT	11-25	LUBRICATION & SEAL POINTS	1-19
CRANKCASE BREATHER	3-6	MAINTENANCE SCHEDULE	3-3
CRANKSHAFT/CONNECTING ROD	11-6	MODEL IDENTIFICATION	1-1
CYLINDER COMPRESSION	8-3	NEUTRAL SWITCH	19-11
CYLINDER INSTALLATION	9-10	NUTS, BOLTS, FASTENERS	3-23
CYLINDER REMOVAL	9-3	O <sub>2</sub> SENSOR (CALIFORNIA TYPE ONLY)	5-78
CYLINDER HEAD ASSEMBLY	8-17	OIL PRESSURE CHECK	4-3
CYLINDER HEAD DISASSEMBLY	8-10	OIL PRESSURE INDICATOR	19-18
CYLINDER HEAD INSTALLATION	8-19	OIL PUMP & OIL STRAINER	4-3
CYLINDER HEAD REMOVAL	8-3	OUTPUT SHAFT	11-19
CYLINDER HEAD COVER INSTALLATION	8-25	PAIR CHECK REED VALVE	5-76
CYLINDER HEAD REMOVAL	8-3	PAIR SOLENOID VALVE	5-75
ECM (Engine Control Module)	5-73	PCV (Proportional Control Valve)	15-31
ECT SENSOR	5-68	PGM-FI SELF-DIAGNOSIS MALFUNCTION INDICATOR FAILURE CODES	5-10
EMISSION CONTROL INFORMATION LABELS (CALIFORNIA TYPE ONLY)	1-36	PGM-FI (Programmed Fuel Injection) SYSTEM	5-6
EMISSION CONTROL SYSTEMS	1-33	PISTON INSTALLATION	9-9
ENGINE DOES NOT START OR IS HARD TO START	21-1	PISTON REMOVAL	9-5
ENGINE IDLE SPEED	3-15	PISTON RING INSTALLATION	9-8
ENGINE LACKS POWER	21-2	POOR HANDLING	21-4
ENGINE OIL/OIL FILTER	3-12	POOR PERFORMANCE AT HIGH SPEED	21-4
ENGINE INSTALLATION	7-7	POOR PERFORMANCE AT LOW AND IDLE SPEED	21-3
ENGINE REMOVAL	7-2	PRIMARY DRIVE GEAR	10-24
ENGINE STOP RELAY	5-72	PRIMARY DRIVEN GEAR	10-25
EVAP PURGE CONTROL VALVE (CALIFORNIA TYPE ONLY)	5-77	PRIMARY SHAFT	11-5
EVAPORATIVE EMISSION CONTROL SYSTEM (CALIFORNIA TYPE ONLY)	3-17	RADIATOR COOLANT	3-15
		RADIATOR/COOLING FAN	6-6
		RADIATOR RESERVE TANK	6-9

## INDEX

---

REAR BRAKE LIGHT SWITCH	19-12	TROUBLESHOOTING	
REAR CALIPER	15-27	(CYLINDER/PISTON)	9-2
REAR FENDER	2-3	(ELECTRIC STARTER/STARTER CLUTCH)	18-2
REAR MASTER CYLINDER	15-21	(FINAL DRIVE)	12-2
REAR WHEEL	14-3	(FRONT WHEEL/SUSPENSION/STEERING)	13-2
REGULATOR/RECTIFIER	16-8	(FUEL SYSTEM)	5-3
RIGHT CRANKCASE COVER	10-13	(HYDRAULIC BRAKE)	15-3
SEAT	2-2	(IGNITION SYSTEM)	17-2
SECONDARY AIR SUPPLY SYSTEM	3-16	(LIGHTS/METERS/SWITCHES)	19-3
SERVICE INFORMATION		(LUBRICATION SYSTEM)	4-2
(CHARGING SYSTEM/ALTERNATOR)	16-1	(REAR WHEEL/SUSPENSION)	14-2
(CLUTCH/GEARSHIFT LINKAGE)	10-2	TURN SIGNAL	19-5
(COOLING SYSTEM)	6-1	TURN SIGNAL RELAY	19-20
(CRANKSHAFT/TRANSMISSION)	11-1	VALVE CLEARANCE	3-8
(CYLINDER HEAD/VALVES)	8-1	VALVE GUIDE REPLACEMENT	8-13
(CYLINDER/PISTON)	9-1	VALVE SEAT INSPECTION/REFACING	8-14
(ELECTRIC STARTER/STARTER CLUTCH)	18-1	VEHICLE SPEED SENSOR	19-9
(ENGINE REMOVAL/INSTALLATION)	7-1	WATER PUMP	6-12
(FINAL DRIVE)	12-1	WHEELS/TIRES	3-23
(FRAME/BODY PANELS/EXHAUST SYSTEM)	2-1	WIRING DIAGRAM	20-1
(FRONT WHEEL/SUSPENSION/STEERING)	13-1		
(FUEL SYSTEM)	5-1		
(HYDRAULIC BRAKE)	15-2		
(IGNITION SYSTEM)	17-1		
(LIGHTS/METERS/SWITCHES)	19-1		
(LUBRICATION SYSTEM)	4-1		
(MAINTENANCE)	3-1		
(REAR WHEEL/SUSPENSION)	14-1		
SERVICE RULES	1-1		
SHOCK ABSORBER	14-11		
SIDE COVER	2-2		
SIDE STAND	3-21		
SIDE STAND SWITCH	19-17		
SPARK PLUG	3-6		
SPECIFICATIONS	1-3		
SPEEDOMETER/INDICATOR BOX	19-7		
STARTER MOTOR	18-4		
STARTER RELAY SWITCH	18-10		
STARTER VALVE	5-64		
STEERING HEAD BEARINGS	3-23		
STEERING STEM	13-33		
SUSPENSION	3-22		
SWINGARM	14-12		
SYSTEM DIAGRAM	5-5		
SYSTEM LOCATION	5-4		
SYSTEM TESTING	6-3		
TAIL/BRAKE LIGHT	19-6		
THERMOSTAT	6-9		
THROTTLE BODY	5-52		
THROTTLE OPERATION	3-4		
TOOLS	1-17		
TORQUE VALUES	1-12		
TP SENSOR	5-69		
TRANSMISSION	11-11		
TROUBLESHOOTING			
(CHARGING SYSTEM/ALTERNATOR)	16-2		
(CLUTCH/GEARSHIFT LINKAGE)	10-3		
(COOLING SYSTEM)	6-2		
(CRANKSHAFT/TRANSMISSION)	11-3		
(CYLINDER HEAD/VALVES)	8-2		

# A Few Words About Safety

## Service information

The service and repair information contained in this manual is intended for use by qualified, professional technicians. Attempting service or repairs without the proper training, tools, and equipment could cause injury to you or others. It could also damage the vehicle or create an unsafe condition.

This manual describes the proper methods and procedures for performing service, maintenance, and repairs. Some procedures require the use of specially designed tools and dedicated equipment. Any person who intends to use a replacement part, service procedure or a tool that is not recommended by Honda, must determine the risks to their personal safety and the safe operation of the vehicle.

If you need to replace a part, use genuine Honda parts with the correct part number or an equivalent part. We strongly recommended that you do not use replacement parts of inferior quality.

## For Your Customer's Safety

Proper service and maintenance are essential to the customer's safety and the reliability of the vehicle. Any error or oversight while servicing a vehicle can result in faulty operation, damage to the vehicle, or injury to others.

### **⚠ WARNING**

Improper service or repairs can create an unsafe condition that can cause your customer or others to be seriously hurt or killed.

Follow the procedures and precautions in this manual and other service materials carefully.

## For Your Safety

Because this manual is intended for the professional service technician, we do not provide warnings about many basic shop safety practices (e. g., Hot parts - wear gloves). If you have not received shop safety training or do not feel confident about your knowledge of safe servicing practice, we recommended that you do not attempt to perform the procedures described in this manual.

Some of the most important general service safety precautions are given below. However, we cannot warn you of every conceivable hazard that can arise in performing service and repair procedures. Only you can decide whether or not you should perform a given task.

### **⚠ WARNING**

Failure to properly follow instructions and precautions can cause you to be seriously hurt or killed.

Follow the procedures and precautions in this manual carefully.

## Important Safety Precautions

Make sure you have a clear understanding of all basic shop safety practices and that you are wearing appropriate clothing and using safety equipment. When performing any service task, be especially careful of the following:

- Read all of the instructions before you begin, and make sure you have the tools, the replacement or repair parts, and the skills required to perform the tasks safely and completely.
- Protect your eyes by using proper safety glasses, goggles or face shields any time you hammer, drill, grind, pry or work around pressurized air or liquids, and springs or other stored-energy components. If there is any doubt, put on eye protection.



- Use other protective wear when necessary, for example gloves or safety shoes. Handling hot or sharp parts can cause severe burns or cuts. Before you grab something that looks like it can hurt you, stop and put on gloves.
- Protect yourself and others whenever you have the vehicle up in the air. Any time you lift the vehicle, either with a hoist or a jack, make sure that it is always securely supported. Use jack stands.

Make sure the engine is off before you begin any servicing procedures, unless the instruction tells you to do otherwise. This will help eliminate several potential hazards:

- Injury from moving parts. If the instruction tells you to run the engine, be sure your hands, fingers and clothing are out of the way.



Gasoline vapors and hydrogen gases from batteries are explosive. To reduce the possibility of a fire or explosion, be careful when working around gasoline or batteries.

- Use only a nonflammable solvent, not gasoline, to clean parts.
- Never drain or store gasoline in an open container.
- Keep all cigarettes sparks and flames away from the battery and all fuel-related parts.

Your safety, and the safety of others, is very important. To help you make informed decisions we have provided safety messages and other information throughout this manual. Of course, it is not practical or possible to warn you about all the hazards associated with servicing this vehicle. You must use your own good judgment.

You will find important safety information in a variety of forms including:

- Safety Labels - on the vehicle
- Safety Messages preceded by a safety alert symbol  and one of three signal words, DANGER, WARNING, or CAUTION. These signal words mean:

<b> DANGER</b>	You WILL be KILLED or SERIOUSLY HURT if you don't follow instructions.
<b> WARNING</b>	You CAN be KILLED or SERIOUSLY HURT if you don't follow instructions.
<b> CAUTION</b>	You CAN be HURT if you don't follow instructions.











- Instructions - on how to service this vehicle correctly and safely.

As you read this manual, you will find information that is preceded by a **NOTICE** symbol. The purpose of this message is to help prevent damage to your vehicle, other property, or the environment.

**ALL INFORMATION, ILLUSTRATIONS, DIRECTIONS AND SPECIFICATIONS INCLUDED IN THIS PUBLICATION ARE BASED ON THE LATEST PRODUCT INFORMATION AVAILABLE AT THE TIME OF APPROVAL FOR PRINTING. HONDA MOTOR CO., LTD. RESERVES THE RIGHT TO MAKE CHANGES AT ANY TIME WITHOUT NOTICE AND WITHOUT INCURRING ANY OBLIGATION WHATSOEVER. NO PART OF THIS PUBLICATION MAY BE REPRODUCED WITHOUT WRITTEN PERMISSION. THIS MANUAL IS WRITTEN FOR PERSONS WHO HAVE ACQUIRED BASIC KNOWLEDGE OF MAINTENANCE ON HONDA MOTORCYCLES, MOTOR SCOOTERS OR ATVS.**

## SYMBOLS

The symbols used throughout this manual show specific service procedures. If supplementary information is required pertaining to these symbols, it would be explained specifically in the text without the use of the symbols.

	Replace the part(s) with new one(s) before assembly.
	Use recommended engine oil, unless otherwise specified.
	Use molybdenum oil solution (mixture of the engine oil and molybdenum grease in a ratio of 1 : 1).
	Use multi-purpose grease (lithium based multi-purpose grease NLGI #2 or equivalent).
	Use molybdenum disulfide grease (containing more than 3% molybdenum disulfide, NLGI #2 or equivalent). Example: Molykote® BR-2 plus manufactured by Dow Corning U.S.A. Multi-purpose M-2 manufactured by Mitsubishi Oil, Japan
	Use molybdenum disulfide paste (containing more than 40% molybdenum disulfide, NLGI #2 or equivalent). Example: Molykote® G-n Paste manufactured by Dow Corning U.S.A. Honda Moly 60 (U.S.A. only) Rocol ASP manufactured by Rocol Limited, U.K. Rocol Paste manufactured by Sumico Lubricant, Japan
	Use silicone grease.
	Apply a locking agent. Use a medium strength locking agent unless otherwise specified.
	Apply sealant.
	Use DOT 4 brake fluid. Use the recommended brake fluid unless otherwise specified.
	Use fork or suspension fluid.